

---

## Central Valley Regional Water Quality Control Board

16 July 2020

Joseph Camarena, Jr.  
Sugar Pine Christian Camps  
48478 Mill Canyon Road  
Oakhurst, California 93644

**CERTIFIED MAIL**  
**7018 1830 0001 2775 4136**

**NOTICE OF APPLICABILITY (NOA); STATE WATER RESOURCES CONTROL BOARD ORDER WQ 2014-0153-DWQ; GENERAL WASTE DISCHARGE REQUIREMENTS FOR SMALL DOMESTIC WASTEWATER TREATMENT SYSTEMS; SUGAR PINE CHRISTIAN CAMPS; CAMP SUGAR PINE WASTEWATER TREATMENT SYSTEM; MADERA COUNTY**

On 27 September 2019, Central Valley Regional Water Quality Control Board (Central Valley Water Board) staff received a Report of Waste Discharge (RWD) prepared by QK, Inc., signed and stamped by Garth A. Pecchenino (RCE 52678) on behalf of Sugar Pine Christian Camps (Discharger) for its Camp Sugar Pine Wastewater Treatment System (Facility). The RWD included a completed and signed Form 200 and a technical report. Based on the information provided, the Facility treats and disposes of less than 100,000 gallons per day (gpd) of domestic wastewater and is eligible for coverage under State Water Resources Control Board (State Water Board) Water Quality Order 2014-0153-DWQ *General Waste Discharge Requirements for Small Domestic Wastewater Treatment Systems* (General Order). This letter serves as formal notice that the General Order is applicable to your system and the wastewater discharge described below upon the rescission of Waste Discharge Requirements (WDRs) Order 87-031. Your Facility's coverage under the General Order is hereby assigned **enrollee number 2014-0153-DWQ-R5340**.

You should familiarize yourself with the entire General Order and its attachments enclosed with this letter, which describes mandatory discharge and monitoring requirements. Sampling, monitoring and reporting requirements applicable to your treatment and disposal methods must be completed in accordance with the appropriate treatment system sections of the General Order and the attached **Monitoring and Reporting Program (MRP) No. 2014-0153-DWQ-R5340**. This MRP was developed after consideration of your waste characterization and site conditions described in the attached memorandum.

### **DISCHARGE DESCRIPTION**

Sugar Pine Christian Camps owns and operates Camp Sugar Pine and the associated wastewater treatment system, with assistance from Central Cal Waterworks, Inc. The

camp is located at 48478 Mill Canyon Road, Oakhurst, about three-quarters of a mile northwest of the unincorporated community of Sugar Pine (shown in Attachment A). Camp Sugar Pine discharges domestic wastewater generated from toilets, showers, food preparation, and washing machines to the Facility for treatment and disposal. According to the Report of Waste Discharge (RWD), estimated wastewater flows at the Camp are about 14,000 gpd in the summer and around 7,000 gpd in the winter.

The Facility consists of the following: a 10,000-gallon septic tank, a 2,500-gallon septic tank, and a lift station at the Main Camp area; a 2,500-gallon septic tank at the Timber Mountain area; an Aerated Pond; and two evaporation/percolation ponds (referred to as Ponds #1 and #2) (depicted in Attachment B). The evaporation/percolation pond in use is changed two or three times per year. Attachment C includes a facility flow schematic.

The Aerated Pond is currently in need of repair. Consequently, the Discharger is currently bypassing the Aerated Pond and discharging wastewater directly to Pond #1 or Pond #2. Further details regarding the Aerated Pond's condition are provided in the enclosed memorandum.

### **FACILITY SPECIFIC REQUIREMENTS AND EFFLUENT LIMITATIONS**

The Discharger will maintain exclusive control over the discharge and shall comply with the terms and conditions of this NOA, General Order 2014-0153-DWQ, with all attachments, and MRP No. 2014-0153-DWQ-R5340.

In accordance with Section B.1 of the General Order, **the daily discharge from the lift station to the aerated pond or evaporation/percolation ponds shall not exceed 20,000 gallons per day (gpd) as a monthly average.** In accordance with the requirements of the General Order, this NOA does not specify a nitrogen effluent limitation since the permitted monthly average Facility flow rate does not exceed 20,000 gpd.

The General Order states in Section B.1 that the Discharger shall comply with the setbacks as described in Table 3 of the General Order. This table summarizes the different setback requirements for wastewater treatment system equipment, activities, land application areas, and storage and/or treatment ponds from sensitive receptors and property lines where applicable. The Discharger shall comply with the applicable requirements, as summarized in the following table.

**Table 1: Site Specific Applicable Setback Requirements**

<b>Equipment or Activity</b>	<b>Domestic Well</b>	<b>Flowing Stream</b>	<b>Ephemeral Stream</b>	<b>Property Line</b>
Septic Tank, Treatment System, or Collection System	150 ft.	50 ft. (see note 1)	50 ft.	5 ft
Impoundment (undisinfected secondary recycled water)	150 ft.	150 ft.	150 ft.	50 ft.

1. The lift/pump station is less than 50 feet from Lewis Creek. Section B.1.I. of the General Order states noncomplying existing sites may be permitted if nuisance

conditions do not result from the noncompliance. As discussed in further detail in the enclosed memorandum, the less than 50 foot setback distance for the lift/pump station is acceptable provided it does not result in noncompliance with the NOA and General Order (e.g., wastewater overflow into Lewis Creek).

The Discharger shall comply with all applicable sections of the General Order, including:

1. Septic System Requirements (Section B.2);
2. Pond System Requirements (Section B.5);
3. Sludge/Solids/Biosolids Disposal Requirements (Section B.8); and
4. Groundwater and Surface Water Limitations (Section C.1)

Provision E.1 of the General Order requires dischargers enrolled under the General Order to prepare and implement the following reports by **14 October 2020** of the issuance of the NOA:

- Spill Prevention and Emergency Response Plan (Provision E.1.a.).
- Sampling and Analysis Plan (Provision E.1.b).
- Sludge Management Plan (Provision E.1.c)

A copy of these reports shall be maintained at the treatment facility and shall be presented to the Regional Water Board staff upon request. The Sludge Management Plan must be submitted to the Central Valley Water Board by **14 October 2020**.

As stated in Section E.2.w., in the event any change in control or ownership of the Facility or wastewater disposal areas, the Discharger must notify the succeeding owner or operator of the existence of this General Order by letter, a copy of which shall be immediately forwarded to the Central Valley Water Board Executive Officer.

Failure to comply with the requirements in this NOA, General Order 2014-0153-DWQ, with all attachments, and MRP No. 2014-0153-DWQ-R5340 could result in an enforcement action as authorized by provisions of the California Water Code. Discharge of wastes other than those described in this NOA is prohibited. If the method of waste disposal changes from that described in this NOA, you must submit a new Report of Waste Discharge describing the new operation. If wastewater flows to the Facility substantially increase and monthly average flows approach or exceed 20,000 gpd, the Central Valley Water Board staff must be contacted to determine if further analysis is required.

The required annual fee specified in the annual billing from the State Water Board shall be paid until this NOA is officially terminated. You must notify this office in writing if the discharge regulated by the General Order ceases, so that we may terminate coverage and avoid unnecessary billing.

On 31 May 2018, the Central Valley Water Board adopted Basin Plan amendments incorporating new strategies for addressing ongoing salt and nitrate accumulation in the Central Valley as part of the Central Valley Salinity Alternatives for Long-Term Sustainability (**CV-SALTS**) initiative. Further details of these strategies are discussed in the enclosed memorandum. As these strategies are implemented, the Central Valley Water Board may find it necessary to modify the requirements of this NOA to ensure the goals of the Salt and Nitrate Control Program are met.

The Central Valley Water Board has gone to a Paperless Office System. All regulatory documents, submissions, materials, data, monitoring reports, and correspondence should be converted to a searchable Portable Document Format (PDF) and submitted electronically. Documents that are less than 50MB should be emailed to: [centralvalleyfresno@waterboards.ca.gov](mailto:centralvalleyfresno@waterboards.ca.gov). Documents that are 50MB or larger should be transferred to a disk and mailed to the Central Valley Water Board office at 1685 E Street, Fresno, CA 93706. To ensure that your submittals are routed to the appropriate staff, the following information block should be included in any email used to transmit documents to this office:

**Program:** Non-15  
**Place ID:** 212973  
**Facility Name:** Camp Sugar Pine  
**Order:** 2014-0153-DWQ-R5340

In order to conserve paper and reduce mailing costs, a paper copy of the General Order has been sent only to the Discharger. Others are advised that the [General Order](#) is available on the State Water Board's website ([http://www.waterboards.ca.gov/board\\_decisions/adopted\\_orders/water\\_quality/2014/wqo2014\\_0153\\_dwq.pdf](http://www.waterboards.ca.gov/board_decisions/adopted_orders/water_quality/2014/wqo2014_0153_dwq.pdf)).

All documents, including responses to inspections and written notifications, submitted to comply with this NOA shall be directed, via the paperless office system, to the Compliance and Enforcement Unit, attention to Russell Walls. Mr. Walls can be reached at (559) 488-4392 or [Russell.Walls@waterboards.ca.gov](mailto:Russell.Walls@waterboards.ca.gov). Questions regarding the permitting aspects of the NOA, and notification for termination of coverage under the Small Domestic General Order, shall be directed, via the paperless office system, to the WDR Permitting Unit, attention Jeff Robins. Jeff Robins can be reached at (559) 445-5976 or by email at [Jeff.Robins@waterboards.ca.gov](mailto:Jeff.Robins@waterboards.ca.gov).

Any person aggrieved by this action of the Central Valley Water Board may petition the State Water Resources Control Board to review the action in accordance with California Water Code section 13320 and California Code of Regulations, title 23, sections 2050 and following. The State Water Resources Control Board must receive the petition by 5:00 p.m., 30 days after the date of this NOA, except that if the thirtieth day following the date of this Order falls on a Saturday, Sunday, or state holiday, the petition must be received by the State Water Resources Control Board by 5:00 p.m. on the next business day. [Copies of the law and regulations applicable to filing petitions](#) may be found on the internet ([http://www.waterboards.ca.gov/public\\_notices/petitions/water\\_quality](http://www.waterboards.ca.gov/public_notices/petitions/water_quality)) or will be provided upon request

If you have any questions regarding this matter, please contact Jeff Robins by phone at (559) 445-5976 or by email at [Jeff.Robins@waterboards.ca.gov](mailto:Jeff.Robins@waterboards.ca.gov).

*Original Signed by Clay L. Rodgers for:*  
Patrick Pulupa  
Executive Officer

Attachments:

- Attachment A – Location Map
- Attachment B –Wastewater Ponds Map
- Attachment C – Flow Schematic

Enclosures:

- Monitoring and Reporting Program 2014-0153-DWQ-R5340
- 16 July 2020 Review Memorandum for Camp Sugar Pine WWTF
- State Water Resources Control Board WQ 2014-0153-DWQ (Discharger Only)

cc:

- Laurel Warddrip, Senior Scientist, State Water Resources Control Board, Division of Water Quality, Sacramento (via email)
- Adam Forbes, Senior Engineer, State Water Resources Control Board, Division of Drinking Water, Fresno (via email)
- Russell Walls, Senior Engineer, Central Valley Water Board, Compliance and Enforcement Unit, Fresno (via email)
- Madera County Environmental Health Services, Madera
- Madera County Planning Department, Madera
- Garth Pecchinino, QK, Inc. Clovis (via email)

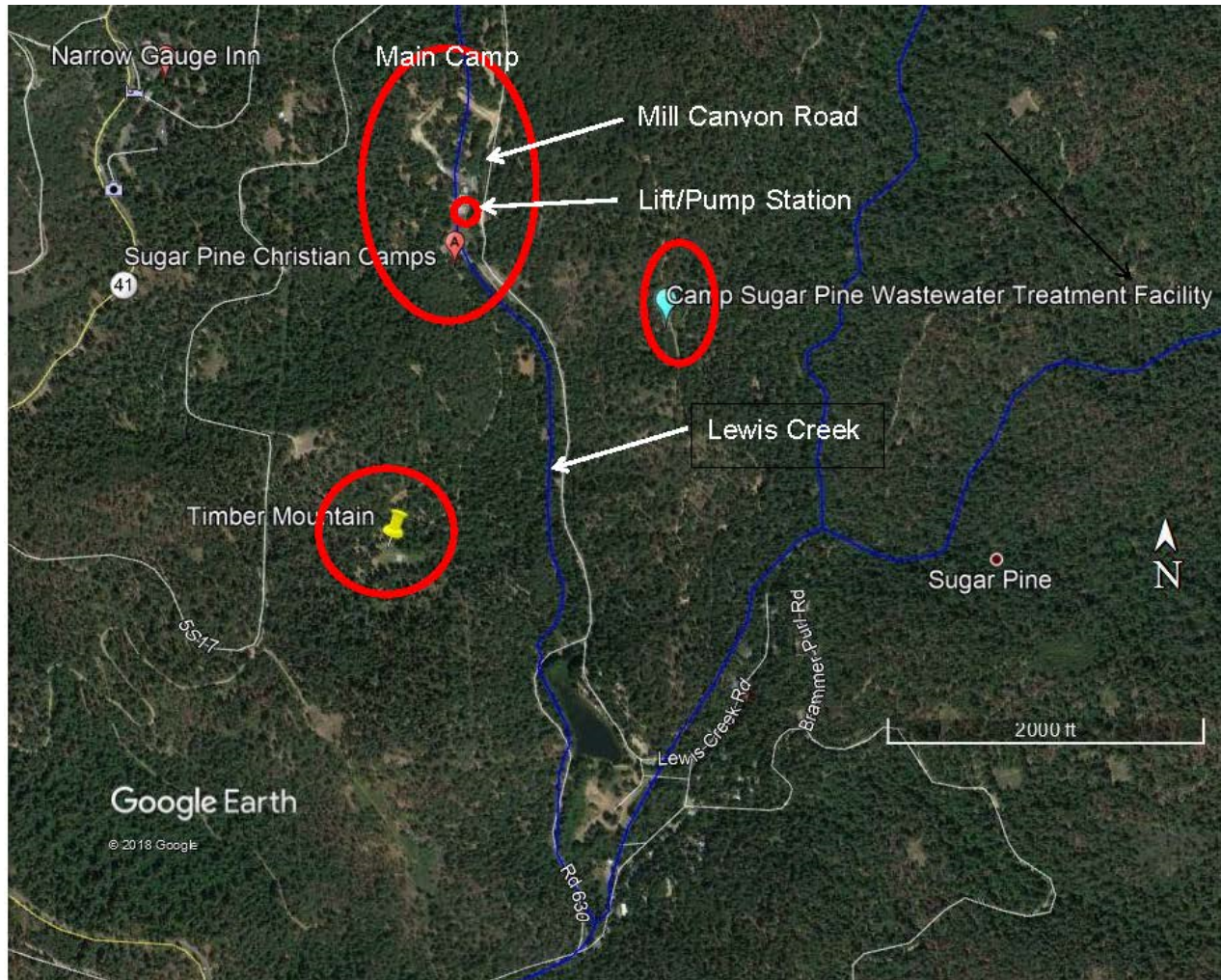

**ATTACHMENT A – LOCATION MAP**  
NOTICE OF APPLICABILITY 2014-0153-DWQ-R5340  
FOR  
SUGAR PINE CHRISTIAN CAMPS  
CAMP SUGAR PINE WASTEWATER TREATMENT SYSTEM  
MADERA COUNTY



**ATTACHMENT B – WASTEWATER PONDS MAP**  
NOTICE OF APPLICABILITY 2014-0153-DWQ-R5340  
FOR  
SUGAR PINE CHRISTIAN CAMPS  
CAMP SUGAR PINE WASTEWATER TREATMENT SYSTEM  
MADERA COUNTY

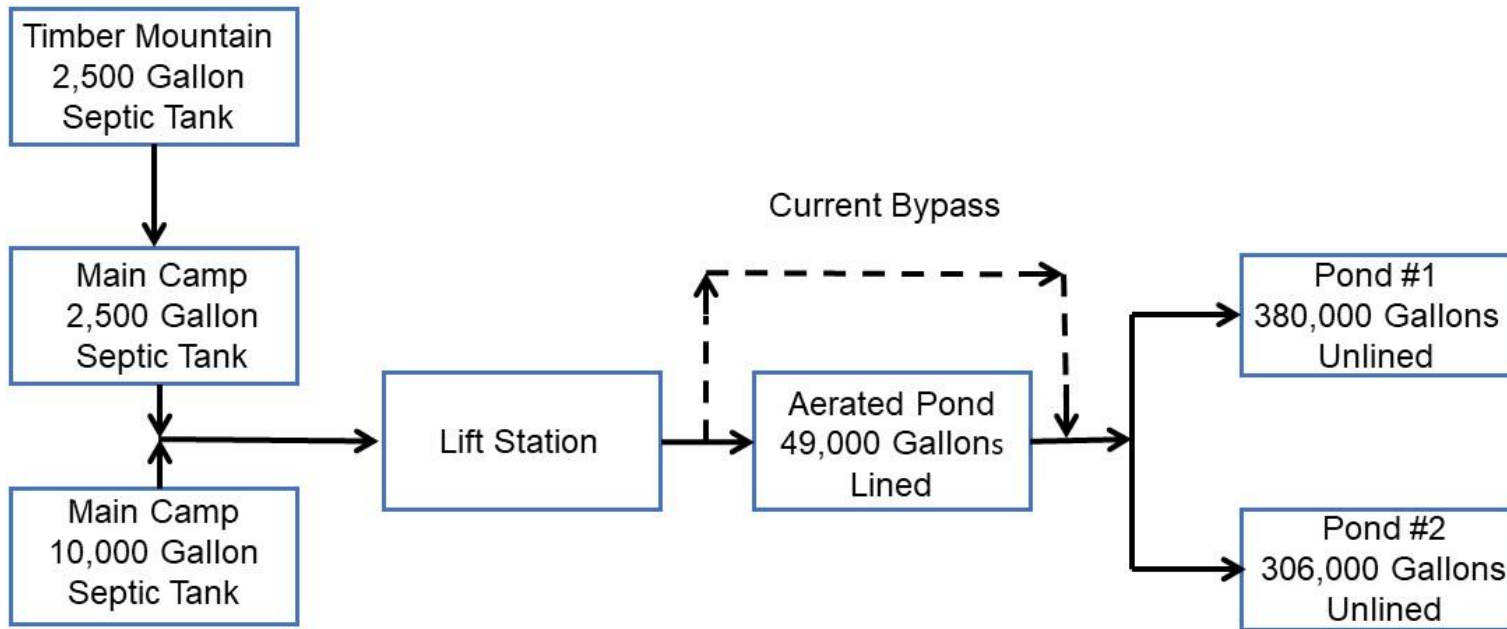

**ATTACHMENT C – FLOW SCHEMATIC**  
 NOTICE OF APPLICABILITY 2014-0153-DWQ-R5340  
 FOR  
 SUGAR PINE CHRISTIAN CAMPS;  
 CAMP SUGAR PINE WASTEWATER TREATMENT SYSTEM  
 MADERA COUNTY



**CALIFORNIA REGIONAL WATER QUALITY CONTROL BOARD  
CENTRAL VALLEY REGION**

**MONITORING AND REPORTING PROGRAM NO. 2014-0153-DWQ-R5340  
FOR  
SUGAR PINES CHRISTIAN CAMPS  
CAMP SUGAR PINE WASTEWATER TREATMENT SYSTEM  
MADERA COUNTY**

This Monitoring and Reporting Program (MRP) describes requirements for monitoring a wastewater treatment system. This MRP is issued pursuant to Water Code section 13267. Sugar Pine Christian Camps (Discharger) shall not implement any changes to this MRP unless and until a revised MRP is issued by the Regional Water Quality Control Board, Central Valley Region (Central Valley Water Board) or Executive Officer.

Section 13267 of the California Water Code states, in part:

*“In conducting an investigation specified in subdivision (a), the regional board may require that any person who has discharged, discharges, or is suspected of having discharged or discharging, or who proposes to discharge waste within its region, or any citizen or domiciliary, or political agency or entity of this state who has discharged, discharges, or is suspected of having discharged or discharging, or who proposes to discharge, waste outside of its region that could affect the quality of waters within its region shall furnish, under penalty of perjury, technical or monitoring program reports which the regional board requires. The burden, including costs, of these reports shall bear a reasonable relationship to the need for the report and the benefits to be obtained from the reports. In requiring those reports, the regional board shall provide the person with a written explanation with regard to the need for the reports and shall identify the evidence that supports requiring that person to provide the reports.”*

Section 13268 of the California Water Code states, in part:

*“(a) Any person failing or refusing to furnish technical or monitoring program reports as required by subdivision (b) of Section 13267, or failing or refusing to furnish a statement of compliance as required by subdivision (b) of Section 13399.2, or falsifying and information provided therein, is guilty of a misdemeanor and may be liable civilly in accordance with subdivision (b).*

*(b)(1) Civil liability may be administratively imposed by a regional board in accordance with Article 2.5 (commencing with section 13323) of Chapter 5 for a violation of subdivision (a) in an amount which shall not exceed one thousand dollars (\$1,000) for each day in which the violation occurs.”*

The Discharger owns and operates Camp Sugar Pine Wastewater Treatment System (Facility or WWTF) that is subject to the Notice of Applicability (NOA)

---

**KARL E. LONGLEY ScD, P.E., CHAIR | PATRICK PULUPA, ESQ., EXECUTIVE OFFICER**

---

1685 E Street, Fresno, CA 93706 | [www.waterboards.ca.gov/centralvalley](http://www.waterboards.ca.gov/centralvalley)

2014-0153-DWQ-R5340. The NOA enrolls the Facility under State Water Resources Control Board Order WQ 2014-0153-DWQ, *General Waste Discharge Requirements for Small Domestic Treatment Systems* (General Order) upon the rescission of WDRs Order 87-031. The reports are necessary to ensure that the Discharger complies with the NOA and General Order. Pursuant to Water Code section 13267, the Discharger shall implement this MRP and shall submit the monitoring reports described herein.

All samples shall be representative of the volume and nature of the discharge or matrix of material sampled. The name of the sampler, sample type (grab or composite), time, date, location, bottle type, and any preservative used for each sample shall be recorded on the sample chain of custody form. The chain of custody form must also contain all custody information including date, time, and to whom samples were relinquished. If composite samples are collected, the basis for sampling (time or flow weighted) shall be approved by Central Valley Water Board staff.

Field test instruments (such as those used to test pH, dissolved oxygen, and electrical conductivity) may be used provided that they are used by a State Water Resources Control Board, Environmental Laboratory Accreditation Program (ELAP) certified laboratory, or:

1. The user is trained in proper use and maintenance of the instruments;
2. The instruments are field calibrated prior to monitoring events at the frequency recommended by the manufacturer;
3. Instruments are serviced and/or calibrated by the manufacturer at the recommended frequency; and
4. Field calibration reports are maintained and available for at least three years.

If monitoring consistently shows no significant variation in magnitude of a constituent concentration or parameter after at least 12 months of monitoring, the Discharger may request this MRP be revised to reduce monitoring frequency. The proposal must include adequate technical justification for reduction in monitoring frequency.

### **SEPTIC TANK (COLLECTION SYSTEM) MONITORING**

All septic tanks shall be inspected and/or pumped at least as frequently as described below in Table 1. Inspections of sludge and scum depth are not required if the tanks are pumped at least annually.

**Table 1 - Septic Tank Monitoring Requirements**

<b>Parameter</b>	<b>Units</b>	<b>Measurement Type</b>	<b>Inspection/Reporting Frequency</b>
Sludge depth and scum thickness in each compartment of each tank	Inches	Staff Gauge	Annually
Distance between bottom of scum layer and bottom of outlet device	Inches	Staff Gauge	Annually
Distance between top of sludge layer and bottom of outlet device	Inches	Staff Gauge	Annually

<b>Parameter</b>	<b>Units</b>	<b>Measurement Type</b>	<b>Inspection/Reporting Frequency</b>
Effluent filter condition (if equipped, clean as needed)	NA	NA	Annually

Septic tanks shall be pumped when any one of the following conditions exists:

1. The combined thickness of sludge and scum exceeds one third of the tank depth of this first compartment.
2. The scum layer is within 3 inches of the outlet device.
3. The sludge layer is within 8 inches.

If a septic tank is pumped during the year, the pumping report shall be submitted with the annual report. All pumping reports shall be submitted with the next regularly scheduled monitoring report. At a minimum, the record shall include the date, nature of service, service company name, and service company license number.

## **POND SYSTEM MONITORING**

### Influent Monitoring

Influent samples shall be taken at a location that provides representative samples of the wastewater and flow rate prior to discharge to any pond (e.g., at the lift station). At a minimum, influent monitoring shall consist of the following:

**Table 2 - Pond Influent Monitoring Requirements**

<u>Constituent</u>	<u>Units</u>	<u>Sample Type</u>	<u>Sample Frequency</u>	<u>Reporting Frequency</u>
Flow	gpd	Meter (See 1 below)	Continuous (see 2 below)	Annually
BOD <sub>5</sub>	mg/L	Grab	Monthly (see 3 below)	Quarterly
EC	µmhos/cm	Grab	Monthly (see 3 below)	Quarterly
Total Nitrogen	mg/L	Grab	Quarterly (see 4 below)	Quarterly

1. Flow rate may be metered or estimated based on the potable water supply meter readings or other approved method. Flow rates may be measured as influent or effluent flow.
2. For continuous analyzers, the Discharger shall report documented routine meter maintenance activities including date, time of day, and duration, in which the analyzer(s) is not in operation.
3. Once the Aerated Pond is repaired and put back into use, the minimum sampling frequency of these constituents can be reduced to quarterly.

- Once the Aerated Pond is repaired and put back into use, the minimum influent sampling frequency for total nitrogen can be reduced to annually. The annual total nitrogen sample shall be conducted during the third quarter (July – September).

Effluent Monitoring

Effluent samples shall be taken at a location that represents the effluent quality discharged from the Aerated Pond to the Evaporation/Percolation Ponds. Sampling shall begin once the Aerated Pond is repaired and back in service. At a minimum, effluent monitoring shall consist of the following.

**Table 3 - Effluent Monitoring Requirements**

<u>Constituent</u>	<u>Units</u>	<u>Sample Type</u>	<u>Sample Frequency</u>	<u>Reporting Frequency</u>
EC	µmhos/cm	Grab	Monthly	Quarterly
BOD <sub>5</sub>	mg/L	Grab	Monthly	Quarterly
Total Nitrogen	mg/L	Grab	Quarterly	Quarterly

Pond Monitoring

All wastewater treatment and disposal ponds shall be monitored as specified below.

**Table 4 - Pond Monitoring Requirements**

<u>Constituent</u>	<u>Units</u>	<u>Sample Type</u>	<u>Sample Frequency</u>	<u>Reporting Frequency</u>
DO (see 1 below)	mg/L	Grab	Monthly	Quarterly
Freeboard	0.1 feet	Measurement	Monthly	Quarterly
Odors	--	Observation	Monthly	Quarterly
Berm Condition	--	Observation	Monthly	Quarterly

- DO shall be measured between 8:00 am and 10:00 am and shall be taken opposite the pond inlet at a depth of approximately one foot. Should the DO be below 1.0 mg/L during a weekly sampling event, the Discharger shall take all reasonable steps to correct the problem and commence daily DO monitoring in the affected ponds until the problem has been resolved.

**SLUDGE/BIOSOLIDS MONITORING**

The Discharger shall report the handling and disposal of all solids (e.g., screenings, grit, sludge, biosolids, solids from pond dredging, etc.) generated at the wastewater system. Records shall include the name/contact information for the hauling company, the type and amount of waste transported, the date removed from the wastewater system, the disposal facility name and address, and copies of analytical data required by the entity accepting the waste. These records shall be submitted as part of the annual monitoring report.

## REPORTING

In reporting monitoring data, the Discharger shall arrange the data in tabular form so that the date, sample type (e.g., effluent, solids, etc.), and reported analytical or visual inspection results are readily discernable. The data shall be summarized to clearly illustrate compliance with the General Order and NOA as applicable. The results of any monitoring done more frequently than required at the locations specified in the MRP shall be reported in the next regularly scheduled monitoring report and shall be included in calculations as appropriate.

All regulatory documents, submissions, materials, data, monitoring reports, and correspondence should be converted to a searchable Portable Document Format (PDF) and submitted electronically. Documents that are less than 50MB should be emailed to: [centralvalleyfresno@waterboards.ca.gov](mailto:centralvalleyfresno@waterboards.ca.gov). Documents that are 50MB or larger should be transferred to a disk and mailed to the appropriate Regional Water Board office, in this case 1685 E Street, Fresno, CA 93706. To ensure that your submittals are routed to the appropriate staff, the following information block should be included in any email used to transmit documents to this office:

**Program:** Non-15,  
**Place ID:** 212973,  
**Facility Name:** Camp Sugar Pine,  
**Order:** 2014-0153-DWQ-R5340

### A. Quarterly Monitoring Reports

Quarterly reports shall be submitted to the Regional Water Board on the **first day of the second month after the quarter ends** (e.g. the January-March Quarterly Report is due by May 1<sup>st</sup>). The reports shall bear the certification and signature of the Discharger's authorized representative. At the minimum, the quarterly reports shall include:

1. Results of all required monitoring.
2. A comparison of monitoring data to the requirements (including the flow limitation), disclosure of any violations of the NOA and/or General Order, and an explanation of any violation of those requirements. Data shall be presented in tabular format.
3. Copies of laboratory analytical report(s) and chain of custody form(s).
4. An update on the status of repairing the Aerated Pond and putting it back into service.

### B. Annual Report

Annual Reports shall be submitted to the Regional Water Board **by March 1<sup>st</sup> following the monitoring year**. The Annual Report shall include the following:

1. Tabular and graphical summaries of all monitoring data collected during the year.
2. An evaluation of the performance of the wastewater treatment system, including discussion of the capacity issues, nuisance conditions, system problems, and a forecast of the flows anticipated in the next year. A flow rate evaluation, as described in the General Order (Provision E.2.c), shall also be submitted.
3. A discussion of compliance and the corrective action taken, as well as any planned or proposed actions needed to bring the discharge into compliance with the NOA and/or General Order.
4. A discussion of any data gaps and potential deficiencies/redundancies in the monitoring system or reporting program.
5. The name and contact information for the wastewater operator responsible for operation, maintenance, and system monitoring.
6. Records of all sludge/biosolids removed from the wastewater treatment system.

A letter transmitting the monitoring reports shall accompany each report. The letter shall report violations found during the reporting period, and actions taken or planned to correct the violations and prevent future violations. The transmittal letter shall contain the following penalty of perjury statement and shall be signed by the Discharger or the Discharger's authorized agent:

*"I certify under penalty of law that I have personally examined and am familiar with the information submitted in this document and all attachments and that, based on my inquiry of those individuals immediately responsible for obtaining the information, I believe that the information is true, accurate, and complete. I am aware that there are significant penalties for submitting false information, including the possibility of fine and imprisonment."*

The Discharger shall implement the above monitoring program in the first month following the rescission of Waste Discharge Requirements Order 87-031.

Ordered by:

Original Signed by Clay L. Rodgers for  
PATRICK PULUPA, Executive Officer

7/16/2020

(Date)

## **GLOSSARY**

BOD <sub>5</sub>	Five-day biochemical oxygen demand
CaCO <sub>3</sub>	Calcium carbonate
DO	Dissolved oxygen
EC	Electrical conductivity at 25° C
FDS	Fixed dissolved solids
TDS	Total dissolved solids
TKN	Total Kjeldahl nitrogen
TSS	Total suspended solids
Continuous	The specified parameter shall be measured by a meter continuously.
24-hr Composite	Samples shall be a flow-proportioned composite consisting of at least eight aliquots over a 24-hour period.
Daily	Every day except weekends or holidays.
Twice Weekly	Twice per week on non-consecutive days.
Weekly	Once per week.
Twice Monthly	Twice per month during non-consecutive weeks.
Monthly	Once per calendar month.
Quarterly	Once per calendar quarter.
Semiannually	Once every six calendar months (i.e., two times per year) during non-consecutive quarters.
Annually	Once per year.
mg/L	Milligrams per liter
mg/kg	Milligrams per kilogram
mL/L	Milliliters [of solids] per liter
µg/L	Micrograms per liter
µmhos/cm	Micromhos per centimeter
gpd	Gallons per day
mgd	Million gallons per day
MDL	Method Detection Limit
MPN/100 mL	Most probable number [of organisms] per 100 milliliters
NA	Denotes not applicable

---

## Central Valley Regional Water Quality Control Board

**TO:** Scott J. Hatton  
Supervising Water Resource Control Engineer

**FROM:** Alexander S. Mushegan  
Senior Water Resource Control Engineer  
RCE 84208

Jeff Robins  
Water Resource Control Engineer

**DATE:** 16 July 2020

**SUBJECT: APPLICABILITY OF COVERAGE UNDER STATE WATER RESOURCES CONTROL BOARD ORDER WQ-2014-0153-DWQ; GENERAL WASTE DISCHARGE REQUIREMENTS FOR SMALL DOMESTIC WASTEWATER TREATMENT SYSTEMS; SUGAR PINE CHRISTIAN CAMPS; CAMP SUGAR PINE WASTEWATER TREATMENT FACILITY; MADERA COUNTY**



On 27 September 2019, Central Valley Regional Water Quality Control Board (Central Valley Water Board) staff received a Report of Waste Discharge (RWD) prepared by QK, Inc., signed and stamped by Garth A. Pecchenino (RCE 52678) on behalf of Sugar Pine Christian Camps (Discharger) for its Camp Sugar Pine Wastewater Treatment System (Facility). The RWD included a completed and signed Form 200 and a technical report. Further information was submitted on 19 November 2019, 9 March 2020, 17 April 2020, 22 April 2020, 14 June 2020, and 19 June 2020. This memorandum provides a summary of the Central Valley Water Board staff's review of the September 2019 RWD and subsequent materials and the applicability of this discharge to be covered under State Water Resources Control Board (State Water Board) Water Quality Order 2014-0153-DWQ *General Water Discharge Requirements for Small Domestic Wastewater Treatment Systems* (General Order).

### BACKGROUND INFORMATION

Sugar Pine Christian Camps owns and operates Camp Sugar Pine and the associated wastewater treatment facility, with the assistance of Central Cal Waterworks Inc. The Facility is currently regulated under Waste Discharge Requirements Order 87-031. Camp Sugar Pine is located at 48478 Mill Canyon Road, Oakhurst, about three-quarters



of a mile northwest of the unincorporated community of Sugar Pine (as shown in Attachment A of the NOA) (Sections 35 and 36, Township 5 South, Range 21 East, Mount Diablo Base and Meridian [MDBM]). The camp was originally constructed and opened in 1954. Camp Sugar Pine consists of a Main Camp area and Timber Mountain area. The Main Camp area has guests all year. The Timber Mountain area operates from approximately May through October. Domestic wastewater generated from the Camp includes toilets, showers, food preparation, and washing machines.

The Facility consists of three septic tanks, a lift/pump station, an aerated pond (currently out of service), and two evaporation/percolation ponds. A 10,000-gallon septic tank, a 2,500-gallon septic tank, and the lift/pump station are in the Main Camp area. A second 2,500-gallon septic tank is in the Timber Mountain area. The evaporation/percolation ponds are approximately at 37° 26' 59" N and 119° 37' 55" W. The elevation difference between the lift station and the ponds is reportedly 262 feet.

Wastewater from the Timber Mountain area septic tank flows to the Main Camp area's 2,500-gallon septic tank. Wastewater from the Main Camp area's 2,500-gallon and 10,000-gallon septic tanks gravity flow to the lift station adjacent to Mill Canyon Road. The lift station consists of two pumps that alternate operation. The lift station can pump wastewater to the Aerated Pond and/or the evaporation/percolation ponds (Ponds #1 and #2). The Aeration Pond, Evaporation/Percolation Pond #1, and Evaporation/Percolation Pond #2 have estimated capacities of 49,000 gallons, 380,000 gallons, and 306,000 gallons, respectively.

As previously mentioned, the Aerated Pond is currently not in use. The Aerated Pond's liner was removed in 2015 because it had deteriorated, at which time the Discharger ceased using the Aerated Pond and began bypassing effluent directly to the evaporation/percolation ponds. The date the original liner was installed is not known, but the lined Aerated Pond was mentioned in the 1987 WDRs (Order 87-031). Reportedly once the liner is replaced, the aerator must be reinstalled (including electrical lines, timer, and securing cables), the bypass piping must be disconnected/removed, and then the Aerated Pond can be brought back into service. The Discharger intends to replace the liner, but with the current COVID-19 crisis, they are experiencing financial difficulties and reportedly cannot afford the repairs at this time.

### **POTENTIAL THREAT TO WATER QUALITY**

The RWD estimated wastewater flows based on the metered water supply. According to the RWD, the peak monthly average water supply flow was 13,808 gpd for the month of August, based on metered water supply records for the past ten years (2010 to 2019). The RWD estimates that of the 13,808 gpd, 11,560 gpd was used for domestic use and approximately 2,250 gpd was used for irrigation. The average winter flows, based on domestic water usage, are estimated to be approximately 7,000 gpd

This data appears to conflict with the flow data reported in the Discharger's self-monitoring reports (SMRs). The SMRs estimate wastewater flow by the number of guests (100 gpd per guest). For example, the SMRs reported a monthly average

domestic wastewater flow of 19,303 gpd in July 2017, but the monthly average water supply meter reading for July 2017 was 12,742 gpd. Since it appears the current method of estimating wastewater flow in the SMRs is inaccurate, the monitoring and reporting program should require the Discharger to estimate flow using potable water meter readings or reevaluate the current method for estimating wastewater flow.

The Camp's active water source is a groundwater well located on the east side of the Main Camp (37.4512° N, -119.6383° W). In addition to the well, there is an inactive spring water source that is available in the event of an emergency condition. The well is approximately 461 feet deep. The 2001 well completion report's geologic log profile consisted of the following: overburden from 0 to 4 feet below ground surface (bgs); decomposed granite from 4 to 7 feet bgs; creek bottom/riverbank/mud from 7 to 18 feet bgs; decomposed granite from 18 to 48 feet bgs; granite with fractures from 48 to 172 feet bgs; decomposed granite from 172 to 176 feet bgs; and granite with fractures from 176 to 462 feet bgs. The first water was encountered at a depth of 67 feet.

Table 3 of the General Order specifies setback distances enrollees must comply. The existing lift/pump station is less than 50 feet from Lewis Creek. Table 3 of the General Order specifies a setback distance of 50 feet from a collection system to a flowing stream. However, Requirement B.1.i. states that for some existing sites that cannot comply with a specified setback, the "*noncomplying sites may be permitted under this General Order if nuisance conditions do not result from the noncompliance.*" Reportedly, according to an employee of the Camp, there has not been an overflow from the lift/pump station to the stream in at least 30 years. Furthermore, Joseph Camarena with Sugar Pine Christian Camps submitted, on 8 July 2020, a list of procedures for the lift station that are implemented mitigate the potential for wastewater to overflow into the creek.

Order 87-031 indicates the design capacity of the Facility is 30,000 gpd. For enrollment under the General Order, the Discharger agreed to lower their flow limit to 20,000 gpd since their flows have been less than 20,000 gpd and since they have no plans to expand the number of visitors to their camp. Since the NOA will specify a flow limitation of 20,000 gpd, a nitrogen effluent limit evaluation is not required at this time.

Source water quality data for select parameters are summarized in Table 1 below. Besides nitrate, the reported results are from one sample collected in October 2005. For nitrate, the results are from 11 samples collected from 2004 to 2017.

**Table 1 – Source Water Well Data**

<b>Parameter</b>	<b>Result</b>	<b>Units</b>
EC	130	µmhos/cm
TDS	100	mg/L
Nitrate (as N)	ND (See note 1)	mg/L
pH	8.1	standard units
Total Alkalinity	43	mg/L as CaCO <sub>3</sub>
Hardness	20	mg/L as CaCO <sub>3</sub>
Sodium	27	mg/L

<b>Parameter</b>	<b>Result</b>	<b>Units</b>
Potassium	1	mg/L
Chloride	19.6	mg/L
Sulfate	6.9	mg/L
Magnesium	<2	mg/L

1. All results were reported non-detect (three detection limits were 0.4 mg/L and eight detection limits were 2.0 mg/L).

Historical groundwater data from three wells (Well 1: 006S021E25C001M, Well 2: 006S022E07Q001M, and Well 3: 005S021E35K001M) located within a 5-mile radius of the Facility are shown in Table 2 below. Groundwater data was obtained from the [National Water Quality Monitoring Council's Water Quality Portal](https://www.waterqualitydata.us/portal/) (<https://www.waterqualitydata.us/portal/>). If more than one sample result is given on a day, the results for that day are averaged and noted with the number of samples and the range of the results on the bottom line of the cell in the table.

**Table 2 - Groundwater Quality Data**

<b>Parameter</b>	<b>Units</b>	<b>Well 1</b>	<b>Well 2</b>	<b>Well 3</b>
Date Sampled	Year	31 May 2006	24 May 2006 25 May 2010 3 May 2016	16 May 2016 4 May 2016
Well Hole Depth	Feet	631	500	462
TDS	mg/L	180 2 (173-186)	98 3 (92-104)	103 2 (100-105)
EC	µmhos/cm	285 2 (284-286)	121 3 (113-126)	158 2 (155-160)
Nitrate (as N)	mg/L	ND (MDL = 0.06)	0.04 3 (0.02-0.066)	ND (MDL = 0.06/0.04)
Boron (Dissolved)	µg/L	318	1 3 (ND-2)	88 2(82-94)
Total Alkalinity (as CaCO <sub>3</sub> ) (Dissolved)	mg/L	98.2	61 3 (59.9-62.4)	36.0
Calcium (Dissolved)	mg/L	10.3	14 3 (13.6-15)	3.44 2 (3.44-3.44)
Chloride	mg/L	22.7	0.82 3 (0.75-0.96)	19 2 (18-19.2)
Total Hardness	mg/L as CaCO <sub>3</sub>	28	52.8 3 (49.2-55.4)	8.9 2 (8.9-8.92)
Magnesium (Dissolved)	mg/L	0.571	4.1 3 (3.69-4.2)	0.074 2 (0.073-0.074)
Potassium (Dissolved)	mg/L	0.64	1.37 3(1.25-1.49)	1.1 2 (1.06-1.1)

<u>Parameter</u>	<u>Units</u>	<u>Well 1</u>	<u>Well 2</u>	<u>Well 3</u>
Sodium (Dissolved)	mg/L	49.6	5.59 3 (5.32-5.91)	28 2 (27-29.8)
Sulfate (Dissolved)	mg/L	7.09	2.82 3 (2.58-3.05)	6.9 2 (6.69-7.15)
pH (see note 1 below)	pH Units	8.5 2 (8.5-8.6)	5.9 3 (5.6 – 6.8)	9.3 2 (9.2-9.4)

1. Average pH values were determined by converting the pH value to a hydrogen ion concentration, averaging the concentrations, and then taking the negative log of the average.

There is a storm drain in the paved area just south of the Chapel in the Main Camp area (Attachment B of the NOA). Reportedly, the storm water discharges to Lewis Creek just north of the bridge to the parking lot.

### **MONITORING REQUIREMENTS**

Monitoring requirements included in the following sections from Attachment C of the General Order are appropriate for this discharge:

- Septic Tank Monitoring
- Pond System Monitoring
- Solids Disposal

Additional monitoring is needed to further evaluate the Facility's discharge and impact to underlying groundwater as well as to ensure compliance with the Basin Plan.

### **SALT AND NITRATE CONTROL PROGRAMS**

As part of the Central Valley Salinity Alternatives for Long Term Sustainability (CV-SALTS) initiative, the Central Valley Water Board Adopted Basin Plan amendments incorporating new programs for addressing ongoing salt and nitrate ion accumulation in the Central Valley at its 31 May 2018 Board Meeting (Resolution R5-2018-0034). On 16 October 2019, the State Water Resources Control Board adopted Resolution No. 2019-0057 approving the Central Valley Water Board Basin Plan amendments and also directed the Central Valley Water Board to make targeted revisions to the Basin Plan amendments within one year from the approval of the Basin Plan amendments by the Office of Administrative Law. The Office of Administrative Law approved the Basin Plan amendments on 15 January 2020 (OAL Matter No. 2019-1203-03).

Pursuant to the Basin Plan amendments, dischargers will receive a Notice to Comply with instructions and obligations for the Salt Control Program within one year of the effective date of the amendments. Upon receipt of the Notice to Comply, the Discharger will have no more than six months to inform the Central Valley Water Board of their choice between Option 1 (Conservative Option for Salt Permitting) or Option 2 (Alternative Option for Salt Permitting). For the Nitrate Control Program, the Facility is in a non-prioritized basin/sub-basin. Implementation within a non-prioritized basin/sub-

basin will occur as directed by the Central Valley Water Board Executive Officer. More information on the [Salt and Nitrate Control Program](https://www.cvsalinity.org/public-info) may be found on the Internet. (<https://www.cvsalinity.org/public-info>).