

CALIFORNIA REGIONAL WATER QUALITY CONTROL BOARD

CENTRAL VALLEY REGION

11020 Sun Center Drive, #200 Rancho Cordova, California 95670-6114
 Phone (916) 464-3291 • Fax (916) 464-4645
 http://www.waterboards.ca.gov/centralvalley

**ORDER R5-2012-XXXX
 NPDES NO. CA0083828**

**WASTE DISCHARGE REQUIREMENTS FOR THE
 CLEAR CREEK COMMUNITY SERVICES DISTRICT
 CLEAR CREEK COMMUNITY SERVICES DISTRICT WATER TREATMENT PLANT
 SHASTA COUNTY**

The following Discharger is subject to waste discharge requirements as set forth in this Order:

Table 1. Discharger Information

Discharger	Clear Creek Community Services District
Name of Facility	Clear Creek Community Services District Water Treatment Plant
Facility Address	Paige Bar Road
	Igo, CA 96047
	Shasta County
The U.S. Environmental Protection Agency (USEPA) and the Regional Water Quality Control Board have classified this discharge as a minor discharge.	

The discharge by the Clear Creek CSD from the discharge points identified below is subject to waste discharge requirements as set forth in this Order:

Table 2. Discharge Location

Discharge Point	Effluent Description	Discharge Point Latitude	Discharge Point Longitude	Receiving Water
001	Settled filter backwash water and filter rinse water	40° 35' 53" N	122° 31' 52" W	Clear Creek

Table 3. Administrative Information

This Order was adopted by the Regional Water Quality Control Board on:	<Adoption Date>
This Order shall become effective on:	<Effective Date>
This Order shall expire on:	<Expiration Date>
The Discharger shall file a Report of Waste Discharge in accordance with title 23, California Code of Regulations, as application for issuance of new waste discharge requirements no later than:	<180 days prior to the Order expiration date OR insert date>

I, **Pamela C. Creedon**, Executive Officer, do hereby certify that this Order with all attachments is a full, true, and correct copy of an Order adopted by the California Regional Water Quality Control Board, Central Valley Region, on **<Adoption Date>**.

Pamela C. Creedon, Executive Officer

TENTATIVE DRAFT

Table of Contents

I. Facility Information 3
 II. Findings 4
 III. Discharge Prohibitions 10
 IV. Effluent Limitations and Discharge Specifications 11
 A. Effluent Limitations – Discharge Point No. 001 11
 B. Land Discharge Specifications – Not Applicable 11
 C. Reclamation Specifications – Not Applicable 11
 V. Receiving Water Limitations 12
 A. Surface Water Limitations 12
 B. Groundwater Limitations 14
 VI. Provisions 15
 A. Standard Provisions 15
 B. Monitoring and Reporting Program Requirements 19
 C. Special Provisions 19
 1. Reopener Provisions 19
 2. Special Studies, Technical Reports and Additional Monitoring Requirements 20
 3. Best Management Practices and Pollution Prevention – Not Applicable 23
 4. Construction, Operation and Maintenance Specifications 23
 5. Special Provisions for Municipal Facilities (POTWs Only) – Not Applicable 24
 6. Other Special Provisions 24
 7. Compliance Schedules – Not Applicable 24
 VII. Compliance Determination 25

List of Tables

Table 1. Discharger Information 1
 Table 2. Discharge Location 1
 Table 3. Administrative Information 1
 Table 4. Facility Information 3
 Table 5. Basin Plan Beneficial Uses 6
 Table 6. Effluent Limitations 11

List of Attachments

Attachment A – Definitions A-1
 Attachment B – Maps A-1
 Attachment C – Flow Schematic A-1
 Attachment D – Standard Provisions D-1
 Attachment E – Monitoring and Reporting Program E-1
 Attachment F – Fact Sheet F-1
 Attachment G – Summary of Reasonable Potential Analysis G-1
 Attachment H – Calculation of WQBELs H-1
 Attachment I – Effluent and Receiving Water Characterization Study I-1

TENTATIVE DRAFT

I. FACILITY INFORMATION

The following Discharger is subject to waste discharge requirements as set forth in this Order:

Table 4. Facility Information

Discharger	Clear Creek Community Services District
Name of Facility	Clear Creek Community Services District Water Treatment Plant
Facility Address	Paige Bar Road
	Igo, CA 96047
	Shasta County
Facility Contact, Title, and Phone	Ronald Carlin, Plant Operator, (530) 357-2121
Mailing Address	5880 Oak Street, Anderson, CA 96007
Type of Facility	Water treatment plant (SIC Code 4941)
Facility Design Flow	1.5 million gallons per day (MGD)

TENTATIVE DRAFT

II. FINDINGS

The California Regional Water Quality Control Board, Central Valley Region (hereinafter Central Valley Water Board), finds:

A. Background. The Clear Creek Community Services District (hereinafter Discharger) is currently discharging pursuant to Order No. R5-2006-0116 and National Pollutant Discharge Elimination System (NPDES) Permit No. CA0083828. The Discharger submitted a Report of Waste Discharge, dated 2 June 2011, and applied for a NPDES permit renewal to discharge up to 1.5 MGD of treated wastewater from the Clear Creek Community Services District Water Treatment Plant, hereinafter Facility. The application was deemed complete on 22 June 2011.

For the purposes of this Order, references to the “discharger” or “permittee” in applicable federal and state laws, regulations, plans, or policy are held to be equivalent to references to the Discharger herein.

B. Facility Description. The Discharger owns and operates a municipal potable water treatment plant that provides up to 25 MGD of potable drinking water to domestic and agricultural customers in its service area. Raw water supply comes directly from the Whiskeytown Dam outlet works. Production of the potable drinking water involves chlorination; coagulation; filtration through eight horizontal, multi-cell pressure filters, and post-chlorination. As part of the process, up to 1.5 MGD of filter backwash water is generated. The filter backwash water is sent to the three onsite settling ponds. The settling ponds are unlined. Supernatant from the settling ponds is discharged via a steep, rocky drainage ditch from Discharge Point No. 001 (see table on cover page) to Clear Creek, a water of the United States, and a tributary to the Sacramento River within the Sacramento – Upper Clear Watershed. Attachment B provides a map of the area around the Facility. Attachment C provides a flow schematic of the Facility.

C. Legal Authorities. This Order is issued pursuant to section 402 of the Clean Water Act (CWA) and implementing regulations adopted by USEPA and chapter 5.5, division 7 of the California Water Code (Water Code; commencing with section 13370). It shall serve as a NPDES permit for point source discharges from this facility to surface waters. This Order also serves as Waste Discharge Requirements (WDRs) pursuant to article 4, chapter 4, division 7 of the Water Code (commencing with section 13260).

D. Background and Rationale for Requirements. The Central Valley Water Board developed the requirements in this Order based on information submitted as part of the application, through monitoring and reporting programs, and other available information. The Fact Sheet (Attachment F), which contains background information and rationale for Order requirements, is hereby incorporated into this Order and constitutes part of the Findings for this Order. Attachments A through E and G through I are also incorporated into this Order.

TENTATIVE DRAFT

E. California Environmental Quality Act (CEQA). Under Water Code section 13389, this action to adopt an NPDES permit is exempt from the provisions of CEQA, Public Resources Code sections 21100-21177.

F. Technology-based Effluent Limitations. Section 301(b) of the CWA and implementing USEPA permit regulations at section 122.44, title 40 of the Code of Federal Regulations (40 CFR 122.44), require that permits include conditions meeting applicable technology-based requirements at a minimum, and any more stringent effluent limitations necessary to meet applicable water quality standards. The discharge authorized by this Order must meet minimum federal technology-based requirements based on Best Professional Judgment (BPJ) in accordance with 40 CFR 125.3. A detailed discussion of the technology-based effluent limitations development is included in the Fact Sheet.

G. Water Quality-based Effluent Limitations (WQBELs). Section 301(b) of the CWA and 40 CFR 122.44(d) require that permits include limitations more stringent than applicable federal technology-based requirements where necessary to achieve applicable water quality standards.

40 CFR 122.44(d)(1)(i) mandates that permits include effluent limitations for all pollutants that are or may be discharged at levels that have the reasonable potential to cause or contribute to an exceedance of a water quality standard, including numeric and narrative objectives within a standard. Where reasonable potential has been established for a pollutant, but there is no numeric criterion or objective for the pollutant, WQBELs must be established using: (1) USEPA criteria guidance under CWA section 304(a), supplemented where necessary by other relevant information; (2) an indicator parameter for the pollutant of concern; or (3) a calculated numeric water quality criterion, such as a proposed state criterion or policy interpreting the state's narrative criterion, supplemented with other relevant information, as provided in 40 CFR 122.44(d)(1)(vi).

H. Water Quality Control Plans. The Central Valley Water Board adopted a *Water Quality Control Plan, Fourth Edition (Revised October 2011)*, for the Sacramento and San Joaquin River Basins (hereinafter Basin Plan) that designates beneficial uses, establishes water quality objectives, and contains implementation programs and policies to achieve those objectives for all waters addressed through the plan. In addition, the Basin Plan implements State Water Resources Control Board (State Water Board) Resolution No. 88-63, which established state policy that all waters, with certain exceptions, should be considered suitable or potentially suitable for municipal or domestic supply. Beneficial uses applicable to Clear Creek are as follows:

TENTATIVE DRAFT

Table 5. Basin Plan Beneficial Uses

Discharge Point	Receiving Water Name	Beneficial Use(s)
001	Clear Creek	<u>Existing:</u> Municipal and domestic supply (MUN); Agricultural supply, including irrigation and stock watering (AGR); Water contact recreation, including canoeing and rafting (REC-1); Non-contact water recreation (REC-2); Warm freshwater habitat (WARM); Cold freshwater habitat (COLD); Migration of aquatic organisms, cold (MIGR); Spawning, reproduction, and/or early development, warm and cold (SPWN); and Wildlife habitat (WILD).
--	Groundwater	<u>Existing:</u> Municipal and domestic supply (MUN); Agricultural supply (AGR); Industrial service supply (IND); and Industrial process supply (PRO).

TENTATIVE DRAFT

The Basin Plan includes a list of Water Quality Limited Segments (WQLSs), which are defined as “...*those sections of lakes, streams, rivers or other fresh water bodies where water quality does not meet (or is not expected to meet) water quality standards even after the application of appropriate limitations for point sources (40 CFR 130, et seq.)*.” The Basin Plan also states, “*Additional treatment beyond minimum federal standards will be imposed on dischargers to WQLSs. Dischargers will be assigned or allocated a maximum allowable load of critical pollutants so that water quality objectives can be met in the segment.*” Clear Creek is listed as a WQLS for mercury in the 303(d) list of impaired water bodies. The Sacramento River from Keswick Dam to Cottonwood Creek is listed as a WQLS for unknown toxicity in the 303(d) list of impaired water bodies.

Requirements of this Order implement the Basin Plan.

- I. **National Toxics Rule (NTR) and California Toxics Rule (CTR).** USEPA adopted the NTR on 22 December 1992, and later amended it on 4 May 1995 and 9 November 1999. About 40 criteria in the NTR applied in California. On 18 May 2000, USEPA adopted the CTR. The CTR promulgated new toxics criteria for California and, in addition, incorporated the previously adopted NTR criteria that were applicable in the state. The CTR was amended on 13 February 2001. These rules contain water quality criteria for priority pollutants.

- J. **State Implementation Policy.** On 2 March 2000, the State Water Board adopted the *Policy for Implementation of Toxics Standards for Inland Surface Waters, Enclosed Bays, and Estuaries of California* (State Implementation Policy or SIP). The SIP became effective on 28 April 2000 with respect to the priority pollutant criteria promulgated for California by USEPA through the NTR and to the priority pollutant objectives established by the Central Valley Water Board in the Basin Plan. The SIP became effective on 18 May 2000 with respect to the priority pollutant criteria

promulgated by USEPA through the CTR. The State Water Board adopted amendments to the SIP on 24 February 2005 that became effective on 13 July 2005. The SIP establishes implementation provisions for priority pollutant criteria and objectives and provisions for chronic toxicity control. Requirements of this Order implement the SIP.

K. Compliance Schedules and Interim Requirements – Not Applicable

L. Alaska Rule. On 30 March 2000, USEPA revised its regulation that specifies when new and revised state and tribal water quality standards become effective for CWA purposes. (40 CFR 131.21 and 65 FR 24641 (27 April 2000).) Under the revised regulation (also known as the Alaska rule), new and revised standards submitted to USEPA after 30 May 2000, must be approved by USEPA before being used for CWA purposes. The final rule also provides that standards already in effect and submitted to USEPA by 30 May 2000 may be used for CWA purposes, whether or not approved by USEPA.

M. Stringency of Requirements for Individual Pollutants. This Order contains both technology-based effluent limitations and WQBELs for individual pollutants. The technology-based effluent limitations consist of restrictions on flow and total suspended solids (TSS). The WQBELs consist of restrictions on chlorine residual, dichlorobromomethane, manganese, pH, and settleable solids. This Order’s technology-based pollutant restrictions implement the minimum, applicable federal technology-based requirements.

WQBELs have been scientifically derived to implement water quality objectives that protect beneficial uses. Both the beneficial uses and the water quality objectives have been approved pursuant to federal law and are the applicable federal water quality standards. To the extent that toxic pollutant WQBELs were derived from the CTR, the CTR is the applicable standard pursuant to 40 CFR 131.38. The scientific procedures for calculating the individual WQBELs for priority pollutants are based on the CTR-SIP, which was approved by USEPA on 18 May 2000. All beneficial uses and water quality objectives contained in the Basin Plan were approved under state law and submitted to and approved by USEPA prior to 30 May 2000. Any water quality objectives and beneficial uses submitted to USEPA prior to 30 May 2000, but not approved by USEPA before that date, are nonetheless “*applicable water quality standards for purposes of the [Clean Water] Act*” pursuant to 40 CFR 131.21(c)(1). Collectively, this Order’s restrictions on individual pollutants are no more stringent than required to implement the technology-based requirements of the CWA and the applicable water quality standards for purposes of the CWA.

N. Antidegradation Policy. 40 CFR 131.12 requires that the state water quality standards include an antidegradation policy consistent with the federal policy. The State Water Board established California’s antidegradation policy in State Water Board Resolution No. 68-16. Resolution No. 68-16 incorporates the federal antidegradation policy where the federal policy applies under federal law. Resolution No. 68-16 requires that existing quality of waters be maintained unless degradation is justified based on specific findings. The Central Valley Water Board’s Basin Plan implements, and

TENTATIVE DRAFT

incorporates by reference, both the state and federal antidegradation policies. As discussed in detail in the Fact Sheet, the permitted discharge is consistent with the antidegradation provision of 40 CFR 131.12 and Resolution No. 68-16.

O. Anti-Backsliding Requirements. Sections 303(d)(4) and 402(o)(2) of the CWA and federal regulations at 40 CFR 122.44(l) prohibit backsliding in NPDES permits. These anti-backsliding provisions require effluent limitations in a reissued permit to be as stringent as those in the previous permit, with some exceptions. All effluent limitations in this Order are at least as stringent as the effluent limitations in Order No. R5-2006-0116.

P. Endangered Species Act. This Order does not authorize any act that results in the taking of a threatened or endangered species or any act that is now prohibited, or becomes prohibited in the future, under either the California Endangered Species Act (Fish and Game Code sections 2050 to 2097) or the Federal Endangered Species Act (16 U.S.C.A. sections 1531 to 1544). This Order requires compliance with effluent limits, receiving water limits, and other requirements to protect the beneficial uses of waters of the state. The discharger is responsible for meeting all requirements of the applicable Endangered Species Act.

Q. Monitoring and Reporting. 40 CFR 122.48 requires that all NPDES permits specify requirements for recording and reporting monitoring results. Water Code sections 13267 and 13383 authorize the Central Valley Water Board to require technical and monitoring reports. The Monitoring and Reporting Program establishes monitoring and reporting requirements to implement federal and State requirements. The Monitoring and Reporting Program is provided in Attachment E.

The technical and monitoring reports in this Order are required in accordance with Water Code section 13267, which states the following in subsection (b)(1), *“In conducting an investigation specified in subdivision (a), the regional board may require that any person who has discharged, discharges, or is suspected of having discharged or discharging, or who proposes to discharge waste within its region, or any citizen or domiciliary, or political agency or entity of this state who has discharged, discharges, or is suspected of having discharged or discharging, or who proposes to discharge, waste outside of its region that could affect the quality of waters within its region shall furnish, under penalty of perjury, technical or monitoring program reports which the regional board requires. The burden, including costs, of these reports shall bear a reasonable relationship to the need for the report and the benefits to be obtained from the reports. In requiring those reports, the regional board shall provide the person with a written explanation with regard to the need for the reports, and shall identify the evidence that supports requiring that person to provide the reports.”*

The monitoring reports required by this Order are necessary to determine compliance with this Order. The need for the monitoring reports is discussed in the Fact Sheet.

R. Standard and Special Provisions. Standard Provisions, which apply to all NPDES permits in accordance with 40 CFR 122.41, and additional conditions applicable to specified categories of permits in accordance with 40 CFR 122.42, are provided in

TENTATIVE DRAFT

Attachment D. The discharger must comply with all standard provisions and with those additional conditions that are applicable under 40 CFR 122.42. The Central Valley Water Board has also included in this Order special provisions applicable to the Discharger. Some special provisions require submittal of technical reports. All technical reports are required in accordance with Water Code section 13267. The rationale for the special provisions and need for technical reports required in this Order is provided in the Fact Sheet.

- S. Provisions and Requirements Implementing State Law.** The provisions/requirements in sections V.B, VI.A.2.o, and VI.4.a of this Order are included to implement State law only. These provisions/requirements are not required or authorized under the federal CWA; consequently, violations of these provisions/requirements are not subject to the enforcement remedies that are available for NPDES violations.
- T. Notification of Interested Parties.** The Central Valley Water Board has notified the Discharger and interested agencies and persons of its intent to prescribe WDRs for the discharge and has provided them with an opportunity to submit their written comments and recommendations. Details of notification are provided in the Fact Sheet of this Order.
- U. Consideration of Public Comment.** The Central Valley Water Board, in a public meeting, heard and considered all comments pertaining to the discharge. Details of the Public Hearing are provided in the Fact Sheet.

TENTATIVE DRAFT

THEREFORE, IT IS HEREBY ORDERED, that Order No. R5-2006-0116 is rescinded upon the effective date of this Order except for enforcement purposes, and, in order to meet the provisions contained in division 7 of the Water Code (commencing with section 13000) and regulations adopted thereunder, and the provisions of the federal CWA and regulations and guidelines adopted thereunder, the Discharger shall comply with the requirements in this Order.

III. DISCHARGE PROHIBITIONS

- A.** Discharge of wastewater at a location or in a manner different from that described in the Findings is prohibited.
- B.** The by-pass or overflow of wastes to surface waters is prohibited, except as allowed by Federal Standard Provisions I.G. and I.H. (Attachment D).
- C.** Neither the discharge nor its treatment shall create a nuisance as defined in section 13050 of the Water Code.
- D.** The Discharger shall not allow pollutant-free wastewater to be discharged into the treatment or disposal, system in amounts that significantly diminish the system's capability to comply with this Order. Pollutant-free wastewater means rainfall, groundwater, cooling waters, and condensates that are essentially free of pollutants.

TENTATIVE DRAFT

IV. EFFLUENT LIMITATIONS AND DISCHARGE SPECIFICATIONS

A. Effluent Limitations – Discharge Point No. 001

1. Final Effluent Limitations – Discharge Point No. 001

- a. The Discharger shall maintain compliance with the following effluent limitations at Discharge Point No. 001, with compliance measured at Monitoring Location EFF-001 as described in the Monitoring and Reporting Program:

Table 6. Effluent Limitations

Parameter	Units	Effluent Limitations			
		Average Monthly	Maximum Daily	Instantaneous Minimum	Instantaneous Maximum
Flow	MGD	--	1.5	--	--
Chlorine, Total Residual	Mg/L	0.011 ¹	0.019 ²	--	--
pH	standard units	--	--	6.5	8.5
Settleable Solids	ml/L	0.1	0.2	--	--
Total Suspended Solids	mg/L	30	50	--	--
Dichlorobromomethane	µg/L	0.56	1.2	--	--
Manganese, Total Recoverable	µg/L	50 ³	--	--	--

¹ Applied as a 4-day average effluent limitation.
² Applied as a 1-hour average effluent limitation.
³ Applied as an annual average effluent limitation.

- b. **Acute Whole Effluent Toxicity.** Survival of aquatic organisms in 96-hour bioassays of undiluted waste shall be no less than:

- i. 70%, minimum for any one bioassay; and
- ii. 90%, median for any three consecutive bioassays.

2. Interim Effluent Limitations – Not Applicable

B. Land Discharge Specifications – Not Applicable

C. Reclamation Specifications – Not Applicable

TENTATIVE DRAFT

V. RECEIVING WATER LIMITATIONS

A. Surface Water Limitations

Receiving water limitations are based on water quality objectives contained in the Basin Plan and are a required part of this Order. The discharge shall not cause the following in Clear Creek:

1. **Bacteria.** The fecal coliform concentration, based on a minimum of not less than five samples for any 30-day period, to exceed a geometric mean of 200 MPN/100 mL, nor more than 10 percent of the total number of fecal coliform samples taken during any 30-day period to exceed 400 MPN/100 mL.
2. **Biostimulatory Substances.** Water to contain biostimulatory substances which promote aquatic growths in concentrations that cause nuisance or adversely affect beneficial uses.
3. **Chemical Constituents.** Chemical constituents to be present in concentrations that adversely affect beneficial uses.
4. **Color.** Discoloration that causes nuisance or adversely affects beneficial uses.
5. **Dissolved Oxygen:**
 - a. The monthly median of the mean daily dissolved oxygen concentration to fall below 85 percent of saturation in the main water mass;
 - b. The 95 percentile dissolved oxygen concentration to fall below 75 percent of saturation; nor
 - c. The dissolved oxygen concentration to be reduced below 7.0 mg/L at any time.
6. **Floating Material.** Floating material to be present in amounts that cause nuisance or adversely affect beneficial uses.
7. **Oil and Grease.** Oils, greases, waxes, or other materials to be present in concentrations that cause nuisance, result in a visible film or coating on the surface of the water or on objects in the water, or otherwise adversely affect beneficial uses.
8. **pH.** The pH to be depressed below 6.5 nor raised above 8.5.
9. **Pesticides:**
 - a. Pesticides to be present, individually or in combination, in concentrations that adversely affect beneficial uses;
 - b. Pesticides to be present in bottom sediments or aquatic life in concentrations that adversely affect beneficial uses;

TENTATIVE DRAFT

- c. Total identifiable persistent chlorinated hydrocarbon pesticides to be present in the water column at concentrations detectable within the accuracy of analytical methods approved by USEPA or the Executive Officer;
- d. Pesticide concentrations to exceed those allowable by applicable antidegradation policies (see State Water Board Resolution No. 68-16 and 40 CFR 131.12.);
- e. Pesticide concentrations to exceed the lowest levels technically and economically achievable;
- f. Pesticides to be present in concentration in excess of the maximum contaminant levels set forth in CCR, Title 22, division 4, chapter 15; nor
- g. Thiobencarb to be present in excess of 1.0 µg/L.

10. Radioactivity:

- a. Radionuclides to be present in concentrations that are harmful to human, plant, animal, or aquatic life nor that result in the accumulation of radionuclides in the food web to an extent that presents a hazard to human, plant, animal, or aquatic life.
- b. Radionuclides to be present in excess of the maximum contaminant levels specified in Table 4 (MCL Radioactivity) of section 64443 of Title 22 of the California Code of Regulations.

12. Suspended Sediments. The suspended sediment load and suspended sediment discharge rate of surface waters to be altered in such a manner as to cause nuisance or adversely affect beneficial uses.

13. Settleable Substances. Substances to be present in concentrations that result in the deposition of material that causes nuisance or adversely affects beneficial uses.

14. Suspended Material. Suspended material to be present in concentrations that cause nuisance or adversely affect beneficial uses.

15. Taste and Odors. Taste- or odor-producing substances to be present in concentrations that impart undesirable tastes or odors to fish flesh or other edible products of aquatic origin, or that cause nuisance, or otherwise adversely affect beneficial uses.

16. Temperature. The natural temperature to be increased by more than 5°F. Compliance to be determined based on the difference in temperature at RSW-001 and RSW-002.

17. Toxicity. Toxic substances to be present, individually or in combination, in concentrations that produce detrimental physiological responses in human, plant, animal, or aquatic life.

TENTATIVE DRAFT

18. Turbidity.

- a. Shall not exceed 2 Nephelometric Turbidity Units (NTU) where natural turbidity is less than 1 NTU;
- b. Shall not increase more than 1 NTU where natural turbidity is between 1 and 5 NTUs;
- c. Shall not increase more than 20 percent where natural turbidity is between 5 and 50 NTUs;
- d. Shall not increase more than 10 NTU where natural turbidity is between 50 and 100 NTUs; nor
- e. Shall not increase more than 10 percent where natural turbidity is greater than 100 NTUs.

B. Groundwater Limitations

- 1. The discharge shall not cause the groundwater to exceed water quality objectives, unreasonably affect beneficial uses, or cause a condition of pollution or nuisance.

TENTATIVE DRAFT

VI. PROVISIONS

A. Standard Provisions

1. The Discharger shall comply with all Standard Provisions (federal NPDES standard conditions from 40 CFR Part 122) included in Attachment D of this Order.
2. The Discharger shall comply with the following provisions:
 - a. If the Discharger's wastewater treatment plant is publicly owned or subject to regulation by California Public Utilities Commission, it shall be supervised and operated by persons possessing certificates of appropriate grade according to Title 23, CCR, division 3, chapter 26.
 - b. After notice and opportunity for a hearing, this Order may be terminated or modified for cause, including, but not limited to:
 - i. violation of any term or condition contained in this Order;
 - ii. obtaining this Order by misrepresentation or by failing to disclose fully all relevant facts;
 - iii. a change in any condition that requires either a temporary or permanent reduction or elimination of the authorized discharge; and
 - iv. a material change in the character, location, or volume of discharge.

The causes for modification include:

- *New regulations.* New regulations have been promulgated under section 405(d) of the CWA, or the standards or regulations on which the permit was based have been changed by promulgation of amended standards or regulations or by judicial decision after the permit was issued.
- *Land application plans.* When required by a permit condition to incorporate a land application plan for beneficial reuse of sewage sludge, to revise an existing land application plan, or to add a land application plan.
- *Change in sludge use or disposal practice.* Under 40 CFR 122.62(a)(1), a change in the Discharger's sludge use or disposal practice is a cause for modification of the permit. It is cause for revocation and reissuance if the Discharger requests or agrees.

The Central Valley Water Board may review and revise this Order at any time upon application of any affected person or the Central Valley Water Board's own motion.

- c. If a toxic effluent standard or prohibition (including any scheduled compliance specified in such effluent standard or prohibition) is established under section

TENTATIVE DRAFT

307(a) of the CWA, or amendments thereto, for a toxic pollutant that is present in the discharge authorized herein, and such standard or prohibition is more stringent than any limitation upon such pollutant in this Order, the Central Valley Water Board will revise or modify this Order in accordance with such toxic effluent standard or prohibition.

The Discharger shall comply with effluent standards and prohibitions within the time provided in the regulations that establish those standards or prohibitions, even if this Order has not yet been modified.

- d. This Order shall be modified, or alternately revoked and reissued, to comply with any applicable effluent standard or limitation issued or approved under sections 301(b)(2)(C) and (D), 304(b)(2), and 307(a)(2) of the CWA, if the effluent standard or limitation so issued or approved:
 - i. Contains different conditions or is otherwise more stringent than any effluent limitation in the Order; or
 - ii. Controls any pollutant limited in the Order.

The Order, as modified or reissued under this paragraph, shall also contain any other requirements of the CWA then applicable.

- e. The provisions of this Order are severable. If any provision of this Order is found invalid, the remainder of this Order shall not be affected.
- f. The Discharger shall take all reasonable steps to minimize any adverse effects to waters of the State or users of those waters resulting from any discharge or sludge use or disposal in violation of this Order. Reasonable steps shall include such accelerated or additional monitoring as necessary to determine the nature and impact of the non-complying discharge or sludge use or disposal.
- g. The Discharger shall ensure compliance with any existing or future pretreatment standard promulgated by USEPA under section 307 of the CWA, or amendment thereto, for any discharge to the municipal system.
- h. A copy of this Order shall be maintained at the discharge facility and be available at all times to operating personnel. Key operating personnel shall be familiar with its content.
- i. Safeguard to electric power failure:
 - i. The Discharger shall provide safeguards to assure that, should there be reduction, loss, or failure of electric power, the discharge shall comply with the terms and conditions of this Order.
 - ii. Upon written request by the Central Valley Water Board, the Discharger shall submit a written description of safeguards. Such safeguards may include alternate power sources, standby generators, retention capacity, operating

TENTATIVE DRAFT

procedures, or other means. A description of the safeguards provided shall include an analysis of the frequency, duration, and impact of power failures experienced over the past 5 years on effluent quality and on the capability of the Discharger to comply with the terms and conditions of the Order. The adequacy of the safeguards is subject to the approval of the Central Valley Water Board.

iii. Should the treatment works not include safeguards against reduction, loss, or failure of electric power, or should the Central Valley Water Board not approve the existing safeguards, the Discharger shall, within 90 days of having been advised in writing by the Central Valley Water Board that the existing safeguards are inadequate, provide to the Central Valley Water Board and USEPA a schedule of compliance for providing safeguards such that in the event of reduction, loss, or failure of electric power, the Discharger shall comply with the terms and conditions of this Order. The schedule of compliance shall, upon approval of the Central Valley Water Board, become a condition of this Order.

j. The Discharger, upon written request of the Central Valley Water Board, shall file with the Board a technical report on its preventive (failsafe) and contingency (cleanup) plans for controlling accidental discharges, and for minimizing the effect of such events. This report may be combined with that required under Regional Water Board Standard Provision contained in section VI.A.2.i. of this Order.

The technical report shall:

- i. Identify the possible sources of spills, leaks, untreated waste by-pass, and contaminated drainage. Loading and storage areas, power outage, waste treatment unit outage, and failure of process equipment, tanks and pipes should be considered.
- ii. Evaluate the effectiveness of present facilities and procedures and state when they became operational.
- iii. Predict the effectiveness of the proposed facilities and procedures and provide an implementation schedule containing interim and final dates when they will be constructed, implemented, or operational.

The Central Valley Water Board, after review of the technical report, may establish conditions which it deems necessary to control accidental discharges and to minimize the effects of such events. Such conditions shall be incorporated as part of this Order, upon notice to the Discharger.

k. A publicly owned treatment works whose waste flow has been increasing, or is projected to increase, shall estimate when flows will reach hydraulic and treatment capacities of its treatment and disposal facilities. The projections shall be made in January, based on the last 3 years' average dry weather flows, peak

TENTATIVE DRAFT

wet weather flows and total annual flows, as appropriate. When any projection shows that capacity of any part of the facilities may be exceeded in 4 years, the Discharger shall notify the Central Valley Water Board by 31 January. A copy of the notification shall be sent to appropriate local elected officials, local permitting agencies and the press. Within 120 days of the notification, the Discharger shall submit a technical report showing how it will prevent flow volumes from exceeding capacity or how it will increase capacity to handle the larger flows. The Central Valley Water Board may extend the time for submitting the report.

- i.** The Discharger shall submit technical reports as directed by the Executive Officer. All technical reports required herein that involve planning, investigation, evaluation, or design, or other work requiring interpretation and proper application of engineering or geologic sciences, shall be prepared by or under the direction of persons registered to practice in California pursuant to California Business and Professions Code, sections 6735, 7835, and 7835.1. To demonstrate compliance with Title 16, CCR, sections 415 and 3065, all technical reports must contain a statement of the qualifications of the responsible registered professional(s). As required by these laws, completed technical reports must bear the signature(s) and seal(s) of the registered professional(s) in a manner such that all work can be clearly attributed to the professional responsible for the work.
- m.** The Central Valley Water Board is authorized to enforce the terms of this permit under several provisions of the Water Code, including, but not limited to, sections 13385, 13386, and 13387.
- n.** For publicly owned treatment works, prior to making any change in the point of discharge, place of use, or purpose of use of treated wastewater that results in a permanent decrease of flow in any portion of a watercourse, the Discharger must file a petition with the State Water Board, Division of Water Rights, and receive approval for such a change. (Water Code section 1211).
- o.** In the event the Discharger does not comply or will be unable to comply for any reason, with any prohibition, maximum daily effluent limitation, 1-hour average effluent limitation, or receiving water limitation contained in this Order, the Discharger shall notify the Central Valley Water Board by telephone (530) 224-4845 within 24 hours of having knowledge of such noncompliance, and shall confirm this notification in writing within 5 days, unless the Central Valley Water Board waives confirmation. The written notification shall include the information required by the Standard Provision contained in Attachment D section V.E.1. [40 CFR 122.41(l)(6)(i)].
- p.** Failure to comply with provisions or requirements of this Order, or violation of other applicable laws or regulations governing discharges from this facility, may subject the Discharger to administrative or civil liabilities, criminal penalties, and/or other enforcement remedies to ensure compliance. Additionally, certain violations may subject the Discharger to civil or criminal enforcement from appropriate local, state, or federal law enforcement entities.

TENTATIVE DRAFT

- q. In the event of any change in control or ownership of land or waste discharge facilities presently owned or controlled by the Discharger, the Discharger shall notify the succeeding owner or operator of the existence of this Order by letter, a copy of which shall be immediately forwarded to the Central Valley Water Board.

To assume operation under this Order, the succeeding owner or operator must apply in writing to the Executive Officer requesting transfer of the Order. The request must contain the requesting entity's full legal name, the state of incorporation if a corporation, address and telephone number of the persons responsible for contact with the Central Valley Water Board and a statement. The statement shall comply with the signatory and certification requirements in the federal Standard Provisions (Attachment D, section V.B) and state that the new owner or operator assumes full responsibility for compliance with this Order. Failure to submit the request shall be considered a discharge without requirements, a violation of the Water Code. Transfer shall be approved or disapproved in writing by the Executive Officer.

B. Monitoring and Reporting Program Requirements

The Discharger shall comply with the Monitoring and Reporting Program, and future revisions thereto, in Attachment E of this Order.

C. Special Provisions

1. Reopener Provisions

- a. Conditions that necessitate a major modification of a permit are described in 40 CFR 122.62, including, but not limited to:
 - i. If new or amended applicable water quality standards are promulgated or approved pursuant to section 303 of the CWA, or amendments thereto, this permit may be reopened and modified in accordance with the new or amended standards.
 - ii. When new information, that was not available at the time of permit issuance, would have justified different permit conditions at the time of issuance.
- b. This Order may be reopened for modification, or revocation and reissuance, as a result of the detection of a reportable priority pollutant generated by special conditions included in this Order. These special conditions may be, but are not limited to, fish tissue sampling, whole effluent toxicity, monitoring requirements on internal waste stream(s), and monitoring for surrogate parameters. Additional requirements may be included in this Order as a result of the special condition monitoring data.
- c. **Mercury.** If mercury is found to be causing toxicity based on acute or chronic toxicity test results, or if a TMDL program is adopted, this Order shall be reopened and an effluent mass or concentration limitation imposed. If the

TENTATIVE DRAFT

Central Valley Water Board determines that a mercury offset program is feasible for Dischargers subject to a NPDES permit, then this Order may be reopened to reevaluate mercury mass loading limitation(s) and the need for a mercury offset program for the Discharger.

- d. **Whole Effluent Toxicity.** As a result of a Toxicity Reduction Evaluation (TRE), this Order may be reopened to include a chronic toxicity limitation, a new acute toxicity limitation, and/or a limitation for a specific toxicant identified in the TRE. Additionally, if the State Water Board revises the SIP's toxicity control provisions that would require the establishment of numeric chronic toxicity effluent limitations, this Order may be reopened to include a numeric chronic toxicity effluent limitation based on the new provisions.
- e. **Water Effects Ratios (WER) and Metal Translators.** A default WER of 1.0 has been used in this Order for calculating criteria for applicable inorganic constituents. In addition, default dissolved-to-total metal translators may be used to convert water quality objectives from dissolved to total recoverable when developing effluent limitations for copper if additional monitoring indicates that effluent limitations are necessary. If the Discharger performs studies to determine site-specific WERs and/or site-specific dissolved-to-total metal translators, this Order may be reopened to modify the effluent limitations for the applicable inorganic constituents.
- f. **Constituent Study.** If after review of the study results it is determined that the discharge has reasonable potential to cause or contribute to an exceedance of a water quality objective this Order may be reopened and effluent limitations added for the subject constituents.

2. Special Studies, Technical Reports and Additional Monitoring Requirements

- a. **Chronic Whole Effluent Toxicity.** For compliance with the Basin Plan's narrative toxicity objective, this Order requires the Discharger to conduct chronic whole effluent toxicity (WET) testing, as specified in the Monitoring and Reporting Program (Attachment E, section V). Furthermore, this Provision requires the Discharger to investigate the causes of, and identify corrective actions to reduce or eliminate effluent toxicity. If the discharge exhibits toxicity, as described in subsection ii below, the Discharger is required to initiate a TRE in accordance with an approved TRE Workplan, and take actions to mitigate the impact of the discharge and prevent recurrence of toxicity. A TRE is a site-specific study conducted in a stepwise process to identify the source(s) of toxicity and the effective control measures for effluent toxicity. TREs are designed to identify the causative agents and sources of effluent toxicity, evaluate the effectiveness of the toxicity control options, and confirm the reduction in effluent toxicity. This Provision includes requirements for the Discharger to develop and submit a TRE Workplan and includes procedures for accelerated chronic toxicity monitoring and TRE initiation.

TENTATIVE DRAFT

- i. Initial Investigative TRE Workplan.** Within 90 days of the effective date of this Order, the Discharger shall submit to the Central Valley Water Board an Initial Investigative TRE Workplan for approval by the Executive Officer. This should be a one to two page document including, at a minimum:

 - (a)** A description of the investigation and evaluation techniques that will be used to identify potential causes and sources of effluent toxicity, effluent variability, and treatment system efficiency;
 - (b)** A description of the facility's methods of maximizing in-house treatment efficiency and good housekeeping practices, and a list of all chemicals used in operation of the facility; and
 - (c)** A discussion of who will conduct the Toxicity Identification Evaluation (TIE), if necessary (e.g., an in-house expert or outside contractor).
- ii. Accelerated Monitoring and TRE Initiation.** When the numeric toxicity monitoring trigger is exceeded during regular chronic toxicity monitoring, the Discharger shall initiate accelerated monitoring as required in the Accelerated Monitoring Specifications. The Discharger shall initiate a TRE to address effluent toxicity if any WET testing results exceed the numeric toxicity monitoring trigger during accelerated monitoring.
- iii. Numeric Toxicity Monitoring Trigger.** The numeric toxicity monitoring trigger to initiate a TRE is $> 1 TU_c$ (where $TU_c = 100/NOEC$). The monitoring trigger is not an effluent limitation; it is the toxicity threshold at which the Discharger is required to begin accelerated monitoring and initiate a TRE when the effluent exhibits toxicity.
- iv. Accelerated Monitoring Specifications.** If the numeric toxicity monitoring trigger is exceeded during regular chronic toxicity testing, the Discharger shall initiate accelerated monitoring within 14 days of notification by the laboratory of the exceedance. Accelerated monitoring shall consist of four (4) chronic toxicity tests conducted once every 2 weeks using the species that exhibited toxicity. The following protocol shall be used for accelerated monitoring and TRE initiation:

 - (a)** If the results of four (4) consecutive accelerated monitoring tests do not exceed the monitoring trigger, the Discharger may cease accelerated monitoring and resume regular chronic toxicity monitoring. However, notwithstanding the accelerated monitoring results, if there is evidence of effluent toxicity, the Executive Officer may require that the Discharger initiate a TRE.
 - (b)** If the source(s) of the toxicity is easily identified (e.g., temporary plant upset), the Discharger shall make necessary corrections to the facility and shall continue accelerated monitoring until four (4) consecutive accelerated tests do not exceed the monitoring trigger. Upon confirmation

that the effluent toxicity has been removed, the Discharger may cease accelerated monitoring and resume regular chronic toxicity monitoring.

(c) If the result of any accelerated toxicity test exceeds the monitoring trigger, the Discharger shall cease accelerated monitoring and begin a TRE to investigate the cause(s) of, and identify corrective actions to reduce or eliminate effluent toxicity. Within thirty (30) days of notification by the laboratory of any test result exceeding the monitoring trigger during accelerated monitoring, the Discharger shall submit a TRE Action Plan to the Central Valley Water Board including, at minimum:

- (1) Specific actions the Discharger will take to investigate and identify the cause(s) of toxicity, including a TRE WET monitoring schedule;
- (2) Specific actions the Discharger will take to mitigate the impact of the discharge and prevent the recurrence of toxicity; and
- (3) A schedule for these actions.

Within sixty (60) days of notification by the laboratory of the test results, the Discharger shall submit to the Central Valley Water Board a TRE Workplan for approval by the Executive Officer. The TRE Workplan shall outline the procedures for identifying the source(s) of, and reducing or eliminating effluent toxicity. The TRE Workplan must be developed in accordance with USEPA guidance¹.

- b. Constituent Study.** There are indications that the discharge may contain constituents that have a reasonable potential to cause or contribute to an exceedance of water quality objectives, including bis (2-ethylhexyl) phthalate and copper. The Discharger shall conduct monitoring for bis (2-ethylhexyl) phthalate and copper quarterly for 3 years as outlined in Attachment E and submit a study report evaluating the results of the monitoring with 6 months following completion of the final monitoring event during the fourth year of the permit term.
- c. Aluminum Study.** This Order requires the Discharger to conduct monitoring for aluminum as outlined in the Monitoring and Reporting Program (Attachment E). After review of the study results the Central Valley Water board will evaluate the recommendations, reevaluate reasonable potential for aluminum, and reopen the permit, if necessary, to include effluent limitations for aluminum.
- d. Effluent and Receiving Water Characterization Study.** An effluent and receiving water monitoring study is required to ensure adequate information is available for the next permit renewal. The Discharger shall conduct monitoring of the effluent at Monitoring Location EFF-001 and of the receiving water at Monitoring Location RSW-001 for all priority pollutants and other constituents of concern as described in Attachment I. Where this monitoring duplicates the

¹ See the Fact Sheet (Attachment F, section VII.B.2.a) for a list of USEPA guidance documents that must be considered in development of the TRE Workplan.

locations and frequencies of monitoring otherwise required in the Monitoring and Reporting Program (Attachment E), duplicate monitoring is not required.

3. Best Management Practices and Pollution Prevention – Not Applicable

4. Construction, Operation and Maintenance Specifications

a. Treatment Pond Operating Requirements

- i. The treatment facilities shall be designed, constructed, operated, and maintained to prevent inundation or washout due to floods with a 100-year return frequency.
- ii. Public contact with wastewater shall be precluded through such means as fences, signs, and other acceptable alternatives.
- iii. Ponds shall be managed to prevent breeding of mosquitoes. In particular,
 - (a) An erosion control program should assure that small coves and irregularities are not created around the perimeter of the water surface.
 - (b) Weeds shall be minimized.
 - (c) Dead algae, vegetation, and debris shall not accumulate on the water surface.
- iv. Freeboard shall never be less than 2 feet (measured vertically to the lowest point of overflow, except if lesser freeboard does not threaten the integrity of the ponds, no overflow of the ponds occurs, and lesser freeboard is due to direct precipitation or storm water runoff occurring as a result of annual precipitation with greater than a 100-year recurrence interval, or a storm event with an intensity greater than a 25-year, 24-hour storm event.
- v. The discharge of waste classified as “hazardous” as defined in section 2521(a) of Title 23, California Code of Regulations (CCR), or “designated”, as defined in section 13173 of the Water Code, to the treatment ponds is prohibited.
- vi. Objectionable odors originating at this Facility shall not be perceivable beyond the limits of the wastewater treatment and disposal areas (or property owned by the Discharger).
- vii. As a means of discerning compliance with Treatment Pond Operating Requirement VI.C.4.a.vi, the dissolved oxygen content in the upper zone (1 foot) of wastewater in ponds shall not be less than 1.0 mg/L.
- viii. Ponds shall not have a pH less than 6.5 or greater than 8.5.

TENTATIVE DRAFT

5. Special Provisions for Municipal Facilities (POTWs Only) – Not Applicable

6. Other Special Provisions

a. Sludge Disposal Requirements

- i. Collected screenings, residual sludge, and other solids removed from liquid wastes, including pond sediments, shall be disposed of in a manner approved by the Executive officer and consistent with the Consolidated Regulations for Treatment, Storage, Processing, or Disposal of Solid Waste, as set forth in Title 27, California Code of Regulations (CCR), Division 2, Subdivision 1, Section 20005, et seq. Removal for further treatment, disposal, or reuse at sites (e.g., landfill, composting sites, soil amendment sites) that are operated in accordance with valid waste discharge requirements issued by the Regional Water Board will satisfy these specifications.
- ii. Any proposed change in pond sludge disposal or storage practice shall be reported to the Executive Officer at least 90 days in advance of the change.

b. Low Threat Discharges. On 12 June 2008, the Central Valley Water Board adopted Order No. R5-2008-0081, *Waste Discharge Requirements for Dewatering and Other Low Threat Discharges*. The Discharger shall be subject to the requirements of R5-2008-0081 and any future revisions thereto. Order No. R5-2008-0081 applies to individuals, public agencies, private businesses, and other legal entities discharging relatively pollutant-free wastewaters that pose little or no threat to the quality of surface waters, for a duration of either 4 months or less in duration or have an average dry weather flow less than 0.25 MGD. The Discharger shall submit a Notice of Applicability (NOA) for coverage under Order No. R5-2008-0081 prior to discharging low threat wastewater.

7. Compliance Schedules – Not Applicable

TENTATIVE DRAFT

VII. COMPLIANCE DETERMINATION

- A. Total Residual Chlorine Effluent Limitations (Section IV.A.1.a).** Compliance with the final effluent limitations for total chlorine residual required in Limitations and Discharge Requirements section IV.A.1.a shall be ascertained by daily grab samples prior to and during discharge to the surface waters. Any excursion above the 1-hour or 4-day average total residual chlorine effluent limitation is a violation. If the Discharger conducts continuous monitoring and the Discharger can demonstrate, through data collected from a back-up monitoring system, that a chlorine spike recorded by the continuous monitor was not actually due to chlorine, then any excursion resulting from the recorded spike will not be considered an exceedance, but rather reported as a false positive. Records supporting validation of false positives shall be maintained in accordance with Section IV Standard Provisions (Attachment D).
- B. Priority Pollutant Effluent Limitations.** Compliance with effluent limitations for priority pollutants shall be determined using sample reporting protocols defined in Attachment A and Attachment E of this Order. For purposes of reporting and administrative enforcement by the Central Valley Water Board and the State Water Board, the Discharger shall be deemed out of compliance with effluent limitations if the concentration of the priority pollutant in the monitoring sample is greater than the effluent limitation and greater than or equal to the reporting level (RL).

TENTATIVE DRAFT

ATTACHMENT A – DEFINITIONS

Arithmetic Mean (μ)

Also called the average, is the sum of measured values divided by the number of samples. For ambient water concentrations, the arithmetic mean is calculated as follows:

Arithmetic mean = $\mu = \Sigma x / n$ where: Σx is the sum of the measured ambient water concentrations, and n is the number of samples.

Average Monthly Effluent Limitation (AMEL)

The highest allowable average of daily discharges over a calendar month, calculated as the sum of all daily discharges measured during a calendar month divided by the number of daily discharges measured during that month.

Average Weekly Effluent Limitation (AWEL)

The highest allowable average of daily discharges over a calendar week (Sunday through Saturday), calculated as the sum of all daily discharges measured during a calendar week divided by the number of daily discharges measured during that week.

Bioaccumulative

Those substances taken up by an organism from its surrounding medium through gill membranes, epithelial tissue, or from food and subsequently concentrated and retained in the body of the organism.

Carcinogenic

Pollutants are substances that are known to cause cancer in living organisms.

Coefficient of Variation (CV)

CV is a measure of the data variability and is calculated as the estimated standard deviation divided by the arithmetic mean of the observed values.

Daily Discharge

Daily Discharge is defined as either: (1) the total mass of the constituent discharged over the calendar day (12:00 am through 11:59 pm) or any 24-hour period that reasonably represents a calendar day for purposes of sampling (as specified in the permit), for a constituent with limitations expressed in units of mass or; (2) the unweighted arithmetic mean measurement of the constituent over the day for a constituent with limitations expressed in other units of measurement (e.g., concentration).

The daily discharge may be determined by the analytical results of a composite sample taken over the course of 1 day (a calendar day or other 24-hour period defined as a day) or by the arithmetic mean of analytical results from one or more grab samples taken over the course of the day.

For composite sampling, if 1 day is defined as a 24-hour period other than a calendar day, the analytical result for the 24-hour period will be considered as the result for the calendar day in which the 24-hour period ends.

TENTATIVE DRAFT

Detected, but Not Quantified (DNQ)

DNQ are those sample results less than the RL, but greater than or equal to the laboratory's MDL.

Dilution Credit

Dilution Credit is the amount of dilution granted to a discharge in the calculation of a water quality-based effluent limitation, based on the allowance of a specified mixing zone. It is calculated from the dilution ratio or determined through conducting a mixing zone study or modeling of the discharge and receiving water.

Effluent Concentration Allowance (ECA)

ECA is a value derived from the water quality criterion/objective, dilution credit, and ambient background concentration that is used, in conjunction with the coefficient of variation for the effluent monitoring data, to calculate a long-term average (LTA) discharge concentration. The ECA has the same meaning as waste load allocation (WLA) as used in USEPA guidance (Technical Support Document For Water Quality-based Toxics Control, March 1991, second printing, EPA/505/2-90-001).

Enclosed Bays

Enclosed Bays means indentations along the coast that enclose an area of oceanic water within distinct headlands or harbor works. Enclosed bays include all bays where the narrowest distance between the headlands or outermost harbor works is less than 75 percent of the greatest dimension of the enclosed portion of the bay. Enclosed bays include, but are not limited to, Humboldt Bay, Bodega Harbor, Tomales Bay, Drake's Estero, San Francisco Bay, Morro Bay, Los Angeles-Long Beach Harbor, Upper and Lower Newport Bay, Mission Bay, and San Diego Bay. Enclosed bays do not include inland surface waters or ocean waters.

Estimated Chemical Concentration

The estimated chemical concentration that results from the confirmed detection of the substance by the analytical method below the ML value.

Estuaries

Estuaries means waters, including coastal lagoons, located at the mouths of streams that serve as areas of mixing for fresh and ocean waters. Coastal lagoons and mouths of streams that are temporarily separated from the ocean by sandbars shall be considered estuaries. Estuarine waters shall be considered to extend from a bay or the open ocean to a point upstream where there is no significant mixing of fresh water and seawater. Estuarine waters included, but are not limited to, the Sacramento-San Joaquin Delta, as defined in Water Code section 12220, Suisun Bay, Carquinez Strait downstream to the Carquinez Bridge, and appropriate areas of the Smith, Mad, Eel, Noyo, Russian, Klamath, San Diego, and Otay rivers. Estuaries do not include inland surface waters or ocean waters.

Inland Surface Waters

All surface waters of the State that do not include the ocean, enclosed bays, or estuaries.

Instantaneous Maximum Effluent Limitation

The highest allowable value for any single grab sample or aliquot (i.e., each grab sample or aliquot is independently compared to the instantaneous maximum limitation).

TENTATIVE DRAFT

Instantaneous Minimum Effluent Limitation

The lowest allowable value for any single grab sample or aliquot (i.e., each grab sample or aliquot is independently compared to the instantaneous minimum limitation).

Maximum Daily Effluent Limitation (MDEL)

The highest allowable daily discharge of a pollutant, over a calendar day (or 24-hour period). For pollutants with limitations expressed in units of mass, the daily discharge is calculated as the total mass of the pollutant discharged over the day. For pollutants with limitations expressed in other units of measurement, the daily discharge is calculated as the arithmetic mean measurement of the pollutant over the day.

Median

The middle measurement in a set of data. The median of a set of data is found by first arranging the measurements in order of magnitude (either increasing or decreasing order). If the number of measurements (n) is odd, then the median = $X_{(n+1)/2}$. If n is even, then the median = $(X_{n/2} + X_{(n/2)+1})/2$ (i.e., the midpoint between the $n/2$ and $n/2+1$).

Method Detection Limit (MDL)

MDL is the minimum concentration of a substance that can be measured and reported with 99 percent confidence that the analyte concentration is greater than zero, as defined in 40 CFR Part 136, Attachment B, revised as of 3 July 1999.

Minimum Level (ML)

ML is the concentration at which the entire analytical system must give a recognizable signal and acceptable calibration point. The ML is the concentration in a sample that is equivalent to the concentration of the lowest calibration standard analyzed by a specific analytical procedure, assuming that all the method specified sample weights, volumes, and processing steps have been followed.

Mixing Zone

Mixing Zone is a limited volume of receiving water that is allocated for mixing with a wastewater discharge where water quality criteria can be exceeded without causing adverse effects to the overall water body.

Not Detected (ND)

Sample results which are less than the laboratory's MDL.

Ocean Waters

The territorial marine waters of the State as defined by California law to the extent these waters are outside of enclosed bays, estuaries, and coastal lagoons. Discharges to ocean waters are regulated in accordance with the State Water Board's California Ocean Plan.

Persistent Pollutants

Persistent pollutants are substances for which degradation or decomposition in the environment is nonexistent or very slow.

TENTATIVE DRAFT

Pollutant Minimization Program (PMP)

PMP means waste minimization and pollution prevention actions that include, but are not limited to, product substitution, waste stream recycling, alternative waste management methods, and education of the public and businesses. The goal of the PMP shall be to reduce all potential sources of a priority pollutant(s) through pollutant minimization (control) strategies, including pollution prevention measures as appropriate, to maintain the effluent concentration at or below the water quality-based effluent limitation. Pollution prevention measures may be particularly appropriate for persistent bioaccumulative priority pollutants where there is evidence that beneficial uses are being impacted. The Central Valley Water Board may consider cost effectiveness when establishing the requirements of a PMP. The completion and implementation of a Pollution Prevention Plan, if required pursuant to Water Code section 13263.3(d), shall be considered to fulfill the PMP requirements.

Pollution Prevention

Pollution Prevention means any action that causes a net reduction in the use or generation of a hazardous substance or other pollutant that is discharged into water and includes, but is not limited to, input change, operational improvement, production process change, and product reformulation (as defined in Water Code section 13263.3). Pollution prevention does not include actions that merely shift a pollutant in wastewater from one environmental medium to another environmental medium, unless clear environmental benefits of such an approach are identified to the satisfaction of the State or Regional Water Board.

Reporting Level (RL)

RL is the ML (and its associated analytical method) chosen by the Discharger for reporting and compliance determination from the MLs included in this Order. The MLs included in this Order correspond to approved analytical methods for reporting a sample result that are selected by the Central Valley Water Board either from Appendix 4 of the SIP in accordance with section 2.4.2 of the SIP or established in accordance with section 2.4.3 of the SIP. The ML is based on the proper application of method-based analytical procedures for sample preparation and the absence of any matrix interferences. Other factors may be applied to the ML depending on the specific sample preparation steps employed. For example, the treatment typically applied in cases where there are matrix-effects is to dilute the sample or sample aliquot by a factor of ten. In such cases, this additional factor must be applied to the ML in the computation of the RL.

Satellite Collection System

The portion, if any, of a sanitary sewer system owned or operated by a different public agency than the agency that owns and operates the wastewater treatment facility that a sanitary sewer system is tributary to.

Source of Drinking Water

Any water designated as municipal or domestic supply (MUN) in a Regional Water Board Basin Plan.

TENTATIVE DRAFT

Standard Deviation (σ)

Standard Deviation is a measure of variability that is calculated as follows:

$$\sigma = (\sum[(x - \mu)^2]/(n - 1))^{0.5}$$

where:

x is the observed value;

μ is the arithmetic mean of the observed values; and

n is the number of samples.

Toxicity Reduction Evaluation (TRE)

TRE is a study conducted in a step-wise process designed to identify the causative agents of effluent or ambient toxicity, isolate the sources of toxicity, evaluate the effectiveness of toxicity control options, and then confirm the reduction in toxicity. The first steps of the TRE consist of the collection of data relevant to the toxicity, including additional toxicity testing, and an evaluation of facility operations and maintenance practices, and best management practices. A Toxicity Identification Evaluation (TIE) may be required as part of the TRE, if appropriate. (A TIE is a set of procedures to identify the specific chemical(s) responsible for toxicity. These procedures are performed in three phases (characterization, identification, and confirmation) using aquatic organism toxicity tests.)

TENTATIVE DRAFT

ATTACHMENT B – MAPS

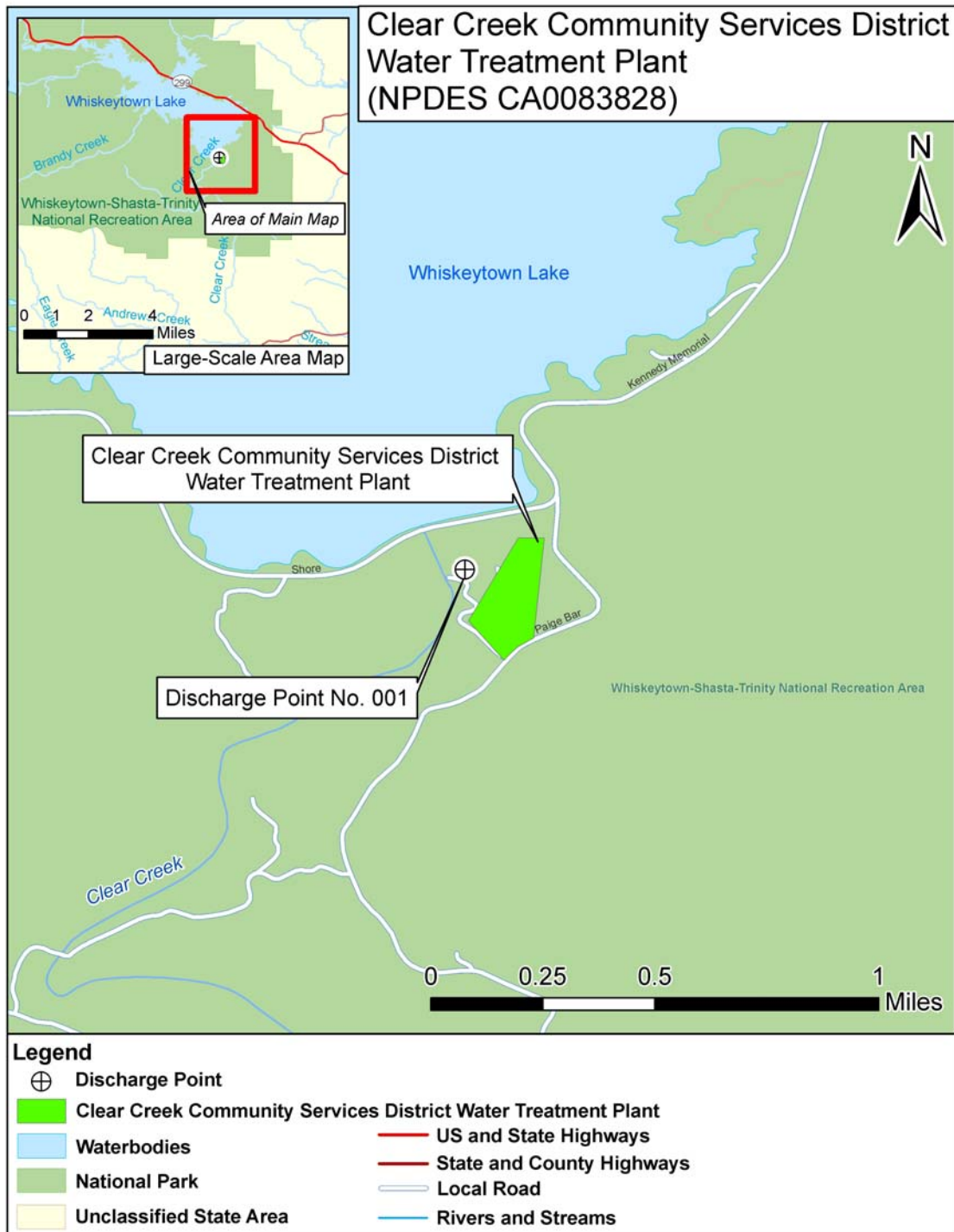

TENTATIVE DRAFT

SITE LOCATION MAP

CLEAR CREEK COMMUNITY SERVICES DISTRICT
 CLEAR CREEK COMMUNITY SERVICES DISTRICT WATER TREATMENT PLANT
 SHASTA COUNTY

ATTACHMENT C – FLOW SCHEMATIC

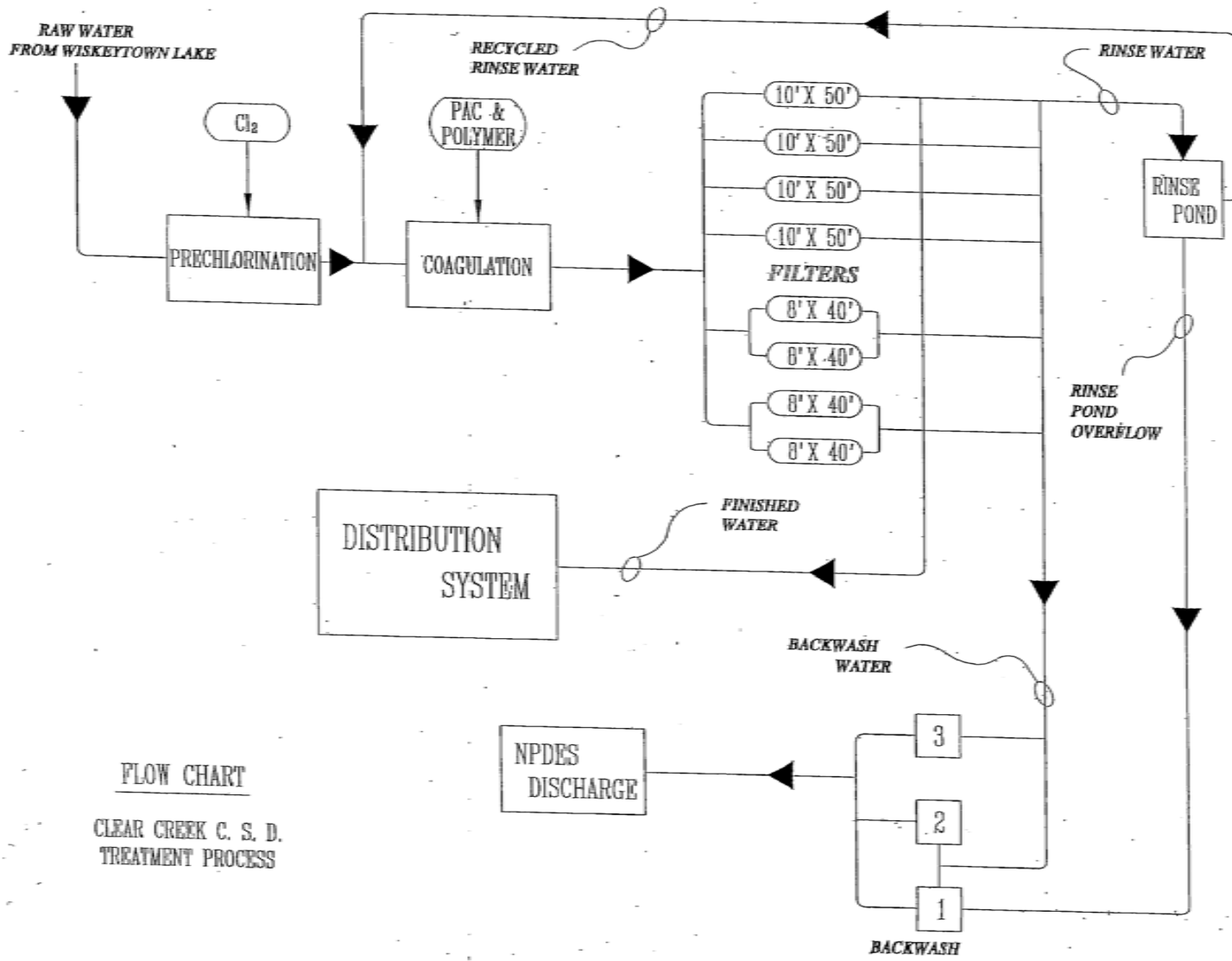

FLOW CHART
CLEAR CREEK C. S. D.
TREATMENT PROCESS

TENTATIVE DRAFT

ATTACHMENT D – STANDARD PROVISIONS

I. STANDARD PROVISIONS – PERMIT COMPLIANCE

A. Duty to Comply

1. The Discharger must comply with all of the conditions of this Order. Any noncompliance constitutes a violation of the Clean Water Act (CWA) and the California Water Code (Water Code) and is grounds for enforcement action, for permit termination, revocation and reissuance, or modification; or denial of a permit renewal application. (40 CFR 122.41(a).)
2. The Discharger shall comply with effluent standards or prohibitions established under section 307(a) of the CWA for toxic pollutants and with standards for sewage sludge use or disposal established under section 405(d) of the CWA within the time provided in the regulations that establish these standards or prohibitions, even if this Order has not yet been modified to incorporate the requirement. (40 CFR 122.41(a)(1).)

B. Need to Halt or Reduce Activity Not a Defense

It shall not be a defense for a Discharger in an enforcement action that it would have been necessary to halt or reduce the permitted activity in order to maintain compliance with the conditions of this Order. (40 CFR 122.41(c))

C. Duty to Mitigate

The Discharger shall take all reasonable steps to minimize or prevent any discharge or sludge use or disposal in violation of this Order that has a reasonable likelihood of adversely affecting human health or the environment. (40 CFR 122.41(d))

D. Proper Operation and Maintenance

The Discharger shall at all times properly operate and maintain all facilities and systems of treatment and control (and related appurtenances) which are installed or used by the Discharger to achieve compliance with the conditions of this Order. Proper operation and maintenance also includes adequate laboratory controls and appropriate quality assurance procedures. This provision requires the operation of backup or auxiliary facilities or similar systems that are installed by a Discharger only when necessary to achieve compliance with the conditions of this Order. (40 CFR 122.41(e).)

E. Property Rights

1. This Order does not convey any property rights of any sort or any exclusive privileges. (40 CFR 122.41(g))

**T
E
N
T
A
T
I
V
E
D
R
A
F
T**

2. The issuance of this Order does not authorize any injury to persons or property or invasion of other private rights, or any infringement of state or local law or regulations. (40 CFR 122.5(c))

F. Inspection and Entry

The Discharger shall allow the Regional Water Board, State Water Board, United States Environmental Protection Agency (USEPA), and/or their authorized representatives (including an authorized contractor acting as their representative), upon the presentation of credentials and other documents, as may be required by law, to (40 CFR 122.41(i); Water Code section 13383):

1. Enter upon the Discharger's premises where a regulated facility or activity is located or conducted, or where records are kept under the conditions of this Order (40 CFR 122.41(i)(1));
2. Have access to and copy, at reasonable times, any records that must be kept under the conditions of this Order (40 CFR 122.41(i)(2));
3. Inspect and photograph, at reasonable times, any facilities, equipment (including monitoring and control equipment), practices, or operations regulated or required under this Order (40 CFR 122.41(i)(3)); and
4. Sample or monitor, at reasonable times, for the purposes of assuring Order compliance or as otherwise authorized by the CWA or the Water Code, any substances or parameters at any location. (40 CFR 122.41(i)(4))

G. Bypass

1. Definitions
 - a. "Bypass" means the intentional diversion of waste streams from any portion of a treatment facility. (40 CFR 122.41(m)(1)(i))
 - b. "Severe property damage" means substantial physical damage to property, damage to the treatment facilities, which causes them to become inoperable, or substantial and permanent loss of natural resources that can reasonably be expected to occur in the absence of a bypass. Severe property damage does not mean economic loss caused by delays in production. (40 CFR 122.41(m)(1)(ii))
2. Bypass not exceeding limitations. The Discharger may allow any bypass to occur which does not cause exceedances of effluent limitations, but only if it is for essential maintenance to assure efficient operation. These bypasses are not subject to the provisions listed in Standard Provisions – Permit Compliance I.G.3, I.G.4, and I.G.5 below. (40 CFR 122.41(m)(2))

**T
E
N
T
A
T
I
V
E
D
R
A
F
T**

TENTATIVE DRAFT

3. Prohibition of bypass. Bypass is prohibited, and the Regional Water Board may take enforcement action against a Discharger for bypass, unless (40 CFR 122.41(m)(4)(i)):
 - a. Bypass was unavoidable to prevent loss of life, personal injury, or severe property damage (40 CFR 122.41(m)(4)(i)(A));
 - b. There were no feasible alternatives to the bypass, such as the use of auxiliary treatment facilities, retention of untreated wastes, or maintenance during normal periods of equipment downtime. This condition is not satisfied if adequate back-up equipment should have been installed in the exercise of reasonable engineering judgment to prevent a bypass that occurred during normal periods of equipment downtime or preventive maintenance (40 CFR 122.41(m)(4)(i)(B)); and
 - c. The Discharger submitted notice to the Regional Water Board as required under Standard Provisions – Permit Compliance I.G.5 below. (40 CFR 122.41(m)(4)(i)(C))
4. The Regional Water Board may approve an anticipated bypass, after considering its adverse effects, if the Regional Water Board determines that it will meet the three conditions listed in Standard Provisions – Permit Compliance I.G.3 above. (40 CFR 122.41(m)(4)(ii))
5. Notice
 - a. Anticipated bypass. If the Discharger knows in advance of the need for a bypass, it shall submit a notice, if possible at least 10 days before the date of the bypass. (40 CFR 122.41(m)(3)(i))
 - b. Unanticipated bypass. The Discharger shall submit notice of an unanticipated bypass as required in Standard Provisions - Reporting V.E below (24-hour notice). (40 CFR 122.41(m)(3)(ii))

H. Upset

Upset means an exceptional incident in which there is unintentional and temporary noncompliance with technology based permit effluent limitations because of factors beyond the reasonable control of the Discharger. An upset does not include noncompliance to the extent caused by operational error, improperly designed treatment facilities, inadequate treatment facilities, lack of preventive maintenance, or careless or improper operation. (40 CFR 122.41(n)(1))

1. Effect of an upset. An upset constitutes an affirmative defense to an action brought for noncompliance with such technology based permit effluent limitations if the requirements of Standard Provisions – Permit Compliance I.H.2 below are met. No determination made during administrative review of claims that noncompliance was

caused by upset, and before an action for noncompliance, is final administrative action subject to judicial review. (40 CFR 122.41(n)(2))

2. Conditions necessary for a demonstration of upset. A Discharger who wishes to establish the affirmative defense of upset shall demonstrate, through properly signed, contemporaneous operating logs or other relevant evidence that (40 CFR 122.41(n)(3)):
 - a. An upset occurred and that the Discharger can identify the cause(s) of the upset (40 CFR 122.41(n)(3)(i));
 - b. The permitted facility was, at the time, being properly operated (40 CFR 122.41(n)(3)(ii));
 - c. The Discharger submitted notice of the upset as required in Standard Provisions – Reporting V.E.2.b below (24-hour notice) (40 CFR 122.41(n)(3)(iii)); and
 - d. The Discharger complied with any remedial measures required under Standard Provisions – Permit Compliance I.C above. (40 CFR 122.41(n)(3)(iv))
3. Burden of proof. In any enforcement proceeding, the Discharger seeking to establish the occurrence of an upset has the burden of proof. (40 CFR 122.41(n)(4))

II. STANDARD PROVISIONS – PERMIT ACTION

A. General

This Order may be modified, revoked and reissued, or terminated for cause. The filing of a request by the Discharger for modification, revocation and reissuance, or termination, or a notification of planned changes or anticipated noncompliance does not stay any Order condition. (40 CFR 122.41(f))

B. Duty to Reapply

If the Discharger wishes to continue an activity regulated by this Order after the expiration date of this Order, the Discharger must apply for and obtain a new permit. (40 CFR 122.41(b))

C. Transfers

This Order is not transferable to any person except after notice to the Regional Water Board. The Regional Water Board may require modification or revocation and reissuance of the Order to change the name of the Discharger and incorporate such other requirements as may be necessary under the CWA and the Water Code. (40 CFR 122.41(l)(3) and 122.61)

TENTATIVE DRAFT

III. STANDARD PROVISIONS – MONITORING

- A. Samples and measurements taken for the purpose of monitoring shall be representative of the monitored activity. (40 CFR 122.41(j)(1))
- B. Monitoring results must be conducted according to test procedures under 40 CFR Part 136 or, in the case of sludge use or disposal, approved under 40 CFR Part 136 unless otherwise specified in 40 CFR Part 503 unless other test procedures have been specified in this Order. (40 CFR 122.41(j)(4) and 122.44(i)(1)(iv))

IV. STANDARD PROVISIONS – RECORDS

- A. Except for records of monitoring information required by this Order related to the Discharger's sewage sludge use and disposal activities, which shall be retained for a period of at least 5 years (or longer as required by 40 CFR Part 503), the Discharger shall retain records of all monitoring information, including all calibration and maintenance records and all original strip chart recordings for continuous monitoring instrumentation, copies of all reports required by this Order, and records of all data used to complete the application for this Order, for a period of at least three (3) years from the date of the sample, measurement, report or application. This period may be extended by request of the Regional Water Board Executive Officer at any time. (40 CFR 122.41(j)(2))

B. Records of monitoring information shall include:

1. The date, exact place, and time of sampling or measurements (40 CFR 122.41(j)(3)(i));
2. The individual(s) who performed the sampling or measurements (40 CFR 122.41(j)(3)(ii));
3. The date(s) analyses were performed (40 CFR 122.41(j)(3)(iii));
4. The individual(s) who performed the analyses (40 CFR 122.41(j)(3)(iv));
5. The analytical techniques or methods used (40 CFR 122.41(j)(3)(v)); and
6. The results of such analyses. (40 CFR 122.41(j)(3)(vi))

C. Claims of confidentiality for the following information will be denied (40 CFR 122.7(b)):

1. The name and address of any permit applicant or Discharger (40 CFR 122.7(b)(1)); and
2. Permit applications and attachments, permits and effluent data. (40 CFR 122.7(b)(2))

TENTATIVE DRAFT

V. STANDARD PROVISIONS – REPORTING

A. Duty to Provide Information

The Discharger shall furnish to the Regional Water Board, State Water Board, or USEPA within a reasonable time, any information which the Regional Water Board, State Water Board, or USEPA may request to determine whether cause exists for modifying, revoking and reissuing, or terminating this Order or to determine compliance with this Order. Upon request, the Discharger shall also furnish to the Regional Water Board, State Water Board, or USEPA copies of records required to be kept by this Order. (40 CFR 122.41(h); Wat. Code, § 13267)

B. Signatory and Certification Requirements

1. All applications, reports, or information submitted to the Regional Water Board, State Water Board, and/or USEPA shall be signed and certified in accordance with Standard Provisions – Reporting V.B.2, V.B.3, V.B.4, and V.B.5 below. (40 CFR 122.41(k))
2. All permit applications shall be signed by either a principal executive officer or ranking elected official. For purposes of this provision, a principal executive officer of a federal agency includes: (i) the chief executive officer of the agency, or (ii) a senior executive officer having responsibility for the overall operations of a principal geographic unit of the agency (e.g., Regional Administrators of USEPA). (40 CFR 122.22(a)(3)).
3. All reports required by this Order and other information requested by the Regional Water Board, State Water Board, or USEPA shall be signed by a person described in Standard Provisions – Reporting V.B.2 above, or by a duly authorized representative of that person. A person is a duly authorized representative only if:
 - a. The authorization is made in writing by a person described in Standard Provisions – Reporting V.B.2 above (40 CFR 122.22(b)(1));
 - b. The authorization specifies either an individual or a position having responsibility for the overall operation of the regulated facility or activity such as the position of plant manager, operator of a well or a well field, superintendent, position of equivalent responsibility, or an individual or position having overall responsibility for environmental matters for the company. (A duly authorized representative may thus be either a named individual or any individual occupying a named position.) (40 CFR 122.22(b)(2)); and
 - c. The written authorization is submitted to the Regional Water Board and State Water Board. (40 CFR 122.22(b)(3))
4. If an authorization under Standard Provisions – Reporting V.B.3 above is no longer accurate because a different individual or position has responsibility for the overall operation of the facility, a new authorization satisfying the requirements of Standard

T
E
N
T
A
T
I
V
E
D
R
A
F
T

Provisions – Reporting V.B.3 above must be submitted to the Regional Water Board and State Water Board prior to or together with any reports, information, or applications, to be signed by an authorized representative. (40 CFR 122.22(c))

5. Any person signing a document under Standard Provisions – Reporting V.B.2 or V.B.3 above shall make the following certification:

“I certify under penalty of law that this document and all attachments were prepared under my direction or supervision in accordance with a system designed to assure that qualified personnel properly gather and evaluate the information submitted. Based on my inquiry of the person or persons who manage the system or those persons directly responsible for gathering the information, the information submitted is, to the best of my knowledge and belief, true, accurate, and complete. I am aware that there are significant penalties for submitting false information, including the possibility of fine and imprisonment for knowing violations.” (40 CFR 122.22(d))

C. Monitoring Reports

1. Monitoring results shall be reported at the intervals specified in the Monitoring and Reporting Program (Attachment E) in this Order. (40 CFR 122.22(l)(4))
2. Monitoring results must be reported on a Discharge Monitoring Report (DMR) form or forms provided or specified by the Regional Water Board or State Water Board for reporting results of monitoring of sludge use or disposal practices. (40 CFR 122.41(l)(4)(i))
3. If the Discharger monitors any pollutant more frequently than required by this Order using test procedures approved under 40 CFR Part 136 or, in the case of sludge use or disposal, approved under 40 CFR Part 136 unless otherwise specified in 40 CFR Part 503, or as specified in this Order, the results of this monitoring shall be included in the calculation and reporting of the data submitted in the DMR or sludge reporting form specified by the Regional Water Board. (40 CFR 122.41(l)(4)(ii))
4. Calculations for all limitations, which require averaging of measurements, shall utilize an arithmetic mean unless otherwise specified in this Order. (40 CFR 122.41(l)(4)(iii))

D. Compliance Schedules

Reports of compliance or noncompliance with, or any progress reports on, interim and final requirements contained in any compliance schedule of this Order, shall be submitted no later than 14 days following each schedule date. (40 CFR 122.41(l)(5))

E. Twenty-Four Hour Reporting

1. The Discharger shall notify the Office of Emergency Services of any noncompliance that may endanger health or the environment within two (2) hours from the time the Discharger becomes aware of the circumstances. The Discharger shall notify the

TENTATIVE DRAFT

Central Valley Water Board of the noncompliance by telephone or fax within 24 hours from the time the Discharger becomes aware of the circumstances. A written submission shall also be provided to the Central Valley Water Board within five (5) days of the time the Discharger becomes aware of the circumstances. The written submission shall contain a description of the noncompliance and its cause; the period of noncompliance, including exact dates and times, and if the noncompliance has not been corrected, the anticipated time it is expected to continue; and steps taken or planned to reduce, eliminate, and prevent reoccurrence of the noncompliance. (40 CFR 122.41(l)(6)(i))

2. The following shall be included as information that must be reported within 24 hours under this paragraph (40 CFR 122.41(l)(6)(ii)):
 - a. Any unanticipated bypass that exceeds any effluent limitation in this Order. (40 CFR 122.41(l)(6)(ii)(A))
 - b. Any upset that exceeds any effluent limitation in this Order. (40 CFR 122.41(l)(6)(ii)(B))
3. The Regional Water Board may waive the above-required written report under this provision on a case-by-case basis if an oral report has been received within 24 hours. (40 CFR 122.41(l)(6)(iii))

F. Planned Changes

The Discharger shall give notice to the Regional Water Board as soon as possible of any planned physical alterations or additions to the permitted facility. Notice is required under this provision only when (40 CFR 122.41(l)(1)):

1. The alteration or addition to a permitted facility may meet one of the criteria for determining whether a facility is a new source in 40 CFR 122.29(b) (40 CFR 122.41(l)(1)(i)); or
2. The alteration or addition could significantly change the nature or increase the quantity of pollutants discharged. This notification applies to pollutants that are not subject to effluent limitations in this Order. (40 CFR 122.41(l)(1)(ii))
3. The alteration or addition results in a significant change in the Discharger's sludge use or disposal practices, and such alteration, addition, or change may justify the application of permit conditions that are different from or absent in the existing permit, including notification of additional use or disposal sites not reported during the permit application process or not reported pursuant to an approved land application plan. (40 CFR 122.41(l)(1)(iii))

G. Anticipated Noncompliance

The Discharger shall give advance notice to the Regional Water Board or State Water Board of any planned changes in the permitted facility or activity that may result in noncompliance with General Order requirements. (40 CFR 122.41(l)(2))

TENTATIVE DRAFT

H. Other Noncompliance

The Discharger shall report all instances of noncompliance not reported under Standard Provisions – Reporting V.C, V.D, and V.E above at the time monitoring reports are submitted. The reports shall contain the information listed in Standard Provision – Reporting V.E above. (40 CFR 122.41(l)(7))

I. Other Information

When the Discharger becomes aware that it failed to submit any relevant facts in a permit application, or submitted incorrect information in a permit application or in any report to the Regional Water Board, State Water Board, or USEPA, the Discharger shall promptly submit such facts or information. (40 CFR 122.41(l)(8))

VI. STANDARD PROVISIONS – ENFORCEMENT

- A. The Regional Water Board is authorized to enforce the terms of this permit under several provisions of the Water Code, including, but not limited to, sections 13385, 13386, and 13387.

VII. ADDITIONAL PROVISIONS – NOTIFICATION LEVELS

A. Non-Municipal Facilities

Existing manufacturing, commercial, mining, and silvicultural Dischargers shall notify the Regional Water Board as soon as they know or have reason to believe (40 CFR 122.42(a)):

1. That any activity has occurred or will occur that would result in the discharge, on a routine or frequent basis, of any toxic pollutant that is not limited in this Order, if that discharge will exceed the highest of the following "notification levels" (40 CFR 122.42(a)(1)):
 - a. 100 micrograms per liter ($\mu\text{g/L}$) (40 CFR 122.42(a)(1)(i));
 - b. 200 $\mu\text{g/L}$ for acrolein and acrylonitrile; 500 $\mu\text{g/L}$ for 2,4-dinitrophenol and 2-methyl-4,6-dinitrophenol; and 1 milligram per liter (mg/L) for antimony (40 CFR 122.42(a)(1)(ii));
 - c. Five (5) times the maximum concentration value reported for that pollutant in the Report of Waste Discharge (40 CFR 122.42(a)(1)(iii)); or
 - d. The level established by the Regional Water Board in accordance with 40 CFR 122.44(f). (40 CFR 122.42(a)(1)(iv))
2. That any activity has occurred or will occur that would result in the discharge, on a non-routine or infrequent basis, of any toxic pollutant that is not limited in this Order, if that discharge will exceed the highest of the following "notification levels" (40 CFR 122.42(a)(2)):

TENTATIVE DRAFT

- a. 500 micrograms per liter ($\mu\text{g/L}$) (40 CFR 122.42(a)(2)(i));
- b. 1 milligram per liter (mg/L) for antimony (40 CFR 122.42(a)(2)(ii));
- c. Ten (10) times the maximum concentration value reported for that pollutant in the Report of Waste Discharge (40 CFR 122.42(a)(2)(iii)); or
- d. The level established by the Regional Water Board in accordance with section 122.44(f). (40 CFR 122.42(a)(2)(iv))

TENTATIVE DRAFT

ATTACHMENT E – MONITORING AND REPORTING PROGRAM

Table of Contents

I. General Monitoring Provisions..... E-2
 II. Monitoring Locations E-4
 III. Influent Monitoring Requirements – Not Applicable E-5
 IV. Effluent Monitoring Requirements E-5
 A. Monitoring Location EFF-001..... E-5
 V. Whole Effluent Toxicity Testing Requirements E-7
 VI. Land Discharge Monitoring Requirements – Not Applicable E-10
 VII. Reclamation Monitoring Requirements – Not Applicable..... E-10
 VIII. Receiving Water Monitoring Requirements – Surface Water and Groundwater E-10
 A. Monitoring Locations RSW-001 and RSW-002 E-10
 IX. Other Monitoring Requirements..... E-12
 X. Reporting Requirements..... E-13
 A. General Monitoring and Reporting Requirements..... E-13
 B. Self Monitoring Reports (SMRs) E-13
 C. Discharge Monitoring Reports (DMRs) – Not Applicable E-16
 D. Other Reports E-16

List of Tables

Table E-1. Monitoring Station Locations E-4
 Table E-2. Effluent Monitoring E-5
 Table E-3. Chronic Toxicity Testing Dilution Series E-8
 Table E-4. Receiving Water Monitoring Requirements E-10
 Table E-5. Pond Monitoring Requirements..... E-12
 Table E-6. Monitoring Periods and Reporting Schedule E-14

TENTATIVE DRAFT

ATTACHMENT E – MONITORING AND REPORTING PROGRAM

Title 40 of the Code of Federal Regulations (CFR), section 122.48 (40 CFR 122.48) requires that all NPDES permits specify monitoring and reporting requirements. California Water Code (Water Code) sections 13267 and 13383 also authorize the Regional Water Quality Control Board (Central Valley Water Board) to require technical and monitoring reports. This Monitoring and Reporting Program establishes monitoring and reporting requirements, which implement the federal and California regulations.

I. GENERAL MONITORING PROVISIONS

- A.** Samples and measurements taken as required herein shall be representative of the volume and nature of the monitored discharge. All samples shall be taken at the monitoring locations specified below and, unless otherwise specified, before the monitored flow joins or is diluted by any other waste stream, body of water, or substance. Monitoring locations shall not be changed without notification to and the approval of the Central Valley Water Board.
- B.** Effluent samples shall be taken downstream of the last addition of wastes to the treatment or discharge works where a representative sample may be obtained prior to mixing with the receiving waters. Samples shall be collected at such a point and in such a manner to ensure a representative sample of the discharge.
- C.** Chemical, bacteriological, and bioassay analyses of any material required by this Order shall be conducted by a laboratory certified for such analyses by the Department of Public Health (DPH; formerly the Department of Health Services). Laboratories that perform sample analyses must be identified in all monitoring reports submitted to the Central Valley Water Board. In the event a certified laboratory is not available to the Discharger for any onsite field measurements such as pH, turbidity, temperature and residual chlorine, such analyses performed by a noncertified laboratory will be accepted provided a Quality Assurance-Quality Control Program is instituted by the laboratory. A manual containing the steps followed in this program for any onsite field measurements such as pH, turbidity, temperature and residual chlorine must be kept onsite in the treatment facility laboratory and shall be available for inspection by Central Valley Water Board staff. The Discharger must demonstrate sufficient capability (qualified and trained employees, properly calibrated and maintained field instruments, etc.) to adequately perform these field measurements. The Quality Assurance-Quality Control Program must conform to USEPA guidelines or to procedures approved by the Central Valley Water Board.
- D.** Appropriate flow measurement devices and methods consistent with accepted scientific practices shall be selected and used to ensure the accuracy and reliability of measurements of the volume of monitored discharges. All monitoring instruments and devices used by the Discharger to fulfill the prescribed monitoring program shall be properly maintained and calibrated as necessary, at least yearly, to ensure their continued accuracy. All flow measurement devices shall be calibrated at least once per year to ensure continued accuracy of the devices.

TENTATIVE DRAFT

- E.** Monitoring results, including noncompliance, shall be reported at intervals and in a manner specified in this Monitoring and Reporting Program.
- F.** Laboratories analyzing monitoring samples shall be certified by DPH, in accordance with the provision of Water Code section 13176, and must include quality assurance/quality control data with their reports.
- G.** The Discharger shall conduct analysis on any sample provided by USEPA as part of the Discharge Monitoring Quality Assurance (DMQA) program. The results of any such analysis shall be submitted to USEPA's DMQA manager.
- H.** The Discharger shall file with the Central Valley Water Board technical reports on self-monitoring performed according to the detailed specifications contained in this Monitoring and Reporting Program.
- I.** The results of all monitoring required by this Order shall be reported to the Central Valley Water Board, and shall be submitted in such a format as to allow direct comparison with the limitations and requirements of this Order. Unless otherwise specified, discharge flows shall be reported in terms of the monthly average and the daily maximum discharge flows.

TENTATIVE DRAFT

II. MONITORING LOCATIONS

The Discharger shall establish the following monitoring locations to demonstrate compliance with the effluent limitations, discharge specifications, and other requirements in this Order:

Table E-1. Monitoring Station Locations

Discharge Point Name	Monitoring Location Name	Monitoring Location Description
001	EFF-001	Downstream from the last connection through which wastes can be admitted to the outfall. (40° 41' 36" N, 122° 24' 10" W)
--	RSW-001	Influent water from Whiskeytown Reservoir.
--	RSW-002	In Clear Creek at campground downstream of the discharge.
--	PND-001	Settling Pond 1 (southernmost)
--	PND-002	Settling Pond 2 (middle)
--	PND-003	Settling Pond 3 (northernmost)

TENTATIVE DRAFT

III. INFLUENT MONITORING REQUIREMENTS – NOT APPLICABLE

IV. EFFLUENT MONITORING REQUIREMENTS

A. Monitoring Location EFF-001

1. The Discharger shall monitor settled filter backwash water and filter rinse water at Monitoring Location EFF-001 as follows. If more than one analytical test method is listed for a given parameter, the Discharger must select from the listed methods and corresponding Minimum Level:

Table E-2. Effluent Monitoring

Parameter	Units	Sample Type	Minimum Sampling Frequency	Required Analytical Test Method
Flow	MGD	Meter	Continuous	1
Chlorine, Total Residual	mg/L	Grab	1/Day ^{2,3}	1,4
pH	standard units	Grab	2/Month ⁵	1
Settleable Solids	ml/L	Grab	2/Month	1
Total Suspended Solids	mg/L	Grab	2/Month	1
Dichlorobromomethane	µg/L	Grab	1/Month	1,6
Hardness (as CaCO ₃)	mg/L	Grab	1/Month	1
Manganese, Total Recoverable	µg/L	Grab	1/Month	1
Aluminum, Total Recoverable	µg/L	Grab	1/Quarter ⁷	1,7,8
Bis (2-ethylhexyl) Phthalate	µg/L	Grab	1/Quarter ⁷	1,6,7,9
Copper, Total Recoverable	µg/L	Grab	1/Quarter ⁷	1,6,7
Electrical Conductivity @ 25°C	µmhos/cm	Grab	1/Quarter	1
Acute Toxicity	% Survival	24-hr Composite	1/Year ¹¹	11
Chronic Toxicity	TUc	24-hr Composite	Once during permit term ¹²	12
Priority Pollutants and Other Constituents of Concern ¹³	µg/L	24-hr Composite ¹⁴	15	1,6,10

TENTATIVE DRAFT

Parameter	Units	Sample Type	Minimum Sampling Frequency	Required Analytical Test Method
-----------	-------	-------------	----------------------------	---------------------------------

TENTATIVE DRAFT

- 1 Pollutants shall be analyzed using the analytical methods described in 40 CFR Part 136.
- 2 Total chlorine residual shall be monitored prior to initiating discharges from the settling basins to Clear Creek to ensure that no detectable levels of chlorine are present in the effluent.
- 3 The monitoring frequency shall be increased to hourly during any uncontrolled overflow from the settling ponds.
- 4 Total chlorine residual must be monitored with a method sensitive to and accurate at the permitted level of 0.01 mg/L.
- 5 A hand-held field meter may be used, provided the meter utilizes a USEPA-approved algorithm/method and is calibrated and maintained in accordance with the manufacturer's instructions. A calibration and maintenance log for each meter used for monitoring required by this Monitoring and Reporting Program shall be maintained at the Facility.
- 6 For priority pollutant constituents with effluent limitations, detection limits shall be below the effluent limitations. If the lowest minimum level (ML) published in Appendix 4 of the Policy for Implementation of Toxics Standards for Inland Surface Waters, Enclosed Bays, and Estuaries of California (State Implementation Plan or SIP) is not below the effluent limitation, the detection limit shall be the lowest ML. For priority pollutant constituents without effluent limitations, the detection limits shall be equal to or less than the lowest ML published in Appendix 4 of the SIP.
- 7 Aluminum, bis (2-ethylhexyl) phthalate, and copper shall be monitored quarterly for 3 years in accordance with the special study described in Sections VI.C.2.b and VI.C.2.c of this Order.
- 8 Compliance with the final effluent limitations for aluminum can be demonstrated using either total or acid-soluble (inductively coupled plasma/atomic emission spectrometry or inductively coupled plasma/mass spectrometry) analysis methods, as supported by USEPA's Ambient Water Quality Criteria for Aluminum document (EPA 440/5-86-008), or other standard methods that exclude aluminum silicate particles as approved by the Executive Officer.
- 9 In order to verify if bis (2-ethylhexyl) phthalate is truly present in the effluent discharge, the Discharger shall take steps to assure that sample containers, sampling apparatus, and analytical equipment are not sources of the detected pollutant.
- 10 Unfiltered methylmercury and total mercury samples shall be taken using clean hands/dirty hands procedures, as described in USEPA method 1669: Sampling Ambient Water for Trace Metals at EPA Water Quality Criteria Levels, for collection of equipment blanks (section 9.4.4.2), and shall be analyzed by USEPA method 1630/1631 (Revision E) with a method detection limit of 0.02 ng/L for methylmercury and 0.2 ng/L for total mercury.
- 11 Acute toxicity shall be conducted annually in accordance with Section V.A. of this Monitoring and Reporting Program.
- 12 Chronic toxicity shall be conducted during the third or fourth year following the date of permit adoption in accordance with Section V.B. of this Monitoring and Reporting Program.
- 13 See list of Priority Pollutants and Other Constituents of Concern in Attachment I.
- 14 Volatile constituents shall be sampled in accordance with 40 CFR Part 136.
- 15 Priority pollutants and other constituents of concern shall be sampled quarterly during the third or fourth year following the date of permit adoption and shall be conducted concurrently with upstream receiving water monitoring for hardness (as CaCO₃) and pH. The Discharger is not required to conduct effluent monitoring for priority pollutants that have already been sampled during the same year as the priority pollutant sampling, as required in Table E-2. See Attachment I for more detailed requirements related to performing the priority pollutant monitoring.

2. If the discharge is intermittent rather than continuous, then on the first day of each such intermittent discharge, the Discharger shall monitor and record data for all of the constituents listed above, except for priority pollutants, after which the frequencies of analysis given in the schedule shall apply for the duration of each such intermittent discharge. In no event shall the Discharger be required to monitor and record data more often than twice the frequencies listed in the schedule.

V. WHOLE EFFLUENT TOXICITY TESTING REQUIREMENTS

A. Acute Toxicity Testing. The Discharger shall conduct acute toxicity testing to determine whether the effluent is contributing acute toxicity to the receiving water. The Discharger shall meet the following acute toxicity testing requirements:

1. Monitoring Frequency – The Discharger shall perform annual acute toxicity testing, concurrent with effluent ammonia sampling.
2. Sample Types – For static non-renewal and static renewal testing, the samples shall be flow proportional 24-hour composites and shall be representative of the volume and quality of the discharge. The effluent samples shall be taken at Monitoring Location EFF-001.
3. Test Species – Test species shall be fathead minnows (*Pimephales promelas*) or rainbow trout (*Oncorhynchus mykiss*).
4. Methods – The acute toxicity testing samples shall be analyzed using EPA-821-R-02-012, Fifth Edition. Temperature, total residual chlorine, and pH shall be recorded at the time of sample collection. No pH adjustment may be made unless approved by the Executive Officer.
5. Test Failure – If an acute toxicity test does not meet all test acceptability criteria, as specified in the test method, the Discharger must re-sample and re-test as soon as possible, not to exceed 7 days following notification of test failure.

B. Chronic Toxicity Testing. The Discharger shall conduct three species chronic toxicity testing to determine whether the effluent is contributing chronic toxicity to the receiving water. The Discharger shall meet the following chronic toxicity testing requirements:

1. Monitoring Frequency – The Discharger shall perform three species chronic toxicity testing once during the third or fourth year of the permit term.
2. Sample Types – Effluent samples shall be flow proportional 24-hour composites and shall be representative of the volume and quality of the discharge. The effluent samples shall be taken at Monitoring Location EFF-001. The receiving water control shall be a grab sample obtained from the Monitoring Location RSW-001, as identified in this Monitoring and Reporting Program.
3. Sample Volumes – Adequate sample volumes shall be collected to provide renewal water to complete the test in the event that the discharge is intermittent.
4. Test Species – Chronic toxicity testing measures sublethal (e.g., reduced growth, reproduction) and/or lethal effects to test organisms exposed to an effluent compared to that of the control organisms. The Discharger shall conduct chronic toxicity tests with:
 - The cladoceran, water flea, *Ceriodaphnia dubia* (survival and reproduction test);

TENTATIVE DRAFT

- The fathead minnow, *Pimephales promelas* (larval survival and growth test); and
 - The green alga, *Selenastrum capricornutum* (growth test).
5. **Methods** – The presence of chronic toxicity shall be estimated as specified in *Short-term Methods for Estimating the Chronic Toxicity of Effluents and Receiving Waters to Freshwater Organisms, Fourth Edition, EPA/821-R-02-013, October 2002.*
 6. **Reference Toxicant** – As required by the SIP, all chronic toxicity tests shall be conducted with concurrent testing with a reference toxicant and shall be reported with the chronic toxicity test results.
 7. **Dilutions** – For regular and accelerated chronic toxicity monitoring, it is not necessary to perform the test using a dilution series. The test may be performed using 100% effluent and two controls. For TRE monitoring, the chronic toxicity testing shall be performed using the dilution series identified in Table E-3, below. The receiving water control shall be used as the diluent (unless the receiving water is toxic).

Table E-3. Chronic Toxicity Testing Dilution Series

Sample	Dilutions (%)					Controls	
	100	75	50	25	12.5	Receiving Water	Laboratory Water
% Effluent	100	75	50	25	12.5	0	0
% Receiving Water	0	25	50	75	87.5	100	0
% Laboratory Water	0	0	0	0	0	0	100

8. **Test Failure** – The Discharger must re-sample and re-test as soon as possible, but no later than fourteen (14) days after receiving notification of a test failure. A test failure is defined as follows:
 - a. The reference toxicant test or the effluent test does not meet all test acceptability criteria as specified in the *Short-term Methods for Estimating the Chronic Toxicity of Effluents and Receiving Waters to Freshwater Organisms, Fourth Edition, EPA/821-R-02-013, October 2002 (Method Manual),* and its subsequent amendments or revisions; or
 - b. The percent minimum significant difference (PMSD) measured for the test exceeds the upper PMSD bound variability criterion in Table 6 on page 52 of the Method Manual. (A retest is only required in this case if the test results do not exceed the monitoring trigger specified in the Special Provision at section VI. 2.a.iii. of the Order.)

C. WET Testing Notification Requirements. The Discharger shall notify the Central Valley Water Board within 24-hours after the receipt of test results exceeding the monitoring trigger during regular or accelerated monitoring, or an exceedance of the acute toxicity effluent limitation.

TENTATIVE DRAFT

D. WET Testing Reporting Requirements. All toxicity test reports shall include the contracting laboratory's complete report provided to the Discharger and shall be in accordance with the appropriate "Report Preparation and Test Review" sections of the method manuals. At a minimum, whole effluent toxicity monitoring shall be reported as follows:

- 1. Chronic WET Reporting.** Regular chronic toxicity monitoring results shall be reported to the Central Valley Water Board within 30 days following completion of the test, and shall contain, at minimum:
 - c. The results expressed in TUc, measured as 100/NOEC, and also measured as 100/LC50, 100/EC25, 100/IC25, and 100/IC50, as appropriate.
 - d. The statistical methods used to calculate endpoints;
 - e. The statistical output page, which includes the calculation of the percent minimum significant difference (PMSD);
 - f. The dates of sample collection and initiation of each toxicity test; and
 - g. The results compared to the numeric toxicity monitoring trigger.

Additionally, the monthly discharger self-monitoring reports shall contain an updated chronology of chronic toxicity test results expressed in TUc, and organized by test species, type of test (survival, growth or reproduction), and monitoring frequency, i.e., either quarterly, monthly, accelerated, or Toxicity Reduction Evaluation (TRE).

- 2. Acute WET Reporting.** Acute toxicity test results shall be submitted with the monthly discharger self-monitoring reports and reported as percent survival.
- 3. TRE Reporting.** Reports for TREs shall be submitted in accordance with the schedule contained in the Discharger's approved TRE Workplan.
- 4. Quality Assurance (QA).** The Discharger must provide the following information for QA purposes:
 - a. Results of the applicable reference toxicant data with the statistical output page giving the species, NOEC, LOEC, type of toxicant, dilution water used, concentrations used, PMSD, and dates tested.
 - b. The reference toxicant control charts for each endpoint, which include summaries of reference toxicant tests performed by the contracting laboratory.
 - c. Any information on deviations or problems encountered and how they were dealt with.

TENTATIVE DRAFT

VI. LAND DISCHARGE MONITORING REQUIREMENTS – NOT APPLICABLE

VII. RECLAMATION MONITORING REQUIREMENTS – NOT APPLICABLE

VIII. RECEIVING WATER MONITORING REQUIREMENTS – SURFACE WATER AND GROUNDWATER

A. Monitoring Locations RSW-001 and RSW-002

1. The Discharger shall monitor Clear Creek at Monitoring Location RSW-001 and RSW-002 as follows:

Table E-4. Receiving Water Monitoring Requirements

Parameter	Units	Sample Type	Minimum Sampling Frequency	Required Analytical Test Method
pH	standard units	Grab	1/Week	1,2
Turbidity	NTU	Grab	1/Week	1,2
Hardness, Total (as CaCO ₃)	mg/L	Grab	1/Month ³	1,2
Aluminum, Total Recoverable	µg/L	Grab	1/Quarter ⁴	1,4,5
Bis (2-ethylhexyl) Phthalate	µg/L	Grab	1/Quarter ⁴	1,4,6
Copper, Total Recoverable	µg/L	Grab	1/Quarter ⁴	1,4
Priority Pollutants and Other Constituents of Concern ⁷	µg/L	Grab	⁸	1,9

TENTATIVE DRAFT

Parameter	Units	Sample Type	Minimum Sampling Frequency	Required Analytical Test Method
-----------	-------	-------------	----------------------------	---------------------------------

- 1 Pollutants shall be analyzed using the analytical methods described in 40 CFR Part 136.
- 2 A hand-held field meter may be used, provided the meter utilizes a USEPA-approved algorithm/method and is calibrated and maintained in accordance with the manufacturer's instructions. A calibration and maintenance log for each meter used for monitoring required by this Monitoring and Reporting Program shall be maintained at the Facility.
- 3 Monitoring required at Monitoring Location RSW-001, only. Samples shall be collected on the same date as the effluent metals and priority pollutant samples.
- 4 Aluminum, bis (2-ethylhexyl) phthalate, and copper shall be monitored at Monitoring Location RSW-001 for 3 years as part of the special studies described in Section VI.C.2.b and VI.C.2.c of this Order. Samples shall be collected on the same date as effluent sampling for these parameters.
- 5 Aluminum can be monitored using either total or acid-soluble (inductively coupled plasma/atomic emission spectrometry or inductively coupled plasma/mass spectrometry) analysis methods, as supported by USEPA's Ambient Water Quality Criteria for Aluminum document (EPA 440/5-86-008), or other standard methods that exclude aluminum silicate particles as approved by the Executive Officer.
- 6 In order to verify if bis (2-ethylhexyl) phthalate is truly present in the receiving water, the Discharger shall take steps to assure that sample containers, sampling apparatus, and analytical equipment are not sources of the detected pollutant.
- 7 See list of Priority Pollutants and Other Constituents of Concern in Attachment I.
- 8 Priority pollutants shall be sampled quarterly during the third or fourth year following the date of permit adoption at Monitoring Location RSW-001 and shall be conducted concurrently with effluent monitoring for priority pollutants. See Attachment I for more detailed requirements related to performing priority pollutant monitoring.
- 9 Pollutants shall be analyzed using the analytical methods described in 40 CFR Part 136; for priority pollutants the methods must meet the lowest minimum levels (MLs) specified in Appendix 4 of the SIP, where no methods are specified for a given pollutant, by methods approved by the Central Valley Water Board or the State Water Board.

2. In conducting the receiving water sampling, a log shall be kept of the receiving water conditions in the vicinity of Monitoring Location RSW-002. Attention shall be given to the presence and absence of:
 - a. Floating or suspended matter;
 - b. Discoloration;
 - c. Bottom deposits;
 - d. Aquatic life;
 - e. Visible films, sheens, or coatings;
 - f. Fungi, slimes, or objectionable growths; and
 - g. Potential nuisance conditions.

Notes on receiving water conditions shall be summarized in the monitoring report.

TENTATIVE DRAFT

IX. OTHER MONITORING REQUIREMENTS

A. Monitoring Locations PND-001, PND-002, and PND-003

1. The Discharger shall monitor the settling basins when water is present at Monitoring locations PND-001, PND-002, and PND-003 as follows.

Table E-5. Pond Monitoring Requirements

Parameter	Units	Sample Type	Minimum Sampling Frequency	Required Analytical Test Method
Freeboard	Feet	Measure ¹	1/Week	²
Dissolved Oxygen	mg/L	Grab	1/Week	2,3
Odors	--	Observation	1/Week	--
pH	standard units	Grab	1/Week	2,3
Electrical Conductivity @ 25°C	µmhos/cm	Grab	1/Week	2,3
Aluminum, Total Recoverable	µg/L	Grab	1/Quarter ^{4,5}	2,5,6
Bis (2-ethylhexyl) Phthalate	µg/L	Grab	1/Quarter ^{4,5}	2,5,7
Copper, Total Recoverable	µg/L	Grab	1/Quarter ^{4,5}	2,5
Iron, Total Recoverable	µg/L	Grab	1/Quarter	²

¹ To be measured vertically to the lowest point of overflow.

² Pollutants shall be analyzed using the analytical methods described in 40 CFR Part 136.

³ A hand-held field meter may be used, provided the meter utilizes a USEPA-approved algorithm/method and is calibrated and maintained in accordance with the manufacturer's instructions. A calibration and maintenance log for each meter used for monitoring required by this Monitoring and Reporting Program shall be maintained at the Facility.

⁴ If during the period of sample frequency there has been a discharge from Monitoring Location PND-001, PND-002, and/or PND-003 and the parameter has been sampled at Monitoring Location EFF-001 the Discharger may use the result from Monitoring Location EFF-001 for the required pond monitoring.

⁵ Aluminum, bis (2-ethylhexyl) phthalate, and copper shall be monitored for 3 years as part of the special studies described in Sections VI.C.2.b and VI.C.2.c. of this Order.

⁶ Aluminum can be monitored using either total or acid-soluble (inductively coupled plasma/atomic emission spectrometry or inductively coupled plasma/mass spectrometry) analysis methods, as supported by USEPA's Ambient Water Quality Criteria for Aluminum document (EPA 440/5-86-008), or other standard methods that exclude aluminum silicate particles as approved by the Executive Officer.

⁷ In order to verify if bis (2-ethylhexyl) phthalate is truly present in the ponds, the Discharger shall take steps to assure that sample containers, sampling apparatus, and analytical equipment are not sources of the detected pollutant.

B. Solids Monitoring – Monitoring Locations PND-001, PND-002, and PND-003

1. The Discharger shall submit a report by **31 January** of each year for disposal of sludge from the settling basins at Monitoring Locations PND-001, PND-002, and PND-003, which shall include the following:
 - a. Estimate of sludge removed in dry tons.

- b. Description of on-site sludge storage (if applicable).
- c. A description of disposal methods, including the names and locations of facilities receiving sludge.
- d. A representative characterization of sludge quality including percent solids and quantitative results of chemical analyses for Title 22 metals.

X. REPORTING REQUIREMENTS

A. General Monitoring and Reporting Requirements

1. The Discharger shall comply with all Standard Provisions (Attachment D) related to monitoring, reporting, and recordkeeping.
2. Upon written request of the Central Valley Water Board, the Discharger shall submit a summary monitoring report. The report shall contain both tabular and graphical summaries of the monitoring data obtained during the previous year(s).
3. **Compliance Time Schedules.** For compliance time schedules included in the Order, the Discharger shall submit to the Central Valley Water Board, on or before each compliance due date, the specified document or a written report detailing compliance or noncompliance with the specific date and task. If noncompliance is reported, the Discharger shall state the reasons for noncompliance and include an estimate of the date when the Discharger will be in compliance. The Discharger shall notify the Central Valley Water Board by letter when it returns to compliance with the compliance time schedule.
4. The Discharger shall report to the Central Valley Water Board any toxic chemical release data it reports to the State Emergency Response Commission within 15 days of reporting the data to the Commission pursuant to section 313 of the "*Emergency Planning and Community Right to Know Act*" of 1986.

B. Self Monitoring Reports (SMRs)

1. The Discharger shall continue to submit eSMRs using the State Water Board's CIWQS Program Web site (<http://www.waterboards.ca.gov/ciwqs/index.html>). The Discharger shall maintain sufficient staffing and resources to ensure it submits eSMRs during the effective duration of this Order. This includes provision of training and supervision of individuals (e.g., Discharger personnel or consultant) on how to prepare and submit eSMRs.
2. Monitoring periods and reporting for all required monitoring shall be completed according to the following schedule:

TENTATIVE DRAFT

Table E-6. Monitoring Periods and Reporting Schedule

Sampling Frequency	Monitoring Period Begins On...	Monitoring Period	SMR Due Date
Continuous	Permit effective date	All	First day of second calendar month following month of sampling.
1/Week	Permit effective date	Sunday through Saturday	First day of second calendar month following month of sampling.
1/Month	Permit effective date	First day of calendar month through last day of calendar month	First day of second calendar month following month of sampling.
1/Quarter	Permit effective date	1 January through 31 March 1 April through 30 June 1 July through 30 September 1 October through 31 December	1 May 1 August 1 November 1 February
1/Year	Permit effective date	1 January through 31 December	1 February

- 3. Reporting Protocols.** The Discharger shall report with each sample result the applicable reported Minimum Level (ML) and the current Method Detection Limit (MDL), as determined by the procedure in 40 CFR Part 136.

The Discharger shall report the results of analytical determinations for the presence of chemical constituents in a sample using the following reporting protocols:

- a. Sample results greater than or equal to the reported ML shall be reported as measured by the laboratory (i.e., the measured chemical concentration in the sample).
- b. Sample results less than the RL, but greater than or equal to the laboratory’s MDL, shall be reported as “Detected, but Not Quantified,” or DNQ. The estimated chemical concentration of the sample shall also be reported.

For the purposes of data collection, the laboratory shall write the estimated chemical concentration next to DNQ as well as the words “Estimated Concentration” (may be shortened to “Est. Conc.”). The laboratory may, if such information is available, include numerical estimates of the data quality for the reported result. Numerical estimates of data quality may be percent accuracy (+ a percentage of the reported value), numerical ranges (low to high), or any other means considered appropriate by the laboratory.

- c. Sample results less than the laboratory’s MDL shall be reported as “Not Detected,” or ND.
- d. Dischargers are to instruct laboratories to establish calibration standards so that the ML value (or its equivalent if there is differential treatment of samples relative to calibration standards) is the lowest calibration standard. At no time is the Discharger to use analytical data derived from extrapolation beyond the lowest point of the calibration curve.

TENTATIVE DRAFT

- 4. Compliance Determination.** Compliance with effluent limitations for priority pollutants shall be determined using sample reporting protocols defined above and in Attachment A of this Order. For purposes of reporting and administrative enforcement by the Central Valley Water Board and the State Water Board, the Discharger shall be deemed out of compliance with effluent limitations if the concentration of the priority pollutant in the monitoring sample is greater than the effluent limitation and greater than or equal to the reporting level (RL).
- 5. Multiple Sample Data.** When determining compliance with an AMEL, AWEL, or MDEL for priority pollutants and more than one sample result is available, the Discharger shall compute the arithmetic mean unless the data set contains one or more reported determinations of “Detected, but Not Quantified” (DNQ) or “Not Detected” (ND). In those cases, the Discharger shall compute the median in place of the arithmetic mean in accordance with the following procedure:

 - a. The data set shall be ranked from low to high, ranking the reported ND determinations lowest, DNQ determinations next, followed by quantified values (if any). The order of the individual ND or DNQ determinations is unimportant.
 - b. The median value of the data set shall be determined. If the data set has an odd number of data points, then the median is the middle value. If the data set has an even number of data points, then the median is the average of the two values around the middle unless one or both of the points are ND or DNQ, in which case the median value shall be the lower of the two data points where DNQ is lower than a value and ND is lower than DNQ.
- 6. Reporting Requirements.** In reporting the monitoring data, the Discharger shall arrange the data in tabular form so that the date, the constituents, and the concentrations are readily discernible.

 - a. The data shall be summarized to clearly illustrate whether the facility is operating in compliance with interim and/or final effluent limitations or with other waste discharge requirements (e.g., discharge specifications, receiving water limitations, special provisions, etc.).
 - b. Reports must clearly show when discharging to EFF-001 or other permitted discharge locations. Reports must show the date and time that the discharge started and stopped at each location.
 - c. The highest daily maximum for the month and monthly and weekly averages shall be determined and recorded as needed to demonstrate compliance.
- 7. Calculation Requirements.** The following shall be calculated and reported in the SMRs:

 - a. **Annual Average Limitations.** For constituents with effluent limitations specified as “annual average” (manganese) the Discharger shall report the

annual average in the December SMR. The annual average shall be calculated as the average of the samples gathered for the calendar year.

- b. Dissolved Oxygen Receiving Water Limitations.** The Discharger shall calculate and report monthly in the self-monitoring report: i) the dissolved oxygen concentration, ii) the percent of saturation in the main water mass, and iii) the 95th percentile dissolved oxygen concentration.
 - c. Turbidity Receiving Water Limitations.** The Discharger shall calculate and report the turbidity increase in the receiving water applicable to the natural turbidity condition specified in Section V.A.17.a-e. of the Limitations and Discharge Requirements.
 - d. Temperature Receiving Water Limitations.** The Discharger shall calculate and report the temperature increase in the receiving water based on the difference in temperature at RSW-001 and RSW-002.
8. The Discharger shall submit SMRs in accordance with the following requirements:
- a.** When electronic submittal of data is required and CIWQS does not provide for entry into a tabular format within the system, the Discharger shall electronically submit the data in a tabular format as an attachment. The Discharger is not required to duplicate the submittal of data that is entered in a tabular format within CIWQS.
 - b.** The Discharger shall attach a cover letter to the SMR. The information contained in the cover letter shall clearly identify violations of the WDRs; discuss corrective actions taken or planned; and the proposed time schedule for corrective actions. Identified violations must include a description of the requirement that was violated and a description of the violation.
 - c.** SMRs must be submitted to the Central Valley Water Board, signed and certified as required by the Standard Provisions (Attachment D), to the address listed below:

Regional Water Quality Control Board
Central Valley Region
NPDES Compliance and Enforcement Unit
415 Knollcrest Drive
Redding, CA 96002

C. Discharge Monitoring Reports (DMRs) – Not Applicable

D. Other Reports

- 1. The Discharger shall report the results of any special studies, acute and chronic toxicity testing, TRE/TIE, PMP, and Pollution Prevention Plan required by Special Provisions VI.C of this Order. The Discharger shall submit reports with the first

TENTATIVE DRAFT

monthly SMR scheduled to be submitted on or immediately following the report due date.

2. Within 60 days of permit adoption, the Discharger shall submit a report outlining minimum levels, method detection limits, and analytical methods for approval, with a goal to achieve detection levels below applicable water quality criteria. At a minimum, the Discharger shall comply with the monitoring requirements for CTR constituents as outlined in section 2.3 and 2.4 of the SIP.
3. **Annual Operations Report.** By 30 January of each year, the Discharger shall submit a written report to the Executive Officer containing the following:
 - a. The names, certificate grades, and general responsibilities of all persons employed at the Facility.
 - b. The names and telephone numbers of persons to contact regarding the plant for emergency and routine situations.
 - c. A statement certifying when the flow meter(s) and other monitoring instruments and devices were last calibrated, including identification of who performed the calibration.
 - d. A statement certifying whether the current operation and maintenance manual, and contingency plan, reflect the wastewater treatment plant as currently constructed and operated, and the dates when these documents were last revised and last reviewed for adequacy.
 - e. The Discharger may also be requested to submit an annual report to the Central Valley Water Board with both tabular and graphical summaries of the monitoring data obtained during the previous year. Any such request shall be made in writing. The report shall discuss the compliance record. If violations have occurred, the report shall also discuss the corrective actions taken and planned to bring the discharge into full compliance with the waste discharge requirements.

TENTATIVE DRAFT

ATTACHMENT F – FACT SHEET

Table of Contents

I.	Permit Information	F-3
II.	Facility Description	F-4
	A. Description of Wastewater and Biosolids Treatment or Controls	F-4
	B. Discharge Points and Receiving Waters.....	F-5
	C. Summary of Existing Requirements and Self-Monitoring Report (SMR) Data	F-5
	D. Compliance Summary.....	F-6
	E. Planned Changes – Not Applicable	F-6
III.	Applicable Plans, Policies, and Regulations.....	F-6
	A. Legal Authorities	F-6
	B. California Environmental Quality Act (CEQA)	F-6
	C. State and Federal Regulations, Policies, and Plans	F-6
	D. Impaired Water Bodies on CWA 303(d) List	F-7
	E. Other Plans, Policies and Regulations.....	F-8
IV.	Rationale For Effluent Limitations and Discharge Specifications.....	F-9
	A. Discharge Prohibitions	F-10
	B. Technology-Based Effluent Limitations.....	F-11
	1. Scope and Authority.....	F-11
	2. Applicable Technology-Based Effluent Limitations	F-12
	C. Water Quality-Based Effluent Limitations (WQBELs).....	F-13
	1. Scope and Authority.....	F-13
	2. Applicable Beneficial Uses and Water Quality Criteria and Objectives	F-13
	3. Determining the Need for WQBELs	F-24
	4. WQBEL Calculations	F-36
	5. Whole Effluent Toxicity (WET)	F-38
	D. Final Effluent Limitations.....	F-40
	1. Mass-based Effluent Limitations	F-40
	2. Averaging Periods for Effluent Limitations	F-40
	3. Satisfaction of Anti-Backsliding Requirements.....	F-40
	4. Satisfaction of Antidegradation Policy.....	F-41
	5. Stringency of Requirements for Individual Pollutants.....	F-42
	E. Interim Effluent Limitations – Not Applicable.....	F-43
	F. Land Discharge Specifications – Not Applicable.....	F-43
	G. Reclamation Specifications – Not Applicable	F-43
V.	Rationale for Receiving Water Limitations	F-43
	A. Surface Water.....	F-44
	B. Groundwater	F-46
VI.	Rationale for Monitoring and Reporting Requirements.....	F-46
	A. Influent Monitoring – Not Applicable	F-47
	B. Effluent Monitoring.....	F-47
	C. Whole Effluent Toxicity Testing Requirements	F-49
	D. Receiving Water Monitoring.....	F-49
	1. Surface Water	F-49

TENTATIVE DRAFT

- 2. Groundwater – Not Applicable F-50
- E. Other Monitoring Requirements F-50
- VII. Rationale for Provisions F-50
 - A. Standard Provisions F-50
 - B. Special Provisions F-50
 - 1. Reopener Provisions F-50
 - 2. Special Studies and Additional Monitoring Requirements F-51
 - 3. Best Management Practices and Pollution Prevention – Not Applicable F-55
 - 4. Construction, Operation, and Maintenance Specifications F-55
 - 5. Special Provisions for Municipal Facilities (POTWs Only) – Not Applicable F-55
 - 6. Other Special Provisions F-55
 - 7. Compliance Schedules – Not Applicable F-56
- VIII. Public Participation F-56
 - A. Notification of Interested Parties F-56
 - B. Written Comments F-56
 - C. Public Hearing F-56
 - D. Waste Discharge Requirements Petitions F-57
 - E. Information and Copying F-57
 - F. Register of Interested Persons F-57
 - G. Additional Information F-57

List of Tables

- Table F-1. Facility Information F-3
- Table F-2. Historic Effluent Limitations and Monitoring Data F-5
- Table F-3. Summary of TSS Effluent Limitations in General Permits F-12
- Table F-4. Summary of Technology-based Effluent Limitations F-13
- Table F-5. Basin Plan Beneficial Uses F-14
- Table F-6. Chronic Zinc ECA Evaluation F-21
- Table F-7. Chronic Copper ECA Evaluation F-22
- Table F-8. Lead ECA Evaluation F-24
- Table F-9. Summary of ECA Evaluations for CTR Hardness-dependent Metals F-24
- Table F-10. Salinity Water Quality Criteria/Objectives F-25
- Table F-11. Site-Specific pH and Hardness Characteristics F-29
- Table F-11. Summary of Water Quality-Based Effluent Limitations F-37
- Table F-12. Whole Effluent Chronic Toxicity Testing Results F-39
- Table F-13. Summary of Final Effluent Limitations F-42

TENTATIVE DRAFT

ATTACHMENT F – FACT SHEET

As described in the Findings in section II of this Order, this Fact Sheet includes the legal requirements and technical rationale that serve as the basis for the requirements of this Order.

This Order has been prepared under a standardized format to accommodate a broad range of discharge requirements for Dischargers in California. Only those sections or subsections of this Order that are specifically identified as “not applicable” have been determined not to apply to this Discharger. Sections or subsections of this Order not specifically identified as “not applicable” are fully applicable to this Discharger.

I. PERMIT INFORMATION

The following table summarizes administrative information related to the Facility.

Table F-1. Facility Information

WDID	5A450120001
Discharger	Clear Creek Community Services District (CSD)
Name of Facility	Clear Creek CSD Water Treatment Plant
Facility Address	Paige Bar Road
	Igo, CA 96047
	Shasta County
Facility Contact, Title and Phone	Ronald Carlin, Plant Operator, (530) 357-2121
Authorized Person to Sign and Submit Reports	Ronald Carlin, Plant Operator, (530) 357-2121
Mailing Address	5880 Oak Street, Anderson, CA 96007
Billing Address	Same as mailing address
Type of Facility	Water treatment plant (SIC Code 4941)
Major or Minor Facility	Minor
Threat to Water Quality	3
Complexity	B
Pretreatment Program	Not applicable
Reclamation Requirements	Not applicable
Facility Permitted Flow	1.5 million gallons per day (MGD)
Facility Design Flow	1.5 MGD
Watershed	Sacramento – Upper Clear
Receiving Water	Clear Creek
Receiving Water Type	Inland surface water

- A.** Clear Creek CSD (hereinafter Discharger) is the owner and operator of the Clear Creek CSD Water Treatment Plant (hereinafter Facility).

For the purposes of this Order, references to the “discharger” or “permittee” in applicable federal and state laws, regulations, plans, or policy are held to be equivalent to references to the Discharger herein.

TENTATIVE DRAFT

- B.** The Facility discharges wastewater to Clear Creek, a water of the United States, and is currently regulated by Order No. R5-2006-0116 which was adopted on 27 October 2006 and expired on 16 December 2011. The terms and conditions of the current Order have been automatically continued and remain in effect until new Waste Discharge Requirements (WDRs) and National Pollutant Discharge Elimination System (NPDES) permit are adopted pursuant to this Order.
- C.** The Discharger filed a report of waste discharge (ROWD) and submitted an application for renewal of its WDRs and NPDES permit on 2 June 2011. Supplemental information was requested on 13 July and 19 July and received on 14 July and 20 July. A site visit was conducted on 20 June 2011, to observe operations and collect additional data to develop permit limitations and conditions.

II. FACILITY DESCRIPTION

The Facility provides up to 25 MGD of potable water to domestic and agricultural customers in the service areas of Clear Creek CSD and Centerville CSD.

A. Description of Wastewater and Biosolids Treatment or Controls

Raw water for the Facility is piped via a 45-inch raw water supply line tapped directly into the Whiskeytown Dam water outlet works to the Facility. Treatment of drinking water at the Facility consists of chlorination; coagulation; filtration through eight horizontal, multi-cell pressure filters, and post-chlorination. Post-chlorination is adjusted to a level that achieves the required chlorine residual in the potable water distribution system.

Filter backwash water is generated in the drinking water treatment process, which is routed to any of the three settling ponds. During the summer, up to 300,000 gallons per day (gpd) of filter backwash water may be routed to the ponds. During winter months, as little as 65,000 gpd may be discharged, which may not occur on a daily basis. After backwashing of filters, the filters are rinsed with treated water, which has not been subjected to post-chlorination. The rinse water is stored in a separate, cement-lined pond and recycled through the headworks of the plant. Under conditions of high frequency backwashes, when the capacity of the rinse pond is exceeded, filter rinse water may be diverted to the settling pond with the lowest elevation.

The Discharger discharges from the settling ponds to Clear Creek. During normal operating conditions, a floating outlet at the west end of each pond drains water from the top few inches of the pond surface into the 12-inch drain pipe connected to the three ponds. The drain pipe leads to a drainage channel that flows into Clear Creek after a short distance. If the flow rate through the floating outlet is not adequate to prevent the water level in a pond from reaching the overflow elevation, then larger capacity discharge piping allows the water above the overflow elevation to drain into the 12-inch pipe.

TENTATIVE DRAFT

The Discharger periodically takes a pond out of service during the summer to permit solids to dry and allow removal. Sludge removed from the ponds is transported to the Shasta County landfill for disposal.

Order No. R5-2006-0116 included effluent limitations and special provisions for non-backwash waters, such as well development water, construction dewatering, pump/well testing, pipeline/tank pressure testing, pipeline/tank flushing or dewatering, condensate discharges, unspecified water supply system discharges, and other miscellaneous dewatering/low threat discharges. These types of discharges are covered by the Regional Water Quality Control Board, Central Valley Region (Central Valley Water Board) General Order No. R5-2008-0081, Waste Discharge Requirements for Dewatering and Other Low Threat Discharges (Low Threat General Order). Therefore, this Order does not retain the requirements for non-backwash waters and the Discharger is required to submit a Notice of Intent (NOI) for coverage under the Low Threat General Order for discharges of non-backwash waters.

B. Discharge Points and Receiving Waters

1. The Facility is located in Section 27, T32N, R6W, MDB&M, as shown in Attachment B, a part of this Order.
2. Settled filter backwash water and filter rinse water is discharged at Discharge Point No. 001 to Clear Creek, a water of the United States and a tributary to the Sacramento River at a point latitude 40° 41' 36" N and longitude 122° 24' 10" W.

C. Summary of Existing Requirements and Self-Monitoring Report (SMR) Data

Effluent limitations contained in Order No. R5-2006-0116 for discharges from Discharge Point No. 001 (Monitoring Location EFF-001) and representative monitoring data from the term of Order No. R5-2006-0116 are as follows:

Table F-2. Historic Effluent Limitations and Monitoring Data

Parameter	Units	Effluent Limitation			Monitoring Data (From January 2007 To May 2011)		
		Average Monthly	Average Weekly	Maximum Daily	Highest Average Monthly Discharge	Highest Average Weekly Discharge	Highest Daily Discharge
Flow	MGD	--	--	1.5	--	--	0.990
Settleable Solids	m/L	0.1	--	0.2	NR	--	<0.1
Total Suspended Solids	mg/L	30	--	50	NR	--	3
pH	standard units	--	--	6.0 – 9.0	--	--	6.6 – 7.9
Chlorine, Total Residual	mg/L	--	0.01 ¹	0.02 ²	--	--	<0.02

TENTATIVE DRAFT

Parameter	Units	Effluent Limitation			Monitoring Data (From January 2007 To May 2011)		
		Average Monthly	Average Weekly	Maximum Daily	Highest Average Monthly Discharge	Highest Average Weekly Discharge	Highest Daily Discharge
Acute Toxicity	% Survival	--	--	3	--	--	70 ⁴

NR = Not Reported

- ¹ Applied as a 4-day average effluent limitation.
- ² Applied as a 1-hour average effluent limitation.
- ³ Survival of aquatic organisms in 96-hour bioassays of undiluted waste shall be no less than:
 Minimum for any one bioassay: 70%
 Median for any three or more consecutive bioassays: 90%
- ⁴ Represents the minimum observed percent survival.

D. Compliance Summary

Compliance inspections of the Facility were conducted on 21 September 2007 and 29 November 2010. No major violations were noted during the inspections.

E. Planned Changes – Not Applicable

III. APPLICABLE PLANS, POLICIES, AND REGULATIONS

The requirements contained in this Order are based on the applicable plans, policies, and regulations identified in the Findings in section II of this Order. The applicable plans, policies, and regulations relevant to the discharge include the following:

A. Legal Authorities

This Order is issued pursuant to regulations in the Clean Water Act (CWA) and the California Water Code (Water Code) as specified in the Finding contained at section II.C of this Order.

B. California Environmental Quality Act (CEQA)

This Order meets the requirements of CEQA as specified in the Finding contained at section II.E of this Order.

C. State and Federal Regulations, Policies, and Plans

- 1. Water Quality Control Plans.** This Order implements the following water quality control plans as specified in the Finding contained at section II.H of this Order.
 - a. *Water Quality Control Plan, Fourth Edition (Revised October 2011), for the Sacramento and San Joaquin River Basins* (Basin Plan)
- 2. National Toxics Rule (NTR) and California Toxics Rule (CTR).** This Order implements the NTR and CTR as specified in the Finding contained at section II.I of this Order.

TENTATIVE DRAFT

3. **State Implementation Policy (SIP).** This Order implements the SIP as specified in the Finding contained at section II.J of this Order.
4. **Alaska Rule.** This Order is consistent with the Alaska Rule as specified in the Finding contained at section II.L of this Order.
5. **Antidegradation Policy.** As specified in the Finding contained at section II.N of this Order and as discussed in detail in the Fact Sheet (Attachment F, Section IV.D.4.), the discharge is consistent with the antidegradation provisions of 40 CFR 131.12 and State Water Resources Control Board (State Water Board) Resolution 68-16.
6. **Anti-Backsliding Requirements.** This Order is consistent with anti-backsliding policies as specified in the Finding contained at section II.O of this Order. Compliance with the anti-backsliding requirements is discussed in the Fact Sheet (Attachment F, Section IV.D.3).
7. **Storm Water Requirements.** USEPA promulgated federal regulations for storm water on 16 November 1990 in 40 CFR Parts 122, 123, and 124. The NPDES Industrial Storm Water Program regulates storm water discharges from industrial activities. Water treatment facilities are not applicable industries under the storm water program and are not required to be covered under the State Water Board's General Industrial Storm Water Permit.
8. **Endangered Species Act.** This Order is consistent with the Endangered Species Act as specified in the Finding contained at section II.P of this Order.

D. Impaired Water Bodies on CWA 303(d) List

1. Under section 303(d) of the 1972 CWA, states, territories and authorized tribes are required to develop lists of water quality limited segments. The waters on these lists do not meet water quality standards, even after point sources of pollution have installed the minimum required levels of pollution control technology. On 30 November 2006 USEPA gave final approval to California's 2006 section 303(d) List of Water Quality Limited Segments. The Basin Plan references this list of Water Quality Limited Segments (WQLSs), which are defined as "*...those sections of lakes, streams, rivers or other fresh water bodies where water quality does not meet (or is not expected to meet) water quality standards even after the application of appropriate limitations for point sources (40 CFR Part 130, et seq.)*." The Basin Plan also states, "*Additional treatment beyond minimum federal standards will be imposed on dischargers to [WQLSs]. Dischargers will be assigned or allocated a maximum allowable load of critical pollutants so that water quality objectives can be met in the segment.*" Clear Creek is listed on the 2010 303(d) list as impaired for mercury. The Sacramento River from Keswick Dam to Cottonwood Creek downstream of the discharge is listed on the 2010 303(d) list as impaired for unknown toxicity.

TENTATIVE DRAFT

- 2. Total Maximum Daily Loads (TMDLs).** USEPA requires the Central Valley Water Board to develop TMDLs for each 303(d) listed pollutant and water body combination. TMDLs have not been adopted for Clear Creek.

The Central Valley Water Board adopted a TMDL for diazinon in the Sacramento and Feather Rivers and amended the Basin Plan to include diazinon waste load allocations and water quality objectives on 16 October 2003, which applies to the Sacramento River from the Shasta Dam to the Colusa Basin Drain and its tributaries. On 3 May 2007, the Central Valley Water Board adopted Resolution No. R5 2007-0034, revising the water quality objectives and control program for diazinon originally adopted in 2003 and adding water quality objectives and a control program for chlorpyrifos. Effluent and receiving water monitoring data for diazinon and chlorpyrifos is not available. Monitoring for these constituents is required as part of the Effluent and Receiving Water Characterization Study required in section VI.C.2.d, as detailed in Attachment I. This Order may be reopened to include effluent limitations for diazinon and chlorpyrifos if monitoring data indicates reasonable potential to cause or contribute to an exceedance of the applicable Basin Plan water quality objectives.

- 3.** The 303(d) listings and TMDLs have been considered in the development of the Order. A pollutant-by-pollutant evaluation of each pollutant of concern is described in section IV.C.3. of this Fact Sheet.

E. Other Plans, Polices and Regulations

- 1. Title 27, California Code of Regulations (CCR), section 20005 et seq. (hereafter Title 27).** Title 27 contains regulations to address certain discharges to land. The Discharger utilizes three unlined settling basins to treat the filter backwash water which has the potential to be transported to underlying groundwater. Title 27, section 20090(b) contains an exemption for discharges of wastewater to land where the discharge is covered by WDRs, the discharge is in compliance with the Basin Plan, and the discharge does not need to be managed as a hazardous waste. Although there are no groundwater monitoring wells or domestic wells in the vicinity of the settling basins, the Central Valley Water Board finds that there is sufficient information to determine that constituents present in the settling basins are not transported to underlying groundwater and do not cause an exceedance of water quality objectives.

The discharge to the settling basins consists of incidental discharges from treatment and storage facilities associated with a water treatment plant, is regulated by waste discharge requirements consistent with applicable water quality objectives, and does not need to be managed as a hazardous waste. Raw water used at the Facility from Whiskeytown Dam also supplies all flows to Clear Creek. Therefore, the discharge characteristics are similar in nature to the water within the watershed. The chemical character of the raw water treated at the water treatment plant is of good quality. Aside from coagulants used in the treatment process, no other pollutants are added to the effluent and analyses of the effluent indicate a maximum electrical conductivity (EC) of 99 $\mu\text{mhos/cm}$ and pH between 6.6 and 7.9. The constituents of concern,

TENTATIVE DRAFT

including aluminum, iron, and manganese, are expected to settle out in the settling pond and are not expected to be discharged to groundwater. The settling ponds are located above shallow bedrock on a steep incline within 1,000 feet of Clear Creek. The groundwater gradient likely flows towards Clear Creek and thus installation of groundwater monitoring wells would be ineffective and unusable. Therefore, groundwater impacts should be insignificant and should not result in exceedance of water quality objectives. As discussed in Section IV.D.4.b of this Fact Sheet, this Order does not allow for an increase in flow or mass of pollutants to groundwater and the discharge is consistent with the antidegradation provisions of State Water Board Resolution No. 68-16. Therefore, the Central Valley Water Board finds that the settling basins meet the conditions for the Title 27 wastewater exemption.

IV. RATIONALE FOR EFFLUENT LIMITATIONS AND DISCHARGE SPECIFICATIONS

Effluent limitations and toxic and pretreatment effluent standards established pursuant to sections 301 (Effluent Limitations), 302 (Water Quality Related Effluent Limitations), 304 (Information and Guidelines), and 307 (Toxic and Pretreatment Effluent Standards) of the CWA and amendments thereto are applicable to the discharge.

The CWA mandates the implementation of effluent limitations that are as stringent as necessary to meet water quality standards established pursuant to state or federal law [33 U.S.C., §1311(b)(1)(C); 40 CFR 122.44(d)(1)]. NPDES permits must incorporate discharge limits necessary to ensure that water quality standards are met. This requirement applies to narrative criteria as well as to criteria specifying maximum amounts of particular pollutants. Pursuant to federal regulations, 40 CFR 122.44(d)(1)(i), NPDES permits must contain limits that control all pollutants that *“are or may be discharged at a level which will cause, have the reasonable potential to cause, or contribute to an excursion above any state water quality standard, including state narrative criteria for water quality.”* Federal regulations, 40 CFR 122.44(d)(1)(vi), further provide that *“[w]here a state has not established a water quality criterion for a specific chemical pollutant that is present in an effluent at a concentration that causes, has the reasonable potential to cause, or contributes to an excursion above a narrative criterion within an applicable State water quality standard, the permitting authority must establish effluent limits.”*

The CWA requires point source dischargers to control the amount of conventional, non-conventional, and toxic pollutants that are discharged into the waters of the United States. The control of pollutants discharged is established through effluent limitations and other requirements in NPDES permits. There are two principal bases for effluent limitations in the Code of Federal Regulations: 40 CFR 122.44(a) requires that permits include applicable technology-based limitations and standards; and 40 CFR 122.44(d) requires that permits include water quality-based effluent limitations (WQBELs) to attain and maintain applicable numeric and narrative water quality criteria to protect the beneficial uses of the receiving water where numeric water quality objectives have not been established. The Basin Plan at page IV-17.00, contains an implementation policy, *“Policy for Application of Water Quality Objectives”*, that specifies that the Central Valley Water Board *“will, on a case-by-case basis, adopt numerical limitations in orders which will implement the narrative objectives.”* This Policy complies with 40 CFR 122.44(d)(1). With respect to narrative objectives, the Central Valley Water Board must establish effluent limitations using one or

TENTATIVE DRAFT

more of three specified sources, including: (1) USEPA’s published water quality criteria, (2) a proposed state criterion (i.e., water quality objective) or an explicit state policy interpreting its narrative water quality criteria (i.e., the Central Valley Water Board’s “*Policy for Application of Water Quality Objectives*”)(40 CFR 122.44(d)(1)(vi)(A), (B) or (C)), or (3) an indicator parameter.

The Basin Plan includes numeric site-specific water quality objectives and narrative objectives for toxicity, chemical constituents, discoloration, radionuclides, and tastes and odors. The narrative toxicity objective states: “*All waters shall be maintained free of toxic substances in concentrations that produce detrimental physiological responses in human, plant, animal, or aquatic life.*” (Basin Plan at III-8.00) The Basin Plan states that material and relevant information, including numeric criteria, and recommendations from other agencies and scientific literature will be utilized in evaluating compliance with the narrative toxicity objective. The narrative chemical constituents objective states that waters shall not contain chemical constituents in concentrations that adversely affect beneficial uses. At minimum, “*...water designated for use as domestic or municipal supply (MUN) shall not contain concentrations of chemical constituents in excess of the maximum contaminant levels (MCLs)*” in Title 22 of CCR. The Basin Plan further states that, to protect all beneficial uses, the Central Valley Water Board may apply limits more stringent than MCLs. The narrative tastes and odors objective states: “*Water shall not contain taste- or odor-producing substances in concentrations that impart undesirable tastes or odors to domestic or municipal water supplies or to fish flesh or other edible products of aquatic origin, or that cause nuisance, or otherwise adversely affect beneficial uses.*”

A. Discharge Prohibitions

- 1. Prohibition III.A (Discharge of wastewater at a location or in a manner different from that described in the Findings is prohibited.)**. This prohibition is based on Water Code section 13260 that requires filing of a ROWD before discharges can occur. The Discharger submitted a ROWD for the discharges described in this Order; therefore, discharges not described in this Order are prohibited.
- 2. Prohibition III.B (The by-pass or overflow of wastes to surface waters is prohibited, except as allowed by Federal Standard Provisions I.G. and I.H.)**. As stated in section I.G of Attachment D, Standard Provisions, this Order prohibits bypass from any portion of the treatment facility. Federal regulations, 40 CFR 122.41(m), define “bypass” as the intentional diversion of waste streams from any portion of a treatment facility. This section of the federal regulations, 40 CFR 122.41(m)(4), prohibits bypass unless it is unavoidable to prevent loss of life, personal injury, or severe property damage. In considering the Central Valley Water Board’s prohibition of bypasses, the State Water Board adopted a precedential decision, Order No. WQO 2002-0015, which cites the federal regulations, 40 CFR 122.41(m), as allowing bypass only for essential maintenance to assure efficient operation.
- 3. Prohibition III.C (Neither the discharge nor its treatment shall create a nuisance as defined in section 13050 of the Water Code.)**. This prohibition is based on Water Code section 13050 that requires water quality objectives

TENTATIVE DRAFT

established for the prevention of nuisance within a specific area. The Basin Plan prohibits conditions that create a nuisance

4. **Prohibition III.D (The Discharger shall not allow pollutant-free wastewater to be discharged into the treatment or disposal system in amounts that significantly diminish the system’s capability to comply with this Order. Pollutant-free wastewater means rainfall, groundwater, cooling waters, and condensates that are essentially free of pollutants.)**. This prohibition is based on 40 CFR 122.41 et seq. that requires the proper design and operation of treatment facilities

B. Technology-Based Effluent Limitations

1. Scope and Authority

Section 301(b) of the CWA and implementing USEPA permit regulations at 40 CFR 122.44 require that permits include conditions meeting applicable technology-based requirements at a minimum, and any more stringent effluent limitations necessary to meet applicable water quality standards. The discharge authorized by this Order must meet minimum federal technology-based requirements based on Best Professional Judgment (BPJ) in accordance with 40 CFR 125.3.

The CWA requires that technology-based effluent limitations be established based on several levels of controls:

- a. Best practicable treatment control technology (BPT) represents the average of the best performance by plants within an industrial category or subcategory. BPT standards apply to toxic, conventional, and non-conventional pollutants.
- b. Best available technology economically achievable (BAT) represents the best existing performance of treatment technologies that are economically achievable within an industrial point source category. BAT standards apply to toxic and non-conventional pollutants.
- c. Best conventional pollutant control technology (BCT) represents the control from existing industrial point sources of conventional pollutants including BOD, TSS, fecal coliform, pH, and oil and grease. The BCT standard is established after considering the “cost reasonableness” of the relationship between the cost of attaining a reduction in effluent discharge and the benefits that would result, and also the cost effectiveness of additional industrial treatment beyond BPT.
- d. New source performance standards (NSPS) represent the best available demonstrated control technology standards. The intent of NSPS guidelines is to set limitations that represent state-of-the-art treatment technology for new sources.

The CWA requires USEPA to develop effluent limitations, guidelines and standards (ELGs) representing application of BPT, BAT, BCT, and NSPS. CWA section

TENTATIVE DRAFT

402(a)(1) and 40 CFR 125.3 authorize the use of best professional judgment (BPJ) to derive technology-based effluent limitations on a case-by-case basis where ELGs are not available for certain industrial categories and/or pollutants of concern. Where BPJ is used, the permit writer must consider specific factors outlined in 40 CFR 125.3.

2. Applicable Technology-Based Effluent Limitations

- a. **Flow.** The Facility was designed to provide treatment for up to a design flow of 1.5 MGD. Therefore, this Order contains a maximum daily discharge flow effluent limit of 1.5 MGD, consistent with Order No. R5-2006-0116.
- b. **TSS.** The Central Valley Water Board finds that TSS is more likely to be re-suspended than settleable solids in the settling ponds prior to discharge, and are therefore more likely to vary in the discharge than concentrations of settleable solids.

To establish limitations for TSS, the Central Valley Water Board examined several permits that regulate wastewater discharges from water treatment plants. A summary of these TSS limitations is presented in the table, below.

Table F-3. Summary of TSS Effluent Limitations in General Permits

State	General NPDES Permit No.	TSS Effluent Limitations (mg/L)		
		Average Monthly	Average Weekly	Maximum Daily
Arkansas	ARG640000	20	--	30
California (San Francisco Bay Region)	CAG382001	30	45	--
Massachusetts	MAG640000	30	--	50
New Hampshire	NHG640000	30	--	50
South Carolina	SCG646000	30	--	60
Washington	1	2	2	2
West Virginia	WV0115754	30	--	60

¹ General NPDES permit number not assigned.

² TSS is not limited.

The Central Valley Water Board also considered research performed for USEPA in 1987 (SAIC, Model Permit Package for the Water Supply Industry, EPA Contract No. 68-01-7043). This study found that 76 percent of water treatment plants surveyed used sedimentation lagoons for wastewater treatment. In these facilities, average monthly effluent limitations (AMELs) and maximum daily effluent limitations (MDELs) of 30 mg/L and 45 mg/L, respectively, were representative of the current permitting practice for TSS at that time. Analysis of actual monitoring data in the facilities studied showed the 95th percent occurrence (monthly average) and 99th percent occurrence (maximum daily) levels of treatment to be 28.1 mg/L and 44.4 mg/L, respectively. The study recommended limitations of 30 mg/L and 45 mg/L as the AMEL and MDEL, respectively, for a model NPDES permit.

Considering this information, the Central Valley Water Board established an AMEL and MDEL of 30 mg/L and 50 mg/L in Order No. R5-2006-0116 based on BPJ. These technology-based effluent limitations are retained in this Order.

**Summary of Technology-based Effluent Limitations
 Discharge Point No. 001**

Table F-4. Summary of Technology-based Effluent Limitations

Parameter	Units	Effluent Limitations			
		Average Monthly	Maximum Daily	Instantaneous Minimum	Instantaneous Maximum
Flow	MGD	--	1.5	--	--
Total Suspended Solids	mg/L	30	50	--	--

C. Water Quality-Based Effluent Limitations (WQBELs)

1. Scope and Authority

Section 301(b) of the CWA and 40 CFR 122.44(d) require that permits include limitations more stringent than applicable federal technology-based requirements where necessary to achieve applicable water quality standards.

40 CFR 122.44(d)(1)(i) mandates that permits include effluent limitations for all pollutants that are or may be discharged at levels that have the reasonable potential to cause or contribute to an exceedance of a water quality standard, including numeric and narrative objectives within a standard. Where reasonable potential has been established for a pollutant, but there is no numeric criterion or objective for the pollutant, WQBELs must be established using: (1) USEPA criteria guidance under CWA section 304(a), supplemented where necessary by other relevant information; (2) an indicator parameter for the pollutant of concern; or (3) a calculated numeric water quality criterion, such as a proposed state criterion or policy interpreting the state’s narrative criterion, supplemented with other relevant information, as provided in 40 CFR 122.44(d)(1)(vi).

The process for determining reasonable potential and calculating WQBELs when necessary is intended to protect the designated uses of the receiving water as specified in the Basin Plan, and achieve applicable water quality objectives and criteria that are contained in other state plans and policies, or any applicable water quality criteria contained in the CTR and NTR.

2. Applicable Beneficial Uses and Water Quality Criteria and Objectives

The Basin Plan designates beneficial uses, establishes water quality objectives, and contains implementation programs and policies to achieve those objectives for all waters addressed through the plan. In addition, the Basin Plan implements State Water Board Resolution No. 88-63, which established state policy that all waters,

TENTATIVE DRAFT

with certain exceptions, should be considered suitable or potentially suitable for municipal or domestic supply.

The Basin Plan on page II-1.00 states: *“Protection and enhancement of existing and potential beneficial uses are primary goals of water quality planning...”* and with respect to disposal of wastewaters states that *“...disposal of wastewaters is [not] a prohibited use of waters of the State; it is merely a use which cannot be satisfied to the detriment of beneficial uses.”*

The federal CWA section 101(a)(2), states: *“it is the national goal that wherever attainable, an interim goal of water quality which provides for the protection and propagation of fish, shellfish, and wildlife, and for recreation in and on the water be achieved by July 1, 1983.”* Federal Regulations, developed to implement the requirements of the CWA, create a rebuttable presumption that all waters be designated as fishable and swimmable. Federal Regulations, 40 CFR sections 131.2 and 131.10, require that all waters of the State regulated to protect the beneficial uses of public water supply, protection and propagation of fish, shell fish and wildlife, recreation in and on the water, agricultural, industrial and other purposes including navigation. Section 131.3(e), 40 CFR, defines existing beneficial uses as those uses actually attained after 28 November 1975, whether or not they are included in the water quality standards. Federal Regulation, 40 CFR section 131.10 requires that uses be obtained by implementing effluent limitations, requires that all downstream uses be protected and states that in no case shall a state adopt waste transport or waste assimilation as a beneficial use for any waters of the United States.

a. Receiving Water and Beneficial Uses

Beneficial uses applicable to Clear Creek are as follows:

Table F-5. Basin Plan Beneficial Uses

Discharge Point	Receiving Water Name	Beneficial Use(s)
001	Clear Creek	<u>Existing:</u> Municipal and domestic supply (MUN); Agricultural supply, including irrigation and stock watering (AGR); Water contact recreation, including canoeing and rafting (REC-1); Non-contact water recreation (REC-2); Warm freshwater habitat (WARM); Cold freshwater habitat (COLD); Migration of aquatic organisms, cold (MIGR); Spawning, reproduction, and/or early development, warm and cold (SPWN); and Wildlife habitat (WILD).
--	Groundwater	<u>Existing:</u> Municipal and domestic supply (MUN); Agricultural supply (AGR); Industrial service supply (IND); and Industrial process supply (PRO).

TENTATIVE DRAFT

In reviewing whether the existing and/or potential uses of Clear Creek are applicable, the Central Valley Water Board has considered the following facts:

i. Municipal and Domestic Supply and Agricultural Supply

The Central Valley Water Board is required to apply the beneficial uses of municipal and domestic supply to Clear Creek based on State Water Board Resolution No. 88-63 which was incorporated in the Basin Plan pursuant to Central Valley Water Board Resolution No. 89- 056. In addition, the State Water Board has issued water rights to existing water users along Clear Creek downstream of the discharge for domestic and irrigation uses. Clear Creek provides groundwater recharge. The groundwater is a source of drinking water. In addition to the existing water uses, growth in the area, downstream of the discharge is expected to continue, which presents a potential for increased domestic and agricultural uses of the water in Clear Creek.

ii. Water Contact and Noncontact Recreation and Esthetic Enjoyment

The Central Valley Water Board finds that the receiving water flows through residential areas, there is ready public access to Clear Creek, exclusion of the public is unrealistic and contact recreational activities currently exist along Clear Creek and downstream waters and these uses are likely to increase as the population in the area grows. Clear Creek flows through areas of general public access, meadows, residential areas, and parks. Clear Creek also offers recreational opportunities.

iii. Groundwater Recharge

In areas where groundwater elevations are below the stream bottom, water from the stream will percolate to groundwater.

iv. Freshwater Replenishment

Clear Creek has hydraulic continuity with the Sacramento River. Clear Creek adds to the water quantity and may impact the quality of water flowing in the Sacramento River.

v. Preservation and Enhancement of Fish, Wildlife, and Other Aquatic Resources

The California Department of Fish and Game (DFG) has verified that the fish species present in Clear Creek and downstream waters are consistent with both cold and warm water fisheries, that there is a potential for anadromous fish migration necessitating a cold water designation and that cold water species such as rainbow trout, Sacramento suckers, pike minnows, to name a few, have been found downstream of the water treatment plant. The Basin Plan (Table II-1) designates the Clear Creek as being both a cold and warm

TENTATIVE DRAFT

freshwater habitat. Therefore, pursuant to the Basin Plan (Table II-1, Footnote (2)), the cold designation applies to Clear Creek. The cold-water habitat designation necessitates that the in-stream dissolved oxygen concentration be maintained at, or above, 7.0 mg/L.

- b. Effluent and Ambient Background Data.** The reasonable potential analysis (RPA), as described in section IV.C.3 of this Fact Sheet, was based on data from June 2008 through May 2011, which includes effluent and ambient background data submitted in self-monitoring reports (SMRs) and the ROWD.
- c. Assimilative Capacity/Mixing Zone.** Clear Creek in the vicinity of the discharge is completely comprised of releases from Whiskeytown Lake. The rate of release from Whiskeytown Lake is variable, but occurs continuously year-round. Section 1.4.2 of the SIP allows for mixing zones and dilution credits in establishing effluent limitations. However, the Discharger has not provided an approved Dilution/Mixing Zone Study which meets the requirements of Section 1.4.2.2 of the SIP. Based on the available information, the worst-case dilution is assumed to be zero to provide protection for the receiving water beneficial uses. The impact of assuming zero assimilative capacity within the receiving water is that discharge limitations are end-of-pipe limits with no allowance for dilution within the receiving water. This Order includes a reopener to include effluent limitations based on an appropriate dilution factor if the Discharger submits and approved Dilution/Mixing Zone Study.
- d. Conversion Factors.** The CTR contains aquatic life criteria for arsenic, cadmium, chromium III, chromium VI, copper, lead, nickel, silver, and zinc which are presented in dissolved concentrations. USEPA recommends conversion factors to translate dissolved concentrations to total concentrations. The default USEPA conversion factors contained in Appendix 3 of the SIP were used to convert the applicable dissolved criteria to total recoverable criteria.
- e. Hardness-Dependent CTR Metals Criteria.** The *California Toxics Rule* and the *National Toxics Rule* contain water quality criteria for seven metals that vary as a function of hardness. The lower the hardness the lower the water quality criteria. The metals with hardness-dependent criteria include cadmium, copper, chromium III, lead, nickel, silver, and zinc.

This Order has established the criteria for hardness-dependent metals based on the reasonable worst-case ambient hardness as required by the SIP¹, the CTR² and State Water Board Order No. WQO 2008-0008 (City of Davis). The SIP and the CTR require the use of “receiving water” or “actual ambient” hardness, respectively, to determine effluent limitations for these metals. (SIP, § 1.2;

¹ The SIP does not address how to determine the hardness for application to the equations for the protection of aquatic life when using hardness-dependent metals criteria. It simply states, in Section 1.2, that the criteria shall be properly adjusted for hardness using the hardness of the receiving water.

² The CTR requires that, for waters with a hardness of 400 mg/L (as CaCO₃), or less, the actual ambient hardness of the surface water must be used. It further requires that the hardness values used must be consistent with the design discharge conditions for design flows and mixing zones.

40 CFR § 131.38(c)(4), Table 4, note 4.) The CTR does not define whether the term “ambient,” as applied in the regulations, necessarily requires the consideration of upstream as opposed to downstream hardness conditions. Therefore, where reliable, representative data are available, the hardness value for calculating criteria can be the downstream receiving water hardness, after mixing with the effluent (Order WQO 2008-0008, p. 11). The Central Valley Regional Water Board thus has considerable discretion in determining ambient hardness (*Id.*, p.10). Guidance on the selection of the appropriate ambient hardness was provided by the State Water Board in Order No. WQO 2008-0008 (City of Davis).

The State Water Board allows, where reliable, representative data are available, the hardness value for calculating criteria can be the downstream receiving water hardness, after mixing with the effluent. (Order WQO 2008-0008, p. 11.) Regional water boards have considerable discretion in determining ambient hardness as long as the hardness values are protective under all flow conditions. (*Id.*, pp. 10-11.)

As discussed below, scientific literature provides a reliable method for calculating protective hardness-dependent CTR criteria, considering all discharge conditions. This methodology produces hardness-dependent CTR criteria based on the reasonable worst-case downstream ambient hardness that ensure these metals do not cause receiving water toxicity under any downstream receiving water condition. Under this methodology, the Central Valley Water Board considers all hardness conditions that could occur in the ambient downstream receiving water after the effluent has mixed with the water body¹. This ensures that effluent limitations are fully protective of aquatic life in all areas of the receiving water affected by the discharge under all flow conditions, at the fully mixed location, and throughout the water body including at the point of discharge into the water body.

- i. **Conducting the Reasonable Potential Analysis (RPA).** The SIP in Section 1.3 states, “*The RWQCB shall...determine whether a discharge may: (1) cause, (2) have a reasonable potential to cause, or (3) contribute to an excursion above any applicable priority pollutant criterion or objective.*” Section 1.3 provides a step-by-step procedure for conducting the RPA. The procedure requires the comparison of the maximum effluent concentration maximum effluent concentration (MEC) and maximum ambient background concentration to the applicable criterion that has been properly adjusted for hardness. Unless otherwise noted, for the hardness-dependent CTR metals criteria the following procedures were followed for properly adjusting the criterion for hardness when conducting the RPA.

- (a) The SIP requires a WQBEL if the MEC exceeds the applicable criterion, adjusted for hardness. For comparing the MEC to the applicable criterion,

¹ All effluent discharges will change the ambient downstream metals concentration and hardness. It is not possible to change the metals concentration without also changing the hardness.

the “fully mixed” reasonable worst-case downstream ambient hardness was used to adjust the criterion. In this evaluation the portion of the receiving water affected by the discharge is analyzed. For hardness-dependent criteria, the hardness of the effluent has an impact on the determination of the applicable criterion in areas in the receiving water affected by the discharge. Therefore, for comparing the MEC to the applicable criterion, the reasonable worst-case downstream ambient hardness was used to adjust the criterion. For this situation it is necessary to consider the hardness of the effluent in determining the applicable hardness to adjust the criterion. The procedures for determining the applicable criterion after proper adjustment using the reasonable worst-case downstream hardness is outlined in subsection ii, below.

- (b) The SIP requires a WQBEL if the receiving water is impaired upstream (outside the influence) of the discharge, i.e., if the maximum ambient background concentration of a pollutant exceeds the applicable criterion, adjusted for hardness¹. For comparing the maximum ambient background concentration to the applicable criterion, the reasonable worst-case upstream ambient hardness was used to adjust the criteria. This is appropriate, because this area is outside the influence of the discharge. Since the discharge does not impact the upstream hardness, the effect of the effluent hardness was not included in this evaluation.
- ii. **Calculating Water Quality-Based Effluent Limitations.** The remaining discussion in this section relates to the development of WQBELs when it has been determined that the discharge has reasonable potential to cause or contribute to an exceedance of the CTR hardness-dependent metals criteria in the receiving water.

A 2006 Study² developed procedures for calculating the effluent concentration allowance (ECA)³ for CTR hardness-dependent metals. The 2006 Study demonstrated that it is necessary to evaluate all discharge conditions (e.g., high and low flow conditions) and the hardness and metals concentrations of the effluent and receiving water when determining the appropriate ECA for these hardness-dependent metals. This method is superior to relying on downstream receiving water samples alone because it captures all possible mixed conditions in the receiving water. Both receiving water and effluent hardness vary based on flow and other factors, but the variability of receiving water and effluent hardness is sometimes independent. Using a calculated hardness value ensures that the Central Valley Water Board considers all possible mixed downstream values that may result from

¹ The pollutant must also be detected in the effluent.

² Emerick, R.W.; Borroum, Y.; & Pedri, J.E., 2006. California and National Toxics Rule Implementation and Development of Protective Hardness Based Metal Effluent Limitations. WEFTEC, Chicago, Ill.

³ The ECA is defined in Appendix 1 of the SIP (page Appendix 1-2). The ECA is used to calculate WQBELs in accordance with Section 1.4 of the SIP.

these two independent variables. Relying on receiving water sampling alone is less likely to capture all possible mixed downstream conditions.

The equation describing the total recoverable regulatory criterion, as established in the CTR¹, is as follows:

$$\text{CTR Criterion} = \text{WER} \times (e^{m[\ln(H)]+b}) \quad (\text{Equation 1})$$

Where:

H = hardness (as CaCO₃)²

WER = water-effect ratio

m, b = metal- and criterion-specific constants

In accordance with the CTR, the default value for the WER is 1. A WER study must be conducted to use a value other than 1. The constants “m” and “b” are specific to both the metal under consideration, and the type of total recoverable criterion (i.e., acute or chronic). The metal-specific values for these constants are provided in the CTR at paragraph (b)(2), Table 1.

The equation for the ECA is defined in Section 1.4, Step 2, of the SIP and is as follows:

$$\text{ECA} = C \quad (\text{when } C \leq B)^3 \quad (\text{Equation 2})$$

Where:

C = the priority pollutant criterion/objective, adjusted for hardness (see Equation 1, above)

B = the ambient background concentration

The 2006 Study demonstrated that the relationship between hardness and the calculated criteria is the same for some metals, so the same procedure for calculating the ECA may be used for these metals. The same procedure can be used for chronic cadmium, chromium III, copper, nickel, and zinc. These metals are hereinafter referred to as “Concave Down Metals”. “Concave Down” refers to the shape of the curve represented by the relationship between hardness and the CTR criteria in Equation 1. Another similar procedure can be used for determining the ECA for acute cadmium, lead, and acute silver, which are referred to hereafter as “Concave Up Metals”.

ECA for Chronic Cadmium, Chromium III, Copper, Nickel, and Zinc – For Concave Down Metals (i.e., chronic cadmium, chromium III, copper, nickel, and zinc) the 2006 Study demonstrates that when the effluent is in

¹ 40 CFR § 131.38(b)(2).

² For this discussion, all hardness values are in mg/L as CaCO₃.

³ The 2006 Study assumes the ambient background metals concentration is equal to the CTR criterion (i.e., C ≤ B).

compliance with the CTR criteria and the upstream receiving water is in compliance with the CTR criteria, any mixture of the effluent and receiving water will always be in compliance with the CTR criteria¹. The 2006 Study proves that regardless of whether the effluent hardness is lower or greater than the upstream hardness, the reasonable worst-case flow condition is the effluent dominated condition (i.e., no receiving water flow)². Consequently, for Concave Down Metals, the CTR criteria have been calculated using the downstream ambient hardness under this condition.

The effluent hardness ranged from 30 mg/L to 51 mg/L, based on 10 samples from June 2008 through May 2011. The upstream receiving water hardness varied from 29 mg/L to 39 mg/L, based on seven samples from June 2008 through May 2011. Under the effluent dominated condition, the reasonable worst-case downstream ambient hardness is 30 mg/L. As demonstrated in the example shown in Table F-6, below, using this hardness to calculate the ECA for all Concave Down Metals will result in WQBELs that are protective under all flow conditions, from the effluent dominated condition to high flow condition. This example for zinc assumes the following conservative conditions for the upstream receiving water:

- Upstream receiving water always at the lowest observed upstream receiving water hardness (i.e., 29 mg/L)
- Upstream receiving water zinc concentration always at the CTR criteria (i.e., no assimilative capacity).

Using these reasonable worst-case receiving water conditions, a simple mass balance (as shown in Equation 3, below) accounts for all possible mixtures of effluent and receiving water under all flow conditions.

$$C_{MIX} = C_{RW} \times (1-EF) + C_{Eff} \times (EF) \quad \text{(Equation 3)}$$

Where:

- C_{MIX} = Mixed concentration (e.g. metals or hardness)
- C_{RW} = Upstream receiving water concentration
- C_{Eff} = Effluent concentration
- EF = Effluent Fraction

¹ 2006 Study, p. 5700.

² There are two typographical errors in the 2006 Study in the discussion of Concave Down Metals when the effluent hardness is less than the receiving water hardness. The effluent and receiving water hardness were transposed in the discussion, but the correct hardness values were used in the calculations. The typographical errors were confirmed by the author of the 2006 Study, by email dated 1 April 2011, from Dr. Robert Emerick to Mr. James Marshall, Central Valley Water Board.

In this example, for zinc, for any receiving water flow condition (high flow to low flow), the fully-mixed downstream ambient chromium III concentration is in compliance with the CTR criteria¹.

Table F-6. Chronic Zinc ECA Evaluation

		Lowest Observed Effluent Hardness		30 mg/L (as CaCO₃)	
		Lowest Observed Upstream Receiving Water Hardness		29 mg/L (as CaCO₃)	
		Highest Assumed Upstream Receiving Water Zinc Concentration		42 µg/L¹	
		Zinc ECA_{chronic}²		43 µg/L	
		Fully Mixed Downstream Ambient Concentration			
Effluent Fraction⁶		Hardness³ (mg/L)	CTR Criteria⁴ (µg/L)	Zinc⁵ (µg/L)	Complies with CTR Criteria
High Flow  Low Flow	1%	29	42	42	Yes
	5%	29	42	42	Yes
	15%	29	42	42	Yes
	25%	29	42	42	Yes
	50%	30	43	43	Yes
	75%	30	43	43	Yes
	100%	30	43	43	Yes

¹ Highest assumed upstream receiving water zinc concentration calculated using Equation 1 for chronic criterion at a hardness of 29 mg/L.
² ECA calculated using Equation 1 for chronic criterion at a hardness of 30 mg/L.
³ Fully mixed downstream ambient hardness is the mixture of the receiving water and effluent hardness at the applicable effluent fraction using Equation 3.
⁴ Fully mixed downstream ambient criteria are the chronic criteria calculated using Equation 1 at the mixed hardness.
⁵ Fully mixed downstream ambient zinc concentration is the mixture of the receiving water and effluent zinc concentrations at the applicable effluent fraction using Equation 3.
⁶ The effluent fraction ranges from 1% at the high receiving water flow condition, to 100% at the lowest receiving water flow condition (i.e., effluent dominated).

In some instances, the receiving water may already contain concentrations of concave down metals that exceed water quality criteria associated with the hardness condition previous to the discharge. The 2006 study procedures remain applicable under these conditions. The discharge cannot cause or contribute to a violation of water quality criteria/objectives in the receiving water. Although metals concentrations downstream of the discharge exceed CTR criteria, the cause of the exceedance is not due to the discharge, it is due to the elevated metals concentrations upstream of the discharge. Implementing the procedures of the 2006 study does not result in an increase in toxicity downstream of the discharge, and in fact reduces the amount of toxicity already present in the receiving water. This is demonstrated in the example below for copper (see Table F-7).

¹ This method considers the actual lowest upstream hardness and actual lowest effluent hardness to determine the reasonable worst-case ambient downstream hardness under all possible receiving water flow conditions. Table F-6 demonstrates that the receiving water is always in compliance with the CTR criteria at the fully-mixed location in the receiving water. It also demonstrates that the receiving water is in compliance with the CTR criteria for all mixtures from the point of discharge to the fully-mixed location. Therefore, a mixing zone is not used for compliance.

TENTATIVE DRAFT

Table F-7. Chronic Copper ECA Evaluation

		Lowest Observed Effluent Hardness			30 mg/L (as CaCO₃)
		Lowest Observed Upstream Receiving Water Hardness			29 mg/L (as CaCO₃)
		Highest Observed Upstream Receiving Water Copper Concentration			5.2 µg/L¹
		Copper ECA_{chronic}²			3.3 µg/L
		Fully Mixed Downstream Ambient Concentration			Percent Exceedance
		Hardness³ (mg/L)	CTR Criteria⁴ (µg/L)	Copper⁵ (µg/L)	
High Flow Low Flow	1%	29	3.2	5.2	60%
	5%	29	3.2	5.1	57%
	15%	29	3.3	4.9	51%
	25%	29	3.3	4.7	45%
	50%	30	3.3	4.3	30%
	75%	30	3.3	3.8	15%
	100%	30	3.3	3.3	0%

¹ Maximum observed upstream receiving water copper concentration.
² ECA calculated using Equation 1 for chronic criterion at a hardness of 30 mg/L.
³ Fully mixed downstream ambient hardness is the mixture of the receiving water and effluent hardness at the applicable effluent fraction using Equation 3.
⁴ Fully mixed downstream ambient criteria are the chronic criteria calculated using Equation 1 at the mixed hardness.
⁵ Fully mixed downstream ambient copper concentration is the mixture of the receiving water and effluent copper concentrations at the applicable effluent fraction using Equation 3.

ECA for Acute Cadmium, Lead, and Acute Silver – For Concave Up Metals (i.e., acute cadmium, lead, and acute silver), the relationship between hardness and the metals criteria is different than for Concave Down Metals. The 2006 Study demonstrates that for Concave Up Metals, the effluent and upstream receiving water can be in compliance with the CTR criteria, but the resulting mixture may contain metals concentrations that exceed the CTR criteria and could cause toxicity. For these metals, the 2006 Study provides a mathematical approach to calculate the ECA that is protective of aquatic life, in all areas of the receiving water affected by the discharge, under all discharge and receiving water flow (see Equation 4, below).

The ECA, as calculated using Equation 4, is based on the reasonable worst-case upstream receiving water hardness, the lowest observed effluent hardness, and assuming no receiving water assimilative capacity for metals (i.e., ambient background metals concentrations are at their respective CTR criterion). Equation 4 is not used in place of the CTR equation (Equation 1). Rather, Equation 4, which is derived using the CTR equation, is used as a direct approach for calculating the ECA. This replaces an iterative approach for calculating the ECA. The CTR equation has been used to evaluate the receiving water downstream of the discharge at all discharge and flow conditions to ensure the ECA is protective (e.g., see Table F-8).

TENTATIVE DRAFT

$$ECA \quad \gamma = \left(\frac{m(H_e - H_{rw}) \left(e^{m \ln(H_{rw}) + b} \right)}{H_{rw}} \right) + e^{m \ln(H_{rw}) + b} \quad \text{(Equation 4)}$$

Where:

- m, b = criterion specific constants (from CTR)
- H_e = minimum observed effluent hardness
- H_{rw} = reasonable worst-case upstream receiving water hardness

An example similar to the Concave Down Metals is shown for lead, a Concave Up Metal, in Table F-8, below. As previously mentioned, the lowest effluent hardness is 30 mg/L, while the upstream receiving water hardness ranged from 29 mg/L to 39 mg/L. In this case, the reasonable worst-case upstream receiving water hardness to use in Equation 4 to calculate the ECA is 39 mg/L.

Using the procedures discussed above to calculate the ECA for all Concave Up Metals will result in water quality-based effluent limitations that are protective under all potential effluent/receiving water flow conditions (high flow to low flow) and under all known hardness conditions, as demonstrated in Table F-8, for lead.

TENTATIVE DRAFT

Table F-8. Lead ECA Evaluation

		Lowest Observed Effluent Hardness			30 mg/L
		Reasonable Worst-case Upstream Receiving Water Hardness			39 mg/L
		Reasonable Worst-case Upstream Receiving Water Lead Concentration			0.66 µg/L¹
		Lead ECA_{chronic}²			0.68 µg/L
		Fully Mixed Downstream Ambient Concentration			
		Hardness³ (mg/L) (as CaCO₃)	CTR Criteria⁴ (µg/L)	Lead⁵ (µg/L)	Complies with CTR Criteria
High Flow Low Flow	1%	39	0.96	0.96	Yes
	5%	39	0.95	0.95	Yes
	15%	38	0.92	0.92	Yes
	25%	37	0.89	0.89	Yes
	50%	35	0.82	0.82	Yes
	75%	32	0.75	0.75	Yes
	100%	30	0.69	0.68	Yes

¹ Reasonable worst-case upstream receiving water lead concentration calculated using Equation 1 for chronic criterion at a hardness of 39 mg/L.

² ECA calculated using Equation 4 for chronic criteria.

³ Fully mixed downstream ambient hardness is the mixture of the receiving water and effluent hardness at the applicable effluent fraction.

⁴ Fully mixed downstream ambient criteria are the chronic criteria calculated using Equation 1 at the mixed hardness.

⁵ Fully mixed downstream ambient lead concentration is the mixture of the receiving water and effluent lead concentrations at the applicable effluent fraction.

⁶ The effluent fraction ranges from 1% at the high receiving water flow condition, to 100% at the lowest receiving water flow condition (i.e., effluent dominated).

Based on the procedures discussed above, Table F-9 lists all the CTR hardness-dependent metals and the associated ECA used in this Order.

Table F-9. Summary of ECA Evaluations for CTR Hardness-dependent Metals

CTR Metals	ECA (µg/L, total recoverable)	
	Acute	Chronic
Copper	†	3.3
Chromium III	648	77
Cadmium	†	0.96
Lead	17	0.68
Nickel	169	19
Silver	0.48	--
Zinc	†	43

[†] Per Footnote x for the acute criterion for cadmium, copper, and zinc in the CTR at 40 CFR 131.38(b)(1), the site-specific objectives for the Sacramento River above Hamilton City in Table III-1 of the Basin Plan applies in lieu of the acute CTR criterion.

3. Determining the Need for WQBELs

- a. The Central Valley Water Board conducted the RPA in accordance with section 1.3 of the SIP. Although the SIP applies directly to the control of CTR priority pollutants, the State Water Board has held that the Central Valley Water Board

TENTATIVE DRAFT

may use the SIP as guidance for water quality-based toxics control.¹ The SIP states in the introduction “*The goal of this Policy is to establish a standardized approach for permitting discharges of toxic pollutants to non-ocean surface waters in a manner that promotes statewide consistency.*” Therefore, in this Order the RPA procedures from the SIP were used to evaluate reasonable potential for both CTR and non-CTR constituents based on information submitted as part of the application, in studies, and as directed by monitoring and reporting programs.

b. Constituents with No Reasonable Potential. WQBELs are not included in this Order for constituents that do not demonstrate reasonable potential; however, monitoring for those pollutants is established in this Order as required by the SIP. If the results of effluent monitoring demonstrate reasonable potential, this Order may be reopened and modified by adding an appropriate effluent limitation.

i. Iron

(a) WQO. The Secondary MCL established for iron is 300 µg/L, used to implement the Basin Plan’s chemical constituent objective for the protection of municipal and domestic supply.

(b) RPA Results. The maximum annual average effluent and receiving water concentrations were used to evaluate reasonable potential to exceed the Secondary MCL based on input from the DPH and the fact that MCLs are designed to protect human health over long exposure periods. Therefore, it was considered appropriate to analyze reasonable potential based on an annual average concentration. The maximum observed annual average effluent concentration for iron was 261 µg/L. The maximum observed annual average upstream receiving water concentration was 80 µg/L. Therefore, the discharge does not demonstrate reasonable potential to cause or contribute to an in-stream excursion above the Basin Plan water quality objective for chemical constituents for iron.

ii. Salinity

(a) WQO. There are no USEPA water quality criteria for the protection of aquatic organisms for EC, total dissolved solids (TDS), sulfate, and chloride. The Basin Plan contains a chemical constituent objective that incorporates state MCLs, contains a narrative objective, and contains numeric water quality objectives for EC, TDS, sulfate, and chloride.

Table F-10. Salinity Water Quality Criteria/Objectives

Parameter	Agricultural WQ Goal ¹	Secondary MCL ³	Effluent	
			Average	Maximum
EC (µmhos/cm)	Varies ²	900, 1600, 2200	83	99
TDS (mg/L)	Varies	500, 1000, 1500	NA	NA
Sulfate (mg/L)	Varies	250, 500, 600	NA	NA

¹ See Order WQO 2001-16 (Napa) and Order WQO 2004-0013 (Yuba City).

Parameter	Agricultural WQ Goal ¹	Secondary MCL ³	Effluent	
			Average	Maximum
Chloride (mg/L)	Varies	250, 500, 600	2.65	2.7

NA – Not available

- ¹ Agricultural water quality goals based on *Water Quality for Agriculture*, Food and Agriculture Organization of the United Nations—Irrigation and Drainage Paper No. 29, Rev. 1 (R.S. Ayers and D.W. Westcot, Rome, 1985)
- ² The EC level in irrigation water that harms crop production depends on the crop type, soil type, irrigation methods, rainfall, and other factors. An EC level of 700 µmhos/cm is generally considered to present no risk of salinity impacts to crops. However, many crops are grown successfully with higher salinities.
- ³ The secondary MCLs are stated as a recommended level, upper level, and a short-term maximum level.

(1) Chloride. The Secondary MCL for chloride is 250 mg/L, as a recommended level, 500 mg/L as an upper level, and 600 mg/L as a short-term maximum. The recommended agricultural water quality goal for chloride, that would apply the narrative chemical constituent objective, is 106 mg/L as a long-term average based on *Water Quality for Agriculture*, Food and Agriculture Organization of the United Nations—Irrigation and Drainage Paper No. 29, Rev. 1 (R.S. Ayers and D.W. Westcot, Rome, 1985). The 106 mg/L water quality goal is intended to protect against adverse effects on sensitive crops when irrigated via sprinklers.

(2) Electrical Conductivity. The Secondary MCL for EC is 900 µmhos/cm as a recommended level, 1600 µmhos/cm as an upper level, and 2200 µmhos/cm as a short-term maximum. The agricultural water quality goal, that would apply the narrative chemical constituents objective, is 700 µmhos/cm as a long-term average based on *Water Quality for Agriculture*, Food and Agriculture Organization of the United Nations—Irrigation and Drainage Paper No. 29, Rev. 1 (R.S. Ayers and D.W. Westcot, Rome, 1985). The 700 µmhos/cm agricultural water quality goal is intended to prevent reduction in crop yield, i.e., a restriction on use of water, for salt-sensitive crops, such as beans, carrots, turnips, and strawberries. These crops are either currently grown in the area or may be grown in the future. Most other crops can tolerate higher EC concentrations without harm, however, as the salinity of the irrigation water increases, more crops are potentially harmed by the EC, or extra measures must be taken by the farmer to minimize or eliminate any harmful impacts.

(3) Sulfate. The Secondary MCL for sulfate is 250 mg/L as a recommended level, 500 mg/L as an upper level, and 600 mg/L as a short-term maximum.

(4) Total Dissolved Solids. The Secondary MCL for TDS is 500 mg/L as a recommended level, 1000 mg/L as an upper level, and 1500 mg/L as a short-term maximum. The recommended agricultural water quality

TENTATIVE DRAFT

goal for TDS, that would apply the narrative chemical constituent objective, is 450 mg/L as a long-term average based on Water Quality for Agriculture, Food and Agriculture Organization of the United Nations—Irrigation and Drainage Paper No. 29, Rev. 1 (R.S. Ayers and D.W. Westcot, Rome, 1985). Water Quality for Agriculture evaluates the impacts of salinity levels on crop tolerance and yield reduction, and establishes water quality goals that are protective of the agricultural uses. The 450 mg/L water quality goal is intended to prevent reduction in crop yield, i.e., a restriction on use of water, for salt-sensitive crops. Only the most salt sensitive crops require irrigation water of 450 mg/L or less to prevent loss of yield. Most other crops can tolerate higher TDS concentrations without harm, however, as the salinity of the irrigation water increases, more crops are potentially harmed by the TDS, or extra measures must be taken by the farmer to minimize or eliminate any harmful impacts.

(b) RPA Results.

- (1) Chloride.** The MEC for chloride was 2.7 mg/L, based on three samples collected in March through May 2011. Chloride was detected in the background receiving water at a concentration of 1.62 mg/L, based on three samples collected in March through May 2011. These levels do not exceed the agricultural water goal.
- (2) Electrical Conductivity.** A review of the Discharger's monitoring reports shows an average effluent EC of 83 μ mhos/cm, with a range from 69 μ mhos/cm to 99 μ mhos/cm. These levels do not exceed the agricultural water goal. Background receiving water data for EC is not available.
- (3) Sulfate.** Effluent and receiving water data for sulfate is not available.
- (4) Total Dissolved Solids.** Effluent and receiving water data for TDS is not available.

Based on the relatively low reported salinity, the discharge does not have reasonable potential to cause or contribute to an in-stream excursion of water quality objectives for salinity.

- c. Constituents with Limited Data.** Reasonable potential cannot be determined for the following constituents because effluent data are limited or ambient background concentrations are not available. The Discharger is required to continue to monitor for these constituents in the effluent using analytical methods that provide the best feasible detection limits. When additional data become available, further analysis will be conducted to determine whether to add numeric effluent limitations or to continue monitoring.

TENTATIVE DRAFT

i. Aluminum

(a) WQO. Aluminum is not a CTR constituent. The Basin Plan includes the narrative toxicity objective, which states that, *“All waters shall be maintained free of toxic substances in concentrations that produce detrimental physiological responses in human, plant, animal, or aquatic life.”* (Basin Plan at III-8.00) The Basin Plan’s *Policy for Application of Water Quality Objectives* requires the Central Valley Water Board to consider, *“on a case-by case basis, direct evidence of beneficial use impacts, all material and relevant information submitted by the discharger and other interested parties, and relevant numerical criteria and guidelines developed and/or published by other agencies and organizations. In considering such criteria, the Board evaluates whether the specific numerical criteria which are available through these sources and through other information supplied to the Board, are relevant and appropriate to the situation at hand and, therefore, should be used in determining compliance with the narrative objective.”* (Basin Plan, p. IV.-17.00; see also, 40 CFR 122.44(d)(vi).)

The Central Valley Water Board considered all available material and relevant information submitted by the Discharger, and relevant numerical criteria and guidelines developed and/or published by other agencies and organizations, the USEPA National Recommended Ambient Water Quality Criteria (NAWQC) and supporting studies, National Recommended Water Quality Criteria-Correction, the Arid West Water Quality Research Project and supporting studies, and site-specific aluminum studies conducted by other dischargers within the Central Valley Region in evaluating the appropriate criteria for protection of the beneficial uses to comply with the narrative toxicity objective.

USEPA developed the NAWQC for protection of freshwater aquatic life for aluminum. The recommended 4-day average (chronic) and 1-hour average (acute) criteria for aluminum are 87 µg/L and 750 µg/L, respectively, for waters with a pH of 6.5 to 9.0. The NAWQC chronic aquatic life criterion of 87 µg/L is based on studies conducted under conditions with low pH (6.5 – 6.6) and low hardness (<10 mg/L as CaCO₃) to determine the effects on striped bass and brook trout. During the 7-day long test with aluminum concentration averaged at 87 µg/L, no mortality occurred to 160 day old striped bass. This study, conducted with pH variations of 7.2 to 6.5 to 6.0 s.u., also indicated that pH variation has a large effect on aluminum toxicity.

In April 1999, USEPA released the National Recommended Water Quality Criteria-Correction. There were no corrections to the 1988 aluminum recommended criteria; however, USEPA recognized that they were aware of field data indicating that many high quality waters of the U.S. contain more than 87 µg/L aluminum, when either total recoverable or dissolved is measured (i.e., the higher levels of aluminum did not affect beneficial

uses). Information in Footnote L to the NAWQC Correction summary table for aluminum suggests the use of a WER may be appropriate in instances where water quality ambient conditions differ from those used by EPA.

As shown in the table below, monitoring data indicates that the water quality conditions for pH and hardness of the effluent and receiving water are not similar to the low pH and hardness conditions under which the aluminum chronic criterion of 87 µg/L was developed. Thus, although the Discharger has not conducted a site-specific WER study, it appears as if the NAWQC chronic criterion of 87 µg/L should not be used as the basis for determining compliance with the Basin Plan narrative toxicity objective and subsequently establishing effluent limitations for the discharge to Clear Creek.

Table F-11. Site-Specific pH and Hardness Characteristics

Parameter	Units	Test Conditions for Applicability of Chronic Criterion		Effluent	Receiving Water
		Striped Bass	Brook Trout		
pH	standard units	6.5	6.5 – 6.6	6.6 – 7.9	4.2 – 7.7
Hardness, Total (as CaCO ₃)	mg/L	<10	12.3	30 – 51	29 – 39
Aluminum, Total Recoverable	µg/L	87.2	88	29 – 139	20.2 – 98.8

Due to uncertainties with the NAWQC for aluminum, USEPA Region IX funded the Arid West Water Quality Research Project (“Arid West Project), which was established in 1995, under and Assistance Agreement between USEPA and Pima County Wastewater Management District. The Agreement allowed for research and recommendations of appropriate water quality criteria, standards and uses for effluent-dependent and ephemeral waters in the arid and semi-arid regions of the West, and to improve the scientific basis for regulating wastewater and storm water discharges in the arid and semi-arid West.

In May 2006, The Arid West Project produced its fifth in a series of research reports, *Evaluation of the EPA Recalculation Procedure in the Arid West Technical Report* (“Technical Report”). This Technical Report was to “to evaluate use of the [USEPA’s] Recalculation Procedure on selected water quality criteria with different modes of toxicity in specific arid and semi-arid West waters. In addition, a User’s Guide for Development of Site-Specific Water Quality Standards in Arid West Effluent-dependent Streams Using USEPA’s Recalculation Procedure was also prepared as a practical guide for water quality standards practitioners regarding use of the Recalculation Procedure for developing site-specific water quality standards.”

The Arid West Technical Report recalculated the NAWQC criterion based on more recent toxicological tests that provided a more updated, robust dataset for the recalculation. Use of this recalculated criterion can provide an indication of the expected relative toxicity of aluminum in similar geographic setting and water quality characteristics. Based on the

TENTATIVE DRAFT

methods in the Arid West Report, the recalculated chronic criterion for total aluminum for a mean hardness of 34 mg/L for Clear Creek is 371 µg/L and at the minimum hardness of 29 mg/L, the chronic criterion is 325 µg/L.

Additionally, site specific aluminum toxicity studies have also been conducted within Auburn Ravine (City of Auburn Aluminum Toxicity Study, November 2010) at pH and hardness characteristics that are similar to Clear Creek. The results of the Auburn Ravine aluminum site-specific toxicity studies, based on pH values from 6.6 to 7.5 and the hardness concentrations from 16 mg/L to 38 mg/L resulted in a calculated chronic aluminum water quality criterion of greater than 1,079 µg/L.

In comparison, based on similar water quality characteristics within the Central Valley Region (e.g., Clear Creek pH values from 4.2 to 7.7 s.u. and hardness concentration at 29 mg/L versus Auburn Ravine pH values from 6.6 to 7.5 s.u. and hardness concentration at 25 mg/L) the relevant aluminum numerical criteria ranges from 325 µg/L to 1,079 µg/L. Therefore, the Central Valley Water Board does not consider the NAWQC aluminum chronic criterion of 87 µg/L to be applicable to the water quality conditions of the receiving water. Instead, the site-specific numerical aluminum chronic criterion of 325 µg/L, based upon the Arid West recalculation method, is relevant and appropriate to use in determining compliance with the Basin Plan's narrative toxicity objective.

- (b) RPA Results.** The MEC for aluminum was 139 µg/L based on 14 samples collected between June 2008 and May 2011 and the maximum observed upstream receiving water concentration in Clear Creek was 98.8 µg/L based on three samples collected between March and May 2011

The Discharger uses poly-aluminum chloride (PAC) in the drinking water treatment process and this use may be a source of aluminum in the effluent. Aluminum may also be present in the source water. Based on the information above and the sampling results for aluminum, the discharge does not exceed the recalculated chronic criterion of 325 at the minimum hardness of 29 mg/L. In addition, based on the single sampling result the discharge does not have reasonable potential to exceed the Secondary MCL of 200 µg/L or the acute criterion of 750 µg/L.

This Order does not establish an effluent limitation for aluminum. However, since the Discharger uses aluminum in the treatment process, this Order requires the Discharger to continue effluent monitoring for aluminum sufficient to provide sufficient data for an RPA. If monitoring data indicates reasonable potential to exceed the criteria, this Order contains a re-opener provision for aluminum to establish an effluent limit if appropriate.

TENTATIVE DRAFT

ii. Bis (2-ethylhexyl) Phthalate

- (a) **WQO.** The CTR includes a criterion of 1.8 µg/L for bis (2-ethylhexyl) phthalate for the protection of human health for waters from which both water and organisms are consumed.
- (b) **RPA Results.** Bis (2-ethylhexyl) phthalate was detected in the effluent twice out of 12 monitoring events between June 2008 through May 2011 at concentrations of 0.9 µg/L and 2 µg/L. Bis (2-ethylhexyl) phthalate was not detected in one sample collected on 23 May 2011 in the upstream receiving water, which is also the raw water supply for the Facility. The Facility does use some plastic piping; however, it is unlikely for leaching from the piping to be detectable in the very large volumes of water constantly flowing through the Facility. The Facility uses polyaluminum chloride and a polymer in the water treatment system; however these additives have not been tested to verify if they are sources of bis (2-ethylhexyl) phthalate. Bis (2-ethylhexyl) phthalate is a common contaminant of sample containers, sampling apparatus, and analytical equipment, and sources of the detected bis (2-ethylhexyl) phthalate may be from plastics used for sampling or analytical equipment. Section 1.3, Step 8 of the SIP allows the Central Valley Water Board to require additional monitoring for a pollutant in place of an effluent limitation if data are unavailable or insufficient. Therefore, the Central Valley Water Board is not establishing effluent limitations for bis (2-ethylhexyl) phthalate at this time. Instead of limitations, additional monitoring has been established for bis (2-ethylhexyl) phthalate using “clean” techniques to ensure that sample containers, sampling apparatus, and analytical equipment are not sources of the detected pollutant. Additionally, this Order requires the Discharger to conduct a study to evaluate the source of bis (2-ethylhexyl) phthalate and monitoring sufficient to provide data to determine reasonable potential to exceed the CTR criterion. Should monitoring results indicate that the discharge has the reasonable potential to cause or contribute to an exceedance of a water quality standard, then this Order may be reopened and modified by adding an appropriate effluent limitation.

iii. Copper

- (a) Table III-1 of the Basin Plan contains a hardness-based water quality objective, expressed as a maximum concentration, for dissolved copper applicable to the Sacramento River and its tributaries above the State Highway 32 Bridge at Hamilton City. Using the minimum upstream receiving water hardness of 29 mg/L to determine the Basin Plan water quality objective, the applicable water quality objective for copper is 4.2 µg/L, as dissolved. Applying the acute conversion factor for copper of 0.96, the applicable water quality objective for copper is 4.4 µg/L, as total recoverable.

The CTR includes hardness-dependent acute and chronic criteria for the protection of freshwater aquatic life for copper. Footnote x for the acute criterion for copper in the CTR at 40 CFR 131.38(b)(1) states, “*The State of California has adopted and EPA has approved site specific criteria for the Sacramento River (and tributaries) above Hamilton City; therefore, these criteria do not apply to these waters.*” Thus, the acute CTR criterion for copper is not applicable. As described further in section IV.C.2.e of this Fact Sheet, the minimum observed effluent hardness was used to adjust the CTR criterion when comparing the MEC to the CTR chronic criterion and the minimum observed receiving water hardness was used when comparing the maximum background receiving water concentrations to the CTR chronic criterion. Using the default conversion factors and the minimum observed effluent hardness, the applicable chronic (4-day average) criterion for the effluent is 3.3 µg/L, as total recoverable. Using the default conversion factors and reasonable worst-case measured hardness of the receiving water, the applicable chronic (4-day average) criterion for the receiving water is 3.2 µg/L, as total recoverable.

(b) RPA Results. The MEC for copper was 1.5 µg/L (as total recoverable) while the maximum observed upstream receiving water concentration was 5.2 µg/L (as total recoverable), based on one sample collected on 23 May 2011. The effluent does not exceed the applicable criterion of 3.3 µg/L; however, the upstream receiving water does exceed the applicable criterion of 3.2 µg/L. The Facility does not use any chemicals that are expected to increase effluent copper concentrations. Section 1.3, Step 8 of the SIP allows the Central Valley Water Board to require additional monitoring for a pollutant in place of an effluent limitation if data are unavailable or insufficient. Due to the limited data set, the Central Valley Water Board is not establishing effluent limitations for copper at this time. Instead of limitations, additional monitoring has been established for copper. Additionally, this Order requires the Discharger to conduct a study to evaluate the source of copper and monitoring sufficient to provide data to determine reasonable potential to exceed the CTR criterion. Should monitoring results indicate that the discharge has the reasonable potential to cause or contribute to an exceedance of a water quality standard, then this Order may be reopened and modified by adding an appropriate effluent limitation.

d. Constituents with Reasonable Potential. The Central Valley Water Board finds that the discharge has a reasonable potential to cause or contribute to an in-stream excursion above a water quality standard for dichlorobromomethane, manganese, and pH. WQBELs for these constituents are included in this Order. WQBELs are also required for chlorine residual and settleable solids. A summary of the RPA is provided in Attachment G, and a detailed discussion of the RPA for each constituent is provided below.

iv. Chlorine Residual

- (a) **WQO.** USEPA developed NAWQC for protection of freshwater aquatic life for chlorine residual. The recommended 4-day average (chronic) and 1-hour average (acute) criteria for chlorine residual are 0.011 µg/L and 0.019 µg/L, respectively. These criteria are protective of the Basin Plan's narrative toxicity objective.
- (b) **RPA Results.** The Discharger adds chlorine to the raw water prior to the coagulation and filtration, which is extremely toxic to aquatic organisms. Due to the existing chlorine use and the possibility for chlorine to be discharged if an upset occurs or if the Facility is not operated properly, this Order establishes effluent limitations for chlorine residual.
- (c) **WQBELs.** The USEPA *Technical Support Document for Water Quality-Based Toxics Control* [EPA/505/2-90-001] contains statistical methods for converting chronic (4-day) and acute (1-hour) aquatic life criteria to average monthly and maximum daily effluent limitations based on the variability of the existing data and the expected frequency of monitoring. However, because chlorine is an acutely toxic constituent, an average 1-hour limitation is considered more appropriate than an average daily limitation. This Order contains a 4-day average effluent limitation and 1-hour average effluent limitation for chlorine residual of 0.011 µg/L and 0.019 µg/L, respectively, based on USEPA's NAWQC, which implements the Basin Plan's narrative toxicity objective for protection of aquatic life.
- (d) **Plant Performance and Attainability.** Chlorine residual was not detected in the effluent between June 2008 and May 2011. The Central Valley Water Board concludes, therefore, that immediate compliance with these effluent limitations is feasible.

v. Dichlorobromomethane

- (a) **WQO.** The CTR includes a criterion of 0.56 µg/L for dichlorobromomethane for the protection of human health for waters from which both water and organisms are consumed.
- (b) **RPA Results.** The MEC for dichlorobromomethane was 1.3 µg/L, while dichlorobromomethane was not detected in the upstream receiving water. Therefore, dichlorobromomethane in the discharge has a reasonable potential to cause or contribute to an in-stream excursion above the CTR criterion for the protection of human health.
- (c) **WQBELs.** This Order contains a final AMEL and MDEL for dichlorobromomethane of 0.56 µg/L and 1.2 µg/L, respectively, based on the CTR criterion for the protection of human health.

TENTATIVE DRAFT

(d) Plant Performance and Attainability. Analysis of the effluent data shows that the MEC of 1.3 µg/L is greater than applicable WQBELs. Based on the sample results for the effluent, the limitations appear to put the Discharger in immediate non-compliance. New or modified control measures may be necessary in order to comply with the effluent limitations, and the new or modified control measures cannot be designed, installed and put into operation within 30 calendar days. Furthermore, the effluent limitations for dichlorobromomethane are a new regulatory requirement within this permit, which becomes applicable to the waste discharge with the adoption of this Order, which was adopted after 1 July 2000. Therefore, a compliance time schedule for compliance with the dichlorobromomethane effluent limitations is established in TSO No. R5-2012-XXXX in accordance with Water Code section 13300, that requires preparation and implementation of a pollution prevention plan in compliance with Water Code section 13263.3.

vi. Manganese

(a) WQO. The Secondary MCL – Consumer Acceptance Limit for manganese is 50 µg/L, which is used to implement the Basin Plan’s chemical constituent objective for the protection of municipal and domestic supply.

(b) RPA Results. The maximum observed annual average effluent concentration for manganese was 314 µg/L, while the maximum observed annual average upstream receiving water concentration was 4.8 µg/L. Therefore, manganese in the discharge has a reasonable potential to cause or contribute to an in-stream excursion above the Secondary MCL.

(c) WQBELs. This Order contains an annual average effluent limitation for manganese of 50 µg/L based on the Basin Plan’s narrative chemical constituents objective and the Secondary MCL. Secondary MCLs are drinking water standards contained in Title 22 of the California Code of Regulations. For Secondary MCLs, Title 22 requires compliance with these standards on an annual average basis, when sampling at least quarterly. Since water that meets these requirements on an annual average basis is suitable for drinking, it is impracticable to calculate average weekly and average monthly effluent limitations because such limits would be more stringent than necessary to protect the MUN beneficial use. Central Valley Water Board has determined that an averaging period similar to what is used by the DPH for those parameters regulated by Secondary MCLs is appropriate, and that using shorter averaging periods is impracticable because it sets more stringent limits than necessary.

(d) Plant Performance and Attainability. Analysis of the effluent data shows that the maximum annual average effluent concentration of 283 µg/L is greater than applicable WQBEL. Based on the sample results

for the effluent, the limitation appears to put the Discharger in immediate non-compliance. New or modified control measures may be necessary in order to comply with the effluent limitation, and the new or modified control measures cannot be designed, installed and put into operation within 30 calendar days. Furthermore, the effluent limitation for manganese is a new regulatory requirement within this permit, which becomes applicable to the waste discharge with the adoption of this Order, which was adopted after 1 July 2000. Therefore, a compliance time schedule for compliance with the manganese effluent limitation is established in TSO No. R5-2012-XXXX in accordance with Water Code section 13300, that requires preparation and implementation of a pollution prevention plan in compliance with Water Code section 13263.3.

vii. pH

- (a) **WQO.** The Basin Plan includes a water quality objective for surface waters (except for Goose Lake) that the *“...pH shall not be depressed below 6.5 nor raised above 8.5.”*
- (b) **RPA Results.** Effluent pH ranged from 6.6 to 7.9. The discharge of settled filter backwash water and filter rinse water has a reasonable potential to cause or contribute to an excursion above the Basin Plan’s numeric objectives for pH.
- (c) **WQBELs.** Effluent limitations for pH of 6.5 as an instantaneous minimum and 8.5 as an instantaneous maximum are included in this Order based on protection of the Basin Plan objectives for pH.
- (d) **Plant Performance and Attainability.** The pH of the effluent ranged from 6.6 to 7.9 between June 2008 and May 2011. The Central Valley Water Board concludes, therefore, that immediate compliance with these effluent limitations is feasible.

viii. Settleable Solids

- (a) **WQO.** For inland surface waters, the Basin Plan states that *“[w]ater shall not contain substances in concentrations that result in the deposition of material that causes nuisance or adversely affects beneficial uses.”*
- (b) **RPA Results.** Settleable solids have the possibility of being discharged in the settled filter backwash water if an upset occurs or if the Facility is not operated properly. Therefore, this order establishes effluent limitations for settleable solids.
- (c) **WQBELs.** This Order contains an AMEL and MDEL for settleable solids. Because the amount of settleable solids is measured in terms of volume per volume without a mass component, it is impracticable to calculate mass limitations for inclusion in this Order. A daily maximum effluent

TENTATIVE DRAFT

limitation for settleable solids is included in the Order, in lieu of a weekly average, to ensure that the treatment works operate in accordance with design capabilities.

(d) Plant Performance and Attainability. Settleable solids were not detected in the effluent, based on monitoring conducted between June 2008 and May 2011. The Central Valley Water Board concludes, therefore, that immediate compliance with these effluent limitations is feasible.

4. WQBEL Calculations

- a. This Order includes WQBELs for chlorine residual, dichlorobromomethane, manganese, pH, and settleable solids. The general methodology for calculating WQBELs based on the different criteria/objectives is described in subsections IV.C.4.b through e, below. See Attachment H for the WQBEL calculations.
- b. **Effluent Concentration Allowance.** For each water quality criterion/objective, the ECA is calculated using the following steady-state mass balance equation from Section 1.4 of the SIP:

$$\begin{aligned} ECA &= C + D(C - B) && \text{where } C > B, \text{ and} \\ ECA &= C && \text{where } C \leq B \end{aligned}$$

where:

- ECA = effluent concentration allowance
- D = dilution credit
- C = the priority pollutant criterion/objective
- B = the ambient background concentration.

According to the SIP, the ambient background concentration (B) in the equation above shall be the observed maximum with the exception that an ECA calculated from a priority pollutant criterion/objective that is intended to protect human health from carcinogenic effects shall use the arithmetic mean concentration of the ambient background samples. For ECAs based on MCLs, which implement the Basin Plan's chemical constituents objective and are applied as annual averages, an arithmetic mean is also used for B due to the long-term basis of the criteria.

- c. **Basin Plan Objectives and MCLs.** For WQBELs based on site-specific numeric Basin Plan objectives or MCLs, the effluent limitations are applied directly as the ECA as either an MDEL, AMEL, or average annual effluent limitations, depending on the averaging period of the objective.
- d. **Aquatic Toxicity Criteria.** WQBELs based on acute and chronic aquatic toxicity criteria are calculated in accordance with Section 1.4 of the SIP. The ECAs are converted to equivalent long-term averages (i.e., LTA_{acute} and $LTA_{chronic}$) using

TENTATIVE DRAFT

statistical multipliers and the lowest LTA is used to calculate the AMEL and MDEL using additional statistical multipliers.

- e. **Human Health Criteria.** WQBELs based on human health criteria, are also calculated in accordance with Section 1.4 of the SIP. The ECAs are set equal to the AMEL and a statistical multiplier was used to calculate the MDEL.

$$AMEL = mult_{AMEL} \left[\min \left(\overbrace{M_A ECA_{acute}}^{LTA_{acute}}, M_C ECA_{chronic} \right) \right]$$

$$MDEL = mult_{MDEL} \left[\min \left(M_A ECA_{acute}, \underbrace{M_C ECA_{chronic}}_{LTA_{chronic}} \right) \right]$$

$$MDEL_{HH} = \left(\frac{mult_{MDEL}}{mult_{AMEL}} \right) AMEL_{HH}$$

where:

$mult_{AMEL}$ = statistical multiplier converting minimum LTA to AMEL

$mult_{MDEL}$ = statistical multiplier converting minimum LTA to MDEL

M_A = statistical multiplier converting acute ECA to LTA_{acute}

M_C = statistical multiplier converting chronic ECA to $LTA_{chronic}$

**Summary of Water Quality-Based Effluent Limitations
 Discharge Point No. 001**

Table F-12. Summary of Water Quality-Based Effluent Limitations

Parameter	Units	Effluent Limitations			
		Average Monthly	Maximum Daily	Instantaneous Minimum	Instantaneous Maximum
Conventional Pollutants					
pH	standard units	--	--	6.5	8.5
Priority Pollutants					
Dichlorobromomethane	µg/L	0.56	1.2	--	--
Non-Conventional Pollutants					
Chlorine, Total Residual	mg/L	0.011 ¹	0.019 ²	--	--
Manganese, Total Recoverable	µg/L	50 ³	--	--	--
Settleable Solids	ml/L	0.1	0.2	--	--

¹ Applied as a 4-day average effluent limitation.
² Applied as a 1-hour average effluent limitation.
³ Applied as an annual average effluent limitation.

TENTATIVE DRAFT

5. Whole Effluent Toxicity (WET)

For compliance with the Basin Plan’s narrative toxicity objective, this Order requires the Discharger to conduct whole effluent toxicity testing for acute and chronic toxicity, as specified in the Monitoring and Reporting Program (Attachment E section V.). This Order also contains effluent limitations for acute toxicity and requires the Discharger to implement best management practices to investigate the causes of, and identify corrective actions to reduce or eliminate effluent toxicity.

a. Acute Aquatic Toxicity. The Basin Plan contains a narrative toxicity objective that states, “*All waters shall be maintained free of toxic substances in concentrations that produce detrimental physiological responses in human, plant, animal, or aquatic life.*” (Basin Plan at page III-8.00) The Basin Plan also states that, “*...effluent limits based upon acute biotoxicity tests of effluents will be prescribed where appropriate...*”. USEPA Region 9 provided guidance for the development of acute toxicity effluent limitations in the absence of numeric water quality objectives for toxicity in its document titled "Guidance for NPDES Permit Issuance", dated February 1994. In section B.2. "Toxicity Requirements" (pgs. 14-15) it states that, "*In the absence of specific numeric water quality objectives for acute and chronic toxicity, the narrative criterion 'no toxics in toxic amounts' applies. Achievement of the narrative criterion, as applied herein, means that ambient waters shall not demonstrate for acute toxicity: 1) less than 90% survival, 50% of the time, based on the monthly median, or 2) less than 70% survival, 10% of the time, based on any monthly median. For chronic toxicity, ambient waters shall not demonstrate a test result of greater than 1 TUc.*" Based on annual acute toxicity testing, a minimum percent survival of 70 percent was observed, which occurred in January 2007. Consistent with Order No. R5-2006-0116, to ensure protection of aquatic life, effluent limitations for acute toxicity have been included in this Order as follows:

Acute Toxicity. Survival of aquatic organisms in 96-hour bioassays of undiluted waste shall be no less than:

Minimum for any one bioassay-----	70%
Median for any three consecutive bioassays -----	90%

b. Chronic Aquatic Toxicity. The Basin Plan contains a narrative toxicity objective that states, “*All waters shall be maintained free of toxic substances in concentrations that produce detrimental physiological responses in human, plant, animal, or aquatic life.*” (Basin Plan at page III-8.00) Based on chronic WET testing performed by the Discharger in May 2011, the discharge does not have reasonable potential to cause or contribute to an in-stream excursion above of the Basin Plan’s narrative toxicity objective.

Table F-13. Whole Effluent Chronic Toxicity Testing Results

Date	Fathead Minnow <i>Pimephales promelas</i>		Water Flea <i>Ceriodaphnia dubia</i>		Green Algae <i>Selenastrum capricornutum</i>
	Survival (Tuc)	Growth (Tuc)	Survival (Tuc)	Reproduction (Tuc)	Growth (Tuc)
24 May 2011	1	1	1	1	1

The Monitoring and Reporting Program of this Order requires chronic WET monitoring once during the third or fourth year of the permit term for demonstration of compliance with the narrative toxicity objective. In addition to WET monitoring, the Special Provision in section VI.C.2.a. of the Order requires the Discharger to submit to the Central Valley Water Board an Initial Investigative TRE Workplan for approval by the Executive Officer, to ensure the Discharger has a plan to immediately move forward with the initial tiers of a TRE, in the event effluent toxicity is encountered in the future. The provision also includes a numeric toxicity monitoring trigger, requirements for accelerated monitoring, and requirements for TRE initiation if toxicity is demonstrated.

Numeric chronic WET effluent limitations have not been included in this Order. The SIP contains implementation gaps regarding the appropriate form and implementation of chronic toxicity limits. This has resulted in the petitioning of a NPDES permit in the Los Angeles Region¹ that contained numeric chronic toxicity effluent limitations. To address the petition, the State Water Board adopted WQO 2003-012 directing its staff to revise the toxicity control provisions in the SIP. The State Water Board states the following in WQO 2003-012, *“In reviewing this petition and receiving comments from numerous interested persons on the propriety of including numeric effluent limitations for chronic toxicity in NPDES permits for publicly-owned treatment works that discharge to inland waters, we have determined that this issue should be considered in a regulatory setting, in order to allow for full public discussion and deliberation. We intend to modify the SIP to specifically address the issue. We anticipate that review will occur within the next year. We therefore decline to make a determination here regarding the propriety of the final numeric effluent limitations for chronic toxicity contained in these permits.”* The process to revise the SIP is currently underway. Proposed changes include clarifying the appropriate form of effluent toxicity limits in NPDES permits and general expansion and standardization of toxicity control implementation related to the NPDES permitting process. Since the toxicity control provisions in the SIP are under revision it is infeasible to develop numeric effluent limitations for chronic toxicity. Therefore, this Order requires that the Discharger meet best management practices for compliance with the Basin Plan’s narrative toxicity objective, as allowed under 40 CFR 122.44(k).

TENTATIVE DRAFT

¹ In the Matter of the Review of Own Motion of Waste Discharge Requirements Order Nos. R4-2002-0121 [NPDES No. CA0054011] and R4-2002-0123 [NPDES NO. CA0055119] and Time Schedule Order Nos. R4-2002-0122 and R4-2002-0124 for Los Coyotes and Long Beach Wastewater Reclamation Plants Issued by the California Regional Water Quality Control Board, Los Angeles Region SWRCB/OCC FILES A-1496 and 1496(a).

To ensure compliance with the Basin Plan’s narrative toxicity objective, the Discharger is required to conduct chronic WET testing, as specified in the Monitoring and Reporting Program (Attachment E section V.). Furthermore, the Special Provision contained at VI.C.2.a. of this Order requires the Discharger to investigate the causes of, and identify and implement corrective actions to reduce or eliminate effluent toxicity. If the discharge demonstrates toxicity exceeding the numeric toxicity monitoring trigger, the Discharger is required to initiate a Toxicity Reduction Evaluation (TRE) in accordance with an approved TRE workplan. The numeric toxicity monitoring trigger is not an effluent limitation; it is the toxicity threshold at which the Discharger is required to perform accelerated chronic toxicity monitoring, as well as, the threshold to initiate a TRE if effluent toxicity has been demonstrated.

D. Final Effluent Limitations

1. Mass-based Effluent Limitations

40 CFR 122.45(f)(1) requires effluent limitations be expressed in terms of mass, with some exceptions, and 40 CFR 122.45(f)(2) allows pollutants that are limited in terms of mass to additionally be limited in terms of other units of measurement. Pursuant to the exceptions to mass limitations provided in 40 CFR 122.45(f)(1), some effluent limitations are not expressed in terms of mass, such as pH and temperature, and when the applicable standards are expressed in terms of concentration (e.g., CTR criteria and MCLs) and mass limitations are not necessary to protect the beneficial uses of the receiving water.

2. Averaging Periods for Effluent Limitations

40 CFR 122.45 (d) requires maximum daily and average monthly discharge limitations for all dischargers other than publicly owned treatment works unless impracticable. The rationale for using alternative averaging periods for chlorine residual, pH, and manganese is discussed in section IV.C.3 of this Fact Sheet.

For effluent limitations based on Secondary MCLs this Order includes annual average effluent limitations. The Secondary MCLs are drinking water standards contained in Title 22 of the California Code of Regulations. Title 22 requires compliance with these standards on an annual average basis, when sampling at least quarterly. Since it is necessary to determine compliance on an annual average basis, it is impracticable to calculate average weekly and average monthly effluent limitations.

3. Satisfaction of Anti-Backsliding Requirements

The Clean Water Act specifies that a revised permit may not include effluent limitations that are less stringent than the previous permit unless a less stringent limitation is justified based on exceptions to the anti-backsliding provisions contained in Clean Water Act sections 402(o) or 303(d)(4), or, where applicable, 40 CFR

122.44(l). All effluent limitations in this Order are at least as stringent as the effluent limitations in the existing Order.

4. Satisfaction of Antidegradation Policy

- a. **Surface Water.** This Order does not allow for an increase in flow or mass of pollutants to the receiving water. Therefore, a complete antidegradation analysis is not necessary. The Order requires compliance with applicable federal technology-based standards and with WQBELs where the discharge could have the reasonable potential to cause or contribute to an exceedance of water quality standards. The permitted discharge is consistent with the antidegradation provisions of 40 CFR 131.12 and State Water Board Resolution No. 68-16. Compliance with these requirements will result in the use of best practicable treatment or control of the discharge. The impact on existing water quality will be insignificant.

- b. **Groundwater.** The Discharger utilizes three settling ponds. Filter backwash water from the water treatment process contains constituents such as TDS, EC, and metals. Percolation from the settling ponds may result in an increase in the concentration of these constituents in groundwater. The increase in the concentration of these constituents in groundwater must be consistent with Resolution No. 68-16. Any increase in pollutant concentrations in groundwater must be shown to be necessary to allow wastewater utility service necessary to accommodate housing and economic expansion in the area and must be consistent with maximum benefit to the people of the State of California. Some degradation of groundwater by the Discharger is consistent with Resolution No. 68-16 provided that:
 - i. the degradation is limited in extent;
 - ii. the degradation after effective source control, treatment, and control is limited to waste constituents typically encountered in municipal wastewater as specified in the groundwater limitations in this Order;
 - iii. the Discharger minimizes the degradation by fully implementing, regularly maintaining, and optimally operating best practicable treatment and control (BPTC) measures; and
 - iv. the degradation does not result in water quality less than that prescribed in the Basin Plan.

The discharge to the settling basins consists of incidental discharges from treatment and storage facilities associated with a water treatment plant. Raw water used at the Facility from Whiskeytown Dam also supplies all flows to Clear Creek. Therefore, the discharge characteristics are similar in nature to the water within the watershed. The chemical character of the raw water treated at the water treatment plant is of good quality. Aside from coagulants used in the treatment process, no other pollutants are added to the effluent and analyses of

TENTATIVE DRAFT

the effluent indicate a maximum electrical conductivity (EC) of 99 µmhos/cm and pH between 6.6 and 7.9. The constituents of concern, including aluminum, iron, and manganese, are expected to settle out in the settling pond and are not expected to be discharged to groundwater. The settling ponds are located above shallow bedrock on a steep incline within 1,000 feet of Clear Creek. The groundwater gradient likely flows towards Clear Creek and thus installation of groundwater monitoring wells would be ineffective and unusable. Therefore, groundwater impacts should be insignificant and should not result in exceedance of water quality objectives. This Order does not allow for an increase in flow or mass of pollutants to groundwater. Therefore, a complete antidegradation analysis is not necessary. The permitted discharge is consistent with the antidegradation provisions of State Water Board Resolution No. 68-16. Compliance with the requirements of this Order will result in the use of best practicable treatment or control of the discharge. The impact on existing water quality will be insignificant.

5. Stringency of Requirements for Individual Pollutants

This Order contains both technology-based effluent limitations and WQBELs for individual pollutants. The technology-based effluent limitations consist of restrictions on flow and TSS. The WQBELs consist of restrictions on chlorine residual, dichlorobromomethane, manganese, pH, and settleable solids. This Order’s technology-based pollutant restrictions implement the minimum, applicable federal technology-based requirements.

WQBELs have been scientifically derived to implement water quality objectives that protect beneficial uses. Both the beneficial uses and the water quality objectives have been approved pursuant to federal law and are the applicable federal water quality standards. To the extent that toxic pollutant WQBELs were derived from the CTR, the CTR is the applicable standard pursuant to 40 CFR 131.38. The scientific procedures for calculating the individual WQBELs for priority pollutants are based on the CTR-SIP, which was approved by USEPA on 18 May 2000. All beneficial uses and water quality objectives contained in the Basin Plan were approved under state law and submitted to and approved by USEPA prior to 30 May 2000. Any water quality objectives and beneficial uses submitted to USEPA prior to 30 May 2000, but not approved by USEPA before that date, are nonetheless “applicable water quality standards for purposes of the CWA” pursuant to 40 CFR 131.21(c)(1). Collectively, this Order’s restrictions on individual pollutants are no more stringent than required to implement the requirements of the CWA.

**Summary of Final Effluent Limitations
 Discharge Point No. 001**

Table F-14. Summary of Final Effluent Limitations

Parameter	Units	Effluent Limitations				Basis ¹
		Average Monthly	Maximum Daily	Instantaneous Minimum	Instantaneous Maximum	
Flow	MGD	--	1.5	--	--	DC

Parameter	Units	Effluent Limitations				Basis ¹
		Average Monthly	Maximum Daily	Instantaneous Minimum	Instantaneous Maximum	
Conventional Pollutants						
pH	standard units	--	--	6.5	8.5	BP
Total Suspended Solids	mg/L	30	50	--	--	BPJ
Priority Pollutants						
Dichlorobromomethane	µg/L	0.56	1.2	--	--	CTR
Non-Conventional Pollutants						
Chlorine, Total Residual	mg/L	0.011 ²	0.019 ³	--	--	NAWQC
Manganese, Total Recoverable	µg/L	50 ⁴	--	--	--	SEC MCL
Settleable Solids	ml/L	0.1	0.2	--	--	BP

¹ DC – Based on the design capacity of the Facility.
 BP – Based on water quality objectives contained in the Basin Plan.
 BPJ – Based on best professional judgment.
 CTR – Based on water quality criteria contained in the California Toxics Rule and applied as specified in the SIP.
 NAWQC – Based on USEPA’s National Ambient Water Quality Criteria for the protection of freshwater aquatic life.
 SEC MCL – Based on the Secondary Maximum Contaminant Level.
² Applied as a 4-day average effluent limitation.
³ Applied as a 1-hour average effluent limitation.
⁴ Applied as an annual average effluent limitation.

E. Interim Effluent Limitations – Not Applicable

F. Land Discharge Specifications – Not Applicable

G. Reclamation Specifications – Not Applicable

V. RATIONALE FOR RECEIVING WATER LIMITATIONS

Basin Plan water quality objectives to protect the beneficial uses of surface water and groundwater include numeric objectives and narrative objectives, including objectives for chemical constituents, toxicity, and tastes and odors. The toxicity objective requires that surface water and groundwater be maintained free of toxic substances in concentrations that produce detrimental physiological responses in humans, plants, animals, or aquatic life. The chemical constituent objective requires that surface water and groundwater shall not contain chemical constituents in concentrations that adversely affect any beneficial use or that exceed the maximum contaminant levels (MCLs) in Title 22, CCR. The tastes and odors objective states that surface water and groundwater shall not contain taste- or odor-producing substances in concentrations that cause nuisance or adversely affect beneficial uses. The Basin Plan requires the application of the most stringent objective necessary to ensure that surface water and groundwater do not contain chemical constituents, toxic substances, radionuclides, or taste and odor producing substances in concentrations that adversely affect domestic drinking water supply, agricultural supply, or any other beneficial use.

TENTATIVE DRAFT

A. Surface Water

1. CWA section 303(a-c), requires states to adopt water quality standards, including criteria where they are necessary to protect beneficial uses. The Central Valley Water Board adopted water quality criteria as water quality objectives in the Basin Plan. The Basin Plan states that “[t]he numerical and narrative water quality objectives define the least stringent standards that the Regional Water Board will apply to regional waters in order to protect the beneficial uses.” The Basin Plan includes numeric and narrative water quality objectives for various beneficial uses and water bodies. This Order contains receiving surface water limitations based on the Basin Plan numerical and narrative water quality objectives for bacteria, biostimulatory substances, color, chemical constituents, dissolved oxygen, floating material, oil and grease, pH, pesticides, radioactivity, suspended sediment, settleable substances, suspended material, tastes and odors, temperature, toxicity, and turbidity.
 - a. **pH.** Order No. R5-2006-0116 established a receiving water limitation for pH specifying that discharges from the Facility shall not cause the ambient pH to change by more than 0.5 units based on the water quality objective for pH in the Basin Plan. The Central Valley Water Board adopted Resolution No. R5-2007-0136 on 25 October 2007, amending the Basin Plan to delete the portion of the pH water quality objective that limits the change in pH to 0.5 units and the allowance of averaging periods for pH. The Basin Plan amendment has been approved by the State Water Board, the Office of Administrative Law, and USEPA. Consistent with the revised water quality objective in the Basin Plan, this Order does not require a receiving water limitation for pH change.

In Finding No. 14 of Resolution No. R5-2007-0136 the Central Valley Water Board found that the change in the pH receiving water objective is consistent with the State Water Board Resolution No. 68-16, in that the changes to water quality objectives (i) consider maximum benefit to the people of the State, (ii) will not unreasonably affect present and anticipated beneficial use of waters, and (iii) will not result in water quality less than that prescribed in policies, and is consistent with the federal Antidegradation Policy (40 CFR 131.12).

The relaxation of the pH receiving water limitation will protect aquatic life and other beneficial uses and will not unreasonably affect present and anticipated beneficial uses nor result in water quality less than described in applicable policies. The relaxation of the receiving water limitation is not expected to cause other impacts on water quality. The Central Valley Water Board finds that the relaxation of the pH receiving water limitation is to the maximum benefit to the people of the State, (ii) will not unreasonably affect present and anticipated beneficial use of waters, and (iii) will not result in water quality less than that prescribed in policies, and is consistent with the federal Antidegradation Policy (40 CFR 131.12).

The revised receiving water limitation for pH, which is based on the amendment to the Basin Plan’s pH water quality objective, reflects current scientifically

TENTATIVE DRAFT

supported pH requirements for the protection of aquatic life and other beneficial uses. The revised receiving water limitation for pH is more consistent with the current USEPA recommended criteria and is fully protective of aquatic life and the other beneficial uses listed in the Basin Plan. Changes in pH when pH is maintained within the range of 6.5 to 8.5 are neither beneficial nor adverse and, therefore, are not considered to be degradation in water quality. Attempting to restrict pH changes to 0.5 pH units would incur substantial costs without demonstrable benefits to beneficial uses. Thus, any changes in pH that would occur under the revised pH limitation would not only be protective of beneficial uses, but also would be consistent with maximum benefit to people of the State. Therefore the proposed amendment will not violate antidegradation policies.

- b. Turbidity.** Order No. R5-2006-0116 established a receiving water limitation for turbidity specifying that discharges from the Facility shall not cause the turbidity to increase more than 1 NTU where natural turbidity is between 0 and 5 NTU based on the water quality objective for turbidity in the Basin Plan. The Central Valley Water Board adopted Resolution No. R5-2007-0136 on 25 October 2007, amending the Basin Plan to limit turbidity to 2 NTU when the natural turbidity is less than 1 NTU. The Basin Plan amendment has been approved by the State Water Board, the Office of Administrative Law, and USEPA. Consistent with the revised water quality objective in the Basin Plan, this Order limits turbidity to 2 NTU when the natural turbidity is less than 1 NTU.

In Finding No. 14 of Resolution No. R5-2007-0136 the Central Valley Water Board found that the change in the turbidity receiving water objective is consistent with the State Water Board Resolution No. 68-16, in that the changes to water quality objectives (i) consider maximum benefit to the people of the State, (ii) will not unreasonably affect present and anticipated beneficial use of waters, and (iii) will not result in water quality less than that prescribed in policies, and is consistent with the federal Antidegradation Policy (40 CFR 131.12).

The relaxation of the turbidity receiving water limitation will protect aquatic life and other beneficial uses and will not unreasonably affect present and anticipated beneficial uses nor result in water quality less than described in applicable policies. The relaxation of the receiving water limitation is not expected to cause other impacts on water quality. The Central Valley Water Board finds that the relaxation of the turbidity receiving water limitation is to the maximum benefit to the people of the State, (ii) will not unreasonably affect present and anticipated beneficial use of waters, and (iii) will not result in water quality less than that prescribed in policies, and is consistent with the federal Antidegradation Policy (40 CFR 131.12).

The revised receiving water limitation for turbidity, which is based on the amendment to the Basin Plan's turbidity water quality objective, reflects current scientifically supported turbidity requirements for the protection of aquatic life and other beneficial uses and, therefore, will be fully protective of aquatic life and the other beneficial uses listed in the Basin Plan. Changes in turbidity allowed by the revised receiving water limitation, when ambient turbidity is below 1 NTU, would

TENTATIVE DRAFT

not adversely affect beneficial uses and would maintain water quality at a level higher than necessary to protect beneficial uses. Restricting low-level turbidity changes further may require costly upgrades, which would not provide any additional protection of beneficial uses. Thus, any changes in turbidity that would occur under the amended turbidity receiving water limitation would not only be protective of beneficial uses, but also would be consistent with maximum benefit to people of the State. Therefore, the relaxed receiving water limitations for turbidity will not violate antidegradation policies.

B. Groundwater

1. The beneficial uses of the underlying ground water are municipal and domestic supply, industrial service supply, industrial process supply, and agricultural supply.
2. Basin Plan water quality objectives include narrative objectives for chemical constituents, tastes and odors, and toxicity of groundwater. The toxicity objective requires that groundwater be maintained free of toxic substances in concentrations that produce detrimental physiological responses in humans, plants, animals, or aquatic life. The chemical constituent objective states groundwater shall not contain chemical constituents in concentrations that adversely affect any beneficial use. The tastes and odors objective prohibits taste- or odor-producing substances in concentrations that cause nuisance or adversely affect beneficial uses. The Basin Plan also establishes numerical water quality objectives for chemical constituents and radioactivity in groundwaters designated as municipal supply. These include, at a minimum, compliance with MCLs in Title 22 of the CCR. The bacteria objective prohibits coliform organisms at or above 2.2 MPN/100 mL. The Basin Plan requires the application of the most stringent objective necessary to ensure that waters do not contain chemical constituents, toxic substances, radionuclides, taste- or odor-producing substances, or bacteria in concentrations that adversely affect municipal or domestic supply, agricultural supply, industrial supply or some other beneficial use.
3. This Order retains the groundwater limitation from Order No. R5-2006-0116 to protect the beneficial uses of the underlying groundwater.

VI. RATIONALE FOR MONITORING AND REPORTING REQUIREMENTS

40 CFR 122.48 requires that all NPDES permits specify requirements for recording and reporting monitoring results. Water Code sections 13267 and 13383 authorizes the Central Valley Water Board to require technical and monitoring reports. The Monitoring and Reporting Program (Attachment E) of this Order, establishes monitoring and reporting requirements to implement federal and state requirements. The following provides the rationale for the monitoring and reporting requirements contained in the Monitoring and Reporting Program for the Facility.

TENTATIVE DRAFT

A. Influent Monitoring – Not Applicable

B. Effluent Monitoring

1. Pursuant to the requirements of 40 CFR 122.44(i)(2) effluent monitoring is required for all constituents with effluent limitations. Effluent monitoring is necessary to assess compliance with effluent limitations, assess the effectiveness of the treatment process, and to assess the impacts of the discharge on the receiving stream and groundwater.
2. Effluent monitoring frequencies and sample types for flow (continuous), pH (twice monthly), settleable solids (twice monthly), TSS (twice monthly), and electrical conductivity (quarterly) have been retained from Order No. R5-2006-0116 to characterize the effluent and determine compliance with effluent limitations for these parameters.
3. The Discharger adds chlorine gas to the raw water prior to the clarifier and filters. Although chlorine residual was not detected in the effluent during the permit term, this Order retains effluent limitations for chlorine residual due to the existing chlorine use and potential for chlorine to be discharged. Order No. R5-2006-0116 required daily monitoring. The Discharger indicated in the ROWD that a potential pond overflow scenario could result in discharges of chlorine. Under conditions when continuous backwashes are necessary to maintain filter performance, up to 1.7 million gallons of filter backwash water and up to 0.55 million gallons of filter rinse water could be discharged into the settling ponds. The total capacity of the settling ponds is 2.1 million gallons and the water level in any given pond is a function of its volume and season. Thus, under this scenario the total volume of 2.2 million gallons of filter backwash and filter rinse water would exceed the capacity of the ponds and overflow (through an overflow pipe rather than the normally controlled discharge through the floating outlets of the ponds). The Discharger estimates that this water could vary in chlorine residual between non-detect and 150 µg/L. However, the Discharger indicates that such an event is unlikely, has never occurred, and is not expected to occur. To date, the greatest number of filter backwashes required in one day is six, which occurred during a time of high turbidity caused by a mudslide into Whiskeytown Reservoir. This Order retains the daily monitoring requirements from Order No. R5-2006-0116 under normal operating conditions, but requires hourly sampling during periods of uncontrolled discharges from the ponds. The outlet decant system for the ponds is valved. The valves are typically closed on the weekends such that discharges to Clear Creek do not occur. Therefore, this Order requires the Discharger to monitor for chlorine prior to initiating discharges from the settling basins to Clear Creek to ensure that no detectable levels of chlorine are present in the effluent.
4. Monitoring data collected over the term of Order No. R5-2006-0116 for dichlorobromomethane and manganese indicates reasonable potential to cause or contribute to an exceedance of applicable water quality criteria and effluent limitations have been established in this Order. Therefore, monthly effluent

TENTATIVE DRAFT

monitoring for these constituents has been established in this Order to determine compliance with effluent limitations.

5. Monitoring data collected over the existing permit term for iron did not demonstrate reasonable potential to exceed water quality objectives/criteria. Thus, specific monitoring requirements for iron have not been retained from Order No. R5-2006-0016.
6. Order No. R5-2006-0116 required quarterly monitoring for aluminum. As discussed further in section IV.C.3.c.i of this Fact Sheet, the Discharger uses polyaluminum chloride in the treatment process. This Order requires the Discharger to continue quarterly effluent monitoring for aluminum to provide sufficient data for an RPA. If monitoring data indicates reasonable potential to exceed the criteria, this Order contains a re-opener provision for aluminum to establish an effluent limit if appropriate.
7. As discussed in section IV.C.3.c of this Fact Sheet, although there was a detection of bis (2-ethylhexyl) phthalate, due to the limited amount of data available and concerns with contamination from plastics in monitoring equipment, it is uncertain whether bis (2-ethylhexyl) phthalate is truly present in the effluent discharge. To collect the data necessary to determine the prevalence in the effluent, this Order establishes quarterly monitoring for bis (2-ethylhexyl) phthalate and requires the Discharger to conduct a constituent study to determine potential sources of bis (2-ethylhexyl) phthalate.
8. As discussed in section IV.C.3.c of this Fact Sheet, limited data is available to determine if copper is truly present in the effluent discharge at concentrations exceeding the applicable water quality criteria. To collect the data necessary to determine the prevalence in the effluent, this Order establishes quarterly monitoring for copper.
9. Monitoring data for mercury did not indicate reasonable potential to cause or contribute to an exceedance of water quality criteria for mercury. Clear Creek is listed on the 303(d) list as impaired for mercury. This Order requires effluent and receiving water monitoring for mercury.
10. This Order establishes monthly monitoring for hardness to ensure the water quality criteria for CTR hardness-based metals are correctly adjusted when conducting the RPA, as specified in section 1.3 of the SIP.
11. Priority pollutant data for the effluent has been provided by the Discharger over the term of Order No. R5-2006-0116, and was used to conduct a meaningful RPA. In accordance with Section 1.3 of the SIP, periodic monitoring for priority pollutants for which criteria or objectives apply and for which no effluent limitations have been established. This Order requires quarterly monitoring during the third or fourth year of the permit term in order to collect data to conduct an RPA for the next permit renewal. See Attachment I for more detailed requirements related to performing priority pollutant monitoring.

TENTATIVE DRAFT

12. California Water Code section 13176, subdivision (a), states: “*The analysis of any material required by [Water Code sections 13000-16104] shall be performed by a laboratory that has accreditation or certification to Article 3 (commencing with Section 100825) of Chapter 4 of Part 1 of Division 101 of the Health and Safety Code.*” The Department of Public Health certifies laboratories through its Environmental Laboratory Accreditation Program (ELAP).

Section 13176 cannot be interpreted in a manner that would violate federal holding time requirements that apply to NPDES permits pursuant to the Clean Water Act. (Wat. Code §§ 13370, subd. (c), 13372, 13377.) Section 13176 is inapplicable to NPDES permits to the extent it is inconsistent with Clean Water Act requirements. (Wat. Code § 13372, subd. (a).) The holding time requirements are 15 minutes for chlorine residual, dissolved oxygen, and pH and immediate analysis is required for temperature. (40 C.F.R. § 136.3(e), Table II) Due to the location of the Facility, it is both legally and factually impossible for the Discharger to comply with section 13176 for constituents with short holding times.

C. Whole Effluent Toxicity Testing Requirements

1. **Acute Toxicity.** Consistent with Order No. R5-2006-0116, annual 96-hour bioassay testing is required to demonstrate compliance with the effluent limitation for acute toxicity.
2. **Chronic Toxicity.** Consistent with Order No. R5-2006-0116, chronic whole effluent toxicity testing is required once during the third or fourth year of the permit term in order to demonstrate compliance with the Basin Plan’s narrative toxicity objective.

D. Receiving Water Monitoring

1. Surface Water

- a. Receiving water monitoring is necessary to assess compliance with receiving water limitations and to assess the impacts of the discharge on the receiving stream.
- b. This Order retains weekly receiving water monitoring requirements for pH and turbidity from Order No. R5-2006-0116.
- c. This Order increases the monitoring frequency for hardness from quarterly to monthly to ensure the water quality criteria for CTR hardness-based metals are correctly adjusted when conducting the RPA, as specified in section 1.3 of the SIP.
- d. Consistent with the effluent monitoring requirements, quarterly monitoring during the third or fourth year of the permit term for priority pollutants at Monitoring Location RSW-001 is required to collect the necessary data to determine reasonable potential as required in section 1.2 of the SIP. The hardness (as CaCO₃) of the upstream receiving water shall also be monitored concurrently

TENTATIVE DRAFT

with the priority pollutants as well as pH to ensure the water quality criteria/objectives are correctly adjusted for the receiving water when determining reasonable potential as specified in section 1.3 of the SIP. See Attachment I for more detailed requirements related to performing priority pollutant monitoring.

2. Groundwater – Not Applicable

E. Other Monitoring Requirements

1. **Pond Monitoring.** Monitoring of the settling ponds is required to ensure proper operation of the treatment ponds. Weekly monitoring for freeboard, dissolved oxygen, odors, pH, and electrical conductivity are established to determine compliance with the pond operating requirements in section VI.C.4.a. Quarterly monitoring for aluminum, bis (2-ethylhexyl) phthalate, and copper are required as part of the constituent studies required in sections IV.C.2.b and VI.C.2.c of this Order.
2. **Solids Monitoring.** Solids monitoring is required to ensure compliance with the solids disposal requirements of this Order and are retained from Order No. R5-2006-0116.

VII. RATIONALE FOR PROVISIONS

A. Standard Provisions

Standard Provisions, which apply to all NPDES permits in accordance with 40 CFR 122.41, and additional conditions applicable to specified categories of permits in accordance with 40 CFR 122.42, are provided in Attachment D. The discharger must comply with all standard provisions and with those additional conditions that are applicable under 40 CFR 122.42.

40 CFR 122.41(a)(1) and (b) through (n) establish conditions that apply to all State-issued NPDES permits. These conditions must be incorporated into the permits either expressly or by reference. If incorporated by reference, a specific citation to the regulations must be included in the Order. 40 CFR 123.25(a)(12) allows the state to omit or modify conditions to impose more stringent requirements. In accordance with 40 CFR 123.25, this Order omits federal conditions that address enforcement authority specified in 40 CFR 122.41(j)(5) and (k)(2) because the enforcement authority under the Water Code is more stringent. In lieu of these conditions, this Order incorporates by reference Water Code section 13387(e).

B. Special Provisions

1. Reopener Provisions

- a. **Mercury.** This provision allows the Central Valley Water Board to reopen this Order in the event mercury is found to be causing toxicity based on acute or chronic toxicity test results, or if a TMDL program is adopted. In addition, this

TENTATIVE DRAFT

Order may be reopened if the Central Valley Water Board determines that a mercury offset program is feasible for dischargers subject to NPDES permits.

- b. Whole Effluent Toxicity.** This Order requires the Discharger to investigate the causes of, and identify corrective actions to reduce or eliminate effluent toxicity through a TRE. This Order may be reopened to include a numeric chronic toxicity limitation, a new acute toxicity limitation, and/or a limitation for a specific toxicant identified in the TRE. Additionally, if a numeric chronic toxicity water quality objective is adopted by the State Water Board, this Order may be reopened to include a numeric chronic toxicity limitation based on that objective.
- c. Water Effects Ratio (WER) and Metal Translators.** A default WER of 1.0 has been used in this Order for calculating criteria for applicable inorganic constituents. In addition, default dissolved-to-total metal translators may be used to convert water quality objectives from dissolved to total recoverable when developing effluent limitations for copper if additional monitoring indicates that effluent limitations are necessary. If the Discharger performs studies to determine site-specific WERs and/or site-specific dissolved-to-total metal translators, this Order may be reopened to modify the effluent limitations for the applicable inorganic constituents.
- d. Constituent Study.** There are indications that the discharge may contain constituents that have a reasonable potential to cause or contribute to an exceedance of water quality objectives, including aluminum, bis (2-ethylhexyl) phthalate, and copper. This Order requires the Discharger to complete a study of these constituents' potential effect in the receiving water. This reopener provision allows the Central Valley Water Board to reopen this Order for addition of effluent limitations and requirements for these constituents if after review of the study results it is determined that the discharge has reasonable potential to cause or contribute to an exceedance of a water quality objective.

2. Special Studies and Additional Monitoring Requirements

- a. Chronic Whole Effluent Toxicity Requirements.** The Basin Plan contains a narrative toxicity objective that states, "*All waters shall be maintained free of toxic substances in concentrations that produce detrimental physiological responses in human, plant, animal, or aquatic life.*" (Basin Plan at page III-8.00.) Based on whole effluent chronic toxicity testing performed by the Discharger on 24 May 2011, the discharge does not have reasonable potential to cause or contribute to an in-stream excursion above of the Basin Plan's narrative toxicity objective.

The Monitoring and Reporting Program of this Order requires chronic WET monitoring for demonstration of compliance with the narrative toxicity objective. In addition to WET monitoring, this provision requires the Discharger to submit to the Central Valley Water Board an Initial Investigative TRE Workplan for approval by the Executive Officer, to ensure the Discharger has a plan to immediately move forward with the initial tiers of a TRE, in the event effluent toxicity is

encountered in the future. The provision also includes a numeric toxicity monitoring trigger, requirements for accelerated monitoring, and requirements for TRE initiation if toxicity is demonstrated.

Monitoring Trigger. A numeric toxicity monitoring trigger of > 1 TUc (where TUc = 100/NOEC) is applied in the provision, because this Order does not allow any dilution for the chronic condition. Therefore, a TRE is triggered when the effluent exhibits toxicity at 100% effluent.

Accelerated Monitoring. The provision requires accelerated WET testing when a regular WET test result exceeds the monitoring trigger. The purpose of accelerated monitoring is to determine, in an expedient manner, whether there is toxicity before requiring the implementation of a TRE. Due to possible seasonality of the toxicity, the accelerated monitoring should be performed in a timely manner, preferably taking no more than 2 to 3 months to complete.

The provision requires accelerated monitoring consisting of four chronic toxicity tests in a six-week period (i.e., one test every two weeks) using the species that exhibited toxicity. Guidance regarding accelerated monitoring and TRE initiation is provided in the *Technical Support Document for Water Quality-based Toxics Control*, EPA/505/2-90-001, March 1991 (TSD). The TSD at page 118 states, “EPA recommends if toxicity is repeatedly or periodically present at levels above effluent limits more than 20 percent of the time, a TRE should be required.” Therefore, four accelerated monitoring tests are required in this provision. If no toxicity is demonstrated in the four accelerated tests, then it demonstrates that toxicity is not present at levels above the monitoring trigger more than 20 percent of the time (only 1 of 5 tests are toxic, including the initial test). However, notwithstanding the accelerated monitoring results, if there is adequate evidence of effluent toxicity (i.e., toxicity present exceeding the monitoring trigger more than 20 percent of the time), the Executive Officer may require that the Discharger initiate a TRE.

See the WET Accelerated Monitoring Flow Chart (Figure F-1), below, for further clarification of the accelerated monitoring requirements and for the decision points for determining the need for TRE initiation.

TRE Guidance. The Discharger is required to prepare a TRE Workplan in accordance with USEPA guidance. Numerous guidance documents are available, as identified below:

- Toxicity Reduction Evaluation Guidance for Municipal Wastewater Treatment Plants, EPA/833-B-99/002, August 1999.
- Generalized Methodology for Conducting Industrial Toxicity Reduction Evaluations (TREs), EPA/600/2-88/070, April 1989.

TENTATIVE DRAFT

- Methods for Aquatic Toxicity Identification Evaluations: Phase I Toxicity Characterization Procedures, Second Edition, EPA 600/6-91/003, February 1991.
- Toxicity Identification Evaluation: Characterization of Chronically Toxic Effluents, Phase I, EPA/600/6-91/005F, May 1992.
- Methods for Aquatic Toxicity Identification Evaluations: Phase II Toxicity Identification Procedures for Samples Exhibiting Acute and Chronic Toxicity, Second Edition, EPA/600/R-92/080, September 1993.
- Methods for Aquatic Toxicity Identification Evaluations: Phase III Toxicity Confirmation Procedures for Samples Exhibiting Acute and Chronic Toxicity, Second Edition, EPA 600/R-92/081, September 1993.
- Methods for Measuring the Acute Toxicity of Effluents and Receiving Waters to Freshwater and Marine Organisms, Fifth Edition, EPA-821-R-02-012, October 2002.
- Short-term Methods for Estimating the Chronic Toxicity of Effluents and Receiving Waters to Freshwater Organisms, Fourth Edition, EPA-821-R-02-013, October 2002.
- Technical Support Document for Water Quality-based Toxics Control, EPA/505/2-90-001, March 1991.

TENTATIVE DRAFT

**Figure F-1
 WET Accelerated Monitoring Flow Chart**

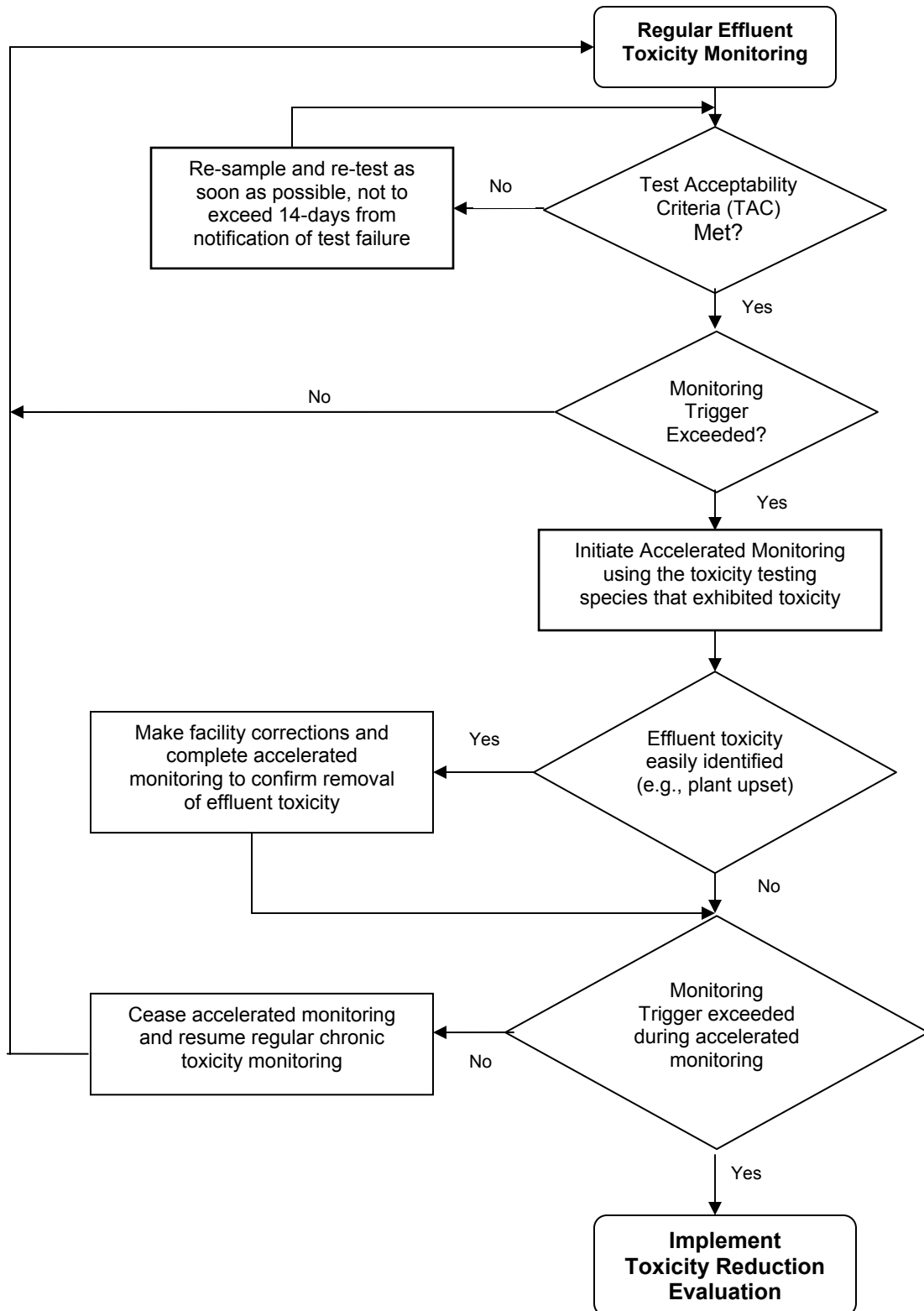

TENTATIVE DRAFT

- b. Constituent Study.** There are indications that the discharge may contain constituents that have a reasonable potential to cause or contribute to an exceedance of water quality objectives, including bis (2-ethylhexyl) phthalate and copper, as described further in section IV.C.3.c of this Fact Sheet. This Order requires the Discharger to complete a study to evaluate the source of these constituents and monitoring sufficient to provide data to determine reasonable potential to exceed the applicable criteria. If after a review of the study results it is determined that the discharge has reasonable potential to cause or contribute to an exceedance of a water quality objective this Order may be reopened and effluent limitations added for the subject constituents.
- c. Aluminum Study.** This Order requires the Discharger to conduct monitoring for aluminum as outlined in the Monitoring and Reporting Program (Attachment E). After review of the study results the Central Valley Water board will evaluate the recommendations, reevaluate reasonable potential for aluminum, and reopen the permit, if necessary, to include effluent limitations for aluminum.
- d. Effluent and Receiving Water Characterization Study.** This Order requires the Discharger to prepare an effluent and receiving water monitoring study to ensure adequate information is available for the next permit renewal.
- 3. Best Management Practices and Pollution Prevention – Not Applicable**
- 4. Construction, Operation, and Maintenance Specifications**

 - a. Pond Operating Requirements.** The operation and maintenance specifications are established to ensure proper operation of the settling ponds.
- 5. Special Provisions for Municipal Facilities (POTWs Only) – Not Applicable**
- 6. Other Special Provisions**

 - a. Sludge Disposal Requirements.** The Discharger submitted a 2006 Sludge Disposal Plan describing the Discharger’s sludge disposal practices. The Discharger periodically takes a pond out of service during the summer to permit solids to dry and allow removal. Sludge removed from the ponds is transported to the Shasta County landfill for disposal. This Order retains sludge disposal requirements from Order No. R5-2006-0116.
 - b. Low Threat Discharges.** Order No. R5-2006-0116 included effluent limitations, special provisions, and monitoring requirements for low threat discharges by the Discharger, such as well development water, construction dewatering, pump/well testing, pipeline/tank pressure testing, pipeline/tank flushing or dewatering, condensate discharges, unspecified water supply system discharges and other miscellaneous dewatering/low threat discharges. The Central Valley Water Board issued Order No. R5-2008-0081, *Waste Discharge Requirements for Dewatering and Other Low Threat Discharges* (General Order) on 12 June 2008. The General Order applies to individuals, public agencies, private businesses, and

TENTATIVE DRAFT

other legal entities discharging relatively pollutant-free wastewaters that pose little or no threat to the quality of surface waters, for a duration of either 4 months or less in duration or have an average dry weather flow less than 0.25 MGD. This Order does not apply to low threat discharges from the Facility and requires the Discharger to submit a Notice of Applicability (NOA) for coverage under Order No. R5-2008-0081 prior to discharging low threat wastewater.

7. Compliance Schedules – Not Applicable

VIII. PUBLIC PARTICIPATION

The Central Valley Water Board is considering the issuance of WDRs that will serve as an NPDES permit for the Facility. As a step in the WDR adoption process, the Central Valley Water Board staff has developed tentative WDRs. The Central Valley Water Board encourages public participation in the WDR adoption process.

A. Notification of Interested Parties

The Central Valley Water Board has notified the Discharger and interested agencies and persons of its intent to prescribe waste discharge requirements for the discharge and has provided them with an opportunity to submit their written comments and recommendations. Notification was provided through direct mailings and internet posting.

B. Written Comments

The staff determinations are tentative. Interested persons are invited to submit written comments concerning these tentative WDRs. Comments must be submitted either in person or by mail to the Executive Office at the Central Valley Water Board at the address above on the cover page of this Order.

To be fully responded to by staff and considered by the Central Valley Water Board, written comments must be received at the Central Valley Water Board offices by 5:00 p.m. on **16 February 2012**.

C. Public Hearing

The Central Valley Water Board will hold a public hearing on the tentative WDRs during its regular Board meeting on the following date and time and at the following location:

Date: 29/30 March 2012
Time: 8:30 a.m.
Location: Regional Water Quality Control Board, Central Valley Region
11020 Sun Center Dr., Suite #200
Rancho Cordova, CA 95670

Interested persons are invited to attend. At the public hearing, the Central Valley Water Board will hear testimony, if any, pertinent to the discharge, WDRs, and permit. Oral

TENTATIVE DRAFT

testimony will be heard; however, for accuracy of the record, important testimony should be in writing.

Please be aware that dates and venues may change. Our Web address is www.waterboards.ca.gov/centralvalley where you can access the current agenda for changes in dates and locations.

D. Waste Discharge Requirements Petitions

Any aggrieved person may petition the State Water Board to review the decision of the Central Valley Water Board regarding the final WDRs. The petition must be submitted within 30 days of the Central Valley Water Board’s action to the following address:

State Water Resources Control Board
Office of Chief Counsel
P.O. Box 100, 1001 I Street
Sacramento, CA 95812-0100

E. Information and Copying

The Report of Waste Discharge, related documents, tentative effluent limitations and special provisions, comments received, and other information are on file and may be inspected at the address above at any time between 8:30 a.m. and 4:45 p.m., Monday through Friday. Copying of documents may be arranged through the Central Valley Water Board by calling (916) 464-3291.

F. Register of Interested Persons

Any person interested in being placed on the mailing list for information regarding the WDRs and NPDES permit should contact the Central Valley Water Board, reference this Facility, and provide a name, address, and phone number.

G. Additional Information

Requests for additional information or questions regarding this order should be directed to Kevin Kratzke at (530) 224-4850.

TENTATIVE DRAFT

ATTACHMENT G – SUMMARY OF REASONABLE POTENTIAL ANALYSIS

Constituent	Units	MEC	B	C	CMC	CCC	Water & Org	Org. Only	Basin Plan	MCL	Reasonable Potential
Aluminum, Total Recoverable	µg/L	139	38.5	87	750 ¹	87 ²	--	--	--	200	No ³
Bis (2-ethylhexyl) Phthalate	µg/L	2	<0.9	1.8	--	--	1.8	5.9	--	4	No ³
Chloride	mg/L	3.2	1.62	106 ⁴	--	--	--	--	--	250	No
Copper, Total Recoverable	µg/L	1.5	5.2	3.3 ⁵ /3.2 ⁶	7	3.3 ⁵ /3.2 ⁶	--	1,300	4.4	1,000	No ³
Dichlorobromomethane	µg/L	1.3	<0.1	0.56	--	--	0.56	46	--	80	Yes
Electrical Conductivity @ 25°C	µg/L	99	NA	700 ⁴	--	--	--	--	--	900	No
Iron, Total Recoverable	µg/L	261 ⁸	79.5 ⁸	300	--	--	--	--	--	300	No
Manganese, Total Recoverable	µg/L	314 ⁸	4.8 ⁸	50	--	--	--	--	--	50	Yes
Mercury, Total Recoverable	µg/L	0.00196	0.00113	0.050	--	--	0.050	0.051	--	2	No

MEC = Maximum Effluent Concentration
 B = Maximum Receiving Water Concentration or lowest detection level, if non-detect
 C = Criterion used for Reasonable Potential Analysis
 CMC = Criterion Maximum Concentration (CTR or NTR)
 CCC = Criterion Continuous Concentration (CTR or NTR)
 Water & Org = Human Health Criterion for Consumption of Water & Organisms (CTR or NTR)
 Org. Only = Human Health Criterion for Consumption of Organisms Only (CTR or NTR)
 Basin Plan = Numeric Site-specific Basin Plan Water Quality Objective
 MCL = Drinking Water Standards Maximum Contaminant Level
 NA = Not Available
 ND = Non-detect

Footnotes:
 (1) USEPA National Recommended Ambient Water Quality Criteria, Freshwater Aquatic Life Protection, 1-hour Average
 (2) USEPA National Recommended Ambient Water Quality Criteria, Freshwater Aquatic Life Protection, 4-day Average
 (3) Reasonable potential cannot be determined for the pollutant because effluent data are limited or ambient background concentrations are not available. See section IV.C.3.c of the Fact Sheet (Attachment F).
 (4) Water Quality for Agriculture
 (5) Criterion to be compared to the maximum effluent concentration.
 (6) Criterion to be compared to the maximum upstream receiving water concentration.
 (7) Per Footnote x for the acute criterion for copper in the CTR at 40 CFR 131.38(b)(1), the site-specific objectives for the Sacramento River above Hamilton City in Table III-1 of the Basin Plan applies in lieu of the acute CTR criterion.
 (8) Represents the maximum observed annual average concentration for comparison with the MCL.

TENTATIVE DRAFT

ATTACHMENT H – CALCULATION OF WQBELS

Parameter	Units	Most Stringent Criteria			HH Calculations ¹			Aquatic Life Calculations ¹										Final Effluent Limitations		
		HH	CMC	CCC	ECA _{HH} = AMEL _{HH}	AMEL/MDEL Multiplier _{HH}	MDEL _{HH}	ECA _{acute}	ECA Multiplier _{acute}	LTA _{acute}	ECA _{chronic}	ECA Multiplier _{chronic}	LTA _{chronic}	Lowest LTA	AMEL Multiplier ₉₅	AMEL _{AL}	MDEL Multiplier ₉₉	MDEL _{AL}	Lowest AMEL	Lowest MDEL
Dichlorobromomethane	µg/L	0.56	--	--	0.56	2.20	1.2	--	--	--	--	--	--	--	--	--	--	--	0.56	1.2

¹ As described in section IV.C.2.c of the Fact Sheet (Attachment F), calculation of effluent limitations for the protection of human health and aquatic life are determined without the allowance of dilution credits.

TENTATIVE DRAFT

ATTACHMENT I – EFFLUENT AND RECEIVING WATER CHARACTERIZATION STUDY

- I. Background.** Sections 2.4.1 through 2.4.4 of the SIP provide minimum standards for analyses and reporting. (Copies of the SIP may be obtained from the State Water Resources Control Board, or downloaded from <http://www.waterboards.ca.gov/iswp/index.html>). To implement the SIP, effluent and receiving water data are needed for all priority pollutants. Effluent and receiving water pH and hardness are required to evaluate the toxicity of certain priority pollutants (such as heavy metals) where the toxicity of the constituents varies with pH and/or hardness. Section 3 of the SIP prescribes mandatory monitoring of dioxin congeners. In addition to specific requirements of the SIP, the Central Valley Water Board is requiring the following monitoring:
- A. Drinking water constituents.** Constituents for which drinking water Maximum Contaminant Levels (MCLs) have been prescribed in the California Code of Regulation are included in the *Water Quality Control Plan, Fourth Edition, for the Sacramento and San Joaquin River Basins* (Basin Plan). The Basin Plan defines virtually all surface waters within the Central Valley Region as having existing or potential beneficial uses for municipal and domestic supply. The Basin Plan further requires that, at a minimum, water designated for use as domestic or municipal supply shall not contain concentrations of chemical constituents in excess of the MCLs contained in the California Code of Regulations.
 - B. Effluent and receiving water temperature.** This is both a concern for application of certain temperature-sensitive constituents, such as fluoride, and for compliance with the Basin Plan’s thermal discharge requirements.
 - C. Effluent and receiving water hardness and pH.** These are necessary because several of the CTR constituents are hardness and pH dependent.
- II. Monitoring Requirements.**
- A. Semi-annual Monitoring.** Samples shall be collected from the effluent and upstream receiving water (Monitoring Locations EFF-001 and RSW-001) and analyzed for the constituents listed in Table I-1. Semi-annual monitoring shall be conducted for 1 year (two sampling events, evenly distributed throughout the year). The monitoring shall occur during the third year of the permit term and the results of such monitoring be submitted to the Central Valley Water Board upon completion. Each individual monitoring event shall provide representative sample results for the effluent and upstream receiving water.
 - B. Concurrent Sampling.** Effluent and receiving water sampling shall be performed at approximately the same time, on the same date.
 - C. Sample type.** All effluent samples shall be taken as 24-hour flow proportioned composite samples. All receiving water samples shall be taken as grab samples.

TENTATIVE DRAFT

Table I-1. Priority Pollutants and Other Constituents of Concern

CTR #	Constituent	CAS Number	Criterion Quantitation Limit µg/L or noted	Suggested Test Methods
28	1,1-Dichloroethane	75343	0.5	EPA 8260B
30	1,1-Dichloroethene	75354	0.5	EPA 8260B
41	1,1,1-Trichloroethane	71556	0.5	EPA 8260B
42	1,1,2-Trichloroethane	79005	0.5	EPA 8260B
37	1,1,2,2-Tetrachloroethane	79345	0.5	EPA 8260B
75	1,2-Dichlorobenzene	95501	0.5	EPA 8260B
29	1,2-Dichloroethane	107062	0.5	EPA 8260B
	cis-1,2-Dichloroethene	156592	0.5	EPA 8260B
31	1,2-Dichloropropane	78875	0.5	EPA 8260B
101	1,2,4-Trichlorobenzene	120821	0.5	EPA 8260B
76	1,3-Dichlorobenzene	541731	0.5	EPA 8260B
32	1,3-Dichloropropene	542756	0.5	EPA 8260B
77	1,4-Dichlorobenzene	106467	0.5	EPA 8260B
17	Acrolein	107028	2	EPA 8260B
18	Acrylonitrile	107131	2	EPA 8260B
19	Benzene	71432	0.5	EPA 8260B
20	Bromoform	75252	0.5	EPA 8260B
34	Bromomethane	74839	1	EPA 8260B
21	Carbon tetrachloride	56235	0.5	EPA 8260B
22	Chlorobenzene (mono chlorobenzene)	108907	0.5	EPA 8260B
24	Chloroethane	75003	0.5	EPA 8260B
25	2- Chloroethyl vinyl ether	110758	1	EPA 8260B
26	Chloroform	67663	0.5	EPA 8260B
35	Chloromethane	74873	0.5	EPA 8260B
23	Dibromochloromethane	124481	0.5	EPA 8260B
27	Dichlorobromomethane	75274	0.5	EPA 8260B
36	Dichloromethane	75092	0.5	EPA 8260B
33	Ethylbenzene	100414	0.5	EPA 8260B
88	Hexachlorobenzene	118741	1	EPA 8260B
89	Hexachlorobutadiene	87683	1	EPA 8260B
91	Hexachloroethane	67721	1	EPA 8260B
94	Naphthalene	91203	10	EPA 8260B
38	Tetrachloroethene	127184	0.5	EPA 8260B
39	Toluene	108883	0.5	EPA 8260B
40	trans-1,2-Dichloroethylene	156605	0.5	EPA 8260B

TENTATIVE DRAFT

CTR #	Constituent	CAS Number	Criterion Quantitation Limit µg/L or noted	Suggested Test Methods
43	Trichloroethene	79016	0.5	EPA 8260B
44	Vinyl chloride	75014	0.5	EPA 8260B
	Methyl-tert-butyl ether (MTBE)	1634044	0.5	EPA 8260B
	Trichlorofluoromethane	75694	5	EPA 8260B
	1,1,2-Trichloro-1,2,2-Trifluoroethane	76131	10	EPA 8260B
	Styrene	100425	0.5	EPA 8260B
	Xylenes	1330207	0.5	EPA 8260B
60	1,2-Benzanthracene	56553	5	EPA 8270C
85	1,2-Diphenylhydrazine	122667	1	EPA 8270C
45	2-Chlorophenol	95578	2	EPA 8270C
46	2,4-Dichlorophenol	120832	1	EPA 8270C
47	2,4-Dimethylphenol	105679	2	EPA 8270C
49	2,4-Dinitrophenol	51285	5	EPA 8270C
82	2,4-Dinitrotoluene	121142	5	EPA 8270C
55	2,4,6-Trichlorophenol	88062	10	EPA 8270C
83	2,6-Dinitrotoluene	606202	5	EPA 8270C
50	2-Nitrophenol	25154557	10	EPA 8270C
71	2-Chloronaphthalene	91587	10	EPA 8270C
78	3,3'-Dichlorobenzidine	91941	5	EPA 8270C
62	3,4-Benzofluoranthene	205992	10	EPA 8270C
52	4-Chloro-3-methylphenol	59507	5	EPA 8270C
48	4,6-Dinitro-2-methylphenol	534521	10	EPA 8270C
51	4-Nitrophenol	100027	5	EPA 8270C
69	4-Bromophenyl phenyl ether	101553	10	EPA 8270C
72	4-Chlorophenyl phenyl ether	7005723	5	EPA 8270C
56	Acenaphthene	83329	1	EPA 8270C
57	Acenaphthylene	208968	10	EPA 8270C
58	Anthracene	120127	10	EPA 8270C
59	Benzidine	92875	5	EPA 8270C
61	Benzo(a)pyrene (3,4-Benzopyrene)	50328	0.1	EPA 8270C
63	Benzo(g,h,i)perylene	191242	5	EPA 8270C
64	Benzo(k)fluoranthene	207089	2	EPA 8270C
65	Bis(2-chloroethoxy) methane	111911	5	EPA 8270C
66	Bis(2-chloroethyl) ether	111444	1	EPA 8270C
67	Bis(2-chloroisopropyl) ether	39638329	10	EPA 8270C
68	Bis(2-ethylhexyl) phthalate	117817	3	EPA 8270C

TENTATIVE DRAFT

CTR #	Constituent	CAS Number	Criterion Quantitation Limit µg/L or noted	Suggested Test Methods
70	Butyl benzyl phthalate	85687	10	EPA 8270C
73	Chrysene	218019	5	EPA 8270C
81	Di-n-butylphthalate	84742	10	EPA 8270C
84	Di-n-octylphthalate	117840	10	EPA 8270C
74	Dibenzo(a,h)-anthracene	53703	0.1	EPA 8270C
79	Diethyl phthalate	84662	2	EPA 8270C
80	Dimethyl phthalate	131113	2	EPA 8270C
86	Fluoranthene	206440	10	EPA 8270C
87	Fluorene	86737	10	EPA 8270C
90	Hexachlorocyclopentadiene	77474	1	EPA 8270C
92	Indeno(1,2,3-c,d)pyrene	193395	0.05	EPA 8270C
93	Isophorone	78591	1	EPA 8270C
98	N-Nitrosodiphenylamine	86306	1	EPA 8270C
96	N-Nitrosodimethylamine	62759	5	EPA 8270C
97	N-Nitrosodi-n-propylamine	621647	5	EPA 8270C
95	Nitrobenzene	98953	10	EPA 8270C
53	Pentachlorophenol	87865	0.2	EPA 8270C
99	Phenanthrene	85018	5	EPA 8270C
54	Phenol	108952	1	EPA 8270C
100	Pyrene	129000	10	EPA 8270C
	Aluminum	7429905	50	EPA 6020/200.8
1	Antimony	7440360	5	EPA 6020/200.8
2	Arsenic	7440382	0.01	EPA 1632
15	Asbestos	1332214	0.2 MFL >10um	EPA/600/R-93/116(PCM)
	Barium	7440393	100	EPA 6020/200.8
3	Beryllium	7440417	1	EPA 6020/200.8
4	Cadmium	7440439	0.25	EPA 1638/200.8
5a	Chromium (total)	7440473	2	EPA 6020/200.8
5b	Chromium (VI)	18540299	0.5	EPA 7199/1636
6	Copper	7440508	0.5	EPA 6020/200.8
14	Cyanide	57125	5	EPA 9012A
	Fluoride	7782414	0.1	EPA 300
	Iron	7439896	100	EPA 6020/200.8
7	Lead	7439921	0.5	EPA 1638
8	Mercury	7439976	0.0002 (11)	EPA 1669/1631
	Manganese	7439965	20	EPA 6020/200.8

TENTATIVE DRAFT

CTR #	Constituent	CAS Number	Criterion Quantitation Limit µg/L or noted	Suggested Test Methods
9	Nickel	7440020	5	EPA 6020/200.8
10	Selenium	7782492	5	EPA 6020/200.8
11	Silver	7440224	1	EPA 6020/200.8
12	Thallium	7440280	1	EPA 6020/200.8
	Tributyltin	688733	0.002	EV-024/025
13	Zinc	7440666	10	EPA 6020/200.8
110	4,4'-DDD	72548	0.02	EPA 8081A
109	4,4'-DDE	72559	0.01	EPA 8081A
108	4,4'-DDT	50293	0.01	EPA 8081A
112	alpha-Endosulfan	959988	0.02	EPA 8081A
103	alpha-Hexachlorocyclohexane (BHC)	319846	0.01	EPA 8081A
	Alachlor	15972608	1	EPA 8081A
102	Aldrin	309002	0.005	EPA 8081A
113	beta-Endosulfan	33213659	0.01	EPA 8081A
104	beta-Hexachlorocyclohexane	319857	0.005	EPA 8081A
107	Chlordane	57749	0.1	EPA 8081A
106	delta-Hexachlorocyclohexane	319868	0.005	EPA 8081A
111	Dieldrin	60571	0.01	EPA 8081A
114	Endosulfan sulfate	1031078	0.05	EPA 8081A
115	Endrin	72208	0.01	EPA 8081A
116	Endrin Aldehyde	7421934	0.01	EPA 8081A
117	Heptachlor	76448	0.01	EPA 8081A
118	Heptachlor Epoxide	1024573	0.01	EPA 8081A
105	Lindane (gamma-Hexachlorocyclohexane)	58899	0.019	EPA 8081A
119	PCB-1016	12674112	0.5	EPA 8082
120	PCB-1221	11104282	0.5	EPA 8082
121	PCB-1232	11141165	0.5	EPA 8082
122	PCB-1242	53469219	0.5	EPA 8082
123	PCB-1248	12672296	0.5	EPA 8082
124	PCB-1254	11097691	0.5	EPA 8082
125	PCB-1260	11096825	0.5	EPA 8082
126	Toxaphene	8001352	0.5	EPA 8081A
	Atrazine	1912249	1	EPA 8141A
	Bentazon	25057890	2	EPA 643/ 515.2
	Carbofuran	1563662	5	EPA 8318

TENTATIVE DRAFT

CTR #	Constituent	CAS Number	Criterion Quantitation Limit µg/L or noted	Suggested Test Methods
	2,4-D	94757	10	EPA 8151A
	Dalapon	75990	10	EPA 8151A
	1,2-Dibromo-3-chloropropane (DBCP)	96128	0.01	EPA 8260B
	Di(2-ethylhexyl)adipate	103231	5	EPA 8270C
	Dinoseb	88857	2	EPA 8151A
	Diquat	85007	4	EPA 8340/ 549.1/HPLC
	Endothal	145733	45	EPA 548.1
	Ethylene Dibromide	106934	0.02	EPA 8260B/504
	Glyphosate	1071836	25	HPLC/EPA 547
	Methoxychlor	72435	10	EPA 8081A
	Molinate (Ordram)	2212671	2	EPA 634
	Oxamyl	23135220	20	EPA 8318/632
	Picloram	1918021	1	EPA 8151A
	Simazine (Princep)	122349	1	EPA 8141A
	Thiobencarb	28249776	1	HPLC/EPA 639
16	2,3,7,8-TCDD (Dioxin)	1746016	5.00E-06	EPA 8290 (HRGC) MS
	2,4,5-TP (Silvex)	93765	1	EPA 8151A
	Diazinon	333415	0.25	EPA 8141A/GCMS
	Chlorpyrifos	2921882	1	EPA 8141A/GCMS
	Ammonia (as N)	7664417		EPA 350.1
	Chloride	16887006		EPA 300.0
	Flow			
	Hardness (as CaCO ₃)			EPA 130.2
	Foaming Agents (MBAS)			SM5540C
	Nitrate (as N)	14797558	2,000	EPA 300.0
	Nitrite (as N)	14797650	400	EPA 300.0
	pH		0.1	EPA 150.1
	Phosphorus, Total (as P)	7723140		EPA 365.3
	Specific conductance (EC)			EPA 120.1
	Sulfate		500	EPA 300.0
	Sulfide (as S)			EPA 376.2
	Sulfite (as SO ₃)			SM4500-SO3
	Temperature			
	Total Dissolved Solids (TDS)			EPA 160.1

TENTATIVE DRAFT

III. Additional Study Requirements

- A. Laboratory Requirements.** The laboratory analyzing the monitoring samples shall be certified by the Department of Health Services in accordance with the provisions of Water Code 13176 and must include quality assurance/quality control data with their reports (ELAP certified).
- B. Criterion Quantitation Limit (CQL).** The criterion quantitation limits will be equal to or lower than the minimum levels (MLs) in Appendix 4 of the SIP or the detection limits for purposes of reporting (DLRs) below the controlling water quality criterion concentrations summarized in Table I-1 of this Order. In cases where the controlling water quality criteria concentrations are below the detection limits of all approved analytical methods, the best available procedure will be utilized that meets the lowest of the MLs and DLR. Table I-1 contains suggested analytical procedures. The Discharger is not required to use these specific procedures as long as the procedure selected achieves the desired minimum detection level.
- C. Method Detection Limit (MDL).** The method detection limit for the laboratory shall be determined by the procedure found in 40 CFR Part 136, Appendix B (revised as of May 14, 1999).
- D. Reporting Limit (RL).** The reporting limit for the laboratory. This is the lowest quantifiable concentration that the laboratory can determine. Ideally, the RL should be equal to or lower than the CQL to meet the purposes of this monitoring.
- E. Reporting Protocols.** The results of analytical determinations for the presence of chemical constituents in a sample shall use the following reporting protocols:
1. Sample results greater than or equal to the reported RL shall be reported as measured by the laboratory (i.e., the measured chemical concentration in the sample).
 2. Sample results less than the reported RL, but greater than or equal to the laboratory's MDL, shall be reported as "Detected, but Not Quantified," or DNQ. The estimated chemical concentration of the sample shall also be reported.
 3. For the purposes of data collection, the laboratory shall write the estimated chemical concentration next to DNQ as well as the words "Estimated Concentration" (may shortened to "Est. Conc."). The laboratory, if such information is available, may include numerical estimates of the data quantity for the reported result. Numerical estimates of data quality may be percent accuracy (+ or – a percentage of the reported value), numerical ranges (low and high), or any other means considered appropriate by the laboratory.
 4. Sample results that are less than the laboratory's MDL shall be reported as "Not Detected" or ND.

TENTATIVE DRAFT

F. Data Format. The monitoring report shall contain the following information for each pollutant:

1. The name of the constituent.
2. Sampling location.
3. The date the sample was collected.
4. The time the sample was collected.
5. The date the sample was analyzed. For organic analyses, the extraction data will also be indicated to assure that hold times are not exceeded for prepared samples.
6. The analytical method utilized.
7. The measured or estimated concentration.
8. The required Criterion Quantitation Limit (CQL).
9. The laboratory's current Method Detection Limit (MDL), as determined by the procedure found in 40 CFR Part 136, Appendix B (revised as of May 14, 1999).
10. The laboratory's lowest reporting limit (RL).
11. Any additional comments.

TENTATIVE DRAFT