

2.0 Alternatives

DesertXpress Enterprises, LLC (Applicant) proposes to construct and operate an interstate high-speed passenger train between southern California and Las Vegas, Nevada along an approximately 200 mile corridor. The Applicant proposes to construct nearly all of the fully grade-separated, dedicated double track, passenger-only railroad either in the median or immediately alongside Interstate 15 (I-15). Limited portions of the proposed rail alignment would be located within existing railroad corridors or rights-of-way.¹

Alternatives evaluated and analyzed in this EIS include action alternatives for construction of the proposed steel wheel on steel rail high-speed train, and a “No Action” alternative.

The action alternatives considered in this EIS have been categorized into two primary sets: Alternative A and Alternative B. These are based on potential alignment routings for the 200 mile corridor. For analytical purposes in this EIS, each of the alignments is divided into segments. FRA’s intent in organizing the document in this manner is to allow for lead and cooperating agencies to “mix and match” various segments in composing a preferred alternative.

- **Alternative A** consists primarily of rail alignment segments that would be within the **median** of the I-15 freeway.
- **Alternative B** consists primarily of rail alignment segments that would be within the **fenced area** of the I-15 freeway, adjacent to automobile travel lanes.

The action alternatives would also include one of each of the following permanent physical facilities in addition to the rail alignment. As discussed below, this EIS examines multiple site options for these facilities. Similar to the consideration of rail segments noted above, FRA’s intent is to allow for the lead and cooperating agencies to compose their preferred alternative by incorporating one each of the following permanent physical facilities. With very few exceptions (noted in detailed discussions below), these physical facilities can connect to all rail alignment segments.

¹ The use of any private railroad rights-of-way would be subject to approval by owner railroads. STB approval of the Project would not convey the authority to force any private railroad to sell, lease, or otherwise allow DesertXpress to use the right-of-way of an existing railroad.

- **Victorville passenger station:** Two site options (Site 1 and Site 2) immediately west of the I-15 freeway are under consideration.
- **Victorville Operations, Maintenance, and Storage Facility (OMSF):** Two site options (OMSF 1 and OMSF 2) immediately west of the I-15 freeway are under consideration.
- **Maintenance of Way (MOW) facility:** One site option is under consideration adjacent to the I-15 freeway near the community of Baker.
- **Las Vegas area Maintenance and Storage Facility (MSF):** Three site options (Sloan Road MSF, Wigwam Avenue MSF, and Robindale Avenue MSF) are under consideration.
- **Las Vegas area passenger station:** Four site options are under consideration in Clark County/City of Las Vegas: Southern Station, Central Station A, Central Station B, and Downtown Station.

The Applicant has proposed two possible train technologies (referred to as “technology options”), each fully applicable to any set of the action alternatives: a diesel-electric multiple unit train (DEMU) or an electric multiple unit train (EMU). The two technology options would have similar right-of-way width requirements and largely the same construction footprint. However, the EMU option would also include overhead catenary wires and supports (located along the length of the rail alignment) three electrical substations (one at an OMSF, one at the MOW, and one at an MSF), and approximately seventeen transformers (each located on 4000 to 5000 square foot parcels at 10 mile intervals along the rail corridor). The EMU option would also require three electrical utility connections from the existing electrical grid, one in Victorville, one in Baker, and one near Sloan. Several train technologies for the DesertXpress project were considered but rejected from analysis in this EIS. Refer to Section 2.3.1, Train Technologies Considered but Rejected, for further discussion.

The estimated capital cost of any action alternative would be approximately \$3.5 to \$4 billion.

The alternative routings and physical facilities are illustrated in several graphics within this chapter and are described at length below. Preliminary engineering drawings of these components are included within Appendix A. Appendix A includes the following:

- **Appendix A-1:** Plan and profile drawings scale at 1 inch = 1,000 feet of the various rail alignment routings and ancillary facilities.
- **Appendix A-2:** Seven large-scale maps (each 36 inches by 48 inches) depicting the proposed rail segments and ancillary facilities at a large scale on maps features Township, Range, and Section detail from the Public Lands Survey System (PLSS).
- **Appendices A-3 and A-4:** Large sized site plans for proposed stations and maintenance facilities, identifying the proposed footprints of buildings,

tail tracks, fuel storage facilities, radio signal towers, power substations, and other related features.

- **Appendix A-5:** Plan drawings at 1"=1000' showing footprints of the 17 proposed autotransformers sites and typical autotransformer layout.

The remainder of this chapter is organized into the following sections:

- Section 2.1 gives a brief summary of alternatives considered;
- Section 2.2 describes the development of action alternatives;
- Section 2.3 discusses action alternatives and component options considered and dismissed from further analysis;
- Section 2.4 describes the location of the action alternatives and components including the technology, system-performance criteria, alignment, and station locations.

2.1 SUMMARY OF ALTERNATIVES

2.1.1 ACTION ALTERNATIVES

The action alternatives are subdivided into Alternative A alignments and Alternative B alignments, as well as seven segments within the alignments. Alternative A alignments are identified as the "Median Alternatives" in that from Yermo, California, northeasterly to Clark County/Las Vegas (Segments 3-7), the alignments would primarily be located within the median of the I-15 freeway. Action Alternative B alignments are identified as the "Right of Way Alternatives" in that for most of the distance between Victorville and Clark County/Las Vegas (Segments 1-7), the tracks would be located within or immediately adjacent to the right-of-way of I-15. Alternative A and B alignments would originate at one of the two Victorville station alternatives and terminate at one of the four Las Vegas station alternatives.

In addition, a third alignment option is offered for Segments 6 and 7, Option C. The Option C alignment would diverge from the I-15 corridor near the community of Sloan in unincorporated Clark County and generally follow, or be located within, the existing UPRR right-of-way. Option C would terminate at one of three Las Vegas station options, Central A, Central B or Downtown (one station option, the Southern Station, could not be utilized in conjunction with the Option C alignment).^{2 3}

The alignment options for the Action alternatives are summarized by segment in Table 2-1 below and illustrated in Figures 2-1.1 through 2-1.7.

² Option C would require approval by the Union Pacific Railroad (UPRR).

³ Station options are discussed in further detail below.

Table 2-1 Summary of Action Alternatives

Segment	Alternative A	Alternative B	Option C	Applicant's Proposal
1: Victorville to Lenwood	Segment 1: Along west side of I-15 corridor		NA	Segment 1
2: Lenwood to Yermo	Segment 2A/B, 2A Joint alignment through Barstow, then well north of I-15 past Yermo	Segment 2 A/B, 2B Joint alignment through Barstow, then just north of I-15 past Yermo	NA	Segment 2A/B, 2A
3: Yermo to Mountain Pass	Segment 3A: Within I-15 median	Segment 3B: West of I-15, running alongside freeway	NA	Segment 3B
4: Mountain Pass to Primm	Segment 4A: Includes approx. 2 mile portion of MNP, then east of I-15	Segment 4B: Through new tunnels in mountains northwest of I-15, through BLM-managed land	NA	Segment 4A
5: Primm to Sloan Road	Segment 5A: Within I-15 median	Segment 5B: Along east side of I-15	NA	Segment 5B
6: Sloan Road to Las Vegas (Southern or Central A/B Stations) ⁴	Segment 6A: Within I-15 median	Segment 6B: Varying from east to west side of I-15	Segment 6C: UPRR Corridor	Segment 6B
7: West Twain Avenue to Downtown Station	Segment 7A: Within I-15 median	Segment 7B: West side of I-15	Segment 7C: UPRR Corridor	Segment 7B

Alternative A alignments would provide median crossings for the segments located within the median of I-15 (Segments 3 through 7). For these portions, specifically between Yermo, California and Clark County/Las Vegas, the barriers and fencing along Alternative A Segments 3, 5, 6, and 7 would incorporate cross medians that would provide an opening for emergency access to the high-speed rail right-of-way. To provide access across the I-15 median for authorized emergency vehicles, such as Police, Fire, and Paramedics, Alternative A alignments would provide culverts under the railroad right-of-way for the exclusive use of emergency vehicles. In addition to the existing accessible highway overpasses and underpasses, the cross medians would be located approximately every 10 miles, or as required by the respective State Highway Patrols and state Departments of Transportation. Figure 2-2 shows the design concept of the cross median emergency access.

⁴ If Option C is selected for Segment 6, the terminus would be either Central Station A or B or the Downtown Station, via Segment 7A, 7B or Option C. Segment 6 Option C would not terminate at the Southern Station.

It is not anticipated that Alternative B would require the implementation of cross median emergency access, as Alternative B would be located alongside the existing I-15 freeway and within the I-15 right-of-way. As such, emergency access across the I-15 median would remain unaffected and no crossing of Alternative B would be necessary.

2.1.2 APPLICANT'S PROPOSED ALTERNATIVE

A significant portion of the project would lie within Federal lands administered by the BLM. As a Federal Cooperating Agency, the BLM required the Applicant to identify an "Applicant Proposed Alternative." The Applicant's Proposed Alternative, pending the results of the environmental analysis, is comprised of a mix of segments from Alternative A and B alignments. The Applicant's Proposed Alternative includes the following segments:

1: Victorville to Lenwood

2A/B, 2A: Lenwood to Yermo

3B: Yermo to Mountain Pass

4A: Mountain Pass to Primm via southerly alignment across Nipton Road

5B: Primm to Sloan

6B: Sloan to Southern, Central A, Central B Stations

7B: (Only if Downtown Station is selected) Twain Avenue to Downtown Station via I-15 corridor.

In terms of other physical facilities, the Applicant's Proposed Alternatives would utilize one of the two Victorville station sites, one of the two OMSF sites, the MOW site, one of the three MSF sites, and one of the four Las Vegas area passenger stations. If the EMU option is selected, then autotransformer sites and utility corridors would also be included. All of these components are analyzed in detail within Chapter 3 of this EIS.

2.1.3 NO ACTION ALTERNATIVE

The No Action Alternative would not involve the construction and operation of the high-speed train and associated facilities described above under the proposed Action Alternatives. The No Action Alternative is being studied as the baseline for comparison with the proposed action alternatives. The No Action Alternative would include existing access to Las Vegas via highway (I-15) and airport (McCarran International [LAS]) access. The No Action Alternative would analyze the system physical characteristics and capacity as they exist at the time of the EIS (2006-2009) and where possible, the planned and funded improvements that would be in place by the planning horizon year of 2030. These

are identified in Section 2.1.3.1 below. Other transportation improvements near Victorville and within Clark County are being studied and are not currently funded; as a result, these are not included in the baseline analysis for the No Action Alternative. These studies are discussed further in Section 2.1.3.2 below.

As of 2009, existing roadway conditions on I-15 from Victorville to Las Vegas are as follows:

Victorville to SR 58 (Barstow) - Three lanes each way with a 4th southbound truck lane coming out of Barstow up to the summit,

SR-58 to I-40 (Barstow) - Three lanes each way plus some auxiliary lanes,

I-40 to Baker - Two lanes each way

Baker to California/Nevada state line - Two lanes each way with a truck lane northbound approaching Halloran Summit (~17 miles north of Baker) and southbound at Mountain Pass (~15 miles south of the state line),

State line to I-215 - Three southbound lanes and two northbound lanes, with an additional northbound lane currently being constructed,

I-215 to Flamingo Road (Clark County) - Three lanes each way plus auxiliary lanes, and

North of Flamingo Road (Clark County and City of Las Vegas) - Four lanes each way.

Between 1995 and 2006, annual average daily traffic (AADT) at the California/Nevada state line rose steadily. Over these twelve years measured, AADT increased by 27 percent, at an average annual increase of about 2 percent. Over a typical year, travel demand is highest in the summer months of June, July, and August, and slightly above average in November and December. On a weekly basis, traffic volumes are heaviest on Sunday, followed by Friday and Saturday, with Monday-Thursday volumes markedly lower. The direction of traffic flow on I-15 is predominately southbound on Sunday and Monday, relatively even on Tuesday through Thursday, and predominately northbound on Friday and Saturday.

Under free flow traffic conditions, the trip on I-15 from Victorville to Las Vegas takes about 3 hours to travel the 192 mile distance, if driving the posted speed limit consistently. Recent studies estimated that the delay related to peak-period congestion was 1.25 hours in 2002, but will grow significantly, despite planned improvements. Delays associated with congestion are projected by Caltrans and FHWA to increase to 3.19 hours by 2012, 7.03 hours by 2022, and 5.78 hours by 2032, even with planned lane widening in place.⁵ With these projected travel delays, the total trip time from Victorville to Las Vegas would increase to more than 6 hours by 2012 and nearly 12 hours by 2032.

⁵ Initial Study/Environmental Assessment, Victorville to Barstow, Add Southbound Mixed Flow Lane. Caltrans, FHWA, County of San Bernardino, May 2001.

2.1.3.1 Planned and Programmed Transportation Improvements

While the No Action Alternative would not involve the construction of the DesertXpress high-speed rail system, Caltrans and the Nevada Department of Transportation (NDOT) are planning for future highway improvements along I-15 between Victorville and Las Vegas. Certain transportation improvements have been programmed for funding in a State Transportation Improvement Plan (TIP) or Long Range Transportation Plan (LRTP) or are otherwise understood to be reasonably foreseeable. For the purposes of this EIS, these planned transportation improvements are assumed to occur under both the No Action Alternative and the action alternatives by 2030. For a discussion of other planned projects that may occur in the project area but are not considered as part of the No Action Alternative nor the action alternatives, please refer to Chapter 1, Purpose and Need, Section 1.6, Relationship to Other Transportation Projects and Plans in the Study Area. These other planned projects are also considered in the cumulative analysis contained in this EIS in Chapter 3.16

As discussed in Section 2.0 of the Traffic Impact Study, I-15 will remain in its existing configuration for most of the distance between Victorville and Las Vegas, except for capacity improvements in the urban areas. The following improvements are anticipated to be operative within the No Action and action alternatives:

California

- Widen the bridge crossing over the Mojave River in Victorville
- Reconstruct the D Street, E Street, and South Stoddard Wells Road interchanges along I-15.
- Near Barstow, widen a 1-mile segment of I-15 to 6 lanes and reconstruct an I-15 interchange in Barstow.
- Add truck climbing lanes on I-15 in sections with steep grades.

Nevada

- “NEON” project:
 - Reconstruct the I-15/Charleston interchange,
 - Implement local access improvements
 - Add a High-Occupancy Vehicle (HOV) direct connector lane from US 95 to I-15.
- The “I-15 South” project (Sloan Road to Tropicana Avenue)

- Add new interchanges on I-15 at Bermuda Road, Starr Avenue, and Cactus Road.
- Reconstruct the Sloan Road and I-15 interchange.

2.1.3.2 Planned but Unprogrammed Transportation Improvements

Other transportation improvements near Victorville and within Clark County are anticipated but not currently funded, not found to be reasonably foreseeable, and were thus not taken into account in the traffic impact study for the DesertXpress project. These projects are however considered in the cumulative analysis contained in this EIS in Chapter 3.16.

In the Victorville area, planning is underway for the High Desert Corridor (HDC) roadway project. The HDC is a new regional highway that will eventually link Palmdale and Lancaster in the west to Apple Valley in the east. A twenty mile portion between US 395 in Adelanto (west of the project area) and SR-18, (east of the Town of Apple Valley) is under environmental review as of January 2009, expected to be complete the end of 2009. Completion of this portion of the project is anticipated by 2015.⁶

Furthermore, the City of Victorville is preparing a specific plan for the North Mojave area. The North Mojave area extends along I-15 from the Mojave River to the north of the Dale Evans Parkway interchange. However, planning work is not yet complete and the assumed roadway configuration within the North Mojave area is preliminary at this time.

NDOT has a planning study underway for potential upgrades to I-15 and parallel roadways between I-215 and US 95, referred to as the Urban Resort Corridor Study.

Clark County is considering a new airport in the Ivanpah Valley, just south of Las Vegas. The new airport would supplement the existing McCarran airport in Las Vegas. While specific site plans for the proposed Ivanpah airport are not yet complete, the new airport project has furthered the consideration of adding roadway capacity on the I-15 corridor, either through freeway widening and/or the construction of a new arterial roadway. Additionally, Clark County Department of Aviation is proposing the construction of the Southern Nevada Regional Heliport, which would be located near Sloan Road and I-15.

2.2 DEVELOPMENT OF ACTION ALTERNATIVES

The decisions of the Lead and Cooperating Agencies on the proposal are related to ensuring compliance with existing laws and regulations, permission to use federal lands, permission to form a new rail operating company, and permission to construct and

⁶ City of Victorville, High Desert Corridor Fact Sheet, Phase I, SR 18-T, accessed on February 3, 2009 at <http://ci.victorville.ca.us/uploadedFiles/CityServices/HighDesertCorridorFact%20Sheet.pdf>

operate a new rail line, including mitigation for all significant impacts. No Federal funds are currently sought for construction or operation of the proposal.

A decision to select the No Action Alternative would mean that the project would not be constructed. The Applicant has no obligation to entertain alternative transportation investments other than their proposed action.

A number of the alignment alternatives for the proposed project have been studied by the applicant. The applicant has removed some alternatives from further consideration based on technical and environmental criteria. Technical criteria were developed largely by the applicant and agreed to by the FRA. Environmental criteria were developed by FRA. This section describes the process used by the applicant to evaluate conceptual alignment alternatives and to make feasibility and practicability determinations in consultation with the FRA and cooperating agencies during the environmental review process. Key criteria used to distinguish among alternatives are listed in Table 2-2. Those criteria include technical and alignment factors, including connectivity, right-of-way constraints and compatibility, ridership potential, constructability, and environmental impacts. Agency criteria also included a review of project consistency with adopted plans and programs in effect in the project area and the minimization of any potential conflicts such as at-grade crossings of any roads, or conflicts with transportation purposes of the I-15 freeway corridor. Such criteria are used to screen the number of reasonable and practical potential alternatives, which are further reviewed against the technical criteria evaluated in Sections 3.1 through 3.16 of this EIS.

In addition, the FRA and cooperating agencies in the EIS process have developed criteria for consideration of alternatives. These are shown in Table 2-3.

Table 2-2 Alternatives Criteria

Technical and Alignment Criteria
Travel-time competitive with highway travel (1 hour and 45 minutes or less)
Reliable and convenient mode of travel
Proven steel wheel on steel track technology
Maximize return on investment for this privately funded project
Minimize the need for private land acquisition
Limited restrictions on track geometry for reduced travel time and increased passenger comfort
Maximum vertical gradient of 4.5% and maximum 6.0-inch actual super elevation (Ea)
Capable of accommodating normal maintenance activities without disruption to daily operations of adjacent highway or rail operations
Tunnels less than one mile in length
Adequate space for emergency access and maintenance and inspection access to the trackway
Adequate trackbed drainage
Able to provide acceptable horizontal clearance from existing and proposed railroad tracks, and existing and proposed highway lanes
Environmental Criteria
Minimize impacts to parklands, including the Mojave National Preserve
Minimize impacts to known cultural resources, wetlands, habitat area for threatened and endangered species, nature preserves
Minimize the relocation of residences and commercial properties
Minimize noise to residential properties and sensitive receptors
Maximize connectivity with other transportation modes, including airports, monorail, and bus routes
Maximize ridership and mode shift from auto to improve air quality, energy use and safety along I-15 corridor.

Table 2-3 Federal Agency Alternatives Criteria

Alternatives Criteria
Consistent with goals and objectives of approved policies and plans
Minimize conflicts while preserving safety and efficiency of existing highways and railroads
Minimize significant effects to environmental values
Minimize impacts to threatened and endangered species

2.2.1 RIDERSHIP AND MARKET PROJECTIONS

The Applicant has prepared a preliminary yet comprehensive ridership study⁷ which was independently reviewed by qualified specialists under the exclusive direction of the FRA.⁸

The Applicant's ridership study incorporated a comprehensive travel demand model that divided the Southern California area into zones (by postal zip codes), computed travel times and costs from those zones for the automobile and air travel modes, and then compared those modes to the time and cost of DesertXpress. The study also utilized an internet-based stated preference survey of selected Southern California residents (carried out in July 2005) to estimate how many existing auto and air trips to Las Vegas could potentially be diverted to DesertXpress.⁹

The Applicant's study forecast ridership for the year 2012, assuming application of the diesel (DEMU) technology, was based upon a 116 minute one-way travel time, and a fare of \$55 per person each way. The actual travel time would vary between approximately 90 minutes and 116 minutes depending upon the combination of alignment alternatives selected and whether the DEMU or EMU technology is used. The study found that the DEMU alternative would potentially capture 22.8 percent of the total 18.2 million annual trips between southern California and Las Vegas by 2012 (the first full start up year following a three year ramp-up period). This would represent a mode shift of 20.3 percent (or 3.4 million trips), from autos that would otherwise use I-15. On Fridays, when travel is at a peak, the Applicant's study concluded that DesertXpress would capture an estimated 17,630 total daily trips in 2012, and 19,520 on Sundays. At the baseline assumed average

⁷ Desert Xpress Updated Ridership and Revenue Study, URS Corporation, December 2005.

⁸ DesertXpress Ridership Forecast Review, Cambridge Systematics, January 2008.

⁹ Three station locations in the Las Vegas area were tested, consistent with the four station options under consideration in this EIS (see discussion in Section 2.4.9 below). Two of these locations were near the Las Vegas Strip—a Southern option (west of the I-15 along Polaris Road, across I-15 from the Mandalay Bay Resort and Casino) and a Central strip option at West Flamingo Road adjacent to the Rio Suite Hotel and Casino. The third station evaluated was located near downtown Las Vegas adjacent to a proposed monorail station for the Downtown extension. The Southern and Central stations were tested with and without the assumption of a monorail spur constructed between the DesertXpress station and a monorail station. To maintain a fair comparison between DesertXpress and air travel, extended monorail service to the airport was also assumed in the study. As a variation, both Strip area stations were tested assuming a dedicated shuttle bus for connecting service to the DesertXpress station rather than a direct monorail connection.

The probability of a trip maker switching to high-speed rail was derived from how these respondents answered questions concerning the attractiveness of high-speed rail service. The model was developed using current information (2004) to describe variables such as security delays at airports, air travel to Las Vegas, and travel costs. In addition, a survey was taken of I-15 vehicles to establish the number of California residents coming to Las Vegas by auto. Future trip levels were based on expected Las Vegas visitation in 2012, and the growth of Southern California population. The baseline forecast assumes a \$55 one-way fare in 2012, but the actual fare structure has not yet been adopted. Variations in travel time, fare level, and frequency of service can be utilized to ensure the results are equally applicable to both DEMU and EMU technology options.

fare of \$55 per one-way trip, the Applicant's study estimated year 2012 ridership for the DEMU option would be over 4.1 million round trips. In a supplement to the Applicant's study, it was noted that the EMU option, with a shorter travel time (100 minutes, compared to 116 minutes for the DEMU) and lower fare (\$50) would attract a year 2012 ridership of 5.1 million passengers. This would represent a mode shift of approximately 25 percent from automobiles that would otherwise use I-15.¹⁰

The ridership review conducted for FRA examined and evaluated the methodologies employed in the Applicant's ridership study. The ridership review noted that numerous factors could alter the findings of the ridership study in both positive and negative directions. Following consideration of all of these factors and their relative potential to alter the findings, FRA's ridership review concluded that the ridership forecast numbers prepared by the Applicant should be adjusted downwards by a factor of about 10 percent overall to represent a conservative estimate of potential ridership for the environmental analysis. The ridership review further stipulated that these downward adjustments should be applied to the forecasts of projected diversions from automobile trips originating from selected zones in Southern California. The Applicant's ridership study and FRA's ridership review are included as Appendix B.

The ridership projections with adjustments based on FRA's review were used as the basis for analysis in several sections of Chapter 3.0 of this EIS, including Section 3.2, Growth, 3.5, Traffic and Transportation, 3.11, Air Quality and Global Climate Change, 3.12, Noise and Vibration, 3.13, Energy, and 3.16, Cumulative Impacts. The ridership projections utilized in this EIS analysis are also shown in Table 2-3 below. The FRA's ridership review also included a recommended three-year ramp-up period, reaching the full projected forecast level of 10 percent less than the Applicant's forecast in 2015.

¹⁰ Sensitivity studies were completed using the 2012 trip tables. Fare level is a particularly strong variable in the automobile model, where the elasticity of demand with respect to fare is greater than 1, ranging from -1.2 to -2.1 (which suggests that any given change in the fare would result in a greater change in ridership). Fare also is important, but not quite so strong, for the air travel model, with elasticities starting at -0.8 and ranging to -1.3 at the highest level. Detailed studies completed for this project showed that the automobile mode represents 89 percent of the total Southern California travel market; therefore, auto mode will always dominate overall ridership results. Because of this high elasticity, ridership decreases rapidly as fare increases. For example, at a \$40 fare, ridership is 6.2 million annual round trips, while with a \$70 fare, ridership drops to about 2.6 million per year.

Table 2-3 Ridership Projections Utilized in EIS Analyses

	Diesel-Electric Multiple Unit (DEMU) Ridership Estimate	Electric Multiple Unit (EMU) Ridership Estimate
Opening Year 2012		
Friday	8,334	10,574
Average Daily	5,335	6,773
Annually	1,947,478	2,472,305
Year 2015 (following ramp-up)		
Friday	15,624	19,824
Average Daily	10,003	13,020
Annually	3,651,080	4,635,012
Buildout Year 2027		
Friday Riders	21,925	27,818
Average Daily	14,037	17,820
Annual Riders	5,123,418	6,504,131

Source: Cambridge Systematics, 2008; URS, 2005.

2.3 ALTERNATIVES CONSIDERED BUT DISMISSED FROM FURTHER ANALYSIS

Two existing transportation corridors exist between Victorville and Las Vegas: the I-15 freeway and the UPRR railroad. An alternative alignment was investigated that would follow the existing mainline UPRR alignment across the Mojave National Preserve (Preserve), through Cima and Kelso. While a UPRR alternative would enable the trains to avoid the steep grades along I-15, it would be a much longer, less direct route that would require the construction of new tracks through the Preserve alongside the UPRR tracks. Based on preliminary discussions with staff of the Preserve, the Applicant determined that this alignment would be less viable from an environmental impact perspective than following the median and/or north side of the I-15 alignment, which minimizes, to the greatest extent, any potential impacts to the Preserve. The Applicant also found this alternative would be significantly longer, with many speed-restricting curves which would add substantial travel time and thus fail to attract sufficient ridership.

Similarly, it was considered that any alignment alternative within the urbanized portions of the Las Vegas Valley that would not follow existing major transportation corridors (i.e., existing freeways and railroad rights-of-way) would have the potential to result in substantial adverse impacts to urban/suburban areas (such as displacement of residents and businesses, increased noise and visual impacts, and impacts to property access). Such impacts would result largely from the incompatibility of high-speed train operations within existing residential and/or commercial developments. This resulted in the elimination of routes that would divert from major transportation corridors and instead follow existing streets and boulevards.

Several other alternatives were eliminated for particular sections of the route. These are listed in Table 2-4, along with the rationale for their elimination. A subsequent key is provided to read Table 2-4.

Table 2-4 Reasons for Elimination of Potential Alignment Segments

Segment/Description	Length (Miles)	Reasons for Elimination						Concerns
		C	I	ROW	C/A	R/R	E	
1-A Victorville to Lenwood (south of Barstow, California). This alignment would have been constructed west of the Mojave River, following the existing BNSF railroad corridor and Route 66 to a point just south of Barstow.	22						P	The alignment would directly convert 8 acres Prime Farmland/Farmland of Statewide Importance and would indirectly affect more than 600 acres of such farmland. This alignment would also impact biological resources, riparian habitat, and archeological resources along the Mojave River. The alignment would also traverse a section of the Mojave Fishhook Cactus ACEC. In addition, the alignment would travel in close proximity to the Route 66-Mojave River Corridor Historic District, and would result in the demolition or major alteration of approximately 20 historic architectural resources, including portions of Route 66. The communities of Oro Grande and Helendale would also be affected in terms of environmental justice impacts.
1-J Victorville Station to Barstow via BNSF ROW. Rejected placing the intermodal terminal station located west of the Mojave River in vicinity.	29.6				P		S	This alternative location is too far from I-15 – reduces visibility and accessibility, hence negatively impacts ridership and financial viability. Adjacent uses are industrial. Would require new access road from I-15 with new road bridge over Mojave River with impacts to wetlands, habitat, biological resources, and floodplains. Would also involve grade separation of the highway crossings and relocation of a section of BNSF tracks.

Segment/Description	Length (Miles)	Reasons for Elimination						Concerns
		C	I	ROW	C/A	R/R	E	
2-J Alignment alternative eliminated from further consideration would traverse private, generally open land through Barstow and Yermo. Portions of route would pass through BNSF Barstow Yard and through residential neighborhoods.	24.6		P	S			P	Alignment is incompatible with future BNSF yard expansion; would cause noise and visual impacts to residential properties.
3-JA Yermo to Mountain Pass in I-15 Freeway corridor. This alignment would have been constructed along the south side of the I-15 Freeway ROW	84.2			S			P	An alignment south of the I-15 ROW would encroach into the Mojave National Preserve presenting permit constraints in this environmentally sensitive area; also, additional ROW (outside of existing I-15 ROW) would be required.
4-JA Mountain Pass to Primm via I-15 in the freeway median.	13.5	P		S			P	The grades on I-15 in a 4-mile section approach 6 percent. The maximum allowable grade for the project is 4.5 percent, and this alignment would require a tunnel or very deep excavation with high retaining walls over a significant length to allow construction within the existing I-15 ROW. Because the grade is too steep for train operation, this alignment alternative was eliminated from further consideration. Potential adverse environmental impacts of this alternative and constructability constraints within the I-15 median also eliminated this alternative from further consideration.

Segment/Description	Length (Miles)	Reasons for Elimination						Concerns
		C	I	ROW	C/A	R/R	E	
3/4-J Roughly parallels Segments 3 and 4, but alignment would be solely in UPRR ROW or adjacent property.	120			S		P	P	This alignment alternative would be approximately 23 miles longer than the I-15 corridor and would add running time to the project. Longer, slower route would reduce ridership, revenue, and financial viability. This alignment alternative would also involve relocation of existing UPRR tracks and major grading. With greater length and relocation of rail facilities and passing through the Mojave National Preserve, this alternative would have environmental noise, visual and biological impacts to the Preserve and would impact UPRR operations during construction.
5-JA Primm to Las Vegas via I-15 Freeway. Generally, deviating from the I-15 ROW and passing through areas with existing and planned residential or commercial development.	39.5		S	P			P	An alignment that would not follow existing transportation corridors would result in a need to acquire properties with existing residential or commercial development, which would be very costly and have noise and visual impacts incompatible with adjacent land uses.
5-JB Primm to Las Vegas via UPRR corridor where the alignment would deviate from the UPRR ROW and pass through existing residential development areas.	40.1		S	P			P	Acquiring properties that comprise existing residential or commercial development would be very costly and would be incompatible with adjacent land uses from noise and visual disruption of passing trains.

Source: DesertXpress; CirclePoint, 2008.

Definitions: Reason for Elimination: (P) Primary and (S) Secondary

C=Construction: Engineering and construction complexity; initial and/or recurring costs that would render the project impractical; logical constraints.

I=Incompatibility: Conflicts with land use designations or has insurmountable long term impact to highway or railroad operation.

ROW=Right-of-way: Significant land cost.

C/A=Connectivity / Accessibility: Inhibits or precludes convenient transfer to other modes or access to terminal station facilities.

R/R=Revenue / Ridership: Severe long term operation or maintenance cost; significant increase in running time over a more direct alignment.

E=Environment: High potential for significant impacts to natural resources, including streams and wetlands and habitat of threatened or endangered species.

2.3.1 TRAIN TECHNOLOGIES CONSIDERED BUT REJECTED

The Applicant considered various train technologies for the DesertXpress project, and sought to particularly identify a train with proven reliability that could be readily adapted to the unique desert environment of the Mojave/Las Vegas region and deliver reliable and rapid performance on the long and relatively steep grades along portions of the route. The Applicant found that steel-wheel train systems with distributed propulsion (with most of the passenger cars on the train being powered) the only viable technology and rejected other train technologies including magnetic levitation so as to allow for potential future system expansion without concerns regarding potentially proprietary technology, while ensuring the project's economic viability. The Applicant also found magnetic levitation technology to be cost-prohibitive within a privately-funded project. (An objective for the Applicant was to develop a mobility alternative for the I-15 corridor without the use of any public funding).

A conventional locomotive-hauled train with non-motorized passenger cars was initially studied by the Applicant, but eliminated after train simulation models showed unsatisfactory results in performance and predicted reliability on the route's long, steep grades.

Discussion of the DEMU and EMU technologies that remain under consideration in this EIS can be found in Section 2.4.9 below.

2.4 ACTION ALTERNATIVES IN DETAIL

The project corridor between Victorville and Las Vegas has been divided into seven segments for analysis purposes. Segments contain alternative alignments as summarized below.

2.4.1 SEGMENT 1, VICTORVILLE TO LENWOOD (APPLICANT'S PROPOSED ALTERNATIVE)

Segment 1 would depart from either of the two possible Victorville Station sites and head north generally following the west side of the I-15 corridor for a distance of 25 to 29 miles, depending on whether the alignment starts at Victorville station site 1 or 2. Only one alignment is being evaluated in this EIS for Segment 1. The alignment would diverge from the I-15 corridor near Hodge Road and head northerly to a point just south of Barstow near (but not within) the existing BNSF railroad corridor.

Segment 1 would include a new bridge over or under the Mojave Northern Railroad and a second bridge over the BNSF mainline tracks, as well as eight roadway overpasses (to provide a fully grade-separated alignment). Segment 1 would have a maximum grade of about 2.5 percent. Figure 2-3 shows a typical section alongside I-15 where the DesertXpress tracks would fit within the existing I-15 right of way without requiring modification or reconstruction of the existing I-15 freeway. This typical cross section

would also allow for potential future widening of the I-15 freeway. Figure 2-4 shows a typical section of the DesertXpress tracks situated on a retained embankment alongside I-15. Figure 2-5 shows a typical aerial structure design where the new tracks would need to be grade separated. Segment 1 would use the grade separated tracks where the alignment would cross the existing I-15 interchanges.

2.4.2 SEGMENT 2

2.4.2.1 Segment 2A/ 2B, Lenwood to Yermo via Barstow Routings

From Lenwood to east of Barstow, Segments 2A and 2B would share the same alignment for 12 miles, then diverge for the next 9 miles. Throughout the EIS, this portion of the alignment is referred to as Segment 2A/2B and the alternatives are combined for analysis. The remaining portion of Segment 2 where Alternative A and B alignments diverge is then referred to as Segment 2A and Segment 2B. Refer to Appendix A for the large-scale maps showing the detailed location of Segments 2A and 2B. Figure 2-1.2 also shows the location of Segments 2A and 2B. The first five miles of the combined alignment for Segment 2A/2B would be on newly created tracks for exclusive high-speed rail use and would cross the Mojave River and turn east through the City of Barstow. Through the City of Barstow, the alignment would utilize a former Atchison Topeka & Santa Fe (AT&SF) railroad corridor along the north side of the Mojave River, for approximately three miles before reaching the vicinity of the I-15/Old Highway 58 interchange on the east side of Barstow.¹¹

The combined Segment 2A/2B would require a bridge over the Mojave River, a bridge (or underpass) for roadways in the I-15/Old Highway 58 interchange area, and a bridge (or underpass) over or under the westbound lanes of I-15 near the agricultural inspection station, as well as seven grade-separated roadway overpasses. In this section, the design concept requires about 50 feet of width for the DEMU alternative and 60 feet for the EMU alternative and the cross streets in this segment would need to be grade separated using overpasses. Figure 2-3 and Figure 2-4 represent typical sections of the at-grade and retained embankment DesertXpress tracks. While I-15 is shown in these figures, the typical track cross-sections also apply to portions of Segment 2A and 2B that would be created on the new right-of-way for high-speed rail outside of the I-15 right-of-way. Figure 2-5 presents the typical design for the grade separated tracks used in Segments 2A and 2B as well.

¹¹ This portion of the former AT&SF right of way fell out of use when the railroad constructed a new line at the west end of their yard near Highway 58. Tracks were removed from this area at an unknown date. Because the tracks in question fell out of use due to a realignment, no petition for formal abandonment was required to be filed with or approved by the Surface Transportation Board. Personal communication, Don Bratton (Staubach Company; acting property managers for BNSF Railroad, 1/19/07; Christine Glaab, Surface Transportation Board librarian 1/4/07.

2.4.2.2 Segment 2A (Applicant's Proposed Alternative)

Upon emerging from the combined portion (Segment 2A/2B) near the I-15/Old Highway 58 interchange on the east side of Barstow, Segment 2A would follow a more northerly course outside of the I-15 freeway corridor for 9.3 miles.

2.4.2.3 Segment 2B

Upon diverging from Segment 2A after the I-15/Old Highway 58 interchange on the east side of Barstow, would run along the north side of the I-15 corridor past the community of Yermo, to a point just east of the agricultural inspection station on I-15. Segment 2B is approximately 9.2 miles.

2.4.3 SEGMENT 3

2.4.3.1 Segment 3A, Yermo to Mountain Pass via Freeway Median

Segment 3A would be located entirely within the median of the I-15 freeway, running 84.9 miles. Generally, the existing median is approximately 100 feet wide (between edge of traveled way to edge of traveled way). The exception is in the community of Baker, where the median narrows considerably, where the I-15 freeway would need to be widened to the outside to provide room for the rail in the median, or alternatively, the alignment would need to diverge from the median or be placed on an aerial structure. The Plan and Profile Drawings in Appendix A show Alternative A diverging from the I-15 freeway median west of Baker and re-entering the freeway median east of East Baker Boulevard.

It is assumed that a continuous concrete vehicle barrier would be required on both sides of the tracks, as well as American Railway Engineering Maintenance of Way Association (AREMA) crash barriers at all supporting columns of bridges at freeway interchanges and overpasses. Bridges for tracks would also have to be constructed where significant waterways cross I-15. Drainage for the trackway would be designed to integrate with the existing I-15 drainage system.

Figure 2-6 shows the proposed typical cross-section in the median of I-15, which includes full median shoulders, barriers, the two DesertXpress tracks, and a parallel inspection and maintenance access road. This cross-section would also allow future widening of the I-15 freeway. Grade-separated crossovers for California Highway Patrol and other authorized vehicles would be provided. Figure 2-7 shows the design concept of the grade separated DesertXpress tracks that would be used within the I-15 median at interchanges and overpasses to avoid conflicts with the existing overpass columns. A typical section of the design of the retained embankment of the DesertXpress tracks within the I-15 median is also shown in Figure 2-8. Figure 2-9 shows the typical median drainage treatment where the drainage from the median is tied into the existing I-15 drainage system.

2.4.3.2 Segment 3B, Yermo to Mountain Pass via Freeway Right-of-Way (Applicant's Proposed Alternative)

Segment 3B would be located along the north side of I-15 within the existing freeway right-of-way from Fort Irwin Road to Mountain Pass, running 84.8 miles. Figure 2-3 and Figure 2-4 show the typical design concept alongside I-15, which for the most part enables the DesertXpress tracks, drainage, parallel access road, and separation barrier to be constructed within the existing I-15 right of way, while still leaving sufficient space for future I-15 widening. Figure 2-5 shows the typical design concept of the grade separated aerial structures for the DesertXpress tracks that would be used for crossing roadways and at the I-15 interchanges, from the on-off ramps.

2.4.4 SEGMENT 4

2.4.4.1 Segment 4A, Mountain Pass to Primm via Nipton Road (Applicant's Proposed Alternative)

Segment 4A extends for 14.0 miles. Segment 4A would leave the I-15 freeway corridor at the point that the grade exceeds 4.5 percent, just east of Mountain Pass. Segment 4A would head south for approximately four miles before returning to the I-15 freeway corridor south of Primm. An approximately 1.55 mile portion of this alignment may encroach on the Mojave National Preserve near the intersection of Nipton Road and Ivanpah Road, all within about 0.5 miles of I-15. While portions of Segment 4A would not be adjacent to I-15 or within the I-15 right-of-way, Figure 2-3 represents a typical section of the DesertXpress tracks in this segment.

As with Segment 3, when in the median, a continuous concrete truck barrier would be required on either side of the tracks, as well as AREMA crash barriers at all supporting columns of bridges at freeway interchanges and overpasses (same as shown in Figure 2-6). Bridges for tracks would also be constructed over the northbound lanes of I-15 at each end of the dogleg into and out of the median and over Nipton Road. Also, a portion of the alignment would follow (and bridge over where necessary) a significant drainage way running parallel to I-15 from Mountain Pass.

2.4.4.2 Segment 4B, Mountain Pass to Primm via Clark Mountains

Segment 4B would leave the I-15 freeway right-of-way and head northeast, passing through two new dual track tunnels (one approximately 5,000 feet long and the other approximately 1,300 feet long), then descend along the eastern slope of the Clark Mountains on a 4.5 percent grade, before returning to the I-15 corridor south of Primm where the tracks would pass over the southbound lanes of I-15 to enter the median. The proposed tunneling activities would be administered through monitored targeted blasts and charges. Spoil material that would result from tunneling would be used for fill material for other segments of track. At Primm, the track would cross over the northbound lanes of I-15 and continue northward along the east side of the I-15 corridor. Figure 2-4 shows the typical design concept for a significant portion of this segment,

where the alignment would be on a side slope and some use of retaining walls likely would be required both above the tracks and below them. The retained embankment in Segment 4 would not, however, be located adjacent to the existing I-15 freeway, as shown in Figure 2-4. Segments 4B would extend 12.9 miles in full.

2.4.5 SEGMENT 5

2.4.5.1 Segment 5A, Primm to Jean via Freeway Median

Segment 5A would be entirely within the median of I-15, running 24.6 miles. The design concept is similar to the median alternative in Segment 3 (see Figure 2-6). In sections where the median would be too narrow to achieve the required median cross section, the I-15 shoulders would be extended on both sides to create the required median width in accordance with NDOT and Federal Highway Administration geometric design requirements or the train would be placed on an aerial structure.

2.4.5.2 Segment 5B, Primm to Jean via Freeway Right-of-Way (Applicant's Proposed Alternative)

Segment 5B would continue along the east side of the I-15 corridor between Primm and Jean within the existing freeway right-of-way for 24.6 miles. The design concept for this segment is essentially similar to that shown in Figure 2-3, except that the train would be on the east instead of west side of I-15.

2.4.6 SEGMENT 6

Within Segment 6, where the area traversed by the alignment becomes more urbanized and there is insufficient width available to implement the design treatments used in Segments 1-5, the tracks would be placed on new elevated structures. This applies to both alignment alternatives, Segments 6A and Segment 6B. Specific locations within the alignments where elevated structures would be used can be seen in the plan and profile drawings included in Appendix A.

If the Downtown station option is selected, Segment 6 would bypass the Southern station and terminate just north of Tropicana Avenue. See the discussion of Segment 7 below.

2.4.6.1 Segment 6A, Jean to Southern or Central Passenger Stations via Freeway Median

Segment 6A would continue in the median of I-15 into the Southern, Central "A" or Central "B" passenger stations, a distance of about 14 miles.

After entering the urbanized area, a significant portion of this alternative would be located on an aerial structure, due to the large number of major interchanges and overpasses that would need to be traversed, as well as the proximity of urbanized development to the existing freeway right of way. Where the tracks are feasible in the median, a continuous

concrete vehicle barrier would be provided on either side of the tracks, as well as AREMA crash barriers at all supporting columns of bridges at freeway interchanges. Figure 2-5 shows the typical elevated design concept that would be applied in the median within the urbanized areas of this segment.

2.4.6.2 Segment 6B, Jean to Southern or Central Passenger Stations via Freeway Right-of-Way (Applicant's Proposed Alternative)

Segment 6B would cross the I-15 corridor from the east side to the west side and continue along the west side of the I-15 corridor into the Southern, Central "A" or Central "B" passenger stations, a distance of about 14 miles. Bridges for tracks would be constructed over the northbound lanes of I-15 just north of Primm and over the UPRR. As with Segment 6A, it is assumed that significant sections of this alignment could require placing the tracks on elevated structures to provide sufficient space for railroad operations and account for the proximity of adjacent urban development. Figure 2-5 shows the typical elevated design concept that would be applied on the side of the freeway within the urbanized areas of this segment.

2.4.6.3 Segment 6C, Jean to Central A/B Passenger Stations via UPRR Corridor

Option C would diverge from Segment 6A/6B near the community of Sloan and generally follow the existing UPRR corridor (primarily within the UPRR right-of-way) into either of the Central passenger station options, a distance of about 16 miles, depending on the terminus. Option C would not connect to the Southern station.

In some sections of this segment, there appears to be sufficient width for the two new DesertXpress tracks to be constructed alongside the UPRR tracks, but with elevated or underground grade separations over or under all UPRR spur tracks. DesertXpress tracks would be a minimum of 50 feet from the UPRR tracks, as Cal-Nevada has a high pressure gasoline pipeline in the UPRR right-of-way. In some sections of Option C, it would be necessary for the DesertXpress tracks to be placed on a new aerial structure. Figure 2-5 represents the typical aerial structures used for the grade separated DesertXpress tracks in this segment.

2.4.7 SEGMENT 7

The Segment 6 Action Alternatives would terminate at either the Southern, Central "A" or Central "B" station options (excepting Option C, which could not terminate at the Southern station option). If, and only if, the Downtown Las Vegas station is selected as the terminus, the Segment 7 alignment options would be utilized. If the Segment 7 alignment option is utilized, Segment 6 would bypass the Southern station option and terminate at West Twain Avenue. Segment 7 would then originate at West Twain Avenue and continue into the proposed Downtown Las Vegas passenger station.

2.4.7.1 Segment 7A, West Twain Avenue to Downtown Station via Freeway Median

From West Twain Avenue, Alternative A would continue the pattern from Segment 6, with the alignment in the I-15 median. Segment 7A would bypass the Central A and Central B station sites, and continue in the I-15 median toward the Downtown Las Vegas passenger station, crossing under existing I-15 overpasses en route, a total distance of about 4.9 miles. Portions of Segment 7A could be placed on aerial structures due to limited width of the I-15 median in this urbanized corridor. Figure 2-7 shows the typical elevated design concept within the median for this segment.

2.4.7.2 Segment 7B, West Twain Avenue to Downtown Station via Freeway Right-of-Way (Applicant's Proposed Alternative)

From West Twain Avenue, Action Alternative B would continue the pattern from Segment 6, with the alignment in the I-15 corridor. Segment 7B would bypass the Central A and Central B station sites, and would continue in the I-15 corridor toward the Downtown Las Vegas passenger station, crossing under existing I-15 overpasses en route, a total of about 5.0 miles. Portions of Segment 7B would be placed on aerial structures due to limited width of the I-15 median in this urbanized corridor. Figure 2-5 represents the typical aerial structures used for the grade separated DesertXpress tracks in this segment.

2.4.7.3 Segment 7C, West Twain Avenue to Downtown Station via UPRR Corridor

Option C would be utilized in Segment 7 only if it were elected in preceding Segment 6. Option C would begin at West Twain Avenue within the UPRR corridor and would continue within the UPRR corridor to the Downtown Las Vegas station. Portion of this option would be placed on aerial structures due to the urbanized nature of this corridor; the typical aerial structures used for the grade separated DesertXpress tracks are illustrated in Figure 2.5. Segment 7C would be about 4.5 miles in length.

2.4.8 HIGH-SPEED TRAIN TECHNOLOGY OPTIONS

The Applicant has selected existing European intercity high-speed trains, customized for the unique setting of the corridor. Both diesel/electric multiple unit (DEMU) and electric multiple unit (EMU) train sets are being considered as high-speed train technology options. The Applicant has identified two Bombardier train sets, the Meridian and Regina, as representative examples of the respective DEMU and EMU technology options. Meridian DEMU trains are currently operating in the United Kingdom; various derivations of the Regina EMU trains are currently operating in Sweden and China. The DEMU train set is projected to operate at a maximum speed of 125 mph. The EMU train set could have a maximum speed of 125 mph or 150 mph.

Detailed train simulations studies for the Applicant's Preferred Action Alternative Alignment have been run for 10-car trains. This length was based on the peak travel

demand forecast. Simulation results showed that seven to eight of the train cars would be powered, although all train cars could be self-propelled. This configuration provides the high power-to-weight ratio and distributed traction needed to follow the I-15 corridor and negotiate the steep grades through the two desert mountain passes (the Applicant's design criteria limits slopes to a 4.5 percent maximum grade).

However, the EMU trains are wider and longer than the DEMU trains, which enable each EMU train to carry approximately 41 percent more passengers than a DEMU train. As previously noted, the EMU option would require the addition of 17 autotransformers and three electrical substations along the route. The autotransformers would be located at approximately 10-mile intervals along the rail alignment. Locations for these autotransformers are shown in Figures 2-1.1 through 2-1.7. Appendix A also provides detailed locations of the autotransformers, as seen in the Plan and Profile drawings and the large-scale maps. The three electrical substations would be located on the sites of the Victorville OMSF, Baker MOW, and Sloan MSF facilities. The substation diagrams and layouts are as shown on the detailed site plan drawings for the referenced maintenance facilities within Appendix A. EMU and DEMU train lengths, platform width requirements, and other differing features of the train sets are identified in Table 2-6 below.

Table 2-6 Summary of Key Operating Features, DEMU and EMU

	DEMU (Meridian)	EMU (Regina)
Train Length	232 meters (±761.2 feet)	267 meters (±876.0 feet)
Platform Length Required	250 meters (±820.2 feet)	280 meters (±918.6 feet)
Passenger Capacity Per Ten-Car Train	478	675
Top Speed	125 miles per hour	125-150 miles per hour
Average Speed	100 mph	112 mph or greater
Approximate One-Way Travel Time Between Victorville and Las Vegas	116 minutes	100 minutes at 125 mph top speed; 84 minutes at 150 mph top speed

Source: DesertXpress

As a standard gauge steel-wheel on steel-rail system, DesertXpress would be readily expandable and could accommodate other models of standard-gauge passenger trains.

Trains would be operated under manual control and would be equipped with cab signaling that enables the train operator to receive speed commands for each section of the route, with an automatic train protection system that includes over-speed detection and automatic braking in the event a train operator were to exceed the allowable speed command. A central Operations Control Center (OCC), located within the Victorville OMSF, would control the routing of trains, cab signals and track switches. Each train would be equipped with state-of-the-art safety features, including backup emergency communications in the event of a primary loss of power. However, by selecting a distributed power system rather than a locomotive-hauled train, the train technology

would be inherently very reliable, such that loss of propulsion within any car would not materially affect the safe and reliable performance of the entire train.

2.4.9 PROJECT COMPONENTS COMMON TO ALL ACTION ALTERNATIVES

2.4.9.1 Project Operation Components

Operating Plan

Detailed train performance simulations have been completed to estimate travel time. The travel time results were incorporated into a preliminary operations plan, which was reviewed by FRA as part of this EIS. Appendix C contains the FRA review of the operations plan.

The operations plan examined both technologies under consideration, the Electric Multiple Unit (EMU) or Regina trainset and the Diesel-Electric Multiple Unit (DEMU) or Meridian trainset.

The plan estimates that the peak operational fleet required to meet the peak daily demand would be range from 12 (EMU) to 16 (DEMU) trains of 10 cars each, plus spares, in the first full year of operation (2012).

The entire mainline section between Victorville and Las Vegas would incorporate dual tracks, one northbound and one southbound, to support the high ridership and frequency of train operation. The “normal,” or nominal, direction of travel would follow the North-American practice of right-hand running. All tracks would be signaled for bi-directional operation should operating in reverse on a track be necessary.

The preliminary Operations Plan assumes that trains would operate between approximately 0600 hours and 2200 hours (6 a.m. to 10 p.m.), 365 days per year. The hours of service could be extended if passenger demand should warrant additional operation.

The initial train composition is a ten vehicle train. Passenger capacities for DEMU trains would be about 478; for EMU trains, which have slightly longer and wider cars, capacity would be about 675 passengers. On either train, one of the ten cars would be configured as an entertainment car.

Supervision of train movements, station operation, and wayside equipment would be provided by authorized personnel in the OCC located at the Victorville facility in the administration building. The OCC staff would be responsible for all functions and procedures performed on the main line. Accordingly, the OCC staff would have the capability to monitor and govern various aspects of the system through dynamic displays, status reports, voice and visual communication, and through commands/instructions via their computer interfaces.

At the maintenance facility and layover yards, speed commands and OCC supervision would extend into the entry point of the yard. From the entry of the yard to the storage tracks, the trains would be operated manually (15 mph maximum). The switches in yards would still be interlocked and controlled by the OCC. Switches at the direct leads to the maintenance building would not be under the supervision of the OCC and would be manually operated as trains are moved in and out of the maintenance building.

Bombardier, as well as the project Applicant's independent technology consultants, Interfleet Technologies Ltd. from the UK, has performed a preliminary analysis and simulation of the DesertXpress High-speed Rail System using the following maximum parameters applicable to the EMU operating system:

- maximum cruise speed of 125 mph (and, for the EMU option only, alternate top speed of 150 mph)
- maximum acceleration rate of 1.8 mph/s (0.75 meters/second)
- maximum deceleration rate of 2.5 mph/s; and
- maximum actual super elevation of 6.0 inches.

Depending upon the direction of travel and the specific alignment and station locations, one-way travel times are in the range of 84 to 100 minutes for the EMU technology option, to 116 minutes for the DEMU technology option. DEMU average speeds would be approximately 100 mph while EMU average speeds would be approximately 112 mph with a 125 mph top speed. At a top speed of 150 mph the average speed would be approximately 130 mph. Shorter alignments would enable a shorter travel time.

To meet the projected ridership, trains would depart from both ends of the line on 20 to 30 minute frequencies during peak weekend hours and up to approximately once per hour during the week.

FRA's review of the operations plan (Appendix C) found that the operating proposals set forth by DesertXpress were reasonable and set forth suggestions for the project Applicant to consider as operating plans continue to evolve.

Safety and Security

All alignment routings would include several cross-track switches at prescribed intervals to enable continuity of high-speed train service in the event of a track blockage.

Equipment redundancy, high reliability, daily service and inspection in conjunction with preventive maintenance schedules, failure monitoring of vehicle and wayside equipment, and corrective responses would ensure a high level of DesertXpress service availability. In the event of minor failures, trains would continue to operate with little or no impact on service. In addition, a failure and emergency response system would be in place to govern response to partial or full system stoppages requiring immediate intervention by authorized personnel. Response personnel would be on call 24 hours a day to quickly address such failures and emergencies. The DesertXpress failure management system

would also rely on a variety of strategies to minimize the downtime and passenger inconvenience caused by vehicle and wayside failures. These would include:

- Automatic responses at the subsystem and/or the system level;
- Local (manual) reset of equipment;
- Remote reset of equipment by the Operations Control Center;
- Recovery/removal of a failed train with a revenue train or a recovery train;
- Replacement of failed train with hot standby train
- Alternate routing using shuttles and bypass routes, and
- Appropriate inspection checks on tracks before service is restored.

If service must be suspended around a problem site for any extended period, the Operations Control Center would implement a shuttle, bypass or short turnback strategy to provide reduced service for the remainder of the System.

Peak demand is met by providing the train length (number of cars per train) and frequency of service required to meet the projected demand. The preliminary ridership and revenue forecasts indicate that 10-car trains would be sufficient to carry the demand for the foreseeable future. Thus, the Applicant's Operating plan shows that each train would consist of ten cars with service operating at 20-minute frequencies during the highest demand periods. As ridership demand increases over time, peak period ticket pricing strategies would be used, such that 20-minute service frequency is anticipated by the Applicant to be sufficient for many years. If necessary at some point to meet additional demand, longer trains could be used, or additional 10-car trains would be put in service to provide higher capacity through more frequent scheduling.

Any fault occurring on any vehicle unit would be regarded as a train fault. There are numerous types of faults that possibly could occur with varying degrees of (potential) impact to system availability or threat to passenger safety. For this reason, onboard faults are characterized by the responses they would invoke, both by the OCC and by the train crew. Responses to train faults would range from the fault being noted and fixed at the next scheduled maintenance period to the emergency braking of the train. In the event of a train obstructing the alignment for extended periods, a degraded service mode would be implemented and the hot standby train, a recovery train, or the nearest in-service train, would be sent to clear the track. In the event of an emergency requiring immediate train evacuation, which would only occur very infrequently, train passengers would be evacuated to the 10 foot wide minimum maintenance road area that would run adjacent to the trackway or other suitable location, following review and approval of the System Safety Plan by the appropriate emergency services organizations.

The DesertXpress tracks in either the DEMU or EMU technology option would be fenced. To protect against guideway or right-of-way entry by unauthorized persons or objects, chain link fencing, at a minimum of 6 feet in height, would be provided between any barrier structure and the train tracks, at a distance of approximately 30 inches from the centerline of the barrier. In some segments, fencing may also be mounted on top of the barrier, with a combined minimum height of 6 feet. Fencing would not be required where

any barrier or retaining wall would exceed 6 feet in height. Transformers placed at regular intervals along the route would be located within the median of the fenced alignment, preventing unauthorized access. If the EMU technology option is selected, additional safety features would be integrated into the project. For example, fencing would be provided to restrict access to electrical equipment. The three substations required in the EMU technology option would be separately fenced and secured.

All fenced areas of the DesertXpress right-of-way that could be accessed on foot would incorporate an intrusion detection system. The intrusion detection system would include continuity wire loops that are capable of detecting large objects that may strike or rupture the chain link fence. The intrusion detection system would be tied into the train control system to allow either warning of train stop, as detailed in the Safety and Security Plan and Hazards Analysis being prepared by the Applicant. The Safety and Security Plan and detailed Hazards Analysis would be incorporated into the DesertXpress standard operating procedures.

Intrusion detection systems would also be provided as part of the DesertXpress project as required by the FRA. To protect the DesertXpress tracks against intrusion by unguided automotive vehicles, including motorcycles, automobiles, and trucks, barriers would be placed near the edge of the highway shoulder lanes. For the at grade DesertXpress tracks adjacent to or within the median of the I-15 freeway, permanent concrete barriers would be installed between the tracks and the roadway, per Caltrans' and Nevada Department of Transportation (NDOT) requirements. Where the DesertXpress tracks are located on an elevated structure more than 6 feet above grade, no barrier would be required.

Overhead highway structures adjacent to or crossing the DesertXpress right-of-way would be protected by crash walls surrounding the base piers. The crash walls would be specifically designed to withstand the impact of a derailed train and to deflect a derailed train away from the supporting structure. At a minimum, these crash walls would be installed per the requirements of American Railway Engineering and Maintenance-of-Way Associated (AREMA) Manual for Railway Engineering. Curved overhead highway structures would also include highway barriers in compliance with Caltrans and Nevada DOT standards. Additionally, any overpass crossing the DesertXpress tracks would require a minimum clearance of approximately 16 feet, 9 inches. Chain link fencing on the roadway overpasses would also be constructed to protect objects from falling onto the DesertXpress trackway.

2.4.9.2 Alignment Features

Where the DesertXpress alignment would be within the I-15 corridor, continuous concrete vehicle barriers, as well as AREMA crash barriers at all supporting columns of bridges at freeway interchanges and overpasses would be provided. Tracks would be spaced 15 feet apart. The I-15 median alternative would include drainage bunds, channels, and utilities. Final design for all segments of the project in the median or immediate proximity to I-15 would be reviewed and approved by Caltrans, NDOT, and FHWA.

The system would use #20 high-speed switches to facilitate recovery and bypass strategies. The #20 switch utilizes two machines for switch point movement and permits a maximum tangent speed of 125 mph and a maximum turnout speed of 50 mph. Switches for the sidings would be #10.

As a fully grade-separated passenger railway, structures and bridges would be constructed at major crossings of roads, rail tracks,¹² and waterways or floodways, including the Mojave River crossing at Lenwood Road, Oro Grande along Route 66, Fort Irwin Road in Barstow, the Highway Patrol Inspection Station on I-15, the Flamingo Wash, and other features. In addition, switch tracks may require additional crossings over I-15 or any of the noted major features. River crossings would require approval of the United States Army Corps of Engineers (404(b)1 approval).

2.4.9.3 Built Facilities

The proposed action would include the construction of one passenger station at each end of the rail corridor (Victorville plus one in Clark County or the City of Las Vegas). Stations would meet accessibility requirements of the Americans with Disabilities Act (ADA). A major maintenance, storage, and operations facility would be located in Victorville, southeast of the Victorville station site options. A secondary maintenance and storage facility would be located in Clark County. These are discussed in detail below. With the exception of Segment 7 and the associated Downtown Las Vegas Station (described below), no station or maintenance facility option would be attached to a single project alternative. Any of the proposed alignments would utilize any of the station and maintenance facility options.

Stations have been laid out by the Applicant to initially use two tracks and accommodate the addition of a third track in the future when peak operating frequencies greater than one train departing every 20 minutes may be required. The station footprints provide sufficient space for future expansion to include a third track and platform. Current travel forecasts indicate that peak period operating frequencies of 20 minutes could suffice for many years as peak pricing policies are adopted.

Victorville Station Options

Two sites north of central Victorville are being considered for the Victorville station. Both sites are located immediately west of I-15 and both stations sites would serve both Alternative A and B alignments. Segment 1 of the alignment would initiate from the selected station site. Site 1 is located just north of the southern Stoddard Wells Road exit (Exit #154); Site 2 is located to the northwest of the northern Stoddard Wells Road exit (Exit #157). The two site options are located about 1.5 miles apart. Figures 2-10 – 2-13 show site plans and section views for the two Victorville station site options.

¹² Any over or undercrossings of operational rail tracks is potentially subject to approval by the STB under 49 U.S.C. 10901(d)(1).

The facilities directly associated with the either station site would occupy about 100 acres and would have a parking capacity for approximately 13,000 to 18,000 vehicles in self-parking lots, valet parking areas, and a proposed parking structure.

The Victorville station would offer train ticketing, baggage handling, and hotel room check-in for Las Vegas resorts. The train station would be compatible with land use plans already proposed by the City of Victorville for mixed-use development served by local transit, and with highway access.

Operations, Maintenance, and Storage Facility Options

Each of the two Victorville station site options is paired with a particular site for an operations, maintenance, and storage facility (OMSF). Both OMSF site options fall within the vicinity of Segment 1 and could serve either Alternative A or Alternative B alignments. The facility would require approximately 50 acres¹³ and would include a train washing facility, repair shop, parts storage, operations control center, and a fueling station (for the DEMU option only).

OMSF site option 1, which would function with Victorville Station Site 1, would be located in the City of Victorville on a site that lies within the General Plan's North Mojave Planning Area to the southwest of proposed Victorville station site 1.

OMSF site option 2, which would function with Victorville Station Site 1 or 2, would be located north of station site 2, near the intersection with Dale Evans Parkway. A portion of OMSF site option 2 would fall within the jurisdiction of the City of Victorville; the entire site is under the jurisdiction of San Bernardino County.

Within the OMSF, the OCC would provide continuous monitoring of the train operations. Central control room personnel would have the ability to communicate directly with each train and with emergency response personnel throughout the route. Additionally, once inside the OMSF maintenance yard, the trains would be manually operated and moved with a tractor to minimize locomotive emissions within the yard. Approximately 400 employees would be based at the maintenance facility and operations center.

Figure 2-14 provides a plan view of site option 1 for the OMSF; Figure 2-15 provides a plan view for site option 2.

¹³ Site envelopes for the OMSF range in size from about 95 acres to 260 acres. Entire sites were analyzed in this EIS, although the final footprint of the OMSF is expected to be notably smaller than the areas surveyed.

Las Vegas Area Station Options

Four options are being considered for the Las Vegas passenger station:

- Southern Station, along Polaris Road, between West Russell Road and West Hacienda Drive, across I-15 from the Mandalay Bay Resort and Casino (as shown in Figures 2-16 and 2-17);
- Central Station A, between West Flamingo Road and West Twain Avenue, adjacent to the Rio Suites Hotel property (as shown in Figures 2-18 and 2-19);
- Central Station B, south of West Flamingo Road, in an area along the UPRR right of way that is currently occupied industrial/light industrial uses. (Figures 2-20 and 2-21)
- Downtown Station, in the City of Las Vegas, along South Main Street between West Bonneville Avenue and Boulder Avenue (see Figures 2-22 and 2-23).

The Southern, Central “A” or Central “B” passenger stations would be utilized with Segments 6A or 6B and serve as the terminus for those segments. Segment 6C could extend only to the Central “A” and Central “B” station sites. Segments 7A, 7B and 7C would be needed if, and only if, the Downtown station is selected as the terminus for the preferred alternative.

All potential Las Vegas station options are in close proximity to the Las Vegas Strip and related attractions which would be accessible via taxis, shuttle buses, and potential future extensions of the Las Vegas Monorail. Only one station would be utilized in the preferred alternative.

The facilities directly associated with the station site would occupy about 30 to 60 acres, depending on location. Each station would include parking for approximately 2,000 vehicles and passenger pick-up/drop off area.

Las Vegas Area Maintenance and Storage Facility

A light maintenance, storage, cleaning, and inspection facility would also be built near the northern terminus of the project. The facility would require approximately 7 to 10 acres.

Three site options are under consideration for the Las Vegas area Maintenance and Storage Facility (MSF), as shown in Figure 2-24.

Sloan Road: This site is located along Segment 5 in unincorporated Clark County, approximately 5 miles south of Sloan Road, on the east side of I-15. The site is between the I-15 freeway and South Las Vegas Boulevard (Nevada State Route 604), near where Union Pacific Railroad (UPRR) crosses from east to west side of I-15.

Wigwam Avenue and Robindale Avenue: These two sites are located in unincorporated Clark County, west of the I-15 freeway, and about one half mile south of Blue Diamond Boulevard (Nevada State Route 160).

Figures 2-25 through 2-27 depict site plan options for the Las Vegas area MSF. Detailed facility footprints and elevation drawings are included in Appendix A.

2.4.9.4 Autotransformers and Substations

If the Electrical Multiple Unit (EMU) technology option is selected, propulsion power would need to be delivered along the alignment by a series of autotransformers and electrical substations.

Three substations would be needed along the entire route, one near each end of the rail line and one near the midpoint. The substations near the ends of the rail line would be located on the corresponding O/MSF sites. The three electrical substations would be located on the sites of the Victorville OMSF, Baker MOW, and Sloan MSF facilities. The midpoint substation would be located on the site also designated for the maintenance of way facility in Baker. Substation diagrams and layouts are as shown on the detailed site plan drawings for the referenced maintenance facilities within Appendix A.

Preliminary engineering identified the need for a total of 17 autotransformers, spaced at 10 to 12 mile intervals along the alignment. These autotransformers help to maintain and regulate the voltage along the line. Each autotransformer would require a physical footprint of about one-tenth to one-fifth of an acre. Locations for these autotransformers are shown in Figures 2-1.1 through 2-1.7. Appendix A also provides detailed locations of the autotransformers, as seen in the Plan and Profile drawings and the large-scale maps.

2.4.9.5 Utility Corridors

Under the EMU technology option, utility corridors would be implemented to provide power line paths to feed the four DesertXpress substations. There are three proposed utility corridors listed below and shown on Figures 2-1.1, 2-1, 4, and 2-1.6, as well as on larger maps within Appendix A-2.

- **Victorville OMSF:** A utility corridor parallel to I-15 that would provide connection to either OMSF Site 1 and OMSF Site 2
- **Baker MOW:** A utility corridor from the Southern California Edison substation at Nickle Mountain Road following Silver Lane to Arnold Avenue to the Baker MOW Facility Site.
- **Sloan MSF:** A utility corridor from the Nevada Power Transmission Line, served by the Nevada Power Big Horn Substation located north of Primm, to the Sloan Road MSF site adjacent to I-15.

There are two potential electricity source options for the utility corridor to the Victorville OMSF site options. One option would be to connect to the existing Southern California electric transmission “grid,” while the second option would connect to a proposed substation that is planned to be built by the Victorville Municipal Utilities District on the west side of the Mojave River. Both of these electricity source options would utilize the same utility corridor.

The utility corridor right-of-way would have a typical width of approximately 100 feet. The access road contained in the corridor would be approximately 10 feet wide. The tower height of the elevated utility lines would range from 95 feet to 135 feet, depending upon land mark clearance. Tower spacing would range from 440 feet to 940 feet depending on tower height and necessary clearance. Each tower footprint would be approximately 24 square feet to 59 square feet in size, depending on the height of the tower. Typical tower configurations are shown in Appendix A. The utility towers would use a typical voltage of 230Kv transmission, with 66Kv for power distribution.

2.4.9.6 Maintenance of Way Facility

The proposed action also includes a maintenance-of-way (MOW) facility. The MOW facility would be located on a 2.4 acre site containing a 5,200 square foot building, plus tail tracks, a radio signal tower, fuel storage, and other related facilities that would serve as a headquarters for DesertXpress employees charged with daily inspection of tracks and associated facilities to ensure ongoing safe operations. See Appendix A-4 for a detailed site plan diagram of the MOW facility.

With any action alternative, the MOW facility would be located on the same land as is designated for Temporary Construction Area #9, near Baker, California.

2.4.9.7 Components of Project Construction

Temporary Construction Areas

Table 2-7 below identifies the proposed temporary construction areas (TCAs), their locations, and the segments each would serve. Several TCAs would be located in part or in whole on proposed sites for stations and/or maintenance facilities, or would otherwise be within an area the proposed alignment would permanently impact. Other TCAs are located outside any permanent impact area. Table 2-7 distinguishes between these two types of TCAs. TCA locations are shown on Figures 2-1.1 – 2-1.7.

The contractor for the proposed action would develop a construction water program to designate the water sources used during construction. As it is not anticipated that wells would be drilled to supply water, construction of the proposed action would not result in permanent impacts at any of the temporarily impacted TCAs. Water would likely be trucked in to the construction areas or supplied by existing pipelines.

Table 2-7 Temporary Construction Areas

TCA No.	Location	Within a Permanent Impact Area?	Size	Segment(s) Served
1A	At proposed site of Victorville OMSF Site 1	Partially	142.06 acres	1
1B	At proposed site of Victorville OMSF Site 2	No	135.01 acres	1
2	At proposed Victorville station site #2	Partially	14.14 acres	1
3	Near Lenwood, on northern bank of Mojave River at proposed new bridge	No	0.9 acre	2A/2B
4	Barstow, adjacent to BNSF spur line	No	14.82 acres	2A/2B
5	Yermo, east of Yermo Road/I-15 interchange	No	5.23 acres	2A/B
6	Along I-15, southwest of Field Road interchange	No	5.82 acres	3A/3B
7	Along I-15, north of Basin Road interchange	No	5.85 acres	3A/3B
8	West of Baker, between I-15 and Baker Blvd	No	1.9 acres	3A/3B
9	East of Baker, between I-15 and Baker Blvd	Yes	9.63 acres	3A/3B
10	North of I-15 at Cima Road	No	5.59 acres	3A/3B
11	West of I-15 at Yates Well Road	No	10.22 acres	4A
12	Northwest of I-15/Yates Well Road interchange	No	10.42 acres	4B
13	South of Sloan Road near UPRR undercrossing of I-15	No	11.49 acres	5A/5B
14	Along UPRR Corridor @ Le Baron Avenue in unincorporated Clark County	No	32.49 acres	Segment 6, Option C
15	South of West Twain Avenue at West Flamingo Road; site of proposed Central Station A	Yes	10.32 acres	6A/6B, Option C
16	Between Russell Road and Hacienda; site of proposed Southern Station	Yes	57.09 acres	6A, 6B
17	South of Bonneville Avenue in City of Las Vegas; site of proposed Downtown Station	Yes	24.08 acres	7A, 7B, Option C
18 + 19	At openings of proposed tunnel #1 northeast of Mountain Pass	No	2.15 acres	4B
20 + 21	At openings of proposed tunnel #2 northeast of Mountain Pass	No	2.22 acres	4B
22	West of I-15 between Polaris Street and Aldebaran Avenue at site of proposed Central Station B	Yes	10.0	7A/7B

Source: DesertXpress, 2006-2008.

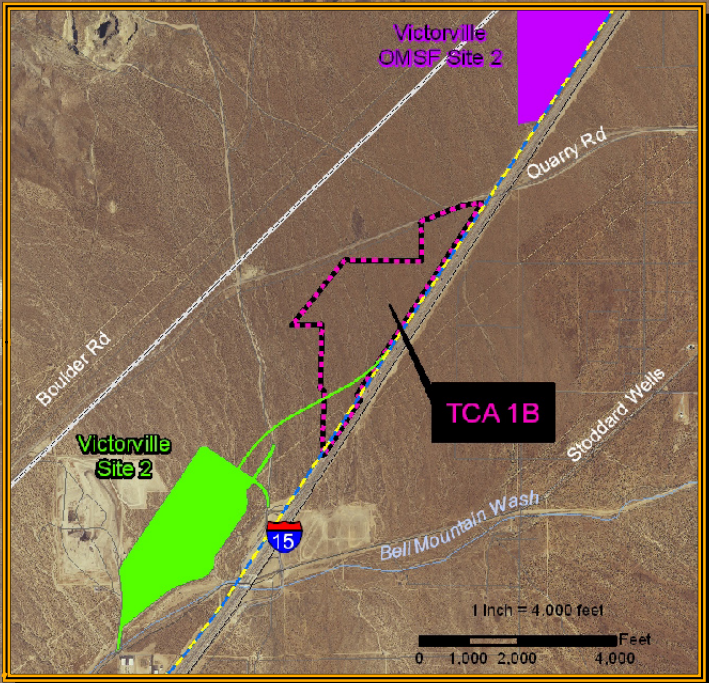
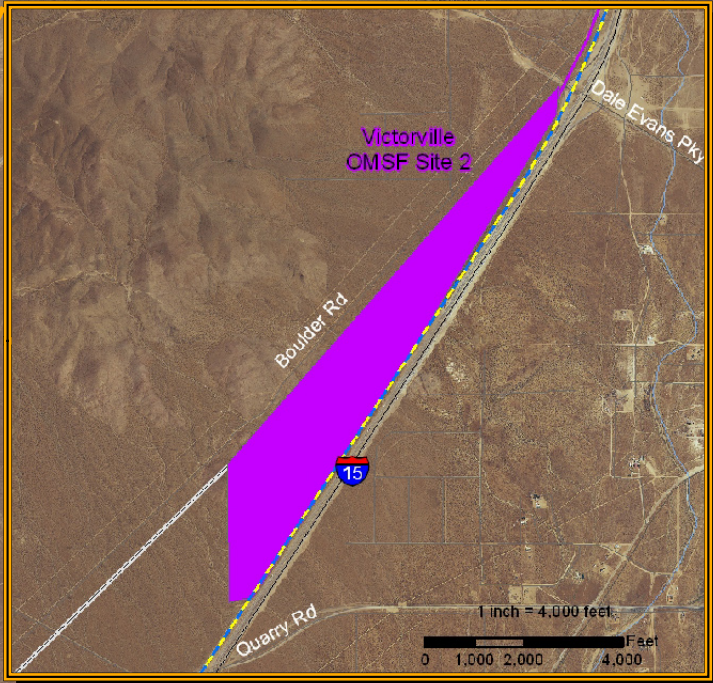
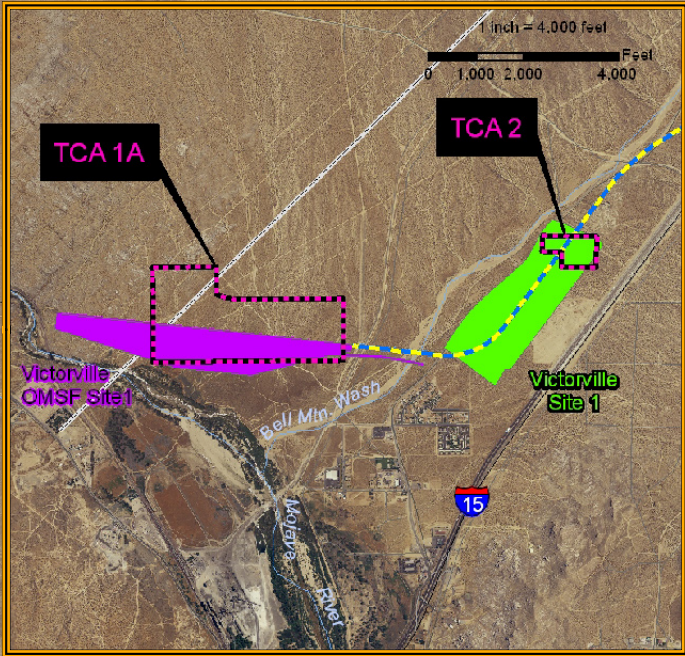
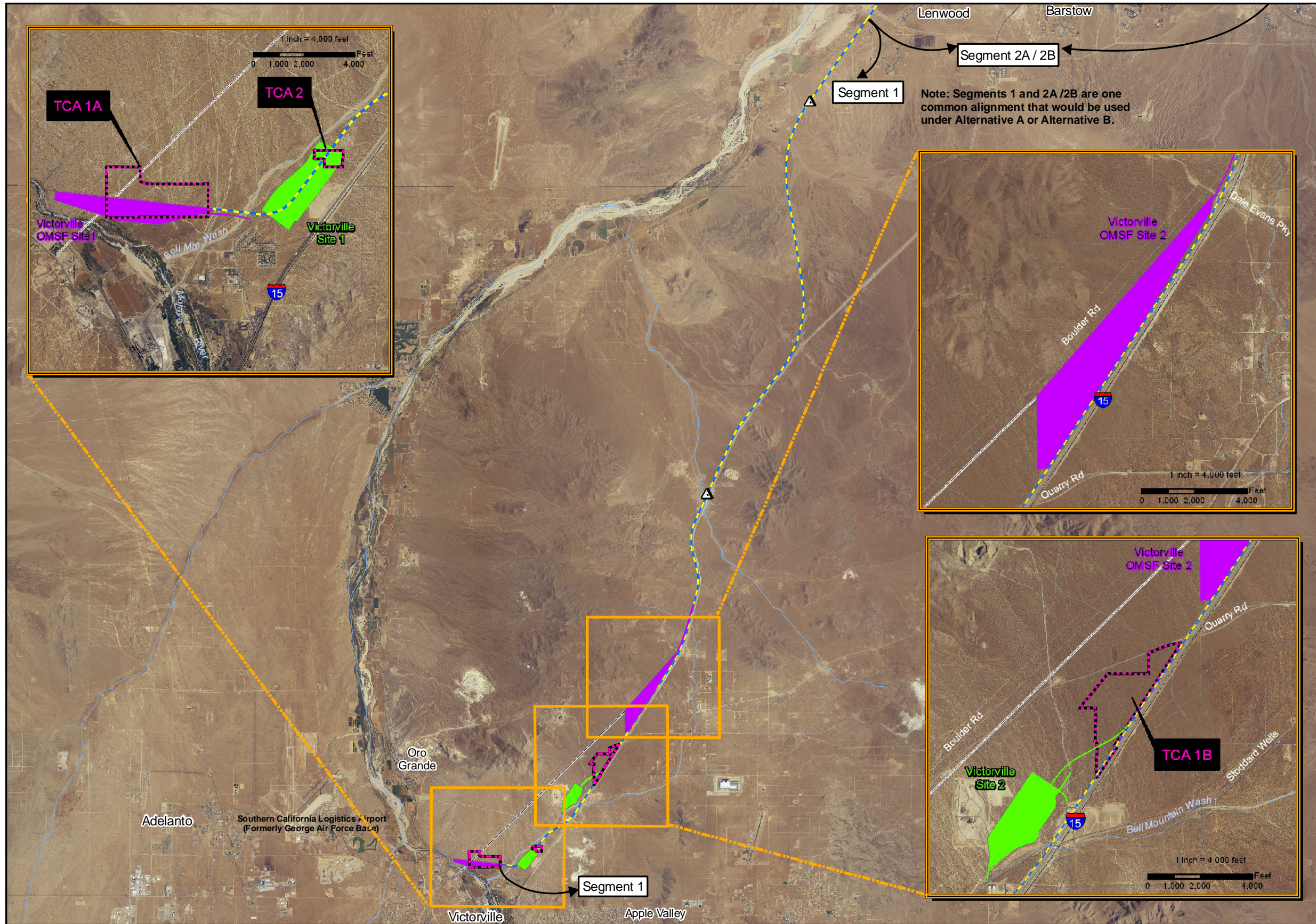

Legend

DesertXpress Alignments

- Alternative A
- Alternative B
- Option C

Ancillary Facility Sites

- Station Options
- Maintenance Facility Options
- Temporary Construction Areas (TCAs)
- Autotransformer (EMU Option Only)
- Electric Utility Corridor (EMU Option Only)

Note: Please refer to Appendix A, which includes plan and profile drawings at 1"1000", seven fold-out maps depicting the DesertXpress project in full, and detailed site plans for all ancillary facilities.

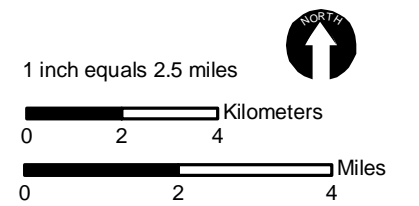

Source: DesertXpress 2007, ESRI 2005, NAIP

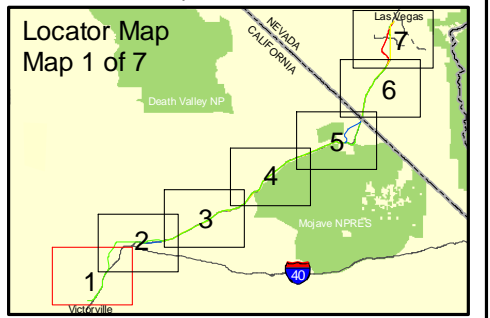

DesertXpress Project EIS

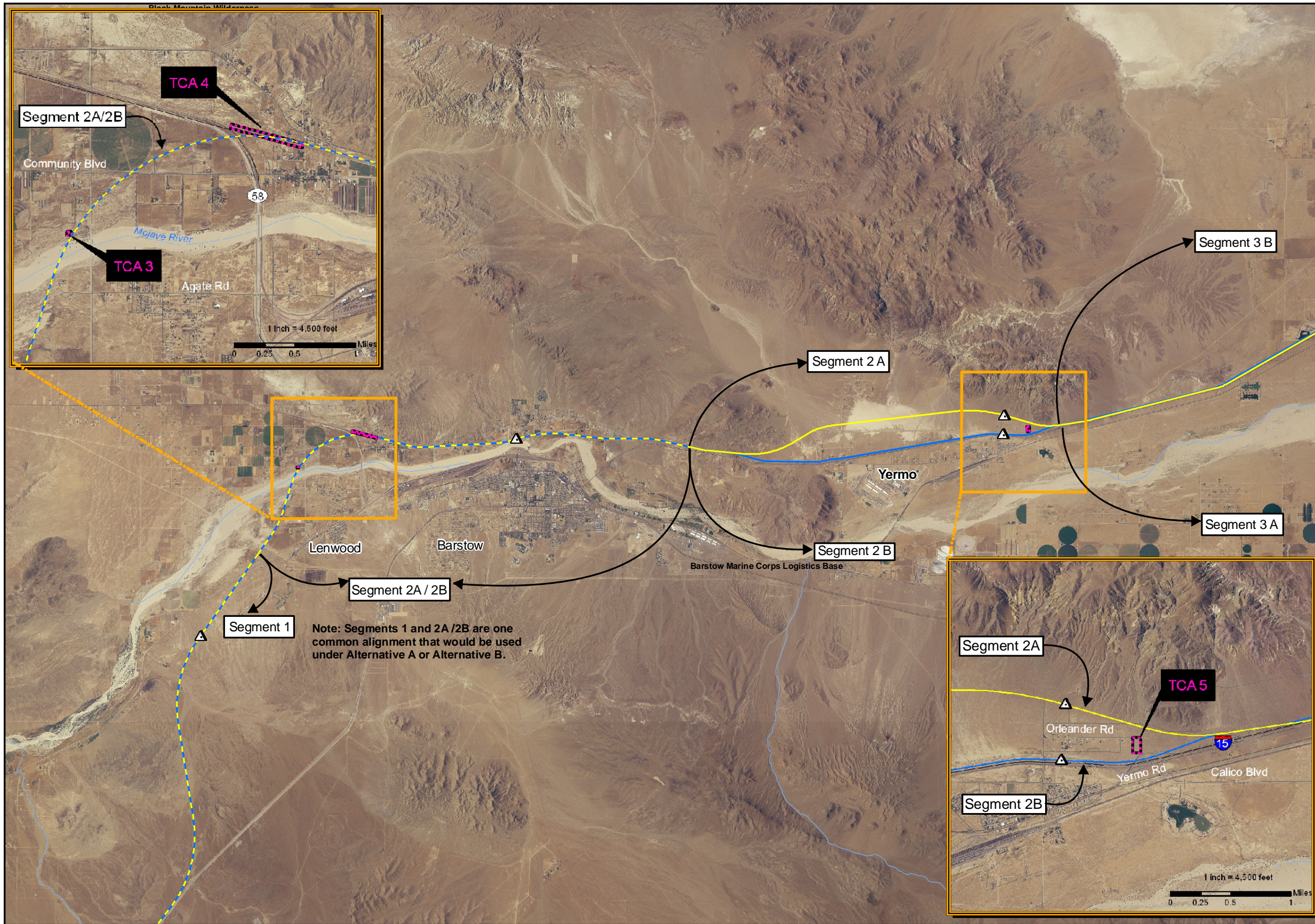

Note: Segments 1 and 2A / 2B are one common alignment that would be used under Alternative A or Alternative B.

Legend

DesertXpress Alignments

- Alternative A
- Alternative B
- Option C

Ancillary Facility Sites

- Station Options
- Maintenance Facility Options
- Temporary Construction Areas (TCAs)
- Autotransformer (EMU Option Only)
- Electric Utility Corridor (EMU Option Only)

Note: Please refer to Appendix A, which includes plan and profile drawings at 1"=1000', seven fold-out maps depicting the DesertXpress project in full, and detailed site plans for all ancillary facilities.

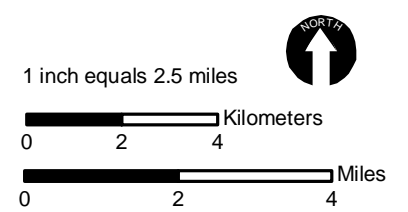

Source: DesertXpress 2007, ESRI 2005, NAIP

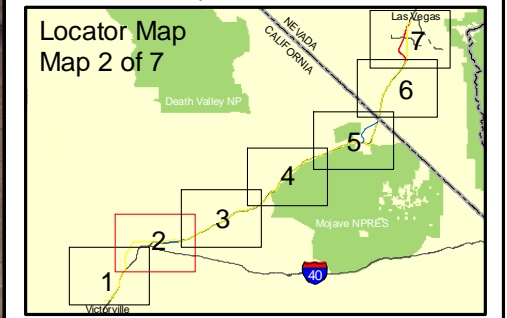

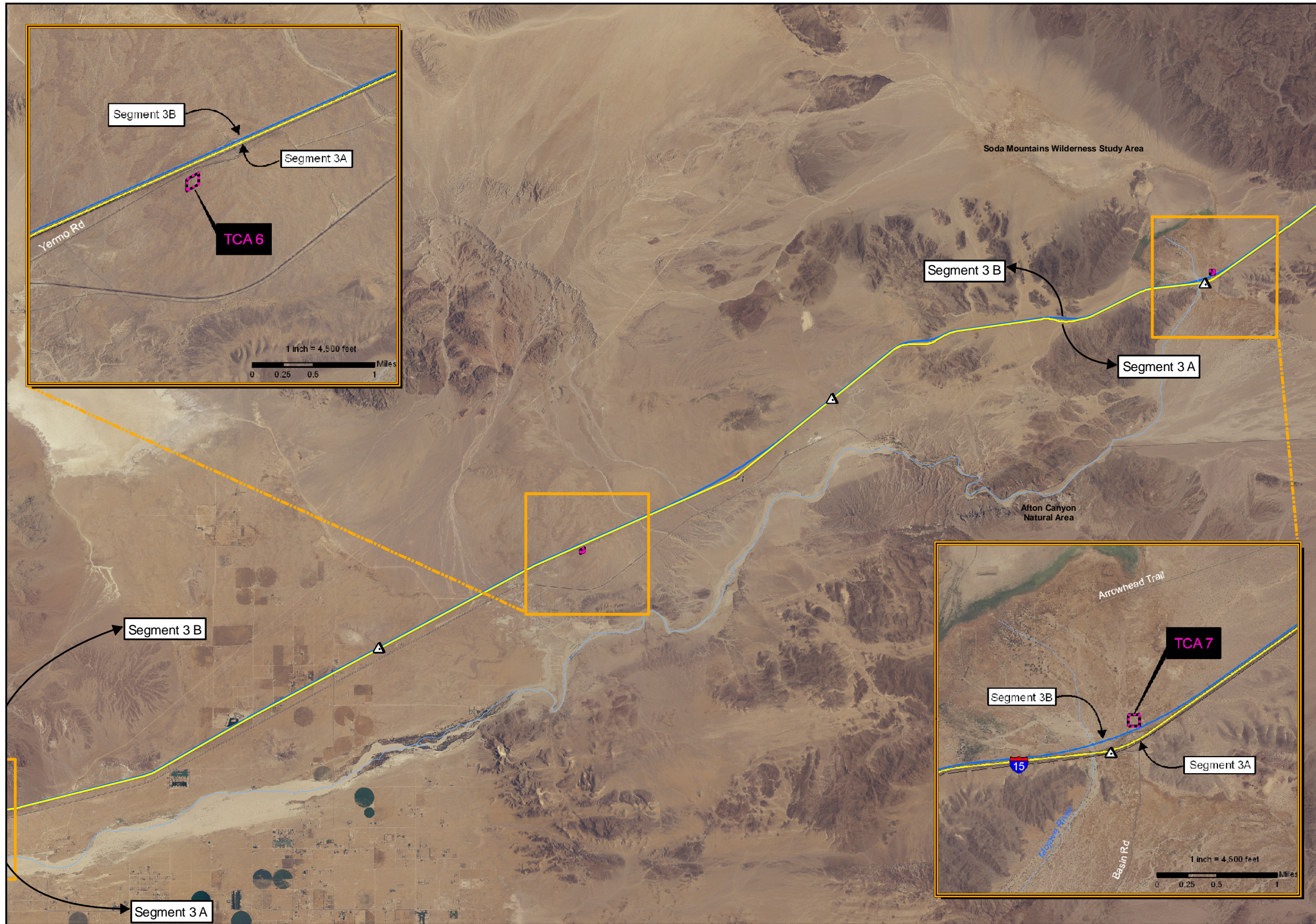

Legend

DesertXpress Alignments

- Alternative A
- Alternative B
- Option C

Ancillary Facility Sites

- Station Options
- Maintenance Facility Options
- Temporary Construction Areas (TCAs)
- Autotransformer (EMU Option Only)
- Electric Utility Corridor (EMU Option Only)

Note: Please refer to Appendix A, which includes plan and profile drawings at 1":1000', seven fold-out maps depicting the DesertXpress project in full, and detailed site plans for all ancillary facilities.

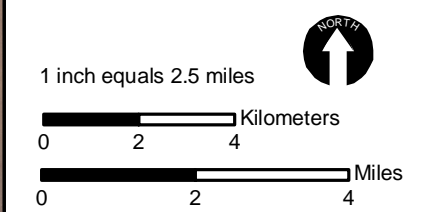

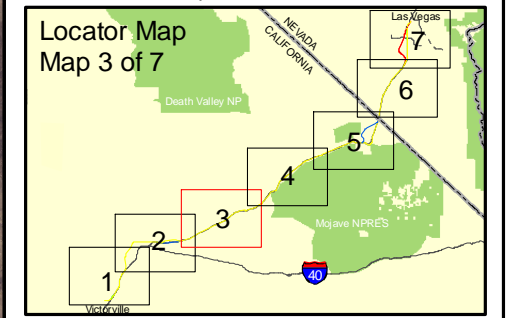

Source: DesertXpress 2007, ESRI 2005, NAIP

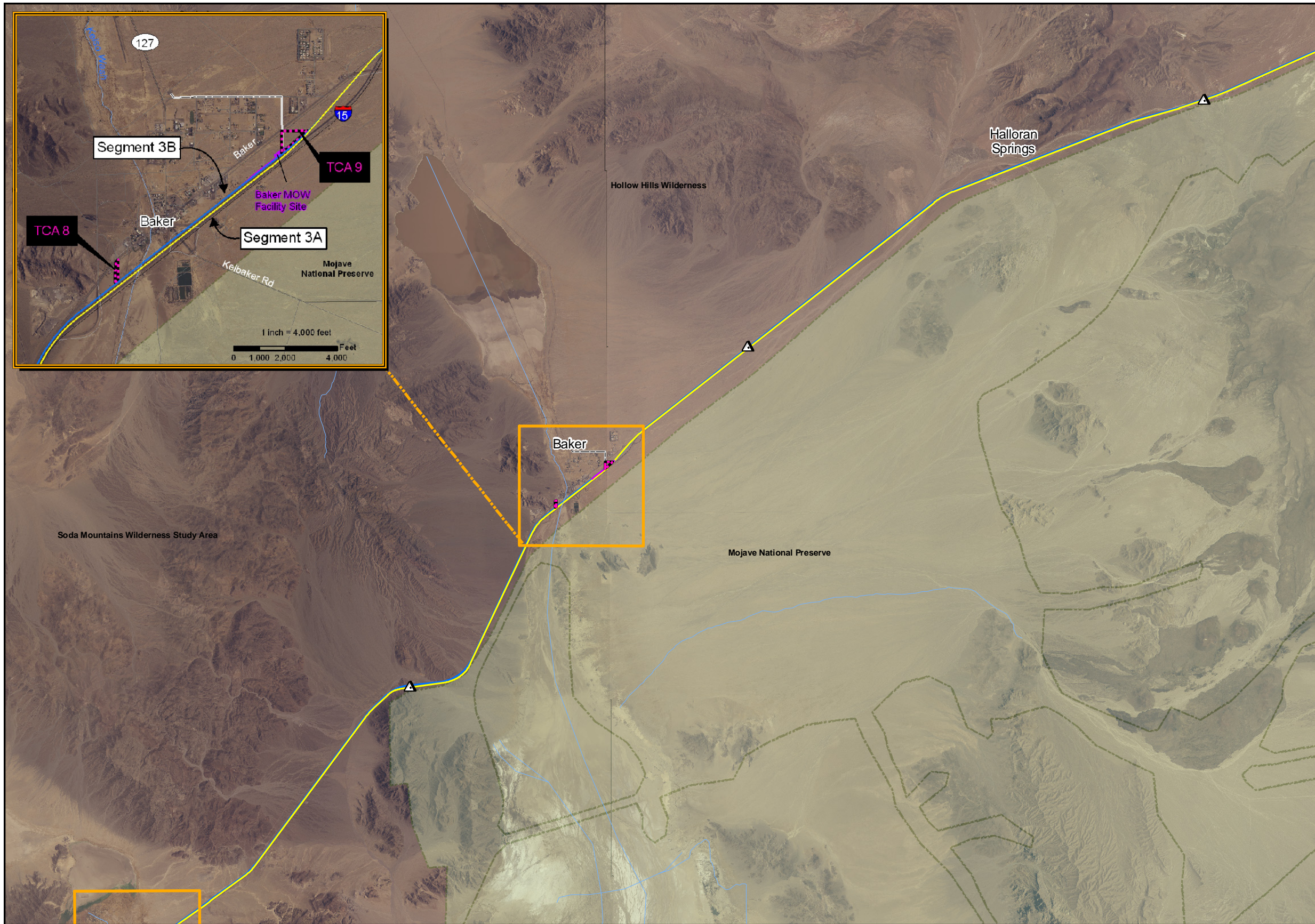







Legend

DesertXpress Alignments

-  Alternative A
-  Alternative B
-  Option C

Ancillary Facility Sites

-  Station Options
-  Maintenance Facility Options
-  Temporary Construction Areas (TCAs)
-  Autotransformer (EMU Option Only)
-  Electric Utility Corridor (EMU Option Only)

Note: Please refer to Appendix A, which includes plan and profile drawings at 1"1000', seven fold-out maps depicting the DesertXpress project in full, and detailed site plans for all ancillary facilities.

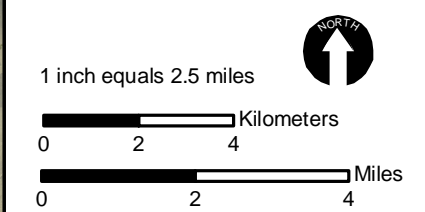

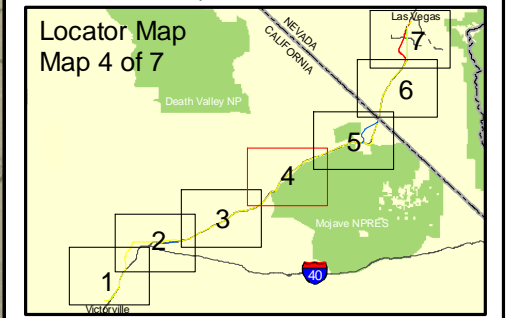

Source: DesertXpress 2007, ESRI 2005, NAIP

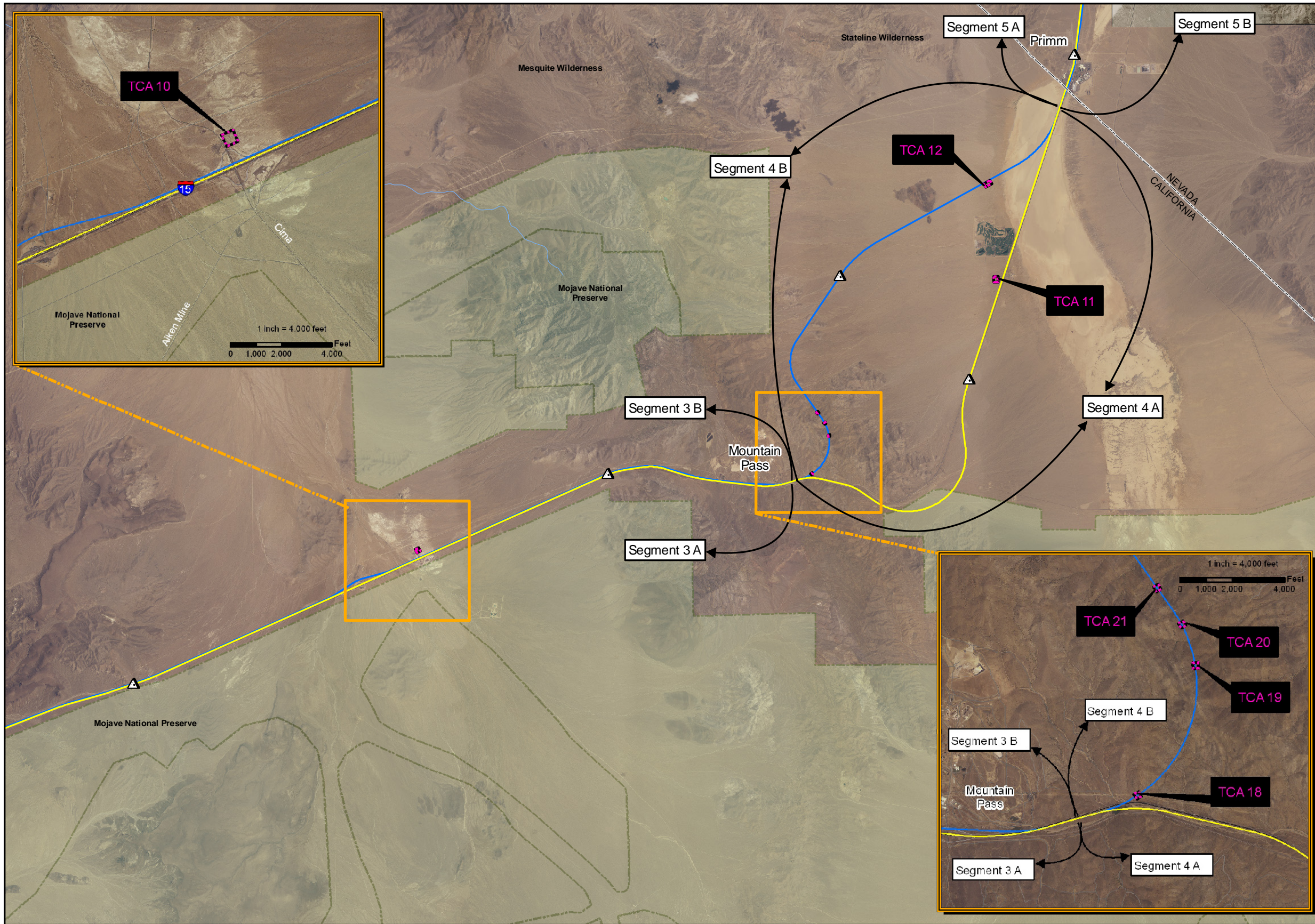







Legend

DesertXpress Alignments

-  Alternative A
-  Alternative B
-  Option C

Ancillary Facility Sites

-  Station Options
-  Maintenance Facility Options
-  Temporary Construction Areas (TCAs)
-  Autotransformer (EMU Option Only)
-  Electric Utility Corridor (EMU Option Only)

Note: Please refer to Appendix A, which includes plan and profile drawings at 1"=1000', seven fold-out maps depicting the DesertXpress project in full, and detailed site plans for all ancillary facilities.

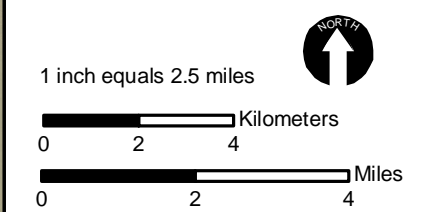

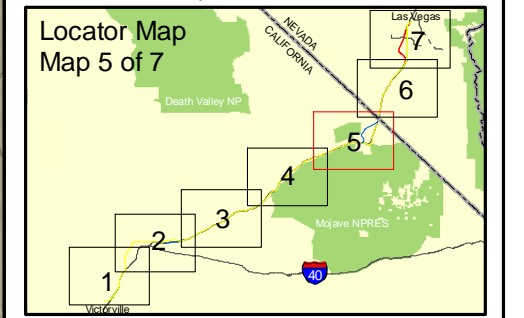

Source: DesertXpress 2007, ESRI 2005, NAIP

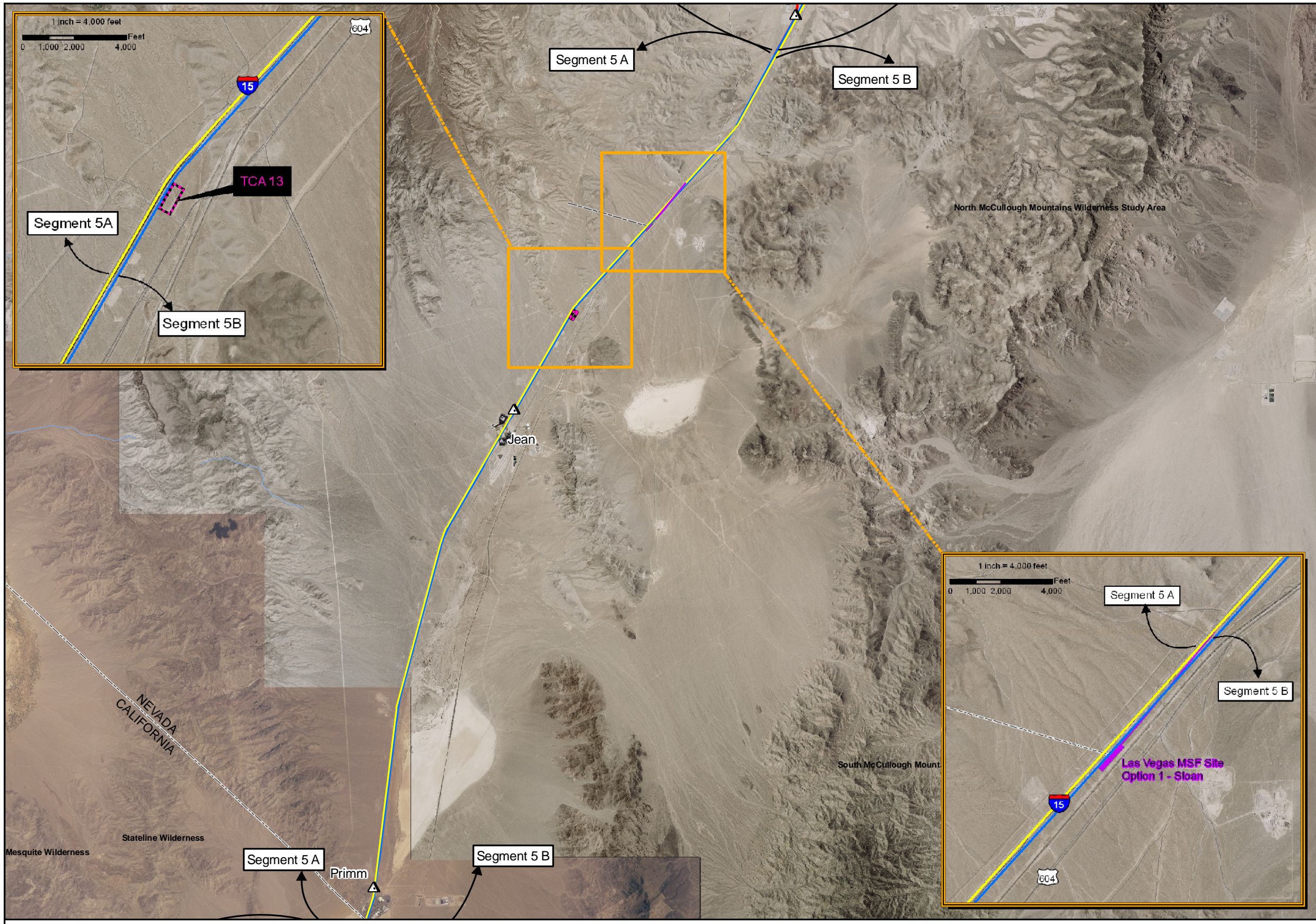







Legend

DesertXpress Alignments

-  Alternative A
-  Alternative B
-  Option C

Ancillary Facility Sites

-  Station Options
-  Maintenance Facility Options
-  Temporary Construction Areas (TCAs)
-  Autotransformer (EMU Option Only)
-  Electric Utility Corridor (EMU Option Only)

Note: Please refer to Appendix A, which includes plan and profile drawings at 1"1000', seven fold-out maps depicting the DesertXpress project in full, and detailed site plans for all ancillary facilities.

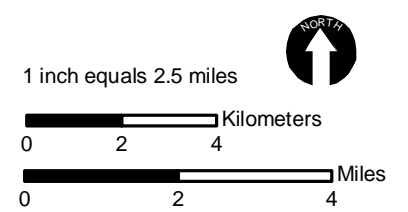

Source: DesertXpress 2007, ESRI 2005, NAIP

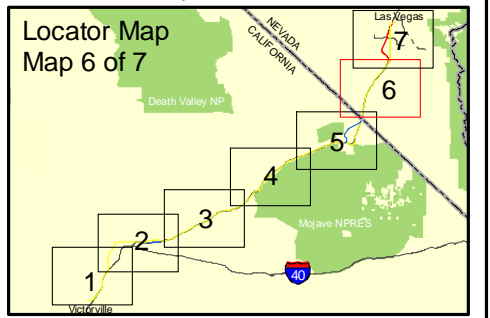

DesertXpress Project EIS

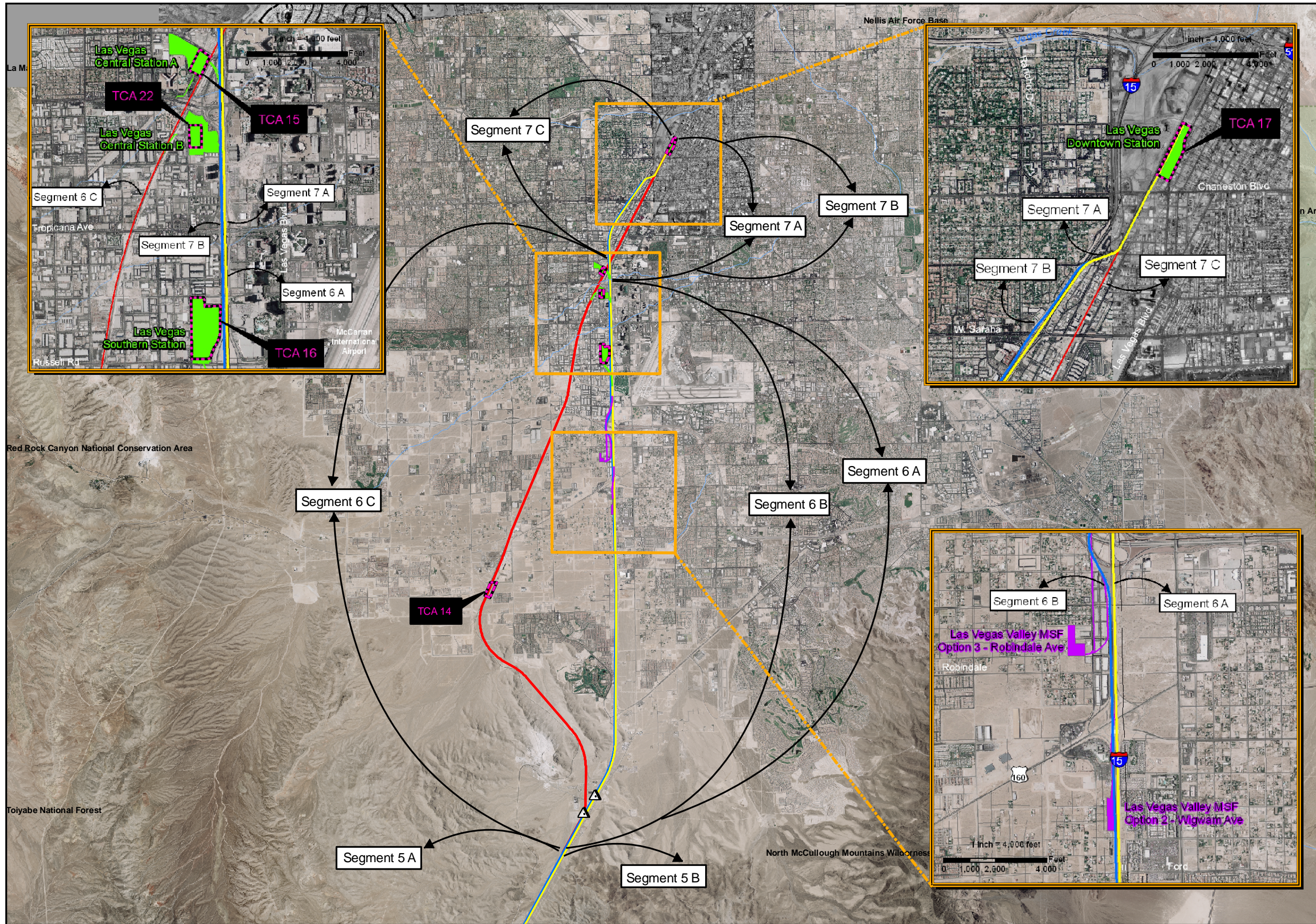

Legend

DesertXpress Alignments

- Alternative A
- Alternative B
- Option C

Ancillary Facility Sites

- Station Options
- Maintenance Facility Options
- Temporary Construction Areas (TCAs)
- Autotransformer (EMU Option Only)
- Electric Utility Corridor (EMU Option Only)

Note: Please refer to Appendix A, which includes plan and profile drawings at 1"1000", seven fold-out maps depicting the DesertXpress project in full, and detailed site plans for all ancillary facilities.

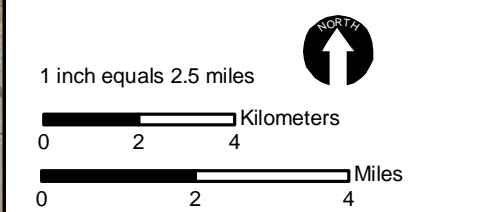

Source: DesertXpress 2007, ESRI 2005, NAIP

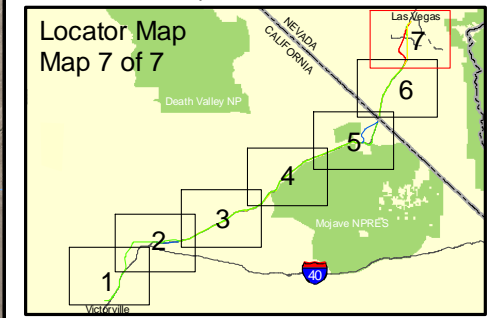

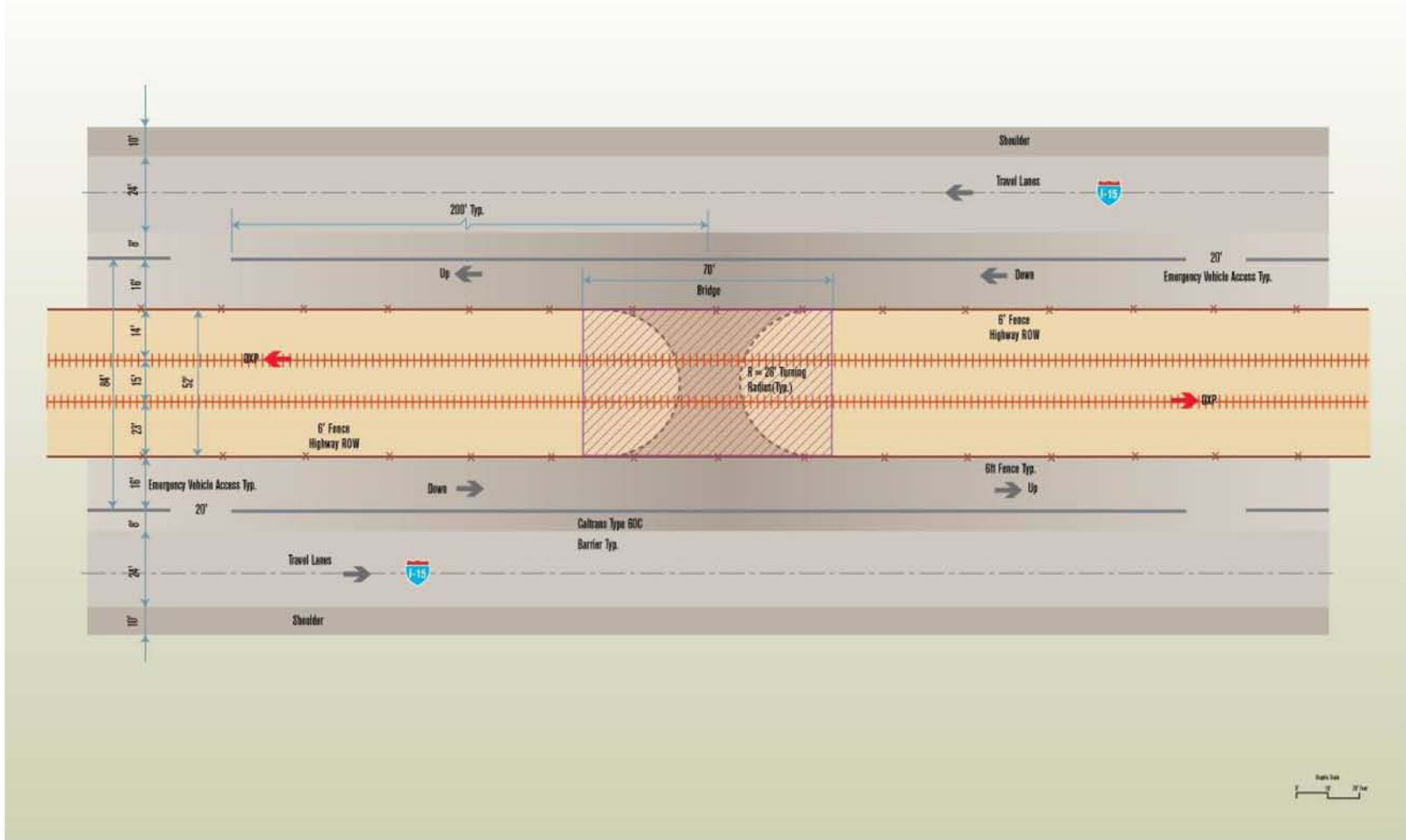

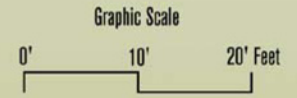
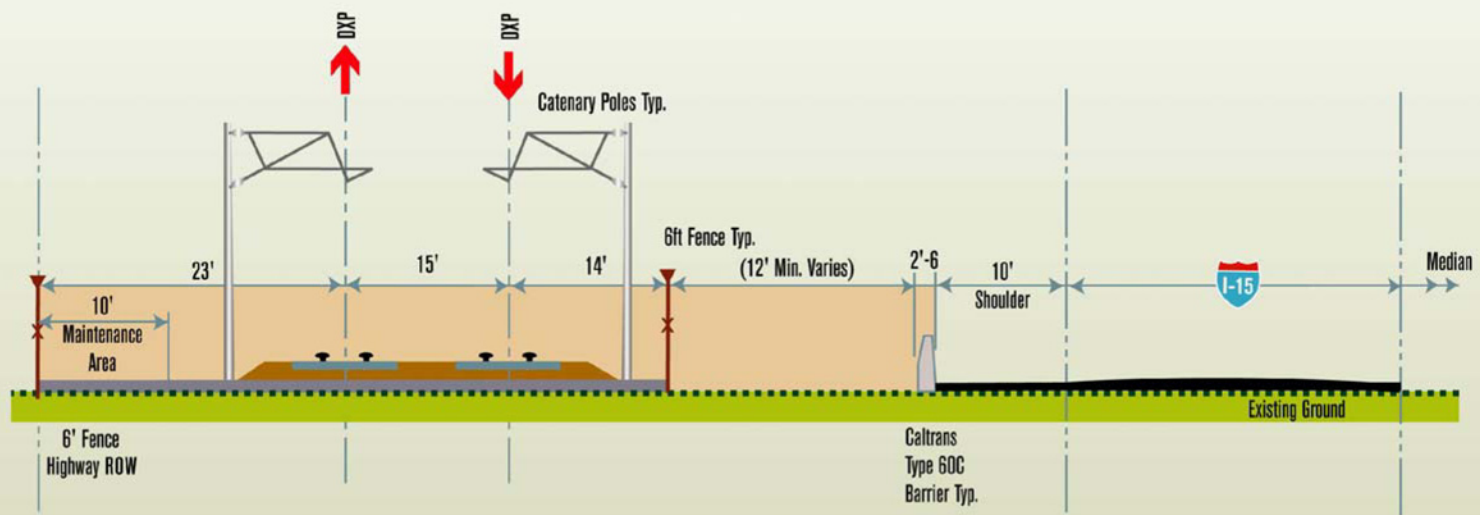

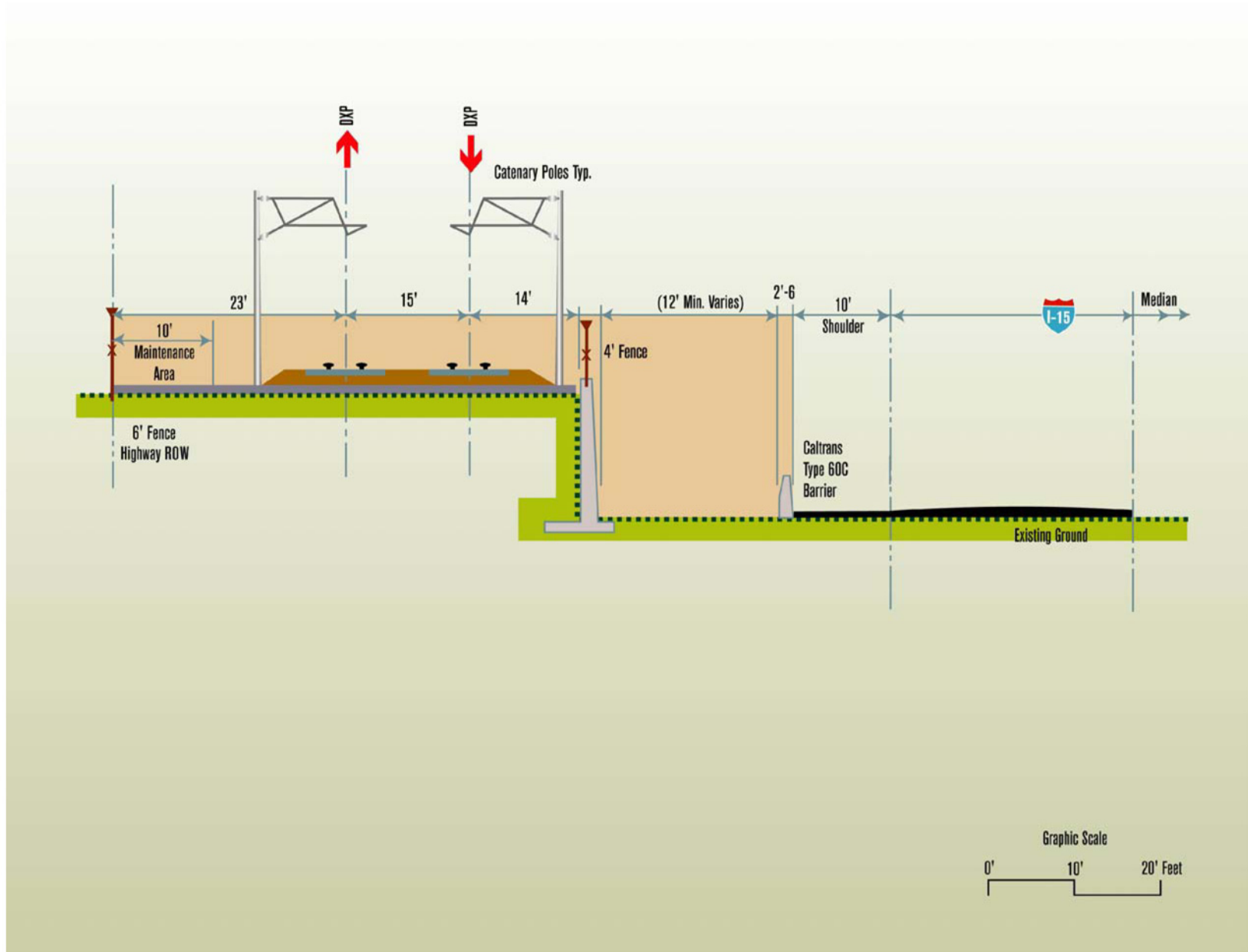

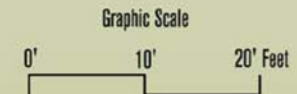
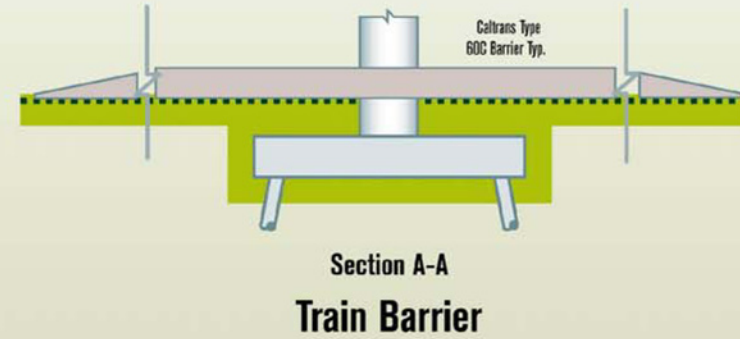
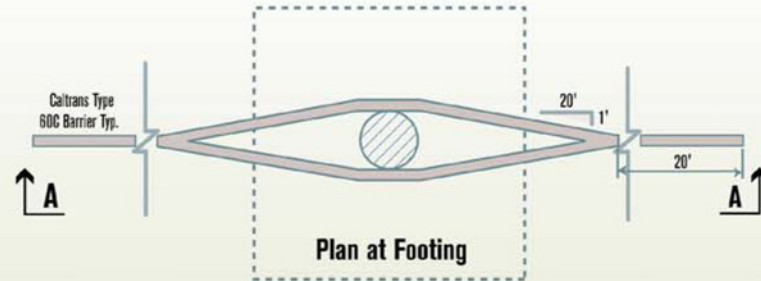
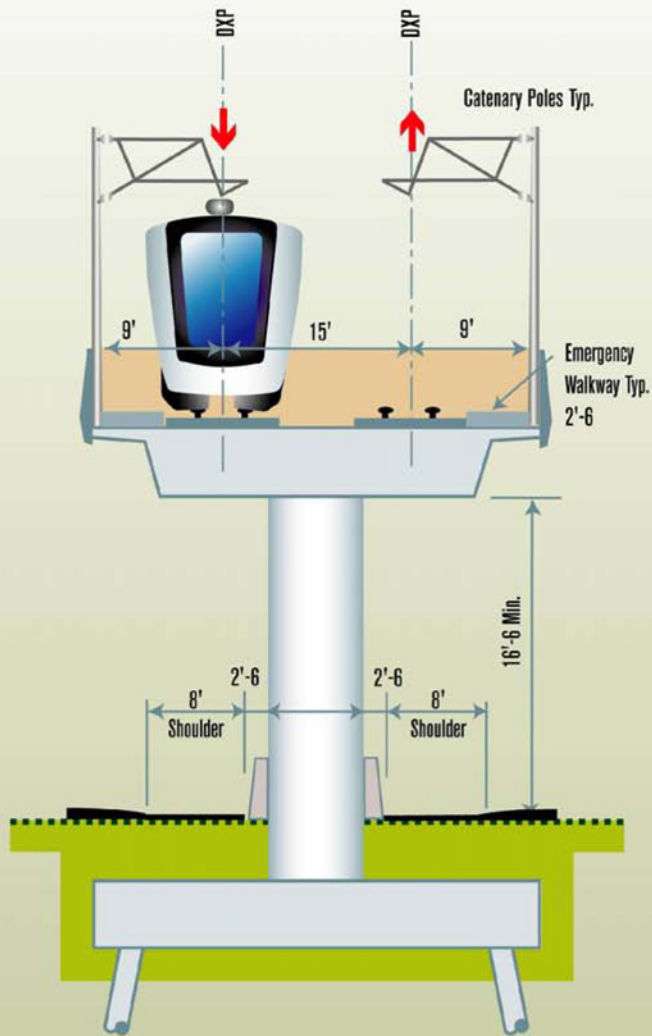

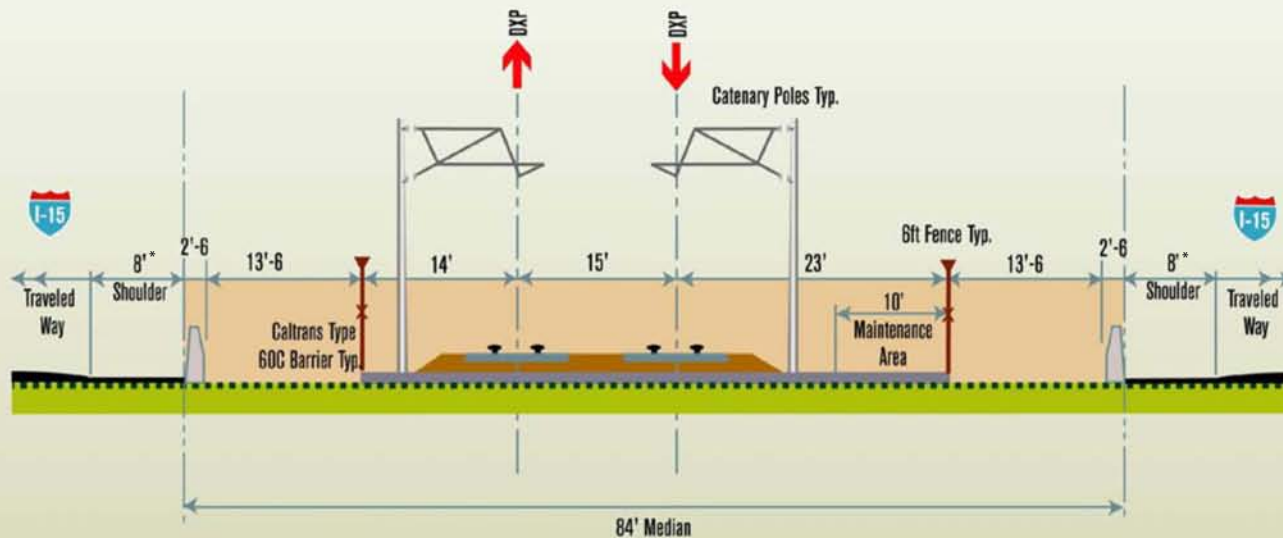

Note:
 * Shoulders would be constructed in accordance with Caltrans design standards. Within California, roadway shoulders would be 10 feet in width.

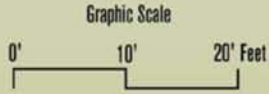

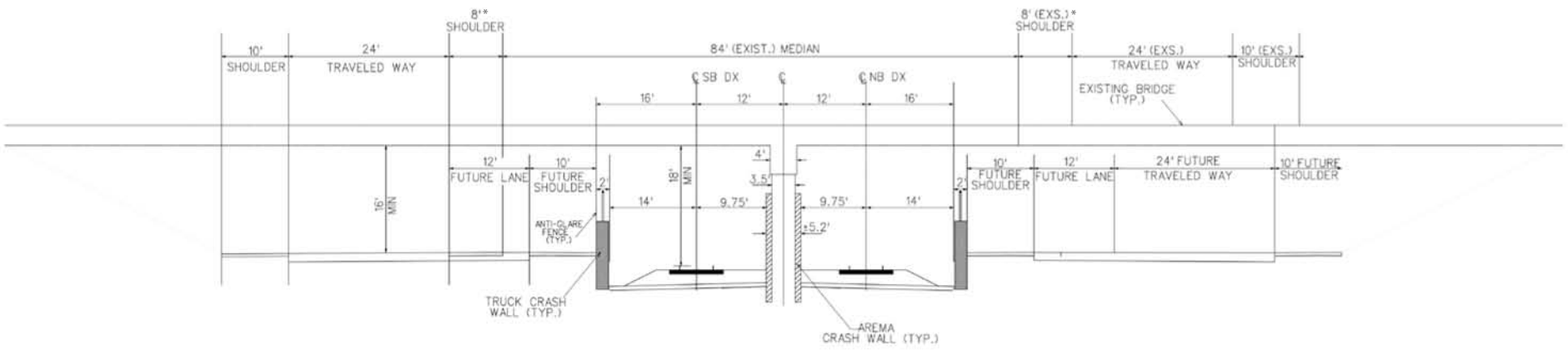
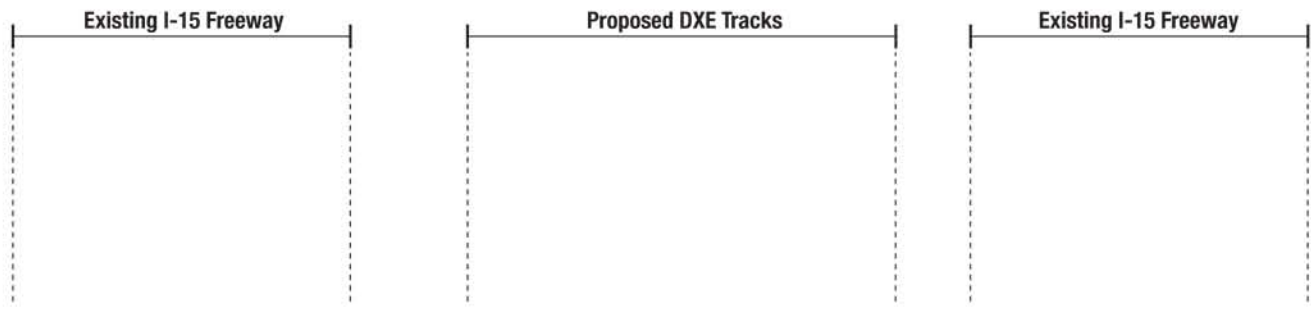

Note:
 * Shoulders would be constructed in accordance with Caltrans design standards. Within California, roadway shoulders would be 10 feet in width.

NOT TO SCALE

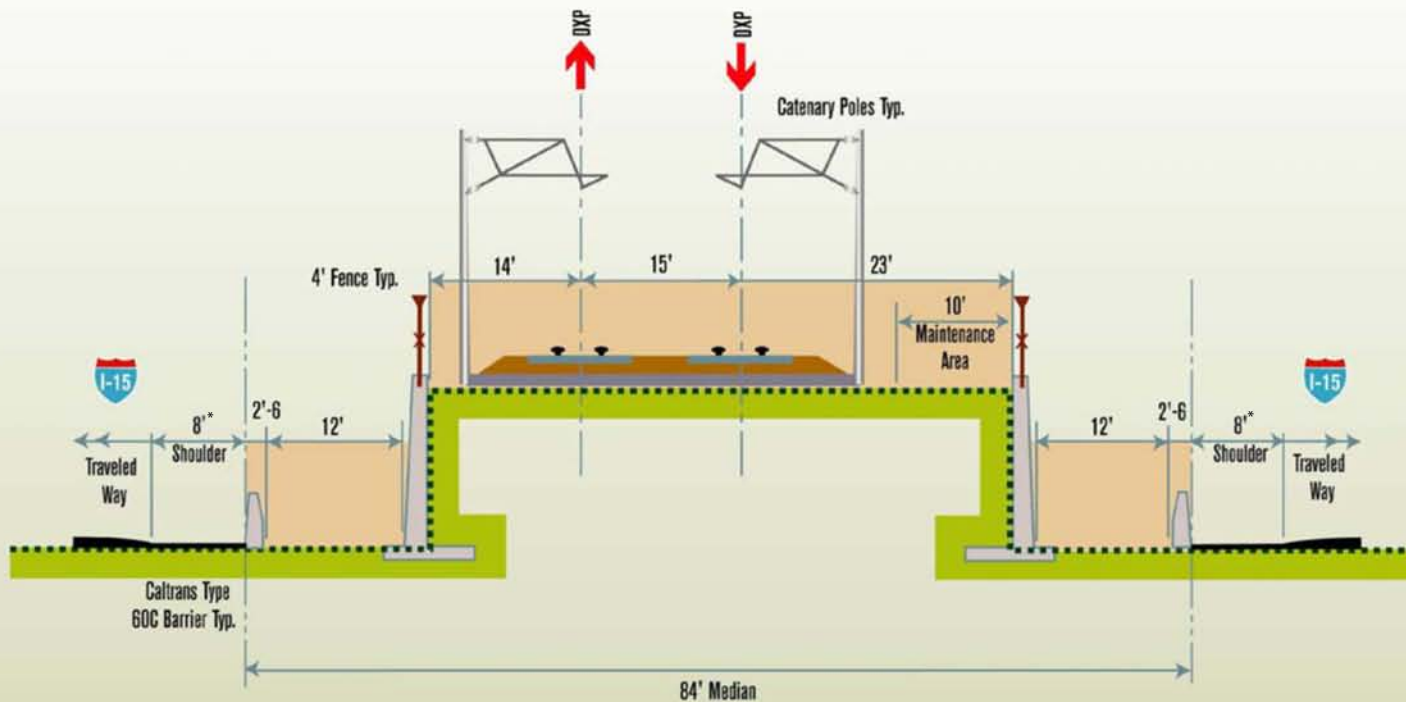

Note:
 * Shoulders would be constructed in accordance with Caltrans design standards. Within California, roadway shoulders would be 10 feet in width.

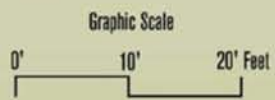

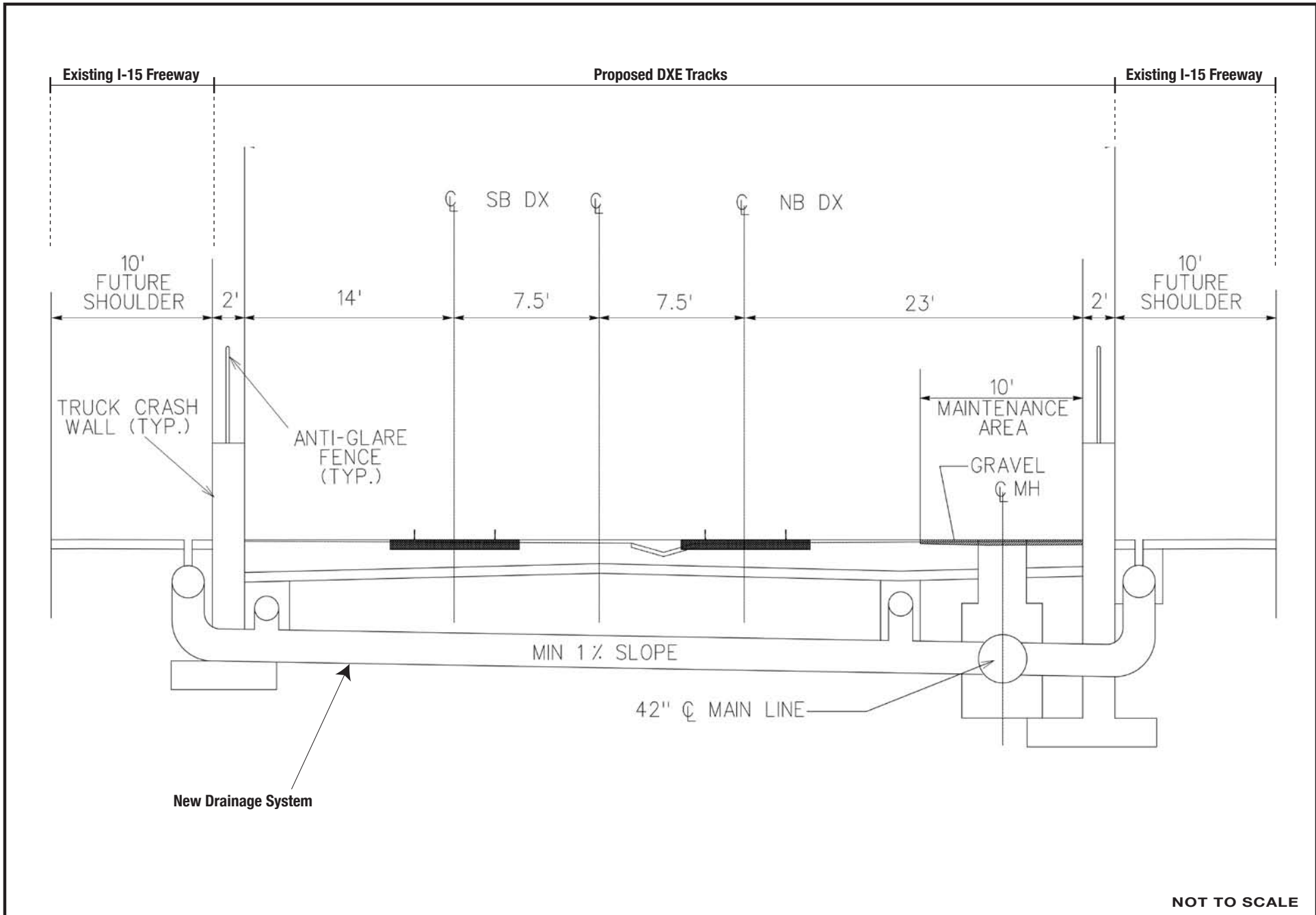

NOT TO SCALE

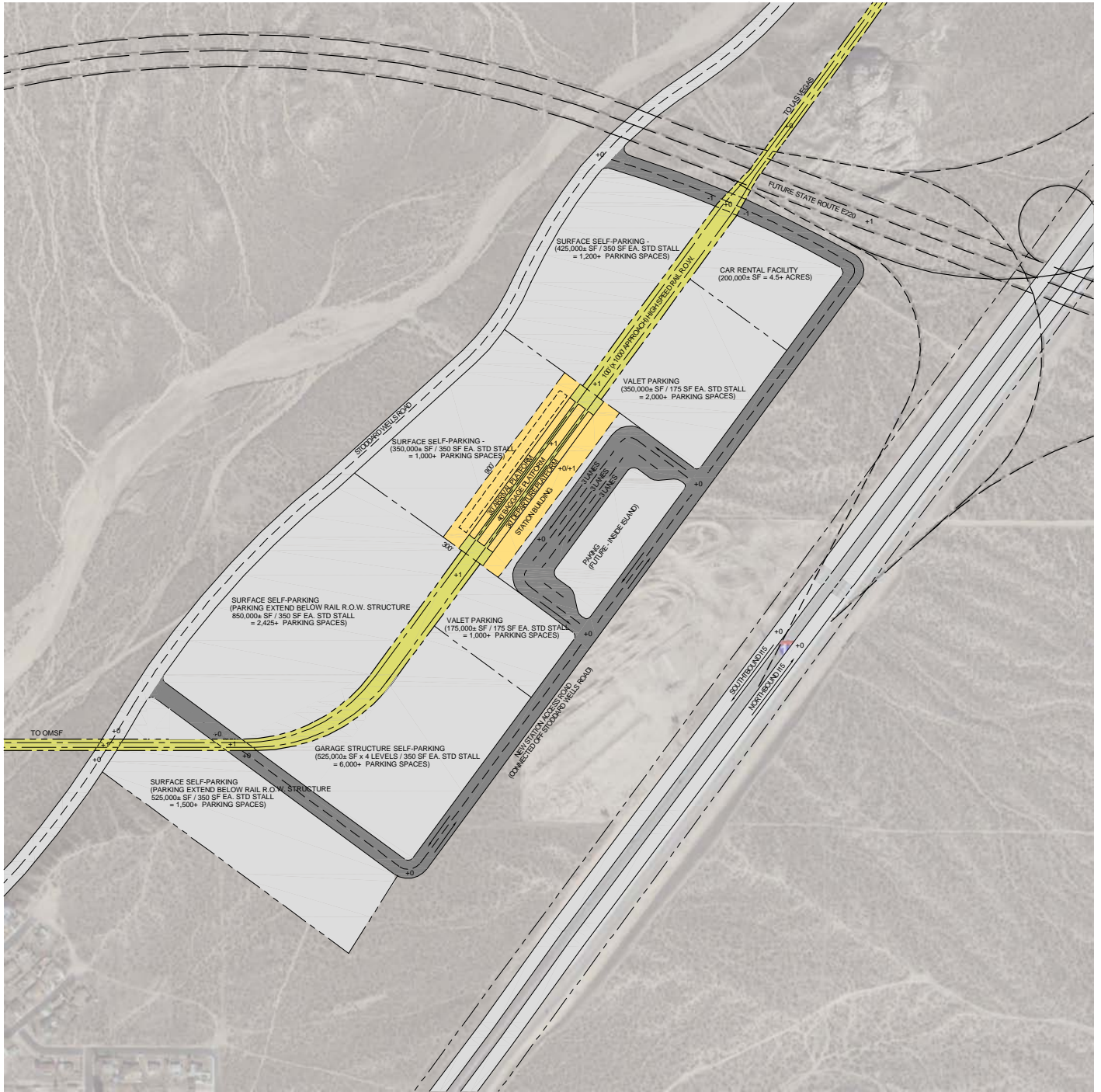

Note: Please refer to Appendix A, which includes plan and profile drawings at 1":1000', seven fold-out maps depicting the DesertXpress project in full, and detailed site plans for all ancillary facilities.

NOT TO SCALE

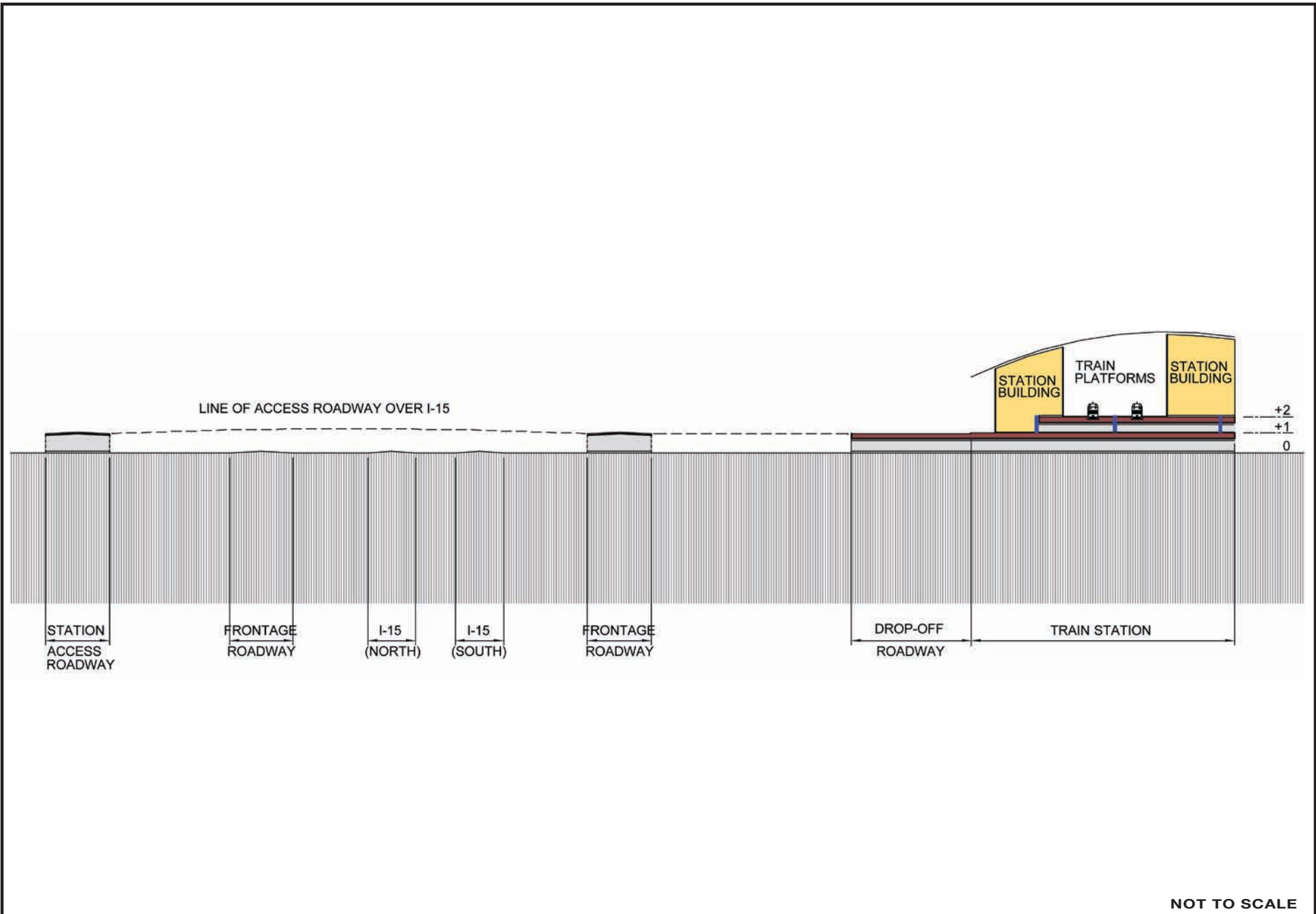

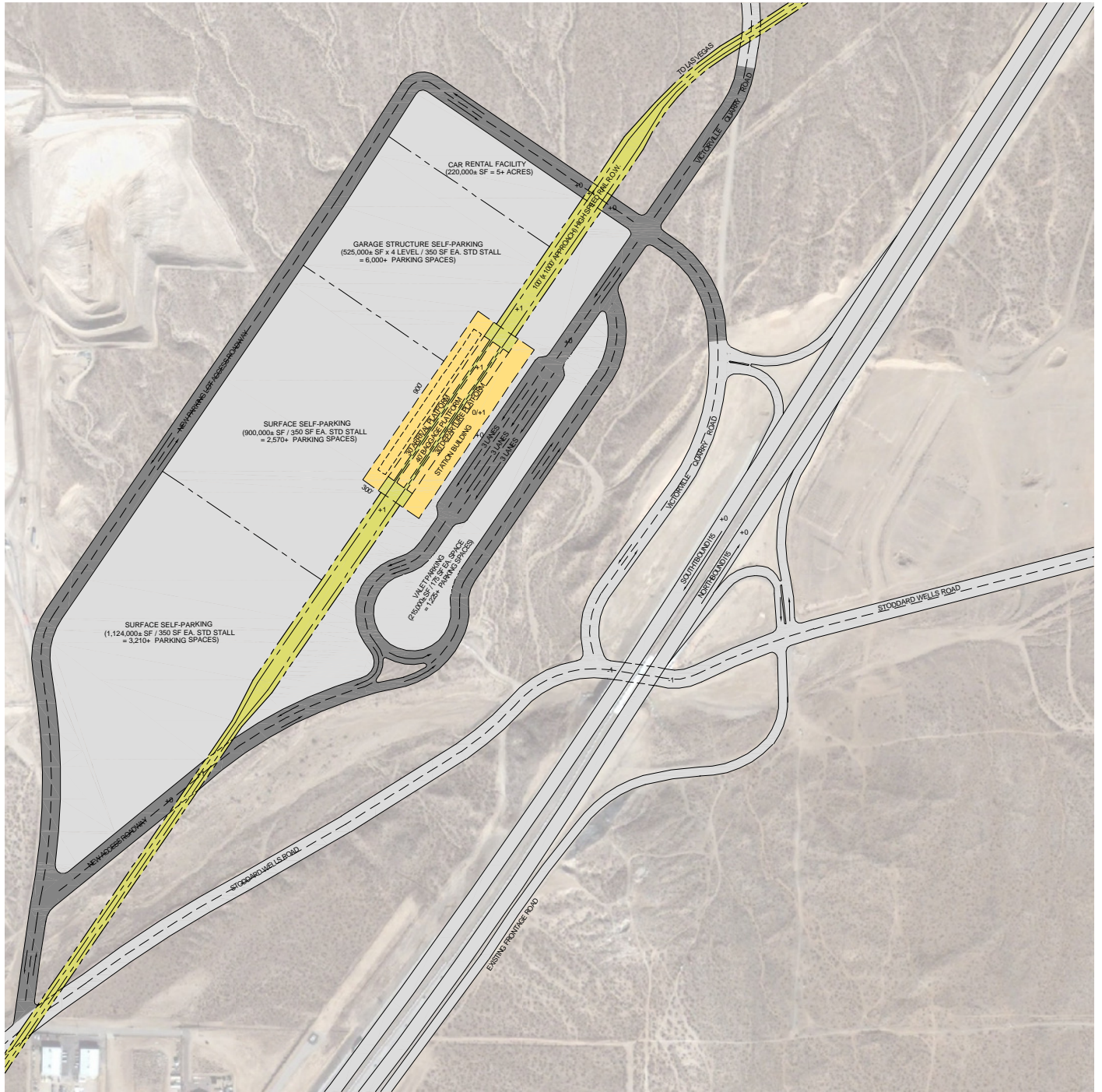

NOT TO SCALE

OUTLINE OF STODDARD WELLS ROAD
PASSING UNDER I-15 (BEYOND)

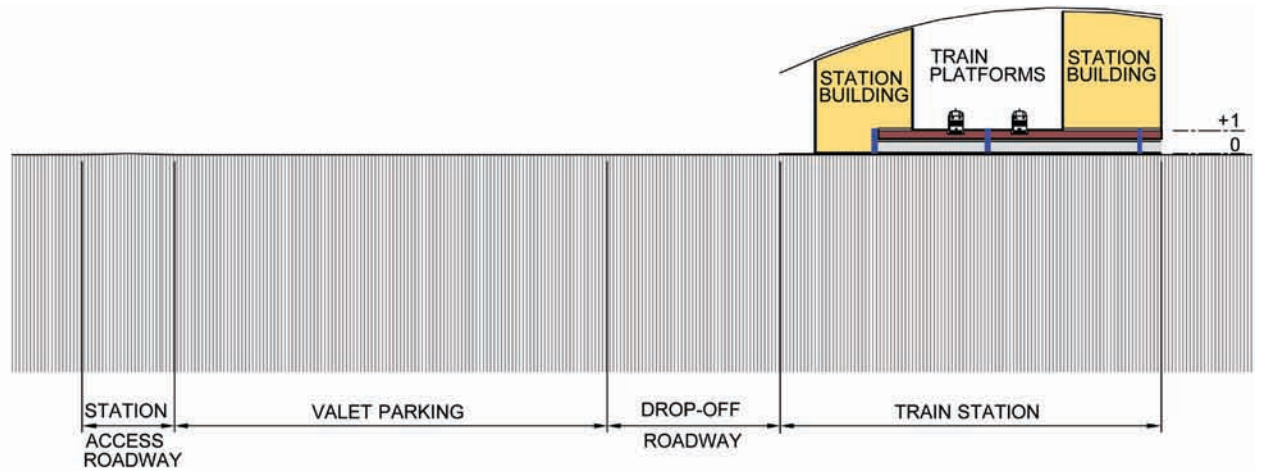
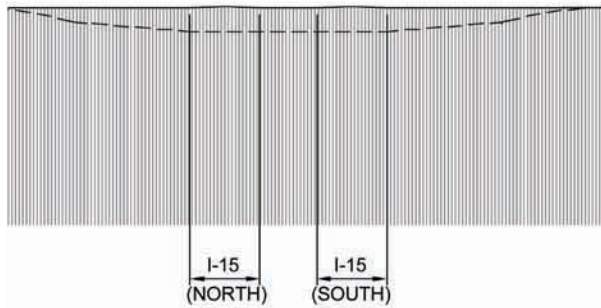

NOT TO SCALE

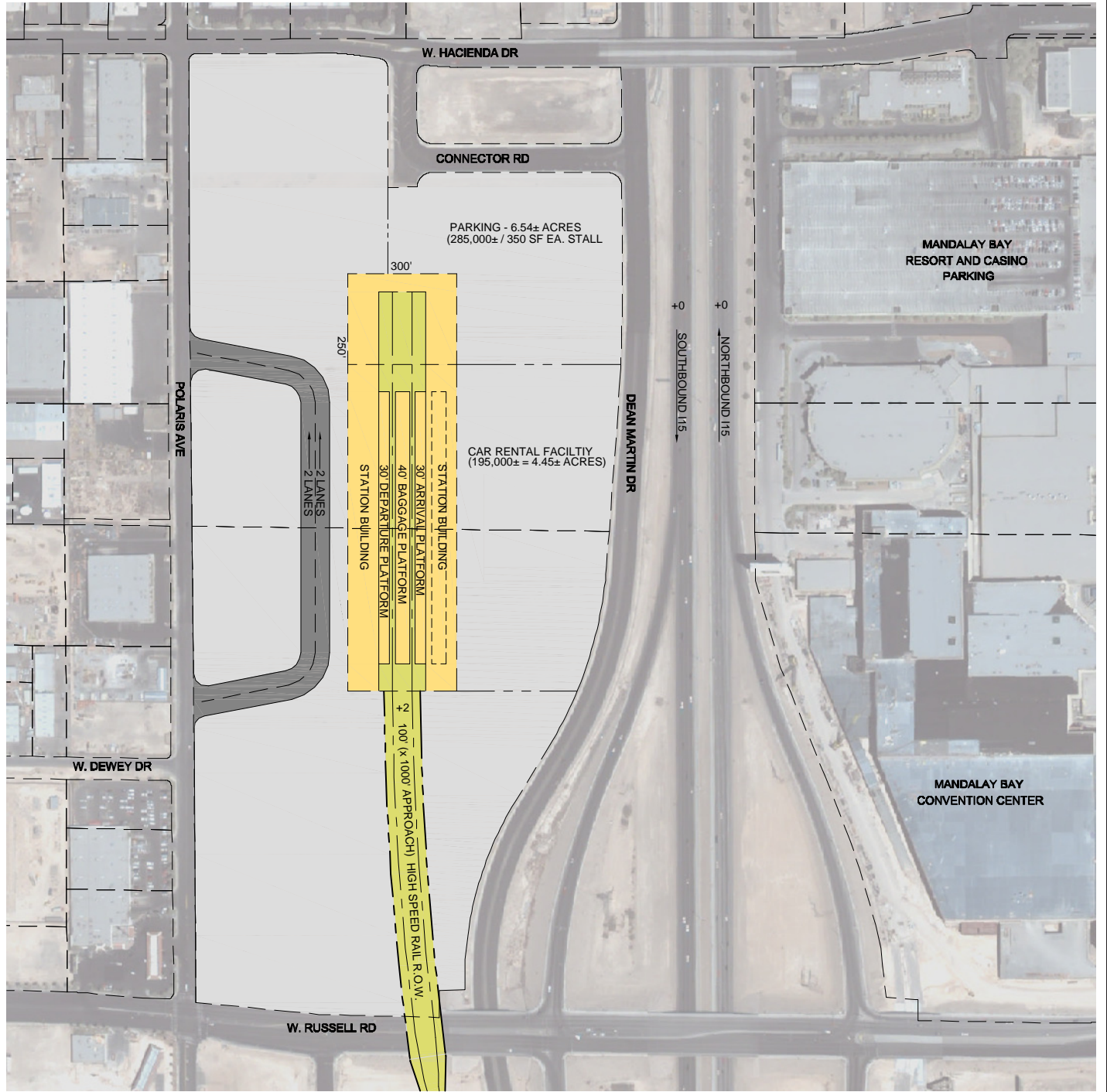

NOT TO SCALE

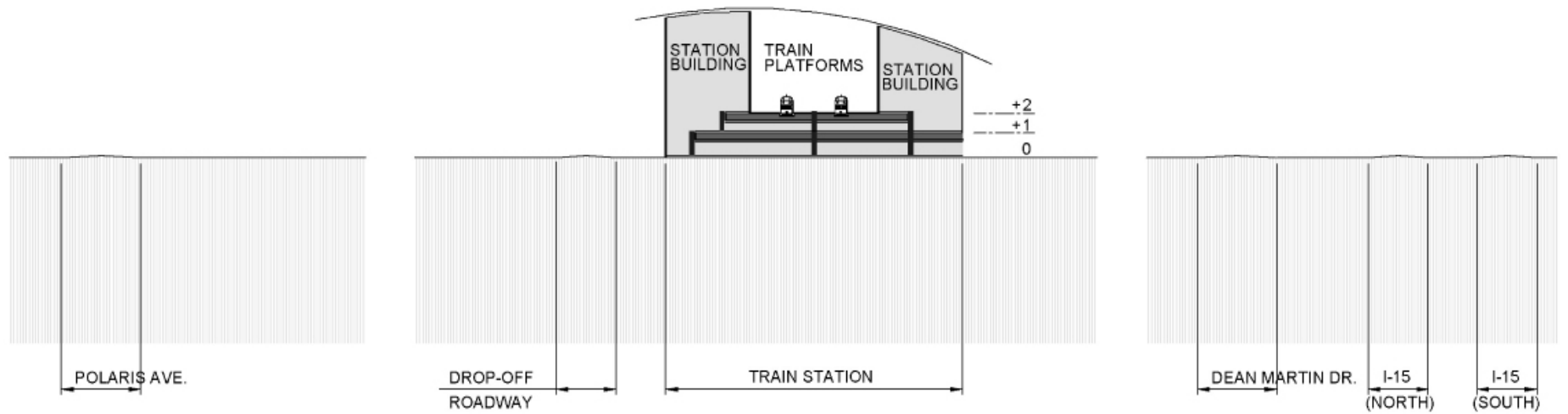

NOT TO SCALE



Note: Please refer to Appendix A, which includes plan and profile drawings at 1":1000', seven fold-out maps depicting the DesertXpress project in full, and detailed site plans for all ancillary facilities.

NOT TO SCALE

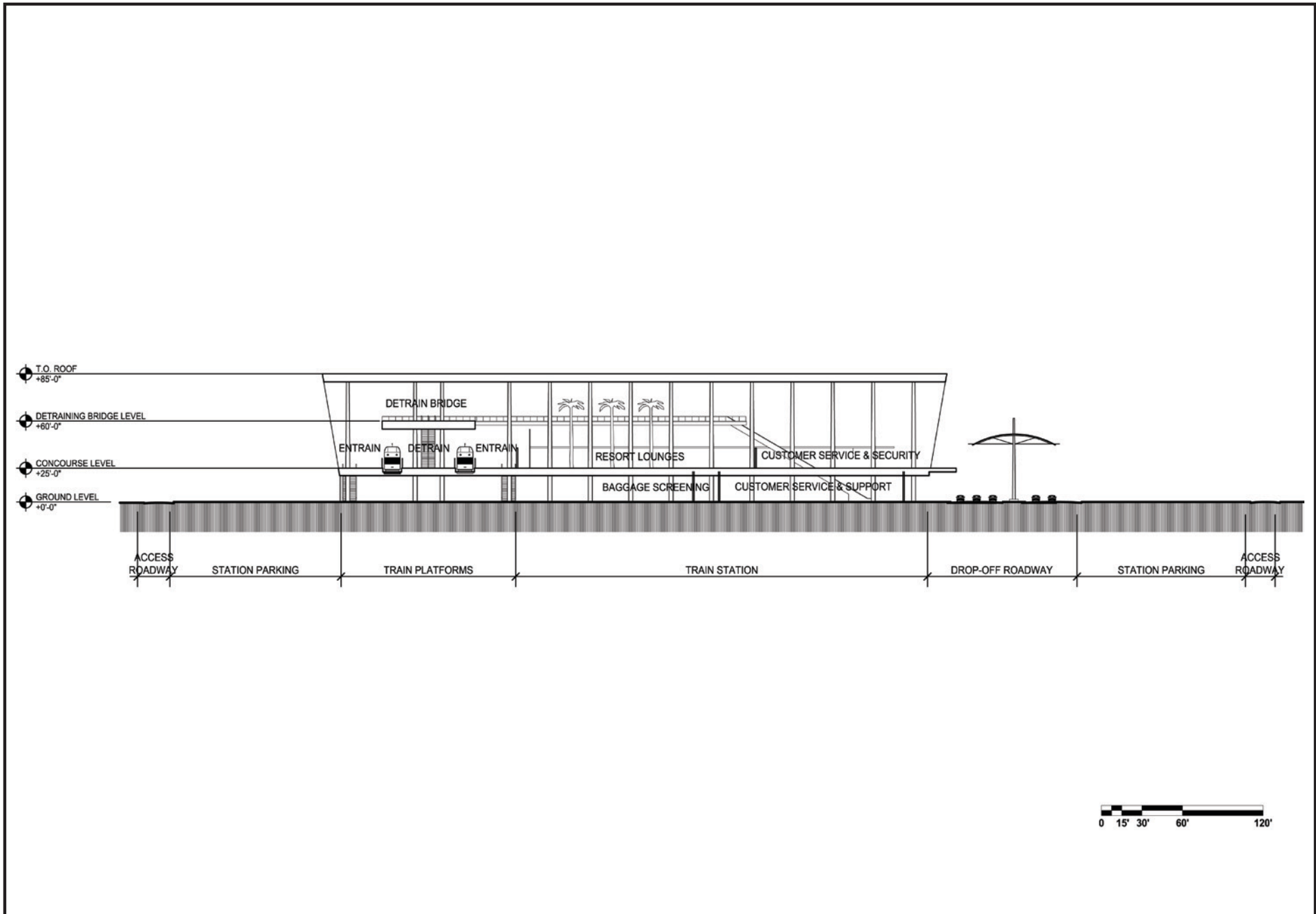

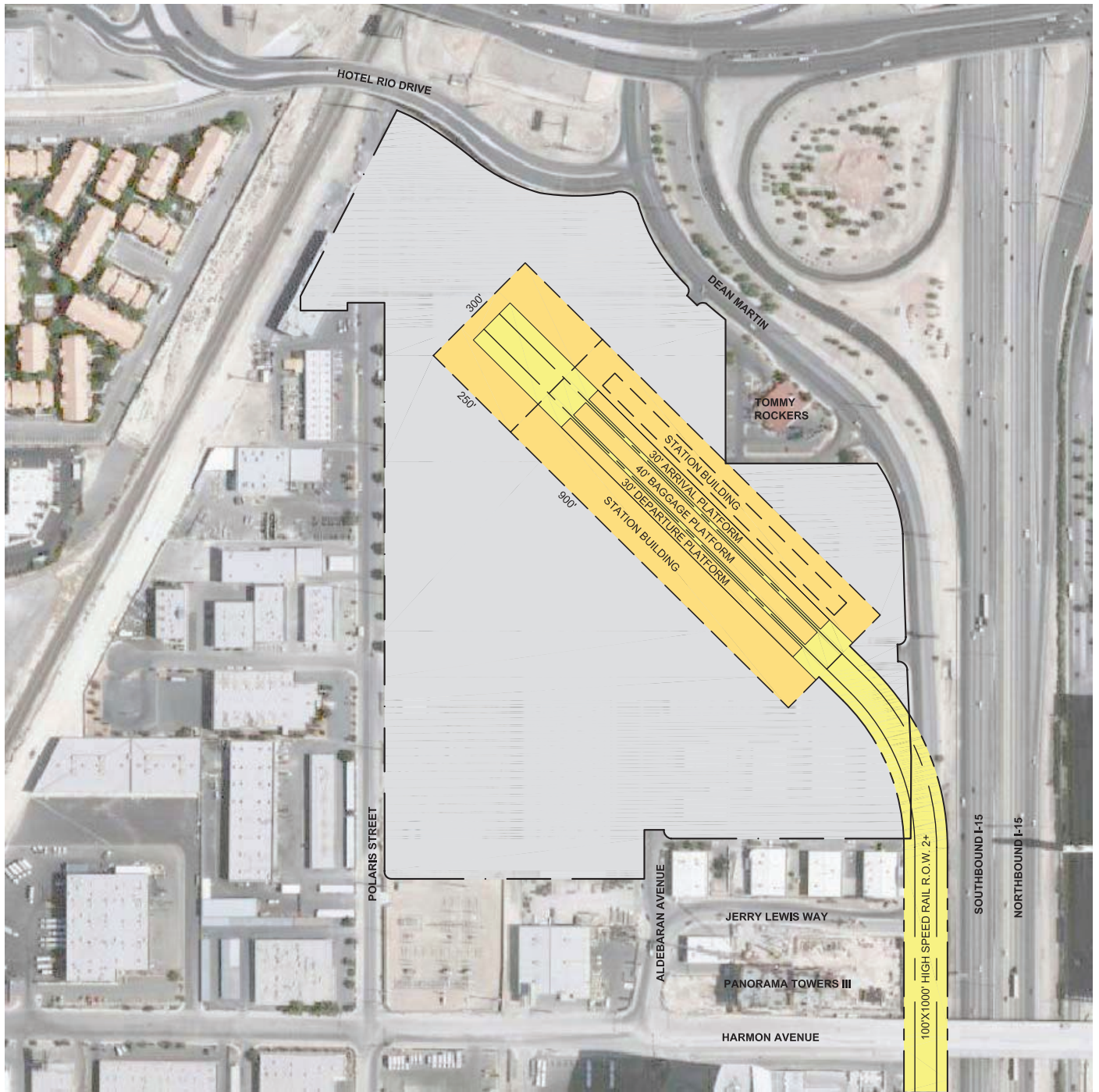

Note: Please refer to Appendix A, which includes plan and profile drawings at 1":1000', seven fold-out maps depicting the DesertXpress project in full, and detailed site plans for all ancillary facilities.

NOT TO SCALE



U.S. Department
of Transportation
**Federal Railroad
Administration**

**DesertXpress
Project EIS**

Central Station Option B, Plan View

FIG

2-20

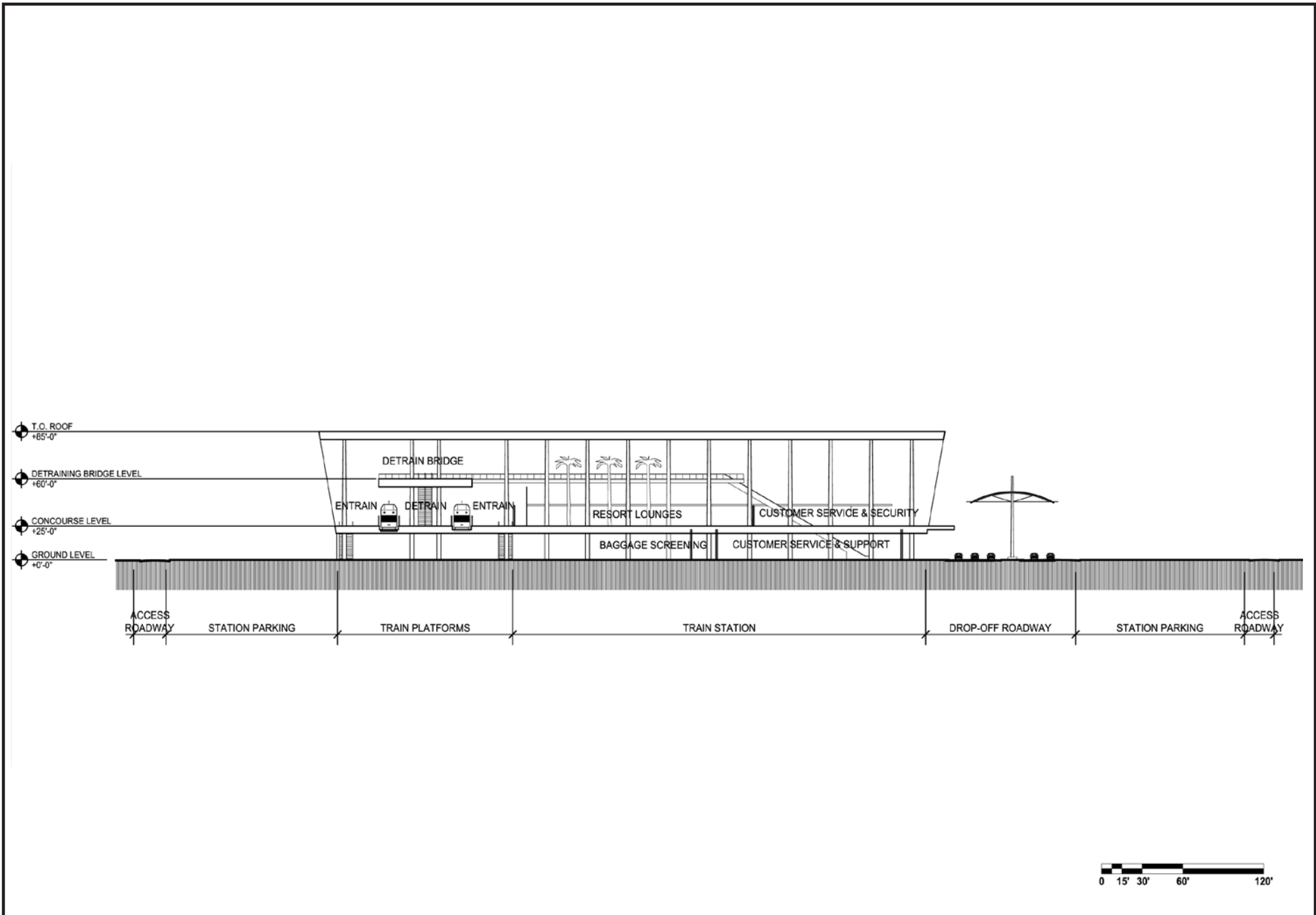

Source: Marnell Architecture, 2008.

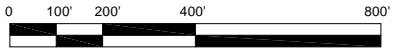

Note: Please refer to Appendix A, which includes plan and profile drawings at 1":1000', seven fold-out maps depicting the DesertXpress project in full, and detailed site plans for all ancillary facilities.

NOT TO SCALE

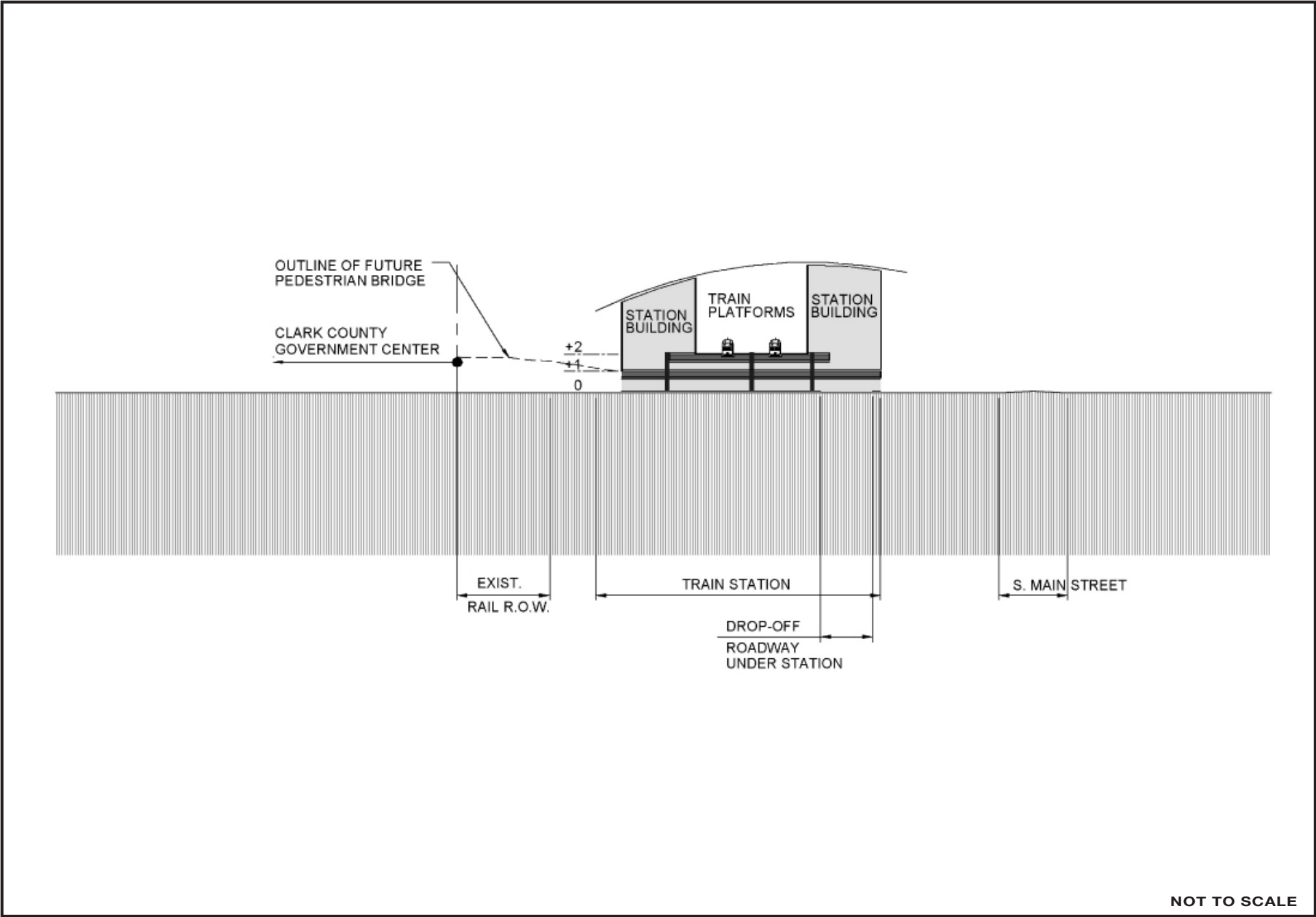

NOT TO SCALE

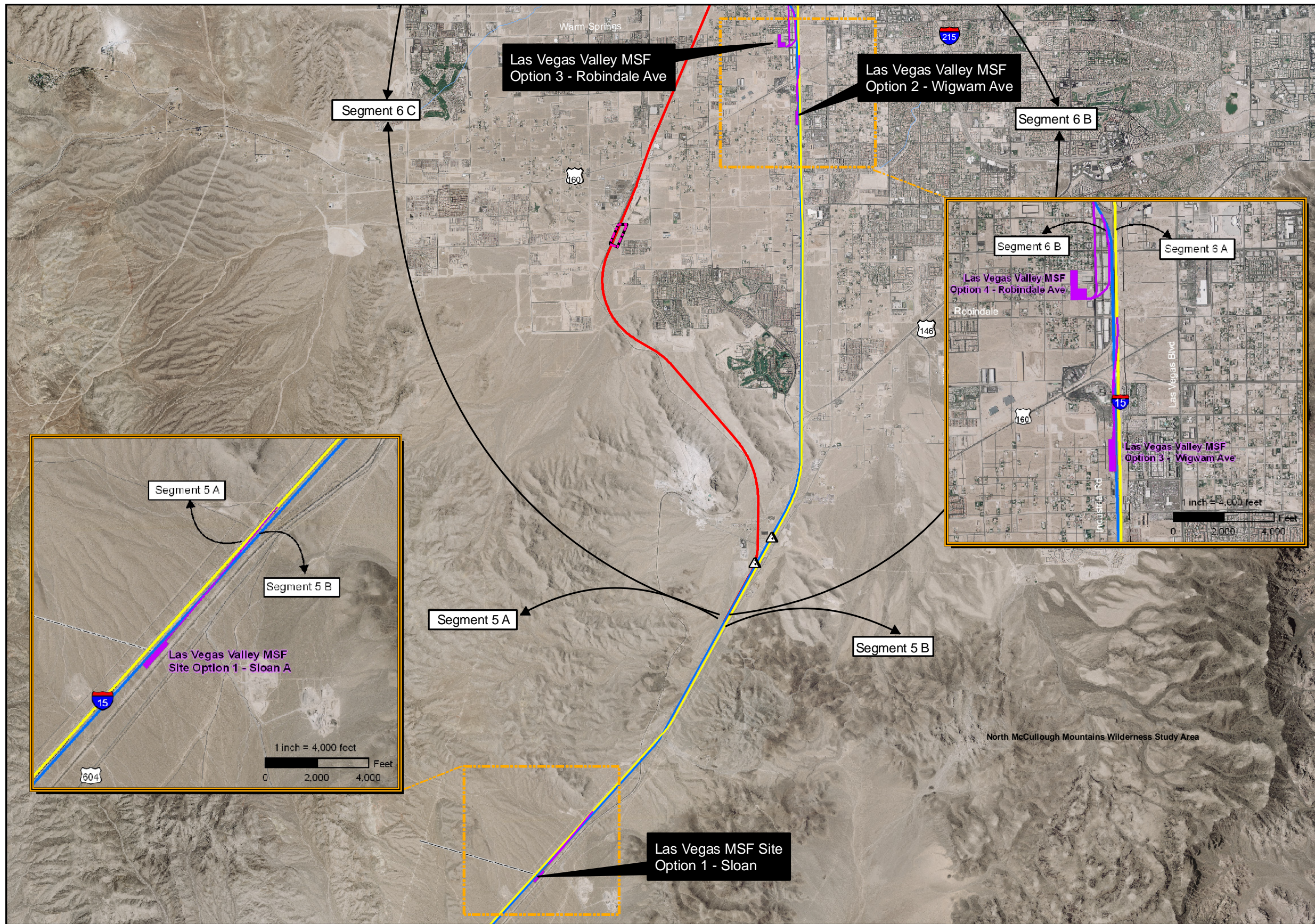

Legend

DesertXpress Alignments

- Alternative A
- Alternative B
- Option C

Ancillary Facility Sites

- Station Options
- Maintenance Facility Options
- Temporary Construction Areas (TCAs)
- Autotransformer (EMU Option Only)
- Electric Utility Corridor (EMU Option Only)

Note: Please refer to Appendix A, which includes plan and profile drawings at 1":1000', seven fold-out maps depicting the DesertXpress project in full, and detailed site plans for all ancillary facilities.

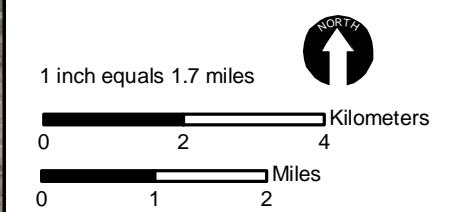

Source: DesertXpress 2007, ESRI 2005, NAIP

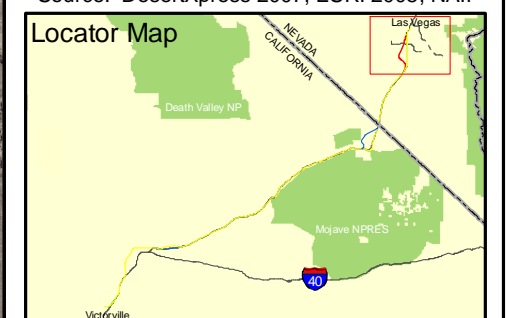



Note: Please refer to Appendix A, which includes plan and profile drawings at 1":1000', seven fold-out maps depicting the DesertXpress project in full, and detailed site plans for all ancillary facilities.





Note: Please refer to Appendix A, which includes plan and profile drawings at 1":1000', seven fold-out maps depicting the DesertXpress project in full, and detailed site plans for all ancillary facilities.

