

STATE OF CALIFORNIA  
REGIONAL WATER QUALITY CONTROL BOARD  
SAN FRANCISCO BAY REGION

STAFF SUMMARY REPORT (Brian K. Wines)  
MEETING DATE: August 13, 2008

ITEM: 5 A

SUBJECT: **Stanford University, Palo Alto, Santa Clara County** – Issuance of Waste Discharge Requirements for the Culverting of a Seasonal Channel between Olmstead Road and Stanford Avenue

CHRONOLOGY: The Board has not considered this item before.

DISCUSSION: This item would issue Waste Discharge Requirements (WDRs) to Stanford University to place fill in a seasonal channel on the Stanford Campus in order to construct an in-fill campus residential development (hereinafter Project) that would provide faculty housing. The Project will require the placement of fill into 2,220 linear feet of a seasonal drainage channel, with a surface area of approximate 0.4 acres, located in the Matadero Creek watershed. The lost stormwater conveyance will be replaced with a culvert under Olmsted Road.

To avoid impacts to relatively undeveloped lands under Stanford's ownership, Stanford is constructing an in-fill project within a developed area of its campus. Because of the long and narrow shape of the parcel, it is not possible to avoid filling the channel and still retain sufficient area to accommodate the development. Therefore, avoidance of the proposed fill is infeasible.

The U.S. Army Corps of Engineers has determined that this channel is not a water of the United States, but, as a water of the State, it remains subject to the Board's Water Code jurisdiction.

To mitigate for the Project's impacts to waters of the State, Stanford will provide mitigation activities within the Matadero Creek watershed. In order to compensate for the lost natural stormwater treatment capacity provided by the channel, Stanford will construct a bioretention swale on the Stanford Campus to treat stormwater runoff. To compensate for the loss of seasonal channel habitat, Stanford will improve existing wildlife habitat along Matadero Creek in an open space area owned by Stanford. Improvements will include livestock exclusion fencing and removal of two noxious non-native plant species. Three live oak trees will also be planted to compensate for the loss of a native oak at the Project site.

Staff has not received any written comments on the Tentative Order (Appendix A), and we expect it to remain uncontested.

RECOMMEN-  
DATION: Adoption of the Tentative Order

APPENDIX: A - Tentative Order

FILE Nos. 2198.09 (BKW); Site No. 02-43-C0579

**APPENDIX A**  
**Tentative Order**

CALIFORNIA REGIONAL WATER QUALITY CONTROL BOARD  
SAN FRANCISCO BAY REGION

TENTATIVE ORDER

WASTE DISCHARGE REQUIREMENTS FOR:

STANFORD UNIVERSITY  
CULVERTING OF A SEASONAL CHANNEL BETWEEN OLMSTED ROAD AND  
STANFORD AVENUE, PALO ALTO, SANTA CLARA COUNTY

The California Regional Water Quality Control Board, San Francisco Bay Region, hereinafter Water Board, finds that:

1. Stanford University (hereinafter Discharger) proposes to construct an in-fill campus residential development project to provide housing for campus faculty, on an undeveloped site on the Stanford University Campus (Project). The Project will include the construction of 39 units of housing on a site on the Stanford Campus, located south of Olmsted Road, west of El Camino Real, north of Stanford Avenue, and east of Escondido Road, in the City of Palo Alto, in Santa Clara County.
2. The Project will require the placement of about 2,235 cubic yards of clean, earthen fill into 2,220 linear feet of a seasonal drainage channel, with a surface area of 17,760 square feet (0.408 acres). An additional 210 linear feet of the channel, adjacent to El Camino Real, will be retained, but will no longer be connected to any upstream channel. The channel runs from west to east through the center of the Project site. The stormwater conveyance lost at the Project site will be replaced with a six-foot diameter buried culvert, placed under Olmsted Road.
3. Stanford's General Use Permit from Santa Clara County calls for faculty housing on the site. In keeping with the General Use Permit, Stanford University is avoiding impacts to higher habitat value, relatively undeveloped lands under Stanford's ownership by providing an in-fill development within already developed areas of the campus. The Project site was selected because it is completely surrounded by existing development. Stanford proposes to construct thirty-nine single-family detached faculty homes on the narrow 6.7-acre parcel, while also providing a public jogging trail and sidewalks along Stanford Avenue and Olmsted Road. Because of the long and narrow shape of the parcel, it is not possible to avoid filling the channel and still retain sufficient surface area to accommodate the housing development, public trail, and sidewalks. Therefore, avoidance of the proposed fill is infeasible for Project construction.
4. An evaluation of the channel (*Location of Areas Potentially Subject to U.S. Army Corps of Engineers Jurisdiction, Wetland/U.S. Waters Delineation for the Stanford Avenue Ditch, Santa Clara County, California*, prepared by Olberding Environmental, October 25, 2001) determined that the bottom of the channel exhibited the following primary and

secondary characteristics of wetlands: vegetation in the bottom of the channel is dominated by vegetation associated with wetland plant communities; the channel bottom contains soils associated with saturated or hydric conditions, including oxidized rhizospheres in the upper 12 inches of the soil profile; and hydrological indicators, in the form of flowing and/or ponded water and sediment deposition, were present.

5. In a letter dated December 3, 2001, the U.S. Army Corps of Engineers (Corps) stated that this channel not subject to federal jurisdiction as a water of the United States under the federal Clean Water Act, pursuant to Corps regulations at 33 Code of Federal Regulations (CFR) 328.3 (Corps File No. 26465S). The channel is subject to the jurisdiction of the Water Board, pursuant to the State's Porter-Cologne Water Quality Act (California Water Code § 13000 et seq.), and is also subject to the jurisdiction of the California Department of Fish and Game (CDFG), pursuant to the State of California's Fish and Game Code.
6. **Mitigation:** To mitigate for the permanent loss of 0.93 cubic feet per second (cfs) of stormwater treatment through vegetative filtration in the bottom of the channel and for the fill of 2,220-linear feet of seasonal channel adjacent to Stanford Avenue, the Discharger shall provide the following mitigation activities within the Matadero Creek watershed:
  - (A) Construct a bioretention swale for stormwater treatment at Roth Way and Lomita Drive on the Stanford Campus, as shown in Attachment A to this Order, to treat 0.93 cfs of untreated stormwater runoff originating from the Stanford campus. Construction will occur in the summer of 2008; and
  - (B) Improve existing wildlife habitat and water quality along 3,420 linear feet of Matadero Creek. Habitat improvements will be made at a 1,950-linear foot section and a 1,470-linear foot section of Matadero Creek, located on the reach of Matadero Creek that runs parallel to Old Page Mill Road, in an open space area that is owned by the Discharger (See figure in Attachment B to this Order). Improvements will include providing livestock exclusion fencing that is designed to exclude horses and cows from the creek channel, but allow deer and other wildlife to pass. The riparian corridor will also be improved by removing two noxious non-native plant species, periwinkle (*Vinca minor*) and scotch broom (*Genista monspessulana*), from the same 3,420 linear feet of Matadero Creek. Non-native species removal will occur annually for three years until the 85 percent removal goal for each species, as specified in Section 4 of the *Mitigation and Monitoring Plan for the Olmsted Road Utilities Relocation Plan impacting the Stanford Avenue Ditch* (MMP), is attained (See Attachment B to this Order). Monitoring for invasive plant species in the treatment area will occur for five years. In addition to invasive species removal, three live oak trees will be planted along the riparian corridor to compensate for the loss of a native oak tree at the Project site.

The proposed mitigation activities are acceptable to the Water Board, with the required submittals listed in the Provisions.

7. On April 10, 2008, the Discharger submitted an application for Waste Discharge Requirements for the Project.
8. The Water Board has determined to regulate the proposed discharge of fill materials into waters of the State by issuance of Waste Discharge Requirements (WDRs) pursuant to Section 13263 of the California Water Code (CWC). The Water Board considers WDRs necessary to adequately address impacts and mitigation to beneficial uses of waters of the State from this Project, to meet the objectives of the California Wetlands Conservation Policy (Executive Order W-59-93), and to accommodate and require appropriate changes over the life of the Project and its construction.
9. The *Water Quality Control Plan for the San Francisco Bay Basin* (Basin Plan) is the Water Board's master water quality control planning document. It designates beneficial uses and water quality objectives for waters of the State, including surface waters and groundwater. It also includes programs of implementation to achieve water quality objectives. The Basin Plan was duly adopted by the Water Board and approved by the State Water Resources Control Board, U.S. EPA, and the Office of Administrative Law where required. The latest version is December 22, 2006. This Order is in compliance with the Basin Plan.
10. The Basin Plan Wetland Fill Policy (policy) establishes that there is to be no net loss of wetland acreage and no net loss of wetland value when the project and any proposed mitigation are evaluated together, and that mitigation for wetland fill projects is to be located in the same area of the Region, whenever possible, as the project. The policy further establishes that wetland disturbance should be avoided whenever possible, and if not possible, should be minimized, and only after avoidance and minimization of impacts should mitigation for lost wetlands be considered.
11. The goals of the California Wetlands Conservation Policy (Executive Order W-59-93, signed August 23, 1993) include ensuring “no overall loss” and achieving a “...long-term net gain in the quantity, quality, and permanence of wetland acreage and values...” Senate Concurrent Resolution No. 28 states that “[i]t is the intent of the legislature to preserve, protect, restore, and enhance California’s wetlands and the multiple resources which depend on them for benefit of the people of the State.” Section 13142.5 of the CWC requires that the “[h]ighest priority shall be given to improving or eliminating discharges that adversely affect...wetlands, estuaries, and other biologically sensitive areas.”
12. The Discharger has demonstrated that avoiding impacts to 0.408 acres of wetlands/waters of the State is not feasible, due to the site constraints described in Finding 3.
13. This Order applies to the permanent fill of waters of the State associated with the Project, which is comprised of the components listed in Finding 2. Construction of the Project will result in the permanent placement of fill in 0.408 acres of jurisdictional waters, extending along 2,200 linear feet of channel. The permanent impact of this fill on waters was identified as a less-than-significant impact with mitigation in the CEQA documents

certified for the Project (*Stanford University Community Plan and General Use Permit Application, Final Environmental Impact Report*, December 18, 2000, State Clearinghouse Number 1999112107, Notice of Determination filed with the Santa Clara County Clerk on December 13, 2000, and the *Stanford Avenue Ditch Relocation CEQA Addendum*, June 12, 2008).

14. Discharges of stormwater associated with construction activity will occur. The CEQA documents certified for the Project identify such discharges, including the pollutants associated with them, as a potentially significant impact. The Discharger is responsible for obtaining appropriate permits for these discharges, including complying with the rules and regulations of National Pollutant Discharge Elimination System (NPDES) permit requirements. This includes complying with the requirements of State Water Resources Control Board Water Quality Order No. 99-08-DWQ, the NPDES General Permit for Storm Water Discharges Associated with Construction Activity (hereinafter General Permit).
15. Discharges of storm water associated with the post-construction operation and maintenance of the new faculty housing at the Project site will occur following its completion. The Discharger is responsible for complying with Provision C.3 of the Santa Clara Valley Urban Runoff Pollution Prevention Program's NPDES Permit (NPDES No. CAS029718, Regional Board Order No. 01-024; NPDES Permit, CAS0299718, as amended by Order Nos. 01-119 and R2-2005-0035), the NPDES Municipal Storm Water Permit that covers Santa Clara County. Stormwater treatment at the new housing shall be consistent with Drawing Numbers 1 and 2 of the *Stormwater Treatment Concept, Stanford Housing, Palo Alto, Santa Clara County, California* (BKF Engineers, Job No. 20065138-52, 07/30/07) and the Technical Memorandum, *Stanford Avenue Faculty Housing Proposed Stormwater Treatment*, (BKF Engineers, BKF No. 20076072-10, March 28, 2008) (See Attachment C to this Order).
16. Discharges of ground water or other non-storm water during construction may be required. This Order considers such discharges covered by the General Permit, contingent on submittal of an acceptable discharge plan at least 30 days prior to such a discharge.
17. The California Environmental Quality Act (CEQA) requires all projects approved by State agencies to be in full compliance with CEQA, and requires a lead agency to prepare an appropriate environmental document for such projects. The Water Board, as a responsible agency under CEQA, finds that all environmental effects have been identified for Project activities which it is required to approve, and that those proposed Project activities, with the implementation of the mitigation identified in Finding 6, above, in accordance with the implementation deadlines in Provisions B4 and B5, below, will not have significant adverse impacts on the environment. The lead agency's CEQA Findings are presented in the Project's environmental documents (*Stanford University Community Plan and General Use Permit Application, Final Environmental Impact Report*, December 18, 2000, State Clearinghouse Number 1999112107, and the *Stanford Avenue*

*Ditch Relocation CEQA Addendum*, June 12, 2008).

18. The Water Board has notified the U.S. Army Corps of Engineers (Corps), California Department of Fish and Game (CDFG), the City of Palo Alto, Santa Clara County, and other interested agencies and persons of its intent to prescribe WDRs for this discharge.
19. The Water Board, in a public meeting, heard and considered all comments pertaining to the discharge.
20. This Project file is maintained at the Water Board under Site No. 02-43-C0579.

IT IS HEREBY ORDERED that the Discharger, in order to meet the provisions contained in Division 7 of the California Water Code and regulations adopted thereunder, shall comply with the following, pursuant to authority under CWC Sections 13263 and 13267:

**A. Discharge Prohibitions**

1. The direct discharge of wastes, including rubbish, refuse, bark, sawdust, or other solid wastes into surface waters or at any place where they would contact or where they would be eventually transported to surface waters, including flood plains, is prohibited.
2. The discharge of floating oil or other floating materials from any activity in quantities sufficient to cause deleterious bottom deposits, turbidity, or discoloration in surface waters is prohibited.
3. The discharge of silt, sand, clay, or other earthen materials from any activity in quantities sufficient to cause deleterious bottom deposits, turbidity, or discoloration in surface waters is prohibited.
4. The wetland fill activities subject to these requirements shall not cause a nuisance as defined in CWC §13050(m).
5. The groundwater in the vicinity of the Project shall not be degraded as a result of the Project activities or placement of fill for the Project.
6. The discharge of materials other than storm water, which are not otherwise regulated by a separate NPDES permit or allowed by this Order, to waters of the State is prohibited.

**B. Provisions**

1. The Discharger shall comply with all Prohibitions and Provisions of this Order immediately upon adoption of this Order or as provided below.
2. The Discharger shall submit copies of all necessary approvals and/or permits for the Project and mitigation projects from applicable government agencies, including, but not

limited to, CDFG and Santa Clara County, for each Project component as applicable to that component, prior to the start of construction on that component.

Project Implementation Deadlines

3. The Discharger shall conduct fill activities in the channel at the Project site between June 30 and November 30.
4. The Discharger shall construct the Roth Way - Lomita Drive stormwater treatment bioswale (See Attachment A) within 180 days of adoption of this Order.
5. The Discharger shall begin implementation of approved mitigation activities at Matadero Creek, as described in the MMP (See Attachment B), within 270 days of adoption of this Order.
6. Not later than 30 days prior to the beginning of construction of any project component, the Discharger shall submit, acceptable to the Executive Officer, a SWPPP to address the Project's expected construction stage impacts.
7. Not later than 360 days after adoption of this Order the Discharger shall submit, acceptable to the Executive Officer, final plans for post-construction stormwater treatment measures at the Project site (See Attachment C) to address the Project's impacts on the quality of stormwater runoff.

Notice of Mitigation Implementation

8. The Discharger shall provide the Water Board with as-built plans of the Roth Way - Lomita Drive stormwater treatment bioswale within 360 days of adoption of this order.
9. The Discharger shall provide the Water Board with documentation of the installation of live-stock exclusion fencing along Matadero Creek, as described in the MMP, within 360 days of adoption of this order.
10. The Discharger shall provide the Water Board with annual reports on the invasive species eradication program along Matadero Creek, as specified in the MPP, no later than December 31 of each year in which invasive species are actively eradicated or the sites are monitored for the presence of invasive species. Annual reports shall also describe the condition of the livestock exclusion fencing, including documentation of any maintenance activities performed in the prior year and any recommendations for maintenance of the fencing.

Other Provisions

11. The Discharger is responsible for maintaining the Roth Way – Lomita Drive stormwater treatment bioswale and for the implementation of the MMP.



12. No equipment shall be operated in areas of flowing or standing water; no fueling, cleaning, or maintenance of vehicles or equipment shall take place within any areas where an accidental discharge to waters of the State may occur.
13. The Discharger shall immediately notify the Water Board by telephone whenever an adverse condition occurs as a result of this Project. Such a condition includes, but is not limited to, a violation of the conditions of this Order, a significant spill of petroleum products or toxic chemicals, or damage to control facilities that would cause noncompliance. Pursuant to CWC §13267(b), a written notification of the adverse condition shall be submitted to the Water Board within two weeks of occurrence. The written notification shall identify the adverse condition, describe the actions necessary to remedy the condition, and specify a timetable, subject to the modifications of the Water Board, for the remedial actions.
14. Should discharges of otherwise uncontaminated ground water contaminated with suspended sediment or other non-storm water that has accumulated in utility trenches or other portions of the Project be required, where such discharges are not otherwise covered by an applicable NPDES permit, such discharges may be considered covered by the General Permit, following the Discharger's submittal of a discharge/treatment plan, acceptable to the Executive Officer, at least 30 days prior to such a discharge.
15. The Discharger shall notify the Water Board in writing at least 30 days prior to actual start dates for each Project component (i.e., prior to the start of grading or other construction activity for any Project component).
16. The Discharger is considered to have full responsibility for correcting any and all problems that arise in the event of a failure that results in an unauthorized release of waste or wastewater.
17. The discharge of any hazardous, designated or non-hazardous waste as defined in Title 23, Division 3, Chapter 15 of the California Administrative Code, shall be disposed of in accordance with applicable state and federal regulations.
18. The Discharger shall remove and relocate any wastes that are discharged at any sites in violation of this Order.
19. In accordance with CWC §13260, the Discharger shall file with the Water Board a report of any material change or proposed change in the ownership, character, location, or quantity of this waste discharge. Any proposed material change in operation shall be reported to the Executive Officer at least 30 days in advance of the proposed implementation of any change. This shall include, but not be limited to, all significant new soil disturbances, all proposed expansions of development, or any change in drainage characteristics at the Project site. For the purpose of this Order, this includes any proposed change in the boundaries of the area of wetland/waters of the State to be filled.

20. The Discharger shall maintain a copy of this Order at the Project site so as to be available at all times to site operating personnel and agencies.
21. The Discharger shall permit the Water Board or its authorized representative at all times, upon presentation of credentials:
  - a. Entry onto Project premises, including all areas on which wetland fill or wetland mitigation is located or in which records are kept.
  - b. Access to copy any records required to be kept under the terms and conditions of this Order.
  - c. Inspection of any treatment equipment, monitoring equipment, or monitoring method required by this Order.
  - d. Sampling of any discharge or surface water covered by this Order.
22. This Order does not authorize commission of any act causing injury to the property of another or of the public; does not convey any property rights; does not remove liability under federal, state, or local laws, regulations or rules of other programs and agencies; nor does this Order authorize the discharge of wastes without appropriate permits from other agencies or organizations.
23. The Water Board will consider rescission of this Order upon Project completion and the Executive Officer's acceptance of notices of completion of mitigation for all mitigation, creation, and enhancement projects required or otherwise permitted now or subsequently under this Order.

I, Bruce H. Wolfe, Executive Officer, do hereby certify that the foregoing is a full, complete, and correct copy of an Order adopted by the California Regional Water Quality Control Board, San Francisco Bay Region, on \_\_\_\_\_, 2008.

---

Bruce H. Wolfe  
Executive Officer

- Attachment A: Roth Way – Lomita Drive Stormwater Treatment Swale  
Attachment B: Mitigation and Monitoring Plan for the Olmstead Road Utilities Relocation Plan  
Attachment C: Conceptual Post-Construction Stormwater Treatment at the Stanford Avenue Residential Development.

# **ATTACHMENT A**

*Roth Way – Lomita Drive  
Stormwater Treatment Swale*

---

## Worksheet for Design Condition - Roth/Lomita Biofiltration Swale -

---

### Project Description

Friction Method	Manning Formula
Solve For	Normal Depth

### Input Data

Roughness Coefficient	0.050	
Channel Slope	0.00300	ft/ft
Left Side Slope	4.00	ft/ft (H:V)
Right Side Slope	4.00	ft/ft (H:V)
Bottom Width	6.00	ft
Discharge	3.28	ft <sup>3</sup> /s

### Results

Normal Depth	0.48	ft
Flow Area	3.82	ft <sup>2</sup>
Wetted Perimeter	9.97	ft
Top Width	9.86	ft
Critical Depth	0.20	ft
Critical Slope	0.06514	ft/ft
Velocity	0.86	ft/s
Velocity Head	0.01	ft
Specific Energy	0.49	ft
Froude Number	0.24	
Flow Type	Subcritical	

### GVF Input Data

Downstream Depth	0.00	ft
Length	0.00	ft
Number Of Steps	0	

### GVF Output Data

Upstream Depth	0.00	ft
Profile Description		
Profile Headloss	0.00	ft
Downstream Velocity	Infinity	ft/s
Upstream Velocity	Infinity	ft/s
Normal Depth	0.48	ft
Critical Depth	0.20	ft
Channel Slope	0.00300	ft/ft
Critical Slope	0.06514	ft/ft

---

## Worksheet for Design Condition - Roth/Lomita Biofiltration Swale -

---

### Messages

#### Notes

The flow was obtained from the Campus wide Stormwater Treatment Master Plan, dated May 18, 2005. This flow included Areas 4, 5 and 7 (Ditch D2 and Ditch D4 in the report) cited in the document.

Based upon the flow velocity within the swale, the treatment time is approximately 5 minutes.

REFS: SIB2241-45, EXT-45, EXIT-45, PROP-45, PROP200-45, extnew1

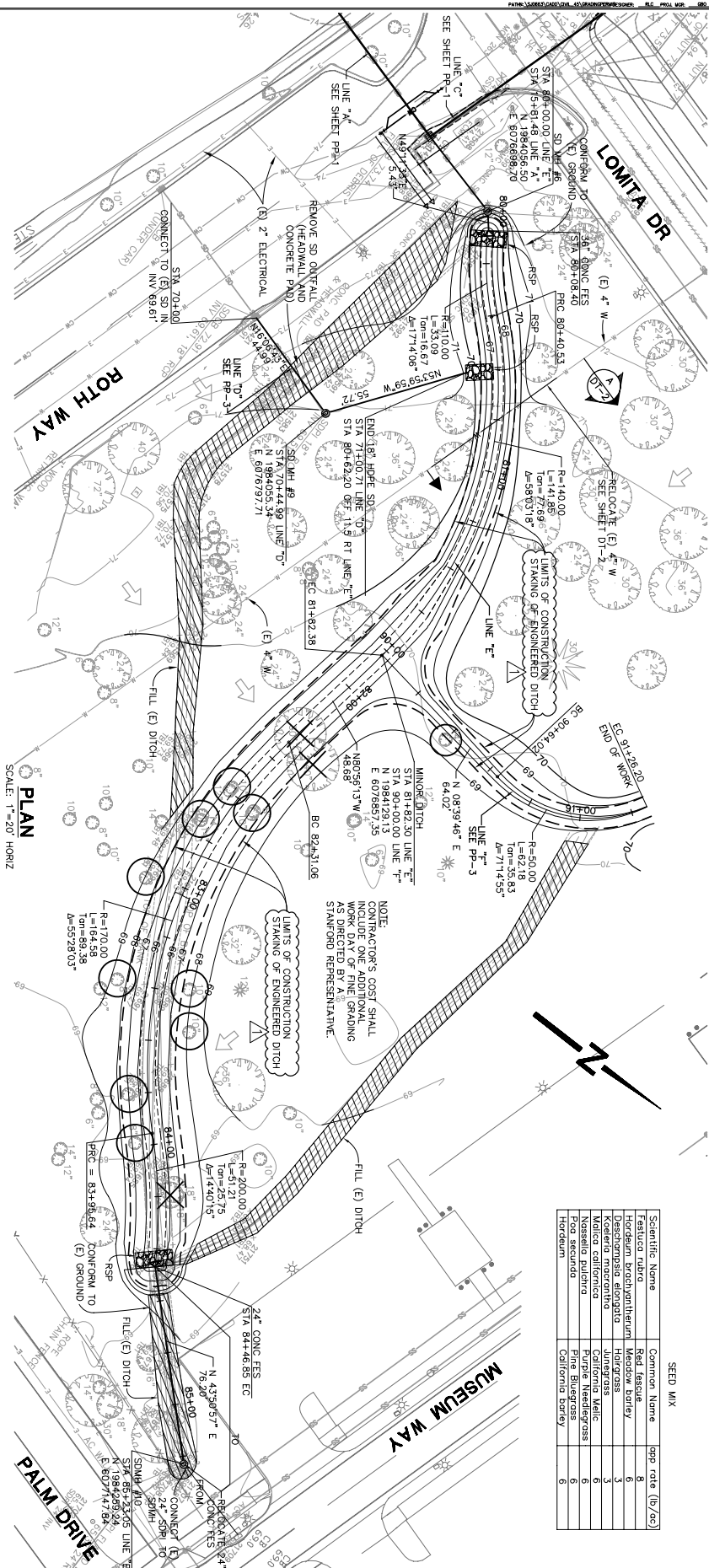
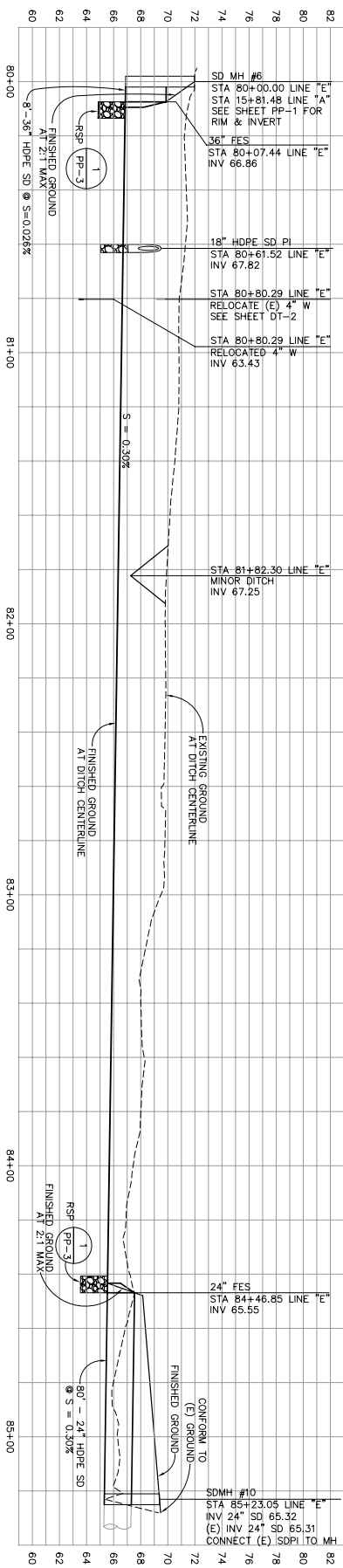

APPLICANT: STANFORD UNIVERSITY ROAD NAME: ROTH WAY/LOMITA DRIVE COUNTY FILE NO.: 7186-7-81-07G

PROFILE SCALE: 1" = 4' VERT 1" = 20' HORIZ

PLAN SCALE: 1" = 20' HORIZ

SEED MIX

Scientific Name	Common Name	ppp rate (lb/ac)
Festuca rubra	Red fescue	6
Hordeum brachyantherum	Meadow barley	6
Deschampsia elongata	Horgrass	3
Koeleria macrantha	Horgrass	3
Medicago sativa	Alfalfa	6
Poa annua	Annual meadowgrass	6
Poa secunda	Poa secunda	6
Hordeum	Hordeum	6

NO.	BY	DATE	REVISION
1	SEM	2/21/07	REVISED CONTOURS

The engineer preparing these plans will not be responsible for, or liable for, unauthorized changes to or use of these plans. All changes to the plans must be in writing and must be approved by the preparer of these plans.

REGISTERED PROFESSIONAL ENGINEER  
 CIVIL  
 No. 12345  
 State of California  
 PP-2  
 SHEET NUMBER  
 3 OF 7 SHEETS  
 DATE: 12/13/07  
 2007 WINTER  
 S:\000000\_0000

**NOLTE**  
 BEYOND ENGINEERING  
 701 NORTH FIRST STREET, SUITE A  
 408.927.200 TEL. 408.926.0191 FAX  
 SAN JOSE, CA. 95112  
 WWW.NOLTE.COM

STANFORD UNIVERSITY  
 ROTH AND LOMITA DRAINAGE IMPROVEMENTS  
 PLAN AND PROFILE  
 DITCH IMPROVEMENTS  
 PREPARED FOR: STANFORD UNIVERSITY DATE SUBMITTED: 12/13/07

FILES: S1R22041-45, PPRF502-45, EXJIT\_45, PPRF503-45, EXTO\_45, PPRF504-45, PPRF505-45, PPRF506-45, PPRF507-45, PPRF\_45, PPRF504-45

**PROFILE - LINE B**  
**NOT USED**

**PROFILE - LINE C**  
SCALE: 1"=20' HORIZ  
1"=4' VERT

**PROFILE - LINE D**  
SCALE: 1"=20' HORIZ  
1"=4' VERT

**PROFILE - LINE F**  
SCALE: 1"=20' HORIZ  
1"=4' VERT

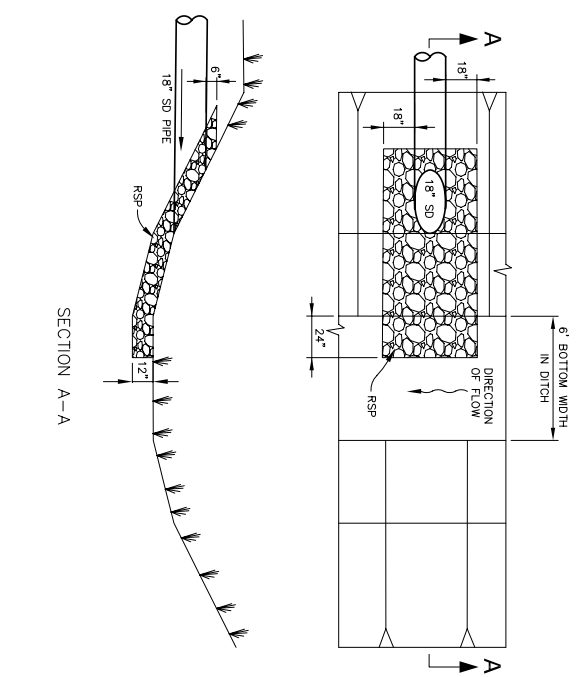
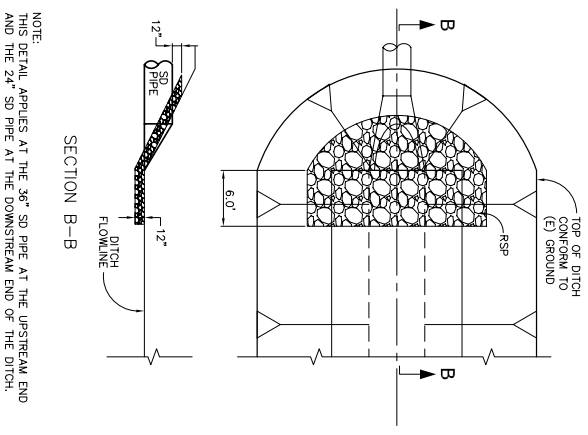
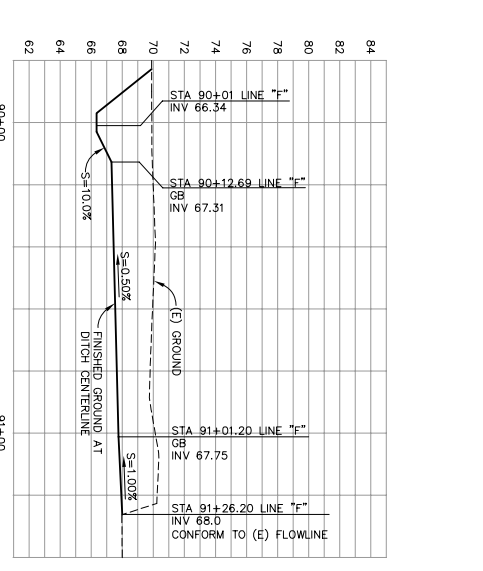
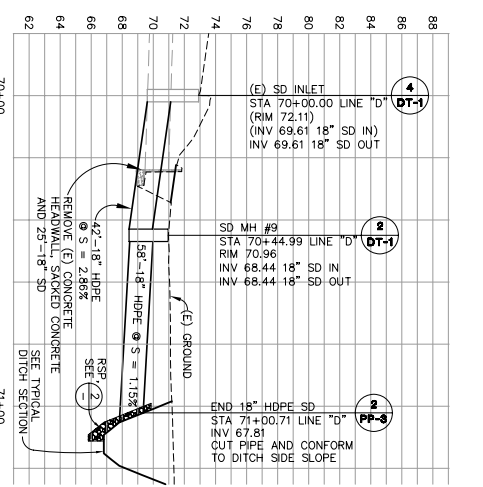
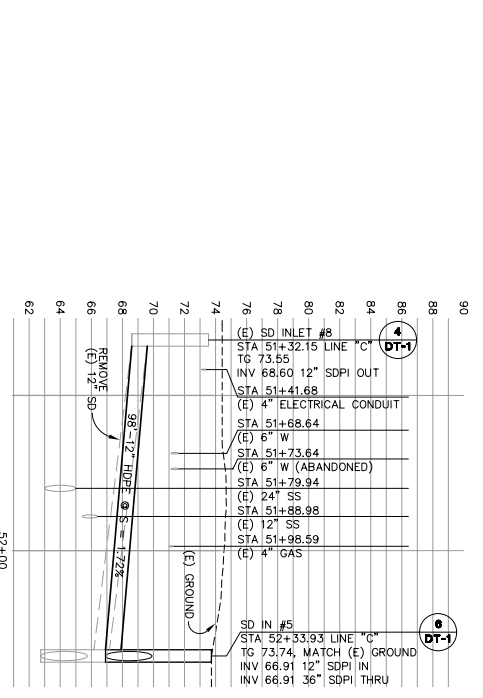

**ROCK SLOPE PROTECTION 1**  
N.T.S.

**ROCK SLOPE PROTECTION AT LINE "D" 2**  
N.T.S.

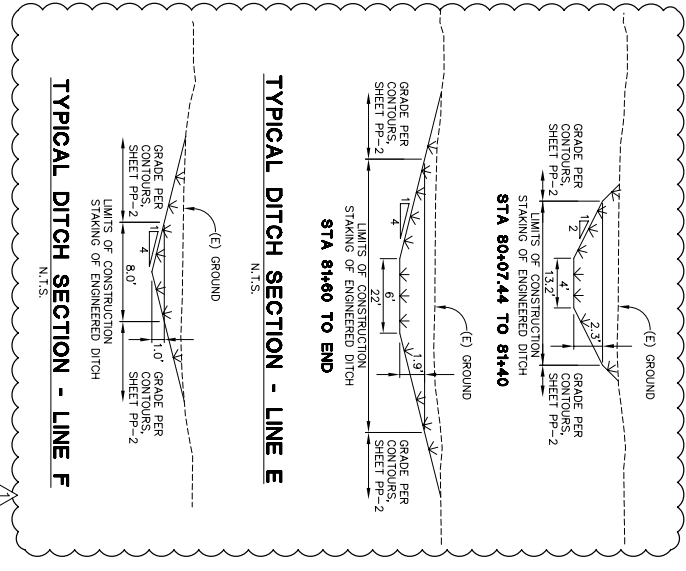

APPLICANT: STANFORD UNIVERSITY ROAD NAME: ROTH WAY/LOMITA DRIVE COUNTY FILE NO.: 71867-81-07G

SHEET NUMBER: PP-3  
SCALE: 1"=20' HORIZ  
1"=4' VERT  
DATE: 8/21/07  
DRAWN BY: [Signature]

**NOLTE**  
BEYOND ENGINEERING  
2701 NORTH FIRST STREET, SUITE A SAN JOSE, CA 95131  
408.932.7200 TEL 408.932.0101 FAX WWW.NOLTE.COM

STANFORD UNIVERSITY  
ROTH AND LOMITA DRAINAGE IMPROVEMENTS  
STORM DRAIN PROFILES AND  
TYPICAL SECTIONS AND DETAILS  
PREPARED FOR: STANFORD UNIVERSITY DATE SUBMITTED: 12/13/06

NO.	BY	DATE	REVISION
1	SEM	2/21/07	DITCH GRADING

The engineer preparing these plans will not be responsible for, or liable for, unauthorized changes to or use of these plans. All changes to the plans must be in writing and must be approved by the preparer of these plans.

# **ATTACHMENT B**

*Mitigation and Monitoring Plan for the Olmsted Road  
Utilities Relocation Plan impacting the Stanford Avenue Ditch  
May 2008*



# **MITIGATION AND MONITORING PLAN**

**FOR THE**

## **OLMSTED ROAD UTILITIES RELOCATION PLAN PROJECT**

**IMPACTING THE**

**STANFORD AVENUE DITCH**

**STANFORD UNIVERSITY**

**SANTA CLARA COUNTY, CALIFORNIA**

Prepared for:

**STANFORD UNIVERSITY**

Stanford Real Estate  
2755 Sand Hill Road, Suite 100  
Menlo Park, California 94025

Phone: (650) 926-0284 - Fax: (650) 854-9268  
Contact: Steve Elliott, Managing Director

Prepared by:

**OLBERDING ENVIRONMENTAL, INC.**

Wetland Regulatory Consultants  
1390 Willow Pass Road, Suite 370  
Concord, California 94520

Phone: (925) 825-2111 – Fax: (925) 825-2112  
Contact: Jeff Olberding

**MAY 2008**

---

---

## TABLE OF CONTENTS

---

<b>SUMMARY</b> .....	1
<b>1.1 Location of Project and Mitigation Sites</b> .....	2
<b>1.2 Jurisdictional Area Summary</b> .....	2
<b>1.3 Brief Summary of Overall Project</b> .....	2
<b>1.4 Responsible Parties</b> .....	4
<b>1.5 Habitat Types and Functions of the Jurisdictional Areas Impacted</b> ...	4
<b>2.0 GOALS OF THE MITIGATION PLAN</b> .....	5
<b>3.0 MONITORING PLAN</b> .....	7
<b>3.1 Annual Report</b> .....	7
<b>4.0 LIVESTOCK EXCLUSION FENCES</b> .....	8
<b>4.1 Fence Maintenance Plan</b> .....	8
<b>4.2 Responsible Party</b> .....	9

---

---

## ATTACHMENTS

---

### ATTACHMENT 1 FIGURES

Figure 1	Regional Map
Figure 2	Vicinity Map
Figure 3	USGS Quadrangle Map
Figure 4	Aerial Map
Figure 5	Mitigation Map
Figure 6	Roth-Lomita Drainage
Figure 7	Matadero Creek Habitat Improvement Area

### ATTACHMENT 2 DITCH EXHIBIT

### ATTACHMENT 3 SITE PHOTOS

---

This report should be cited as: Olberding Environmental, Inc. May 2008. *Mitigation and Monitoring Plan for the Olmsted Road Utilities Relocation Plan*, Santa Clara County California. Prepared for Stanford University, Stanford, California.

## **SUMMARY**

This document is intended to provide the information necessary for agency review of proposed riparian enhancement activities proposed to compensate for impacts associated with the Olmsted Road Utilities Relocation Plan on the Stanford University Campus, impacting the Stanford Avenue ditch, in Santa Clara County, California. The work is proposed in association with a planned faculty housing project proposed on a narrow strip of undeveloped land which is surrounded by existing development.

The Project has been reviewed for potential impacts to wetlands, waters of the United States, waters of the State, and areas regulated by California Department of Fish and Game. While there are no impacts to waters of the United States, the ditch has been determined waters of the State under the Porter Cologne Act, and therefore its fill and relocation requires authorization from the California Department of Fish and Game, and from the Regional Water Quality Control Board. Relocation of the 2,430-foot ditch will result in the fill of 2,220 linear feet of ditch. The remaining 210 feet of ditch near El Camino Real will be retained but will no longer be connected to any upstream channel. The ditch will be replaced with an underground culvert, placed beneath Olmsted Road.

The proposed project will result in the permanent fill of 0.408 acres of the ditch. Additionally, 0.038 acres of the ditch will be isolated from upstream flow and will no longer serve to incidentally filter campus runoff. Mitigation for the loss of 0.93 cubic feet per second (cfs) of filtration capacity will be accomplished through the construction of the Ross-Lomita C-3 swale proposed on the Stanford University campus. This document will describe the proposed mitigation for the loss of 2,220 linear feet or 0.408 acres of marginal wildlife habitat.

Stanford University has proposed to mitigate for habitat loss by improving existing wildlife habitat and water quality along an approximately 1,950-foot section and an approximately 1,470-foot section of Matadero Creek (3,420 feet total) by fencing the creek from livestock, which are known to enter the creek from the adjacent property. Additionally, Stanford University has proposed to improve the riparian corridor by removing noxious non-native plant species (periwinkle and French broom) from both sections of Matadero Creek. Non-native species removal will occur annually for three years until target species composition goals are met; monitoring will occur for five years. Finally, to mitigate for the removal of a native oak within the project site, Stanford will plant three trees in a designated open area within the Matadero Creek corridor.

## **1.0 PROJECT DESCRIPTION FOR WHICH MITIGATION IS REQUIRED**

### **1.1 Location of Project and Mitigation Sites**

The following figures provide the location of the project. Attachment 1, Figure 1 depicts the regional location of the project in Santa Clara County. Attachment 1, Figure 2 illustrates the vicinity of the project in relationship to the Stanford University Campus. Attachment 1, Figure 3 identifies the location of the project on the USGS 7.5 Quadrangle Map for Palo Alto. Figure 4 shows the project on an aerial. Figure 5 identifies the project site in relation to the proposed mitigation sites, while Figure 6 illustrates plans for the proposed Roth-Lomita C-3 Drainage. Figure 7 specifically identifies the location of proposed mitigation along Matadero Creek.

The project area is the long narrow area between Stanford Avenue and Olmsted Road, starting at Escondido Road and ending at El Camino Real. Access to the Project Area is attained from El Camino Real by heading west on Stanford Avenue, turning right on Wellesley Ave. and parking on Olmsted Road.

The proposed mitigation along Matadero Creek is located along Old Page Mill Road between its two intersections with Page Mill Road. The C-3 drainage is proposed on the Stanford Campus near the intersections of Roth Avenue and Lomita Drive.

### **1.2 Jurisdictional Area Summary**

The ditch along Stanford Avenue is a constructed drainage channel that has been graded to convey stormwater runoff from Stanford University and the surrounding residential community. Despite being a man-made ditch created in the uplands and being exempted from the Clean Water Act by the US Army Corps of Engineers, the RWQCB and CDFG have determined that the ditch is a water of the State. As shown in Attachment 3, photos 1 and 2, the ditch consists of a nearly straight channel that averages eight feet wide. The banks of the ditch are graded at a 2:1 to 3:1 slope and the bottom is roughly four feet below the surrounding topography. The channel banks are predominately barren or covered by upland grasses or pine needles from the landscape trees. The channel does not contain any riparian vegetation. The channel bottom currently contains shallow ponded water at several locations. The primary source of hydrology appears to be stormwater and irrigation runoff. There are areas within the channel bottom that contain sparse to moderate amounts of wetland vegetation. The ditch occurs in an open space area approximately 40-80 feet wide between Stanford Avenue and Olmsted Road. Campus buildings, parking lots and landscape make up the surrounding land uses. There are three road crossings (Oberlin Street, Wellesley Street and Yale Street) along the ditch alignment. Each of the crossings consists of a metal or concrete culvert.

### **1.3 Brief Summary of Overall Project**

Stanford's General Use Permit from Santa Clara County calls for faculty housing on the site. Stanford proposed to construct thirty-nine (39) single-family detached faculty

homes on the narrow 6.7-acre parcel. The site plan maximizes the unit yield at 39 units along this linear, narrow parcel, while also providing for a public jogging trail and sidewalk along Stanford Avenue and a public sidewalk along Olmsted Road, connected through pedestrian paseos. The faculty homes will maintain the same 25-foot setback and 30-foot height restriction that occur in the College Terrace neighborhood to the south of Stanford Avenue. The proposed development will provide localized treatment of storm water within the project site area as a means to mitigate the addition of impervious surfaces (new parking courts, house footprints, sidewalks and driveways) that are a part of the new development. The on-site storm water will be treated in vegetated swales and/or bioretention areas located along Stanford Avenue between the new homes and the back of sidewalks.

A seasonal drainage ditch, locally known as the Stanford Avenue ditch, traverses the entire length of the site from Escondido Road to El Camino Real, as is shown in Attachment 2, Ditch Exhibit. Owing to the long and narrow parcel shape, it is not possible to avoid filling the ditch and still retain enough usable space for the housing development. As a result, the entire ditch must be filled and the storm drain that replaces it relocated under Olmsted Road in a pipe of approximately six feet in diameter, sized to accommodate a 100-year storm event. The project also involves relocation of sewer and water utilities to mitigate conflicts. After the storm drain is placed under Olmsted Road, approximately 715 cy of clean earthen fill will be deposited in the ditch below the ordinary high water mark (2,235 cy to the top of bank) to create a level building area for the construction of faculty housing.

The underground pipe proposed to replace the ditch will convey all off-site storm water that currently enters the project site at Escondido Road and the various inlets from Escondido Village along Olmsted Road. Water from the pipe will be discharged to the CalTrans storm water system in El Camino Real. This off-site storm water will not be treated on the project site. The existing drainage ditch has never been considered a treatment facility and only provides a route of passage into the CalTrans system. The proposed project is replacing this above-ground drainage facility with an underground system. As a result any incidental filtration function of the ditch will be permanently lost.

Stanford proposes to initiate the Project in summer when the channel is at its driest with nearly no flow. Because the channel will be dry and urban runoff flows will already be permanently diverted into other stormwater systems, there will be no need to temporarily divert flows. The intention is to complete as much work as possible during the summer break to minimize inconvenience to students and faculty utilizing the Escondido Village housing area on Stanford Campus.

The Project's construction would result in the permanent fill of 0.408 acres of the ditch. (dimensions: 8-feet wide by 2,220-feet long excluding existing culverted crossings) Additionally, 0.038 acres of the ditch (210-feet by 8-feet wide) will be isolated from

upstream flow and will no longer serve to incidentally filter campus runoff. Project grading would also remove one eight-inch-dbh native oak tree (*Quercus spp.*).

#### **1.4 Responsible Parties**

The applicant for this project is:

Stanford University  
Stanford Real Estate  
2755 Sand Hill Road, Suite 100  
Menlo Park, California 94025  
Telephone: (650) 926-0284  
Fax: (650) 854-9268  
Contact: Steve Elliott, Managing Director

This mitigation plan is being prepared by:

Olberding Environmental, Inc.  
Wetlands Regulatory Consultants  
1390 Willow Pass Road, Suite 370  
Concord, California 94520  
Telephone: (925) 825-2111  
Fax: (925) 825-2112  
Contact: Mr. Jeff Olberding

#### **1.5 Habitat Types and Functions of the Jurisdictional Areas Impacted**

##### ***Annual Grassland***

The majority of the project site is considered annual grassland with planted native and non-native trees, which is not considered a jurisdictional habitat. The annual grassland habitat on site corresponds best to the non-native grassland habitat type of Holland (1986). The vegetation in the annual grassland habitat consists of species typical to highly disturbed habitats and are overall non-native weed species. The dominant grassland species consisted of wild oat (*Avena fatua*), rip-gut brome (*Bromus diandrus*), Mediterranean barley (*Hordeum murinum* var. *gussoneanum*) and annual rye grass (*Lolium multiflorum*). The forb species present consisted of annual weeds such as prickly lettuce (*Lactuca seriola*), cut-leaf geranium (*Geranium dissectum*), prickly lettuce (*Lactuca serriola*), and field bind weed (*Convolvulus arvensis*). The plants form an intermittent cover intermixed with bare ground and landscape plants over the project area and vary in height between a few inches and one to two feet tall.

##### ***Intermittent Drainage Ditch***

A shallow ditch (Stanford Avenue ditch) allows drainage of the surrounding topography from south to north along Stanford Avenue. Larger flows are only encountered during

the winter when storm runoff enters the ditch. The ditch consists of mostly non-vegetated clay banks with a scoured channel bottom. Vegetation recorded along the ditch included three primary species *Alisma lanceolata* (Water plantain-OBL), *Echinochloa crus-galli* (Rough barnyard grass- FACW), and *Cyperus esculentus* (Chufa-FACW). The banks contain no emergent vegetation or riparian habitat.

## **2.0 GOALS OF THE MITIGATION PLAN**

The first goal of the mitigation plan is to remove invasive exotic species from the riparian corridor along Matadero Creek which has been degraded by the spread of French broom and periwinkle (see Attachment 3, photo 3). The second goal of the plan is to plant riparian tree enhancement in mitigation for trees that are removed as a result of the Project.

The invasive species which are targeted for removal along Matadero Creek are French broom (*Genista monspessulana*.) and periwinkle (*Vinca minor*). Each species will require a different tactic for successful removal.

### **French Broom**

French broom is a small to medium sized shrub in the Fabaceae, the pea family, which has become naturalized in some portions of the state. It displaces native plant and forage species, and complete eradication is difficult. It out competes other species, forming a dense monospecific stand, often shading out native tree seedlings and all understory species. It is also extremely flammable, carrying flames into forest canopies, increasing both the frequency and intensity of wildfires. The removal of this species from the riparian area will greatly enhance the biological values of the corridor as native tree and shrub species will have the opportunity to regenerate.

Three approaches to French broom removal will likely need based on the size and age of the plants in the target area. A combination of hand pulling and mechanical removal will be necessary to accomplish the mitigation goals. The removal of sapling shrubs may be accomplished by hand when they are small whips and can be pulled out in the spring when the soils are wet. This is the easiest method for removal but is limited by the time of year and the size of the saplings.

Intermediate sized shrubs may be pulled out with a tool like a “weed wrench” which is a steel tool that grips the stem of the shrub at its base and levers the root system out of the ground. These tools have proven effective in removing French broom because the wrenches remove the entire shrub including the root system, thereby controlling resprouting. This technique is labor intensive, expensive, and can disturb the seedbank, releasing seeds which can increase infestation. It is crucial to monitor the project area and conduct follow-up work to check for newly germinated broom seedlings.



The largest sized shrubs would likely require the use of a chainsaw to remove the canopy and successive cuts at the main stems to clear away the plant. Root ball removal is essential as these plants stump sprout. Methods to clear the root ball or kill the root ball may be determined on an as needed basis. While painting the stump with an herbicide such as round up is known to be successful in controlling resprouts, this method will be avoided because this area of the Matadero Creek corridor has been designated a pesticide injunction area to protect sensitive local wildlife such as the California red-legged frog.

Depending upon the time of the year in which the shrub removal is to occur, varying degrees of caution may be used in storage and disposal of the vegetative material. It is highly recommended to remove plants between February and June, or before the plants have gone to seed. Removal of broom while in seed is not recommended due to the potential spread of seed. The roots of the broom plant are weakest when it is flowering so that time is the target period in which removal should occur. When removed later in the year after the seed pods are brown and mature, the seed pods explode and spread to new areas. Therefore, broom removal is recommended in April, May and early June when the flowers are in full bloom, and before the seed pods have begun to form. The plants are also easy to see and identify at that time.

If the broom removal is to occur after it has gone to seed, the plants should be placed on canvas sheets or within bags to minimize the spread of seeds. A metal debris box situated near Matador Creek is recommended to place the broom as it is removed from target areas. French broom plant material should be disposed at a facility in which it will not be used for landscaping chips or for other “recycled” products.

### **Periwinkle**

Periwinkle (*Vinca major*) is a spreading perennial vine with glabrous, dark green stems that contain a milky latex. The non-flowering stems grow close to the ground, rooting at the nodes and extending outward to three feet. Flowering stems grow erect to knee-high with solitary purple colored flowers developing in the leaf axil.

The first stage of control of periwinkle will be conducted by hand removal over a series of months. Successive pulling of periwinkle during the growing season will include the removal of stems and roots from the infestation area, taking care to completely remove any spreading roots growing below the surface. The repetition of pulling will capture a significant portion of the infestation. Over the course of three years the successive hand pulling of periwinkle should attain a high degree of success.

Periwinkle control should be conducted after a rain in early or late spring (April-15 though June 15) when soil moisture and air temperatures are at least 70 degrees Fahrenheit (the ideal temperature is 80 degrees Fahrenheit). Three successive years of treatment is anticipated to have great success in the elimination of this species from the corridor.

## **Tree Restoration Area**

The project will result in the removal of one oak tree for which tree mitigation is proposed at a 3:1 ratio in an open area along the Matadero Creek corridor (see Attachment 3, photo 4). Therefore a total of three live oak trees are proposed to mitigate those removed as a result of the Project. Due to planting restrictions along the corridor and the lack of supplemental irrigation water a species for species mitigation is not possible.

One gallon sized containers or the equivalent of less than one year old trees should be installed. The oaks trees will be planted within thirty feet of the creek channel such that ground water availability will be high. Simple planting techniques for these trees should include hole preparation with a shovel. Installation will be achieved by shoveling a hole that is twice as big as the restoration stock root ball. Soils within the planting pit will be loosened and workable such that the tree can be placed in the hole and earthen material backfilled. Trees shall be planted so no air pockets exist between the roots and the surrounding soils. Soils should be firmly tamped around the trees to stabilize the planting area. A wire root ball cage should be used to protect the trees from rodent predation underground. Above ground protection should include a tree collar to prevent above ground herbivory. Weed mat or mulch should be installed to minimize annual grass growth in a three foot diameter around the tree.

### **3.0 MONITORING PLAN**

Maintenance of non-native vegetation removal sites will continue for at least three growing seasons to allow the native riparian vegetation to reestablish. Monitoring of the banks will occur for five years. Remediation plans, including continued exotic control activities for up to five years, will be prepared and implemented in the event the target success criteria are not met at by the end of year three. Success of a mitigation project will be measured as follows:

- Approximately 85 percent removal of the mature French broom first year. All regrowth will be treated during yearly maintenance by ongoing hand pulling.
- Approximately 85 percent removal of periwinkle within three years from the target areas. All new shoots will be hand pulled during yearly maintenance.
- Survival of 100 percent of the mitigation trees.

#### **3.1 Annual Report**

A brief annual report shall be prepared that outlines the specific methods of exotic removal and the installation of mitigation trees in the Matadero Creek corridor. A visual inspection of the areas targeted for exotic removal should be conducted before and after work is conducted such that a comparison can be made from year to year. The first annual report should be compiled in the early spring following the first year of work and tree installation. Each successive annual report shall be prepared after inspection of the

work area in the early spring. Work can be targeted at problem areas as specified in the annual report. In summary the annual report shall include objectives, goals, methods, results and conclusions of the exotic removal and tree installation in the work area. Conclusions shall address the success of the work area in comparison to the goals as outlined above.

Annual reports will be submitted to the California Department of Fish and Game and the Regional Water Quality Control Board.

#### **4.0 LIVESTOCK EXCLUSION FENCES**

To improve existing wildlife habitat and water quality along an approximately 1,950-foot section and an approximately 1,470-foot section of Matadero Creek (3,420 feet total) Stanford has proposed to fence the creek from livestock, which are known to enter the creek from the adjacent property. Fence will be wildlife friendly as it will stop horses and cows, but will allow deer. Owing to fire-season concerns, fence construction will occur during the spring months when sparks from any required machinery will not come into contact with dry grasses.

##### **4.1 Fence Maintenance Plan**

The following Fence Maintenance Plan will be conducted by Stanford into perpetuity:

The exclusionary fence to the east of Matadero Creek will be maintained to ensure that cattle and horses do not enter the Matadero Creek riparian zone. Fences will also be monitored to protect resources in the Matadero Creek habitat area from unauthorized access. If unauthorized access is occurring through broken fences, it will be necessary to repair these areas if such access is causing potential harm to sensitive species. New fences will be constructed with three strands of smooth bottom wire to permit wildlife passage.

Annual fence inspections will be conducted in the spring by the Conservation Program Manager or Facility Operations personnel. Tasks will include the following:

- Monitoring fence lines, making recommendations to perform necessary fence repairs and replacement as needed.
- Repairing fence lines immediately if problems are noted or reported by personnel at other times of the year.

## **4.2 Responsible Party**

Contact information:

Alan Launer, PhD  
Conservation Program Manager  
Land, Buildings, and Real Estate  
Stanford University  
Stanford, California 94305  
aelauner@stanford.edu

# **ATTACHMENTS**

## **ATTACHMENT 1**

### **FIGURES**

<b>Figure 1</b>	<b>Regional Map</b>
<b>Figure 2</b>	<b>Vicinity Map</b>
<b>Figure 3</b>	<b>USGS Quadrangle Map</b>
<b>Figure 4</b>	<b>Aerial Map</b>
<b>Figure 5</b>	<b>Mitigation Map</b>
<b>Figure 6</b>	<b>Roth-Lomita Drainage</b>
<b>Figure 7</b>	<b>Matadero Creek Habitat Improvement Area</b>

**Figure 1**  
**Regional Map**

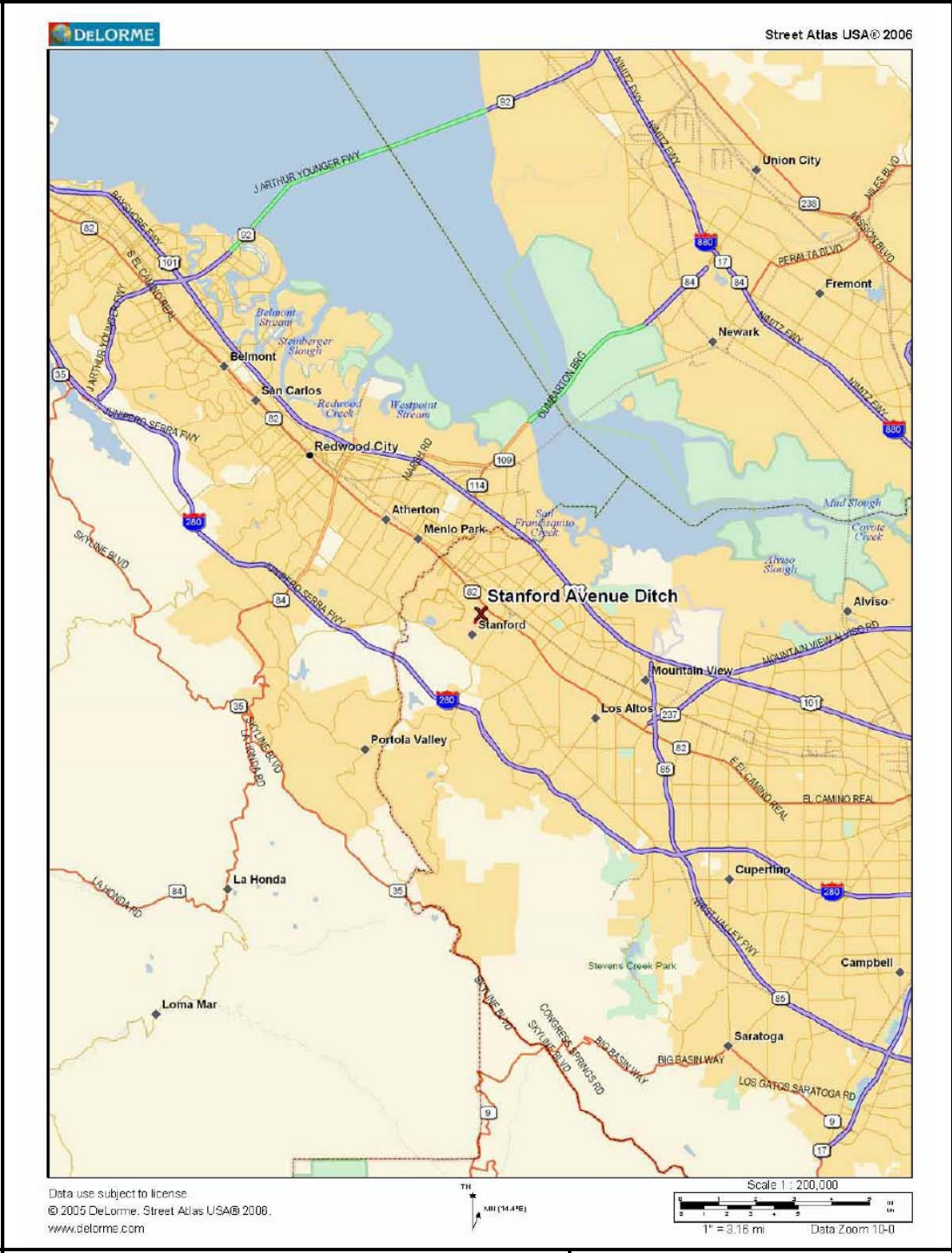

**Olberding Environmental, Inc.**  
 1390 Willow Pass Road, Suite 370  
 Concord, CA 94520  
 (925)825-2111 office  
 (925)825-2112 fax

**Figure 1**  
**Regional Map of the Olmsted Road**  
**Utilities Relocation Plan Project**  
 Stanford, California

This document is not intended for detail design work.



**Figure 2**  
**Vicinity Map**

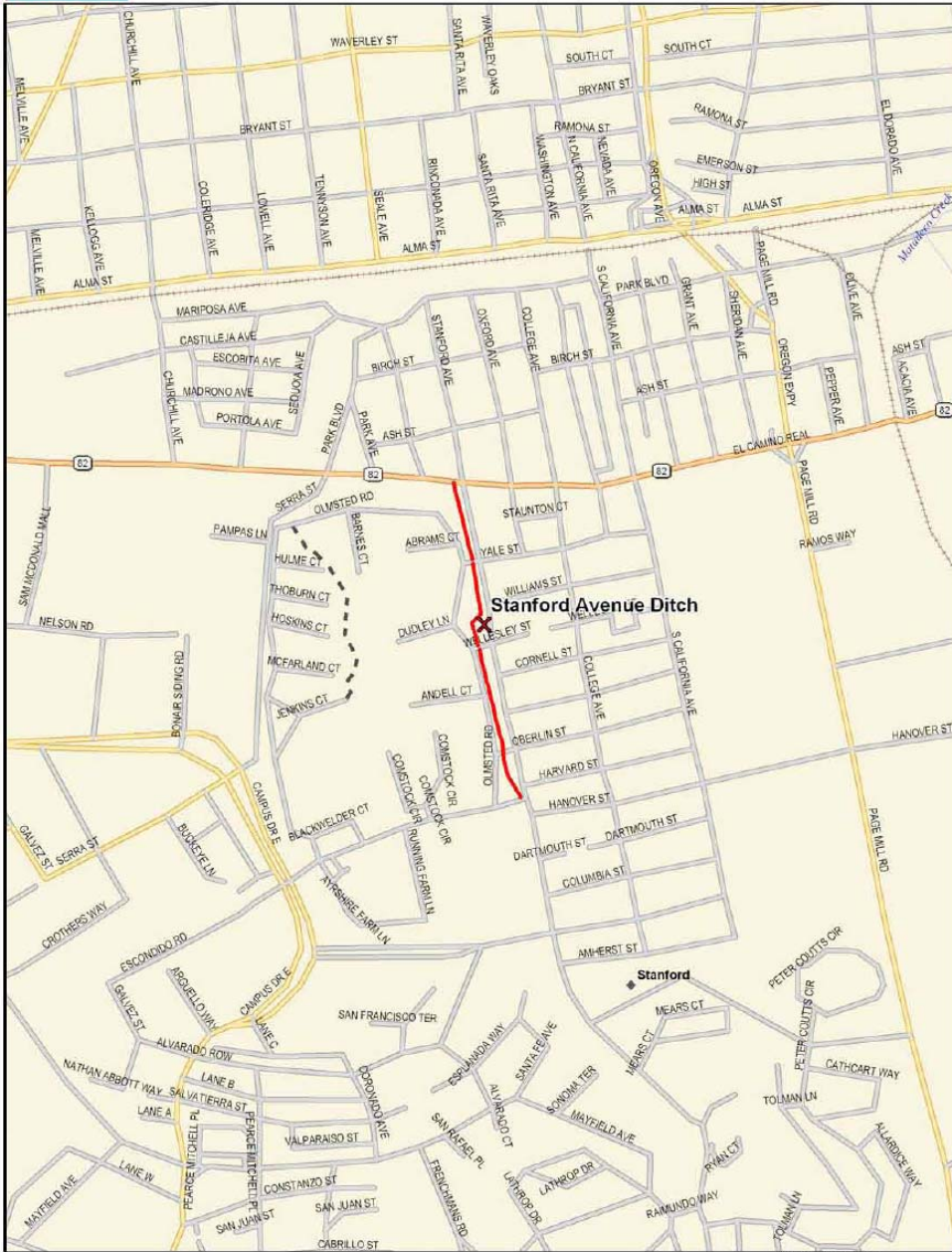

Data use subject to license  
 © 2005 DeLorme, Street Atlas USA © 2006.  
 www.delorme.com



**Olberding Environmental, Inc.**  
 1390 Willow Pass Road, Suite 370  
 Concord, CA 94520  
 (925)825-2111 office  
 (925)825-2112 fax

This document is not intended for detail design work.

**Figure 2**  
**Vicinity Map of the Olmsted Road**  
**Utilities Relocation Plan Project**  
 Stanford, California

**Figure 3**  
**USGS Quadrangle Map**

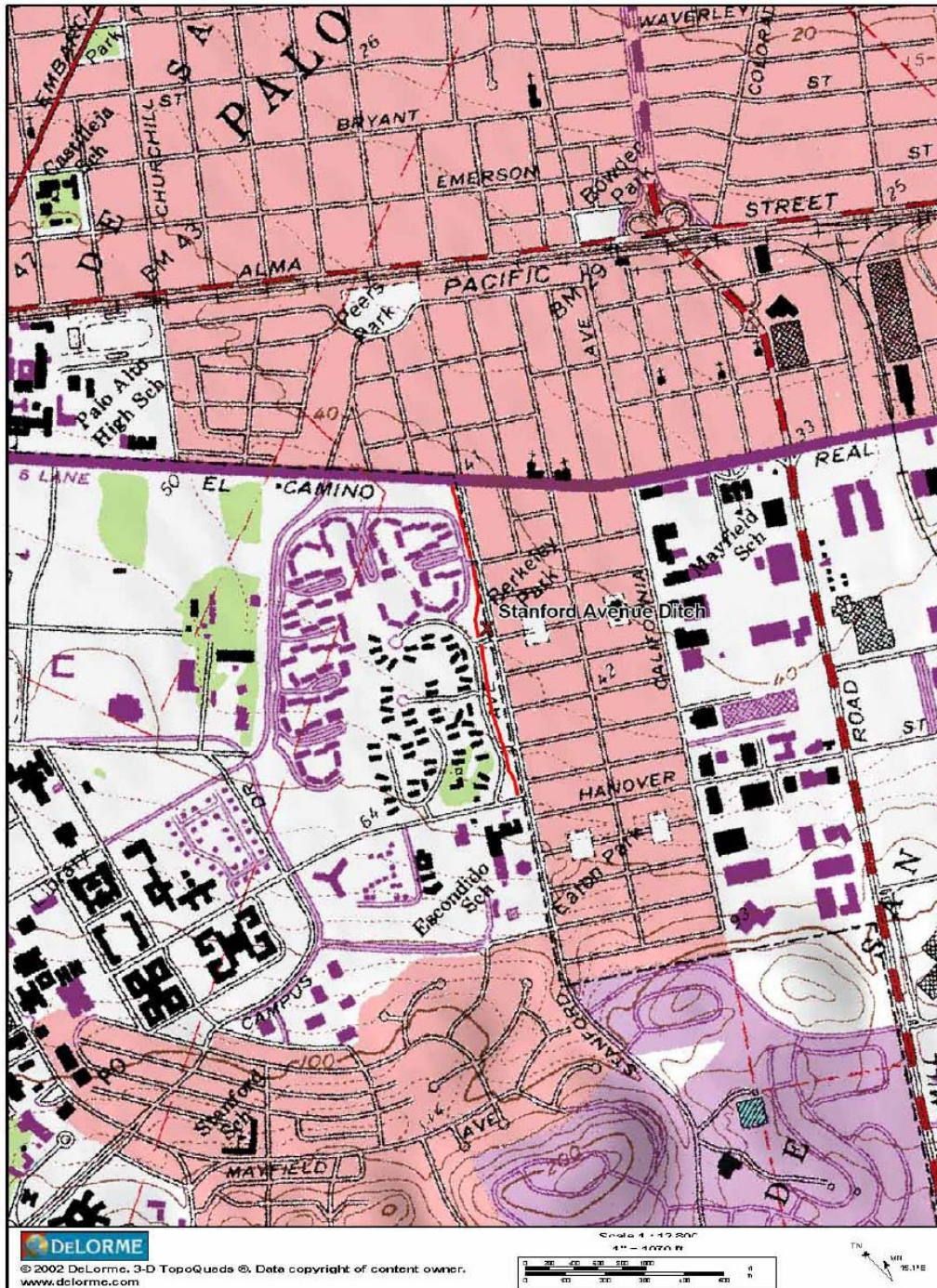

**Olberding Environmental, Inc.**  
 1390 Willow Pass Road, Suite 370  
 Concord, CA 94520  
 (925)825-2111 office  
 (925)825-2112 fax  
 This document is not intended for detail design work.

**Figure 3**  
**USGS Quadrangle Map of the Olmsted**  
**Road Utilities Relocation Plan Project**  
**USGS Quadrangle for Palo Alto**  
**Stanford, California**

**Figure 4**  
**Aerial Map**



**Olberding Environmental, Inc.**

1390 Willow Pass Road, Suite 370

Concord, CA 94520

(925)825-2111 office

(925)825-2112 fax

This document is not intended for detail design work.

**Figure 4**  
**Aerial of the Olmsted Road Utilities**  
**Relocation Plan Project**  
Stanford, California

**Figure 5**  
**Mitigation Map**

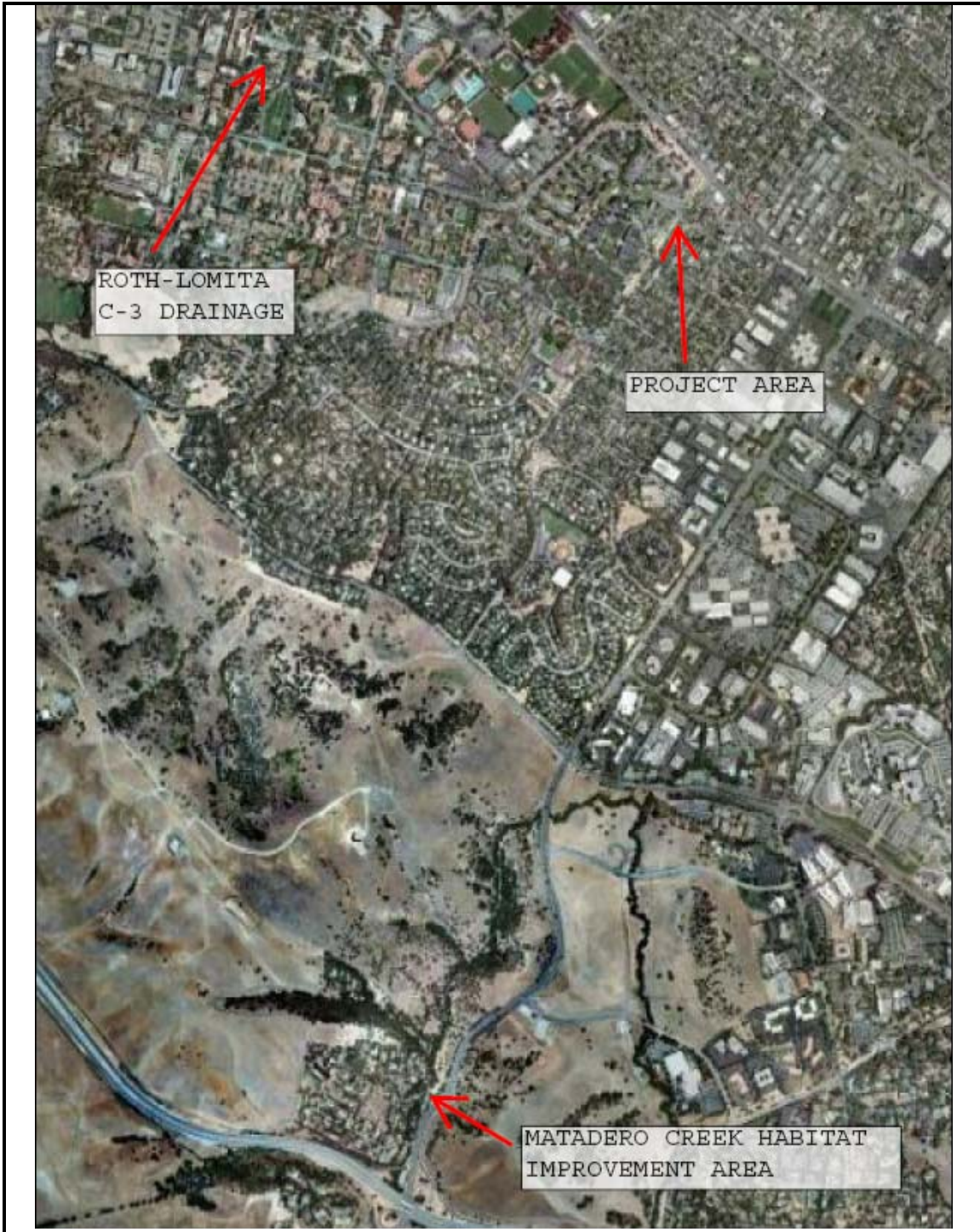

**Olberding Environmental, Inc.**

1390 Willow Pass Road, Suite 370

Concord, CA 94520

(925)825-2111 office

(925)825-2112 fax

This document is not intended for detail design work.

**Figure 5**

**Aerial map of the Mitigation Sites for the  
Olmsted Road Utilities Relocation Plan**

Stanford, California



**Figure 6**  
**Roth-Lomita Drainage**

DATE: 8/24/07 TIME: 11:51:18 AM DRAWING NAME: 5-DRAINAGE-45.DWG  
 SERVER: S:\S\11\115118\115118.dwg PLOTTING VIEW: P:\P\11\115118\115118.dwg  
 PLOTTER: HP-DesignJet 5000PS Color Plotter

PLAN # \_\_\_\_\_ OF \_\_\_\_\_ SHEET

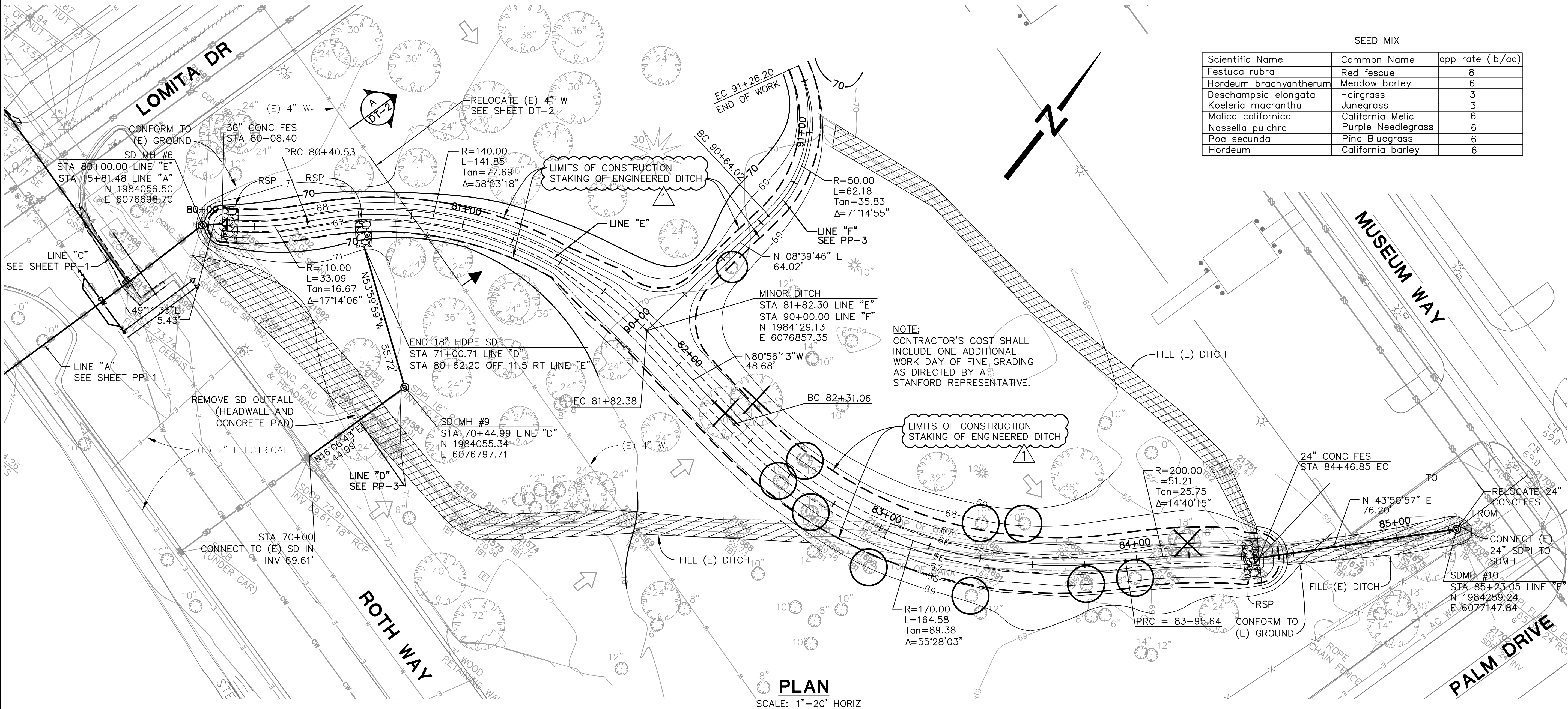

SEED MIX		
Scientific Name	Common Name	app rate (lb/ac)
Festuca rubra	Red fescue	8
Hordeum brachyantherum	Meadow barley	6
Deschampsia elongata	Hairgrass	3
Koeleria macrantha	Junegrass	3
Malica californica	California Melic	6
Nassella pulchra	Purple Needlegrass	6
Poa secunda	Pine Bluegrass	6
Hordeum	California barley	6

NOTE:  
 CONTRACTOR'S COST SHALL INCLUDE ONE ADDITIONAL WORK DAY OF FINE GRADING AS DIRECTED BY A STANFORD REPRESENTATIVE.

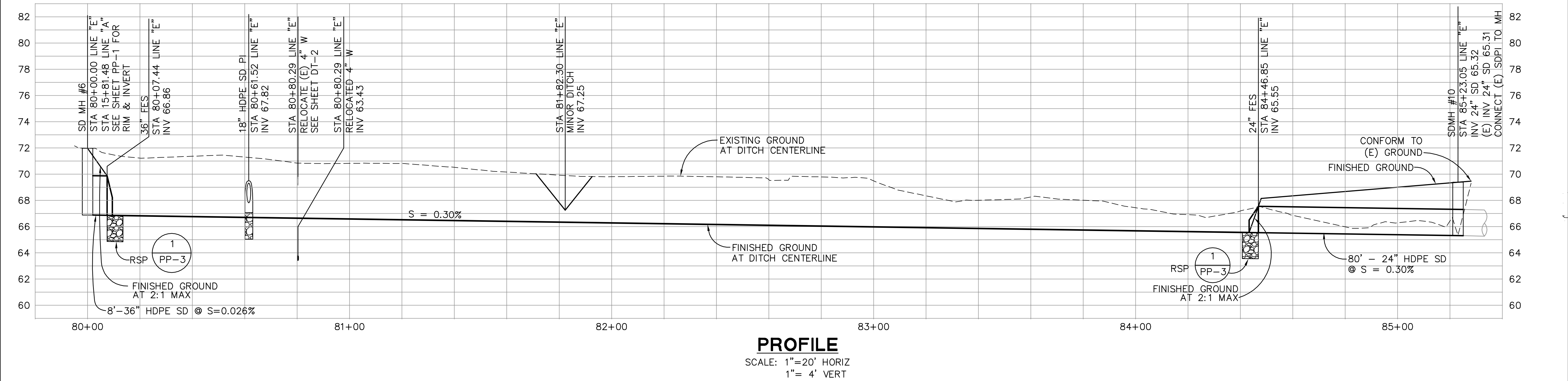

NO.	BY	DATE	REVISIONS
1	SSM	2/21/07	REVISED CONTOURS

STANFORD UNIVERSITY  
 ROTH AND LOMITA DRAINAGE IMPROVEMENTS  
 PLAN AND PROFILE  
 DITCH IMPROVEMENTS

PREPARED FOR: STANFORD UNIVERSITY DATE SUBMITTED: 12/13/06

**NOTE**  
 BEYOND ENGINEERING  
 1731 NORTH FIRST STREET, SUITE A  
 SAN JOSE, CA 95122  
 408.392.7200 TEL 408.392.0101 FAX  
 WWW.NOLTE.COM

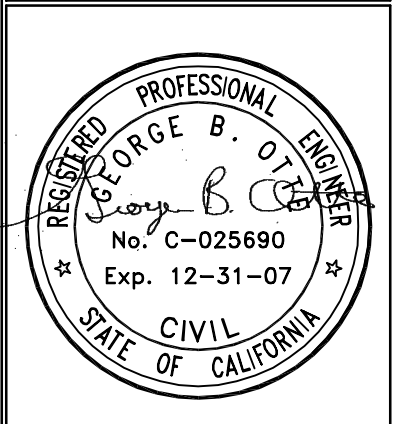

SHEET NUMBER  
**PP-2**  
 3 OF 7 SHEETS  
 SCALE  
 VERTICAL: 1"= 4'  
 HORIZONTAL: 1"= 20'  
 JOB NUMBER  
 SJ0066345

**Figure 7**  
**Matadero Creek Habitat Improvement Area**

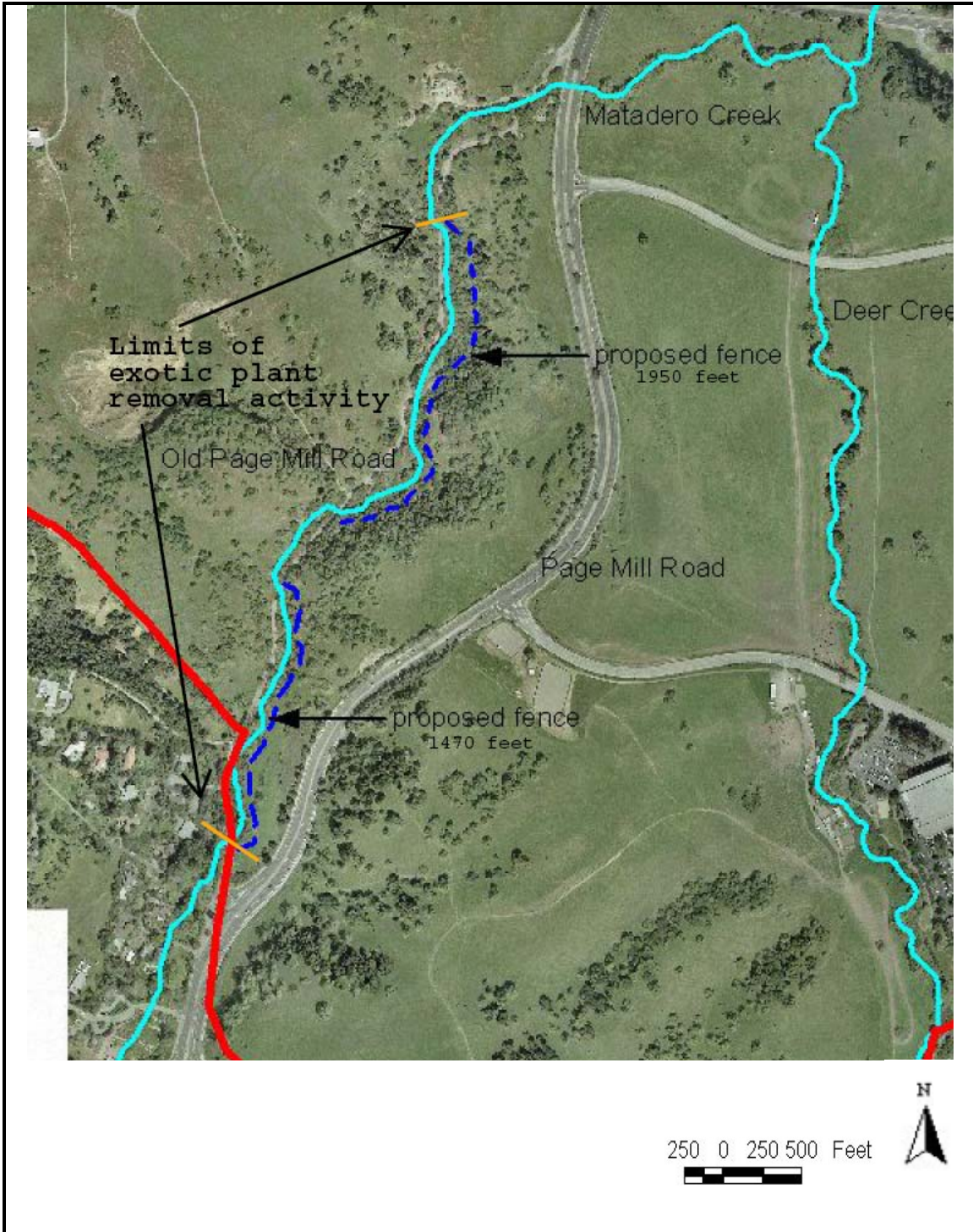



**Olberding Environmental, Inc.**  
 1390 Willow Pass Road, Suite 370  
 Concord, CA 94520  
 (925)825-2111 office  
 (925)825-2112 fax

This document is not intended for detail design work.

**Figure 7**  
**Matadero Creek Habitat Improvement**  
**Area for the Olmsted Road Utilities**  
**Relocation Plan**  
 Stanford, California

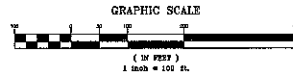
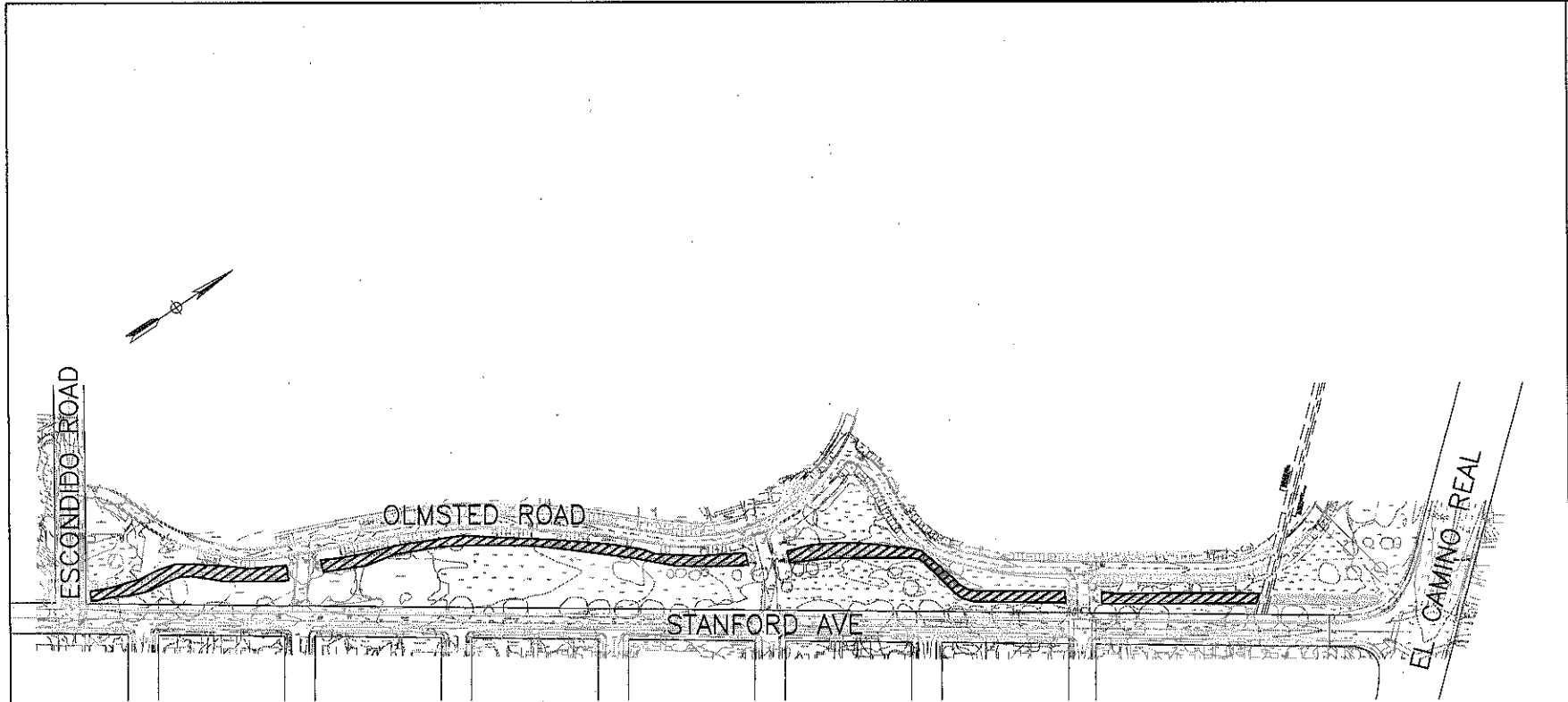
**ATTACHMENT 2  
DITCH EXHIBIT**



LEGEND:  
 LIMITS OF EXISTING DRAINAGE DITCH BEING DISPLACED

1830 TECHNOLOGY DRIVE  
 SUITE 200  
 SAN JOSE, CA 95131  
 408/437-1100  
 408/437-3189 (fax)



LIMITS OF EXISTING DRAINAGE  
 DITCH BEING DISPLACED  
 STANFORD AVENUE  
 SANTA CLARA  
 CALIFORNIA

PALO ALTO

Author	
Check	
Date	04-24-04
Scale	1"=100'
Design	
Drawn	
Approved	
Job No.	100000

Drawing Number  
**EXB-A**  
 1 of 1

**ATTACHMENT 3**  
**SITE PHOTOS**



**Photo 1. Stanford Avenue Ditch near Escondido Road, showing typical vegetated state.**



**Photo 2. Stanford Avenue Ditch near Escondido Village.**

**Olberding Environmental, Inc.  
Olmsted Road Utilities Relocation Plan  
March 2008**





**Photo 3. Pervasive periwinkle along Matadero Creek corridor.**



**Photo 4. Open area along Matadero Creek to be used for tree mitigation area.**

**Olberding Environmental, Inc.  
Olmsted Road Utilities Relocation Plan  
March 2008**

# **ATTACHMENT C**

*Conceptual Post-Construction Stormwater  
Treatment at the Stanford Avenue  
Residential Development*

1650 TECHNOLOGY DRIVE  
 SUITE 650  
 SAN JOSE, CA 95110  
 408-467-9100  
 408-467-9199 (FAX)

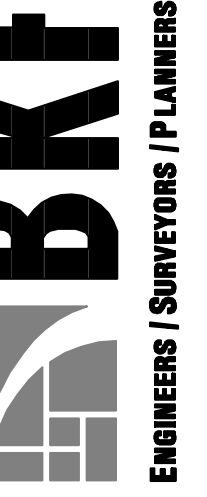

**STORMWATER TREATMENT CONCEPT  
 STANFORD HOUSING**

PALO ALTO SANTA CLARA COUNTY CALIFORNIA

Revisions	
No.	Date

Date: 07/30/07  
 Scale: 1"=50'  
 Design: TG  
 Drawn: TG  
 Approved: DT  
 Job No: 20066138-52

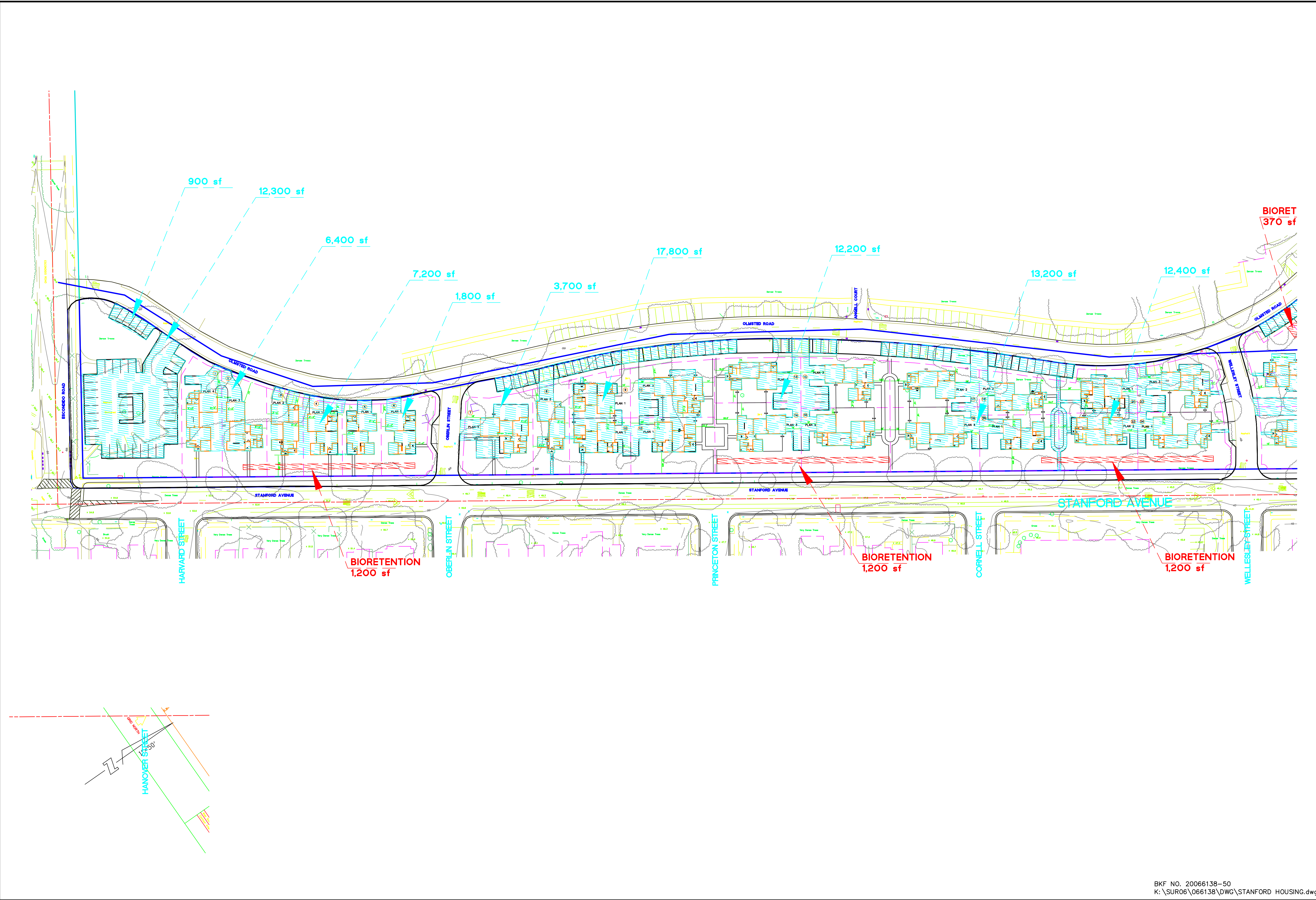

DATE PLOTTED: 08/01/07  
 PLOT FILE: C:\Users\jgarcia\Documents\Stanford Housing.dwg

1650 TECHNOLOGY DRIVE  
SUITE 650  
SAN JOSE, CA 95110  
408-467-9100 (FAX)  
408-467-9199 (FAX)



STORMWATER TREATMENT CONCEPT  
STANFORD HOUSING

PALO ALTO SANTA CLARA COUNTY CALIFORNIA

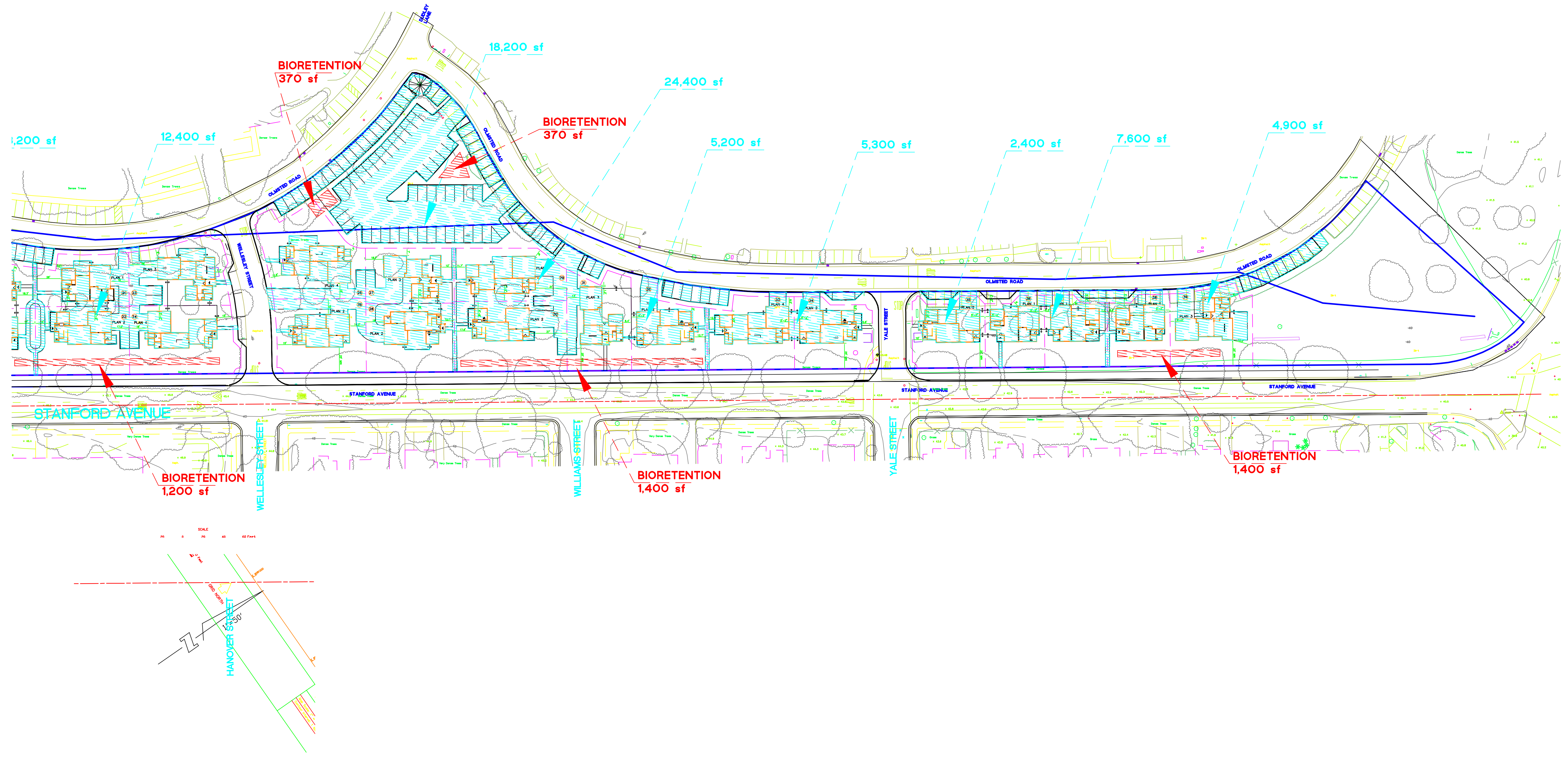

Revisions	
No.	Date
	07/30/07
	Scale: 1"=50'
	Design: TG
	Drawn: TG
	Approved: DT
	Job No: 20066138-52

Drawing Number: 2 OF 2

DATE PLOTTED: 07/30/07 10:58 AM  
PLOT FILE: C:\projects\stanford\stanford.dwg



255 Shoreline Drive, Suite 200  
Redwood City, CA 94065  
(650) 482-6300, Fax (650) 482-6399

## TECHNICAL MEMORANDUM

---

**Date:** March 28, 2008                      **BKF No.:** 20076072-10

**To:** **Phelicia Thompson, Stanford  
Utilities**

**cc:** **Rick Crosetti, Chris Birdwell  
Regis Homes**

**BKF, San Jose  
Richard Soto**

**From:** Ed Boscacci

**Subject: Stanford Avenue Faculty Housing  
Proposed Stormwater Treatment**

---

### STANFORD AVENUE HOUSING STORMWATER TREATMENT

The following presents the proposed stormwater treatment measures for the proposed Stanford Avenue Faculty Housing project. Stormwater will be treated in bioretention areas between the proposed housing and Stanford Avenue. The bioretention retention areas are sized with a treatment area equal to 4 percent of the contributing impervious area. This allows for treatment of a 0.2 inch per hour storm event with an infiltration rate of between 5 and 10 inches per hour. The bioretention area will consist of a 21-inch deep layer of a sand and compost mixture overlaying a 12-inch thick layer of drain rock containing perforated pipe.

Drainage areas are presented on Table 1 and are shown on Figures 1 and 2. The total project area is about 7.1 acres. The total impervious area will be about 3.6 acres. A total treatment area of 0.14 acres is proposed. The bioretention planting area will be installed adjacent to a pathway parallel to Stanford Avenue in the vicinity of the treatment areas shown on Figures 1 and 2.

STANFORD HOUSING

Table 1  
Stormwater Treatment Sizing

Impervious Area (square feet)		Treatment Area (square feet)
<b>Escondido Road to Oberlin Street</b>		
900	Parking	36
12,300	Parking	492
1,410	Parking	56
1,230	Parking	49
300	Parking	12
4,990		200
5,970		239
1,500		60
Subtotal, Escondido Road to Oberlin Street		1,144
<b>Oberlin Street to Wellesley Street</b>		
5,080	Parking	203
5,440	Parking	218
6,590	Parking	264
3,060	Parking	122
3,700		148
12,720		509
6,760		270
6,610		264
9,340		374
Subtotal, Oberlin Street to Wellesley Street		2,372
<b>Parking Area</b>		
18,200		728
<b>Wellesley Street to Yale Street</b>		
3,850	Parking	154
4,610	Parking	184
1,760	Parking	70
790	Parking	32
15,940		638
3,440		138
4,510		180
Subtotal, Wellesley Street to Yale Street		1,396
<b>Yale Street to Property Line</b>		
540	Parking	22
2,000	Parking	80
2,840	Parking	114
1,860		74
5,600		224
2,060		82
Subtotal, Yale Street to Property Line		596
(acres)		
Total Site	7.07	307,969
Impervious Area	3.58	155,900
<b>Percent Impervious 51%</b>		
Treatment Area	0.14	6,236
Impervious Area		3.58
Percent Impervious		51%
Parking	1.63	70,900
Roofs	1.56	68,000
Walkways, Misc	0.39	17,000
Existing Impervious		33,040

# CLEAN WATER PROGRAM QUESTIONNAIRE

(Please remove this sheet from information packet, fill out both sides, and submit this form with your land use application)

If you are unable to fill this out form out accurately, please ask your project civil engineer or architect to complete the form. Inaccurate responses delay processing.

- Project Name: (if any) Olmsted Road Storm Drain Relocation
- APN # 142 - 04 - 020 Building Inspection Office Plan Check # NA
- County Planning File # 9792 09 81 07 G
- Applicant Name: Stanford Real Estate
- Project Location: Stanford Campus - Olmsted Road  
(Street Address and City)

1. Project Type (check all that apply):

- Residential (Subdivision, not individual Single Family Dwelling)
- Commercial
- Industrial     Government: Name of Agency Stanford Campus - Maintenance

2. Project Size, Impervious Area, and Disturbed Area:

a. Total Site Area: 62,400 sq. ft.  
b. Existing (Pre-project) Impervious Surface Area 41,100 sq. ft.

Walkways 0 sq. ft.  
Roof areas 0 sq. ft.  
Parking lots 3,000 sq. ft.  
Other areas 38,100 sq. ft.

c. Total New or replacement Impervious Surface Area 41,100 sq. ft.

Walkways 0 sq. ft.  
Roof areas 0 sq. ft.  
Parking lots 3,000 sq. ft.  
Other areas 38,100 sq. ft.

= Replacement

d. Total (Post-Project) Impervious Surface Area (existing ~~XXXXXX~~ new) 41,100 sq. ft.

Replacement = Existing, No Increase

e. Percent of Increase and Replacement of Impervious Surface Area 0 %  
(c/b)\*100

**THERE ARE ADDITIONAL QUESTIONS, SO PLEASE TURN THIS PAGE OVER TO COMPLETE THE QUESTIONNAIRE**

f. Area of Land Disturbance During Construction 62,400 sq. ft.  
(includes clearing, grubbing, grading, filling, building, paving, installing septic tank system, installing water tanks, etc.)

3. Please report the types of Pesticide Reduction Measures proposed for your project (check all that apply):

Description

- Specific Landscape Design and Pesticide Reduction Certification by Licensed Landscape Architect.
- Does Not Apply. (i.e., no landscaping proposed or involved)
- Project maintains existing natural vegetation without using pesticides.

4. Please report the types of storm water controls planned (check all that apply):

Description No Treatment Required - Routine Maintenance

- Storm Water Treatment Measure (pollution treatment/removal)
- Source Control Measure (pollution prevention--by permanent BMPs)
- Site Design Measure (pollution prevention--by site layout)

5. Other water quality related permits that may be required from other agencies, i.e., Santa Clara Valley Water District Permit, Dept. of Fish and Game Stream Alteration Agreement, Regional Water Quality Control Board 401 Water Quality Certification, Army Corps of Engineers 404 Certification, etc.

Permits are not required from Santa Clara Valley Water District or Corps of Engineers. We are working with Fish & Game and Regional Water Quality Control Board to determine if permits are required. We will provide the County with confirmation when received.

6. List of all water related resources located on site, including water courses, drainage ditches, streams, wetlands, springs, seeps, water wells, detention ponds, natural ponds or lakes, man-made impoundments, and septic tank systems.

There is an unnamed drainage ditch that will be filled as a part of the project.

---

**DEPT. OF PLANNING AND DEVELOPMENT, LDE STAFF USE ONLY**

Questionnaire reviewed by LDE Staff (initials) \_\_\_\_\_ Date: \_\_\_\_\_

Project Category:  
(check one)

- Group 1       Group 1 & HMP
- Group 2A     Group 2B
- Exempt       Not in SF Bay Watershed



# CLEAN WATER PROGRAM QUESTIONNAIRE

(Please remove this sheet from information packet, fill out both sides,  
and submit this form with your land use application)

If you are unable to fill this out form out accurately, please ask your project civil engineer or architect to complete the form. Inaccurate responses delay processing.

- Project Name: (if any) Stanford Avenue Faculty Housing
- APN # 142 - 04 - 020 Building Inspection Office Plan Check # NA
- County Planning File # 9792 09 81 07 G
- Applicant Name: Stanford Real Estate
- Project Location: Stanford Campus - Olmsted Road  
(Street Address and City)

**1. Project Type (check all that apply):**

- Residential (Subdivision, not individual Single Family Dwelling)
- Commercial
- Industrial       Government: Name of Agency \_\_\_\_\_

**2. Project Size, Impervious Area, and Disturbed Area:**

- a. Total Site Area: 308,000 sq. ft.
- b. Existing (Pre-project) Impervious Surface Area 33,000 sq. ft.
  - Walkways 0 sq. ft.
  - Roof areas 0 sq. ft.
  - Parking lots 33,000 sq. ft.
  - Other areas \_\_\_\_\_ sq. ft.
- c. Total New or replacement Impervious Surface Area 156,000 sq. ft.
  - Walkways 0 sq. ft.
  - Roof areas 0 sq. ft.
  - Parking lots 3,000 sq. ft.
  - Other areas 38,100 sq. ft.
- d. Total (Post-Project) Impervious Surface Area (~~existing + new~~, or b+c) 156,000 sq. ft.
- e. Percent of Increase and Replacement of Impervious Surface Area 470 %  
(c/b)\*100

**THERE ARE ADDITIONAL QUESTIONS, SO PLEASE TURN  
THIS PAGE OVER TO COMPLETE THE QUESTIONNAIRE**

f. Area of Land Disturbance During Construction 308,000 sq. ft.  
(includes clearing, grubbing, grading, filling, building, paving, installing septic tank system, installing water tanks, etc.)

**3. Please report the types of Pesticide Reduction Measures proposed for your project (check all that apply):**

Description

- Specific Landscape Design and Pesticide Reduction Certification by Licensed Landscape Architect.
- Does Not Apply. (i.e., no landscaping proposed or involved)
- Project maintains existing natural vegetation without using pesticides.

**4. Please report the types of storm water controls planned (check all that apply):**

Description

- Storm Water Treatment Measure (pollution treatment/removal)
- Source Control Measure (pollution prevention--by permanent BMPs)
- Site Design Measure (pollution prevention--by site layout)

**5. Other water quality related permits that may be required from other agencies, i.e., Santa Clara Valley Water District Permit, Dept. of Fish and Game Stream Alteration Agreement, Regional Water Quality Control Board 401 Water Quality Certification, Army Corps of Engineers 404 Certification, etc.**

Permits are not required from Santa Clara Valley Water District or Corps of Engineers. We are working with Fish & Game and Regional Water Quality Control Board to determine if permits are required. We will provide the County with confirmation when received.

**6. List of all water related resources located on site, including water courses, drainage ditches, streams, wetlands, springs, seeps, water wells, detention ponds, natural ponds or lakes, man-made impoundments, and septic tank systems.**

There is an unnamed drainage ditch that will be filled as a part of the project.

---

**DEPT. OF PLANNING AND DEVELOPMENT, LDE STAFF USE ONLY**

Questionnaire reviewed by LDE Staff (initials) \_\_\_\_\_ Date: \_\_\_\_\_

- Project Category: (check one)**
- Group 1
  - Group 1 & HMP
  - Group 2A
  - Group 2B
  - Exempt
  - Not in SF Bay Watershed