

San Francisco Bay Regional Water Quality Control Board

TENTATIVE ORDER No. R2-2016-XXXX
NPDES No. CA0037966

The following discharger is subject to waste discharge requirements (WDRs) set forth in this Order.

Table 1. Discharger Information

Discharger	City of Calistoga
Facility Name	Dunaweal Wastewater Treatment Plant and its collection system
Facility Address	1100 Dunaweal Lane Calistoga, CA 94515 Napa County
CIWQS Place Number	212750

Table 2. Discharge Locations

Discharge Point	Effluent Description	Discharge Point Latitude (North)	Discharge Point Longitude (West)	Receiving Water
001	Tertiary-treated municipal wastewater	38.559444	-122.557778	Napa River
002	Secondary-treated municipal wastewater	38.570278	-122.561111	Napa River
003	Tertiary-treated municipal wastewater	38.569341	-122.556744	Napa River

Table 3. Administrative Information

This Order was adopted on:	DATE
This Order shall become effective on:	May 1, 2016
This Order shall expire on:	April 30, 2021
CIWQS Regulatory Measure Number	TBD
The Discharger shall file a Report of Waste Discharge as an application for reissuance of WDRs in accordance with California Code of Regulations, title 23, and an application for reissuance of a National Pollutant Discharge Elimination System (NPDES) permit no later than:	July 24, 2020
The U.S. Environmental Protection Agency (U.S. EPA) and the California Regional Water Quality Control Board, San Francisco Bay Region, have classified this discharge as follows:	Minor

I, Bruce H. Wolfe, Executive Officer, do hereby certify that this Order with all attachments is a full, true, and correct copy of the Order adopted by the California Regional Water Quality Control Board, San Francisco Bay Region, on the date indicated above.

Bruce H. Wolfe, Executive Officer

Contents

I.	Facility Information	4
II.	Findings.....	4
III.	Discharge Prohibitions.....	4
IV.	Effluent Limitations and Discharge Specifications	5
V.	Receiving Water Limitations	7
VI.	Provisions.....	8
	A. Standard Provisions	8
	B. Monitoring and Reporting	8
	C. Special Provisions	8
	1. Reopener Provisions.....	8
	2. Effluent Characterization Study and Report	9
	3. Receiving Water Characterization Study and Report.....	10
	4. Pollutant Minimization Program	11
	5. Special Provisions for Municipal Facilities.....	13
	6. Wastewater Pond Operation Requirements.....	14
	7. Anaerobically Digestible Material	14
	8. Conditions for Discharge Point No. 003	14
	9. Amendment of NPDES Permit No. CA0038849	15

Tables

Table 1.	Discharger Information.....	1
Table 2.	Discharge Locations	1
Table 3.	Administrative Information	1
Table 4.	Effluent Limitations.....	5

Attachments

Attachment A –	Definitions	A-1
Attachment B –	Facility Map.....	B-1
Attachment C –	Process Flow Diagram.....	C-1
Attachment D –	Federal Standard Provisions.....	D-1
Attachment E –	Monitoring and Reporting Program (MRP).....	E-1
Attachment F –	Fact Sheet.....	F-1
Attachment G –	Regional Standard Provisions and Monitoring and Reporting Requirements	G-1

I. FACILITY INFORMATION

Information describing the City of Calistoga Dunaweal Wastewater Treatment Plant and its associated collection system (collectively the Facility) is summarized in Table 1 and in Fact Sheet (Attachment F) sections I and II.

II. FINDINGS

The California Regional Water Quality Control Board, San Francisco Bay Region (Regional Water Board), finds:

- A. Legal Authorities.** This Order serves as WDRs pursuant to California Water Code article 4, chapter 4, division 7 (commencing with § 13260). This Order is also issued pursuant to federal Clean Water Act (CWA) section 402 and implementing regulations adopted by U.S. EPA, and Water Code chapter 5.5, division 7 (commencing with § 13370). It shall serve as an NPDES permit for point source discharges from the Facility to surface waters.
- B. Background and Rationale for Requirements.** The Regional Water Board developed the requirements in this Order based on information the Discharger submitted as part of its application, information obtained through monitoring and reporting programs, and other available information. The Fact Sheet (Attachment F) contains background information and rationale for the requirements in this Order and is hereby incorporated into and constitutes findings for this Order. Attachments A through E and G are also incorporated into this Order.
- C. Provisions and Requirements Implementing State Law.** Provision VI.C.6 is included to implement State law only (California Water Code section 13241). This provision is not required or authorized under the federal CWA; consequently, violations of this provision are not subject to the enforcement remedies available for NPDES violations.
- D. Notification of Interested Parties.** The Regional Water Board notified the Discharger and interested agencies and persons of its intent to prescribe these WDRs and provided an opportunity to submit written comments and recommendations. The Fact Sheet provides details regarding the notification.
- E. Consideration of Public Comment.** The Regional Water Board, in a public meeting, heard and considered all comments pertaining to the discharge. The Fact Sheet provides details regarding the public hearing.

THEREFORE, IT IS HEREBY ORDERED that Order No. R2-2010-0104 is rescinded upon the effective date of this Order except for enforcement purposes, and, in order to meet the provisions of Water Code division 7 (commencing with § 13000) and regulations adopted thereunder, and the provisions of the CWA and regulations and guidelines adopted thereunder, the Discharger shall comply with the requirements in this Order. This action in no way prevents the Regional Water Board from taking enforcement action for past violations of the previous order.

III. DISCHARGE PROHIBITIONS

- A.** Discharge of treated wastewater at a location or in a manner different from that described in this Order is prohibited.

- B.** Discharge at Discharge Point Nos. 001 and 003 is prohibited unless the river flow-to-effluent flow ratio is at least 10:1 (flows from Discharge Point Nos. 001 and 003 shall be combined in calculating this river flow-to-effluent flow ratio). Discharge at Discharge Point No. 002 is prohibited unless the river flow-to-effluent flow ratio is at least 50:1 (only the flow from Discharge Point No. 002 shall be considered in calculating this river flow-to-effluent flow ratio) and discharge from Discharge Point Nos. 001 and 003 is maximized. Compliance shall be achieved by proper operation and maintenance of the discharge outfalls to ensure that they (or their replacements, in whole or part) are in good working order and are consistent with or can achieve better mixing than that described in Fact Sheet section IV.C.4.a. The Discharger shall address measures taken to ensure this in its application for permit reissuance.
- C.** The bypass of untreated or partially-treated wastewater to waters of the United States is prohibited except as provided for in Attachment D section I.G.
- D.** Average dry weather influent flow in excess of 0.84 million gallons per day (MGD) is prohibited. Average dry weather influent flow shall be determined from three consecutive dry weather months each year, with compliance measured at Monitoring Location INF-001 as described in the Monitoring and Reporting Program (MRP).
- E.** Any sanitary sewer overflow that results in a discharge of untreated or partially-treated wastewater to waters of the United States is prohibited.
- F.** Discharge to the Napa River is prohibited during the dry season each year from June 16 through October 31. The need to discharge may arise as a result of early or late season storms. As soon as possible after determining that discharge will be necessary, the Discharger shall notify the Regional Water Board case manager by phone or email and provide information supporting its determination. Unless the case manager objects, the Discharger may commence discharge but only when absolutely necessary and only to the extent necessary for the reason stated above. The discharge shall be monitored and meet limitations, and shall consist of fully tertiary-treated effluent.

For each dry season discharge event, the Discharger shall submit a report within five business days after the end of the discharge that describes the reasons for the need to discharge, with supporting information, and describe the discharge flow volume, duration, and estimated dilution within the receiving water. In accordance with the Monitoring and Reporting Program (Attachment E), the discharge quality shall be reported in the next monthly self-monitoring report.

IV. EFFLUENT LIMITATIONS AND DISCHARGE SPECIFICATIONS

- A. Effluent Limitations.** The Discharger shall comply with the following effluent limitations at Discharge Point Nos. 001, 002, and 003, with compliance measured at Monitoring Locations EFF-001, EFF-002, and EFF-003 as described in the MRP.

Table 4. Effluent Limitations

Parameter	Units	Effluent Limitations				
		Average Monthly	Average Weekly	Maximum Daily	Instantaneous Minimum	Instantaneous Maximum
Discharge Point Nos. 001 and 003						
Biochemical Oxygen Demand, 5-day @ 20°C (BOD ₅)	mg/L	10	15	---	---	---

Parameter	Units	Effluent Limitations				
		Average Monthly	Average Weekly	Maximum Daily	Instantaneous Minimum	Instantaneous Maximum
Total Suspended Solids (TSS)	mg/L	15	20	---	---	---
Oil and Grease	mg/L	5	---	10	---	---
Turbidity	NTU	---	---	10	---	---
Discharge Point No. 002						
BOD ₅	mg/L	30	45	---	---	---
TSS	mg/L	30	45	---	---	---
Oil and Grease	mg/L	10	---	20	---	---
Discharge Point Nos. 001, 002, and 003						
pH ^[1]	standard units	---	---	---	6.5	8.5
Total Residual Chlorine	mg/L	---	---	---	---	0.0 ^[2]
Antimony, Total Recoverable	µg/L	25	---	36	---	---
Boron, Total Recoverable	µg/L	3,300	---	6,600	---	---
Cyanide, Total Recoverable	µg/L	7.3	---	18	---	---
Copper, Total Recoverable	µg/L	11	---	20	---	---
Chlorodibromomethane	µg/L	3.4	---	6.4	---	---
Dichlorobromomethane	µg/L	4.9	---	9.0	---	---
Total Ammonia	mg/L as N	12	---	55	---	---

Unit Abbreviations:

- mg/L = milligrams per liter
- mg/L as N = milligrams per liter as nitrogen
- µg/L = micrograms per liter
- NTU = Nephelometric Turbidity Unit
- TUc = Toxicity unit (chronic)

Footnotes:

- ^[1] If the Discharger monitors pH continuously, pursuant to 40 C.F.R. section 401.17 the Discharger shall be in compliance with this pH limitation provided that both of the following conditions are satisfied: (i) the total time during which the pH is outside the required range shall not exceed 7 hours and 26 minutes in any calendar month; and (ii) no individual excursion from the required pH range shall exceed 60 minutes.
- ^[2] The Discharger may elect to use a continuous on-line monitoring system for measuring or determining that residual dechlorinating agent is present. This monitoring system may be used to prove that anomalous residual chlorine exceedances measured by on-line chlorine analyzers are false positives because it is chemically improbable to have chlorine present in the presence of sodium bisulfite. If Regional Water Board staff finds convincing evidence that chlorine residual exceedances are false positives, the exceedances are not violations of this Order's total chlorine residual limit.

B. BOD₅ and TSS Percent Removal. The monthly average BOD₅ and TSS percent removal at Discharge Point Nos. 001, 002, and 003 shall be at least 85 percent by concentration (i.e., the monthly average BOD₅ and TSS concentrations measured at Monitoring Locations EFF-001, EFF-002, and EFF-003 as defined in the MRP shall be no greater than 15 percent of the monthly average concentrations measured at Monitoring Location INF-001 as defined in the MRP).

C. Total Coliform. Discharges at Discharge Point Nos. 001, 002, and 003 shall comply with the following total coliform limitations, with compliance measured at Monitoring Locations EFF-001, EFF-002, and EFF-003 as described in the MRP:

1. The median of all samples in each calendar month shall not exceed 23 Most Probable Number per hundred milliliters (MPN/100 mL).
2. The daily maximum shall not exceed 240 MPN/100 mL.

D. Whole Effluent Acute Toxicity. Discharges at Discharge Point Nos. 001, 002, and 003 shall comply with the following limitations, with compliance measured at Monitoring Locations EFF-001, EFF-002, and EFF-003 as described in the MRP. The survival of organisms shall be as follows:

1. An eleven (11) sample median value of not less than 90 percent survival, and
2. An eleven (11) sample 90th percentile value of not less than 70 percent survival.

These acute toxicity limitations are defined as follows:

- **11 sample median.** A bioassay test showing survival of less than 90 percent represents a violation of this effluent limit if five or more of the past ten or less bioassay tests show less than 90 percent survival.
- **90th percentile.** A bioassay test showing survival of less than 70 percent represents a violation of this effluent limit if one or more of the past ten or less bioassay tests show less than 70 percent survival.

V. RECEIVING WATER LIMITATIONS

A. The discharge shall not cause the following conditions to exist in receiving waters:

1. Floating material, including solids, liquids, foams, and scum, in concentrations that cause nuisance or adversely affect beneficial uses;
2. Alteration of suspended sediment in such a manner as to cause nuisance or adversely affect beneficial uses, or detrimental increase in the concentrations of toxic pollutants in sediments or aquatic life;
3. Suspended material in concentrations that cause nuisance or adversely affect beneficial uses;
4. Bottom deposits or aquatic growths to the extent that such deposits or growths cause nuisance or adversely affect beneficial uses;
5. Alteration of temperature beyond present natural background levels;
6. Changes in turbidity that cause nuisance or adversely affect beneficial uses, or increases from normal background light penetration or turbidity greater than 10 percent in areas where natural turbidity is greater than 50 nephelometric turbidity units (NTU);
7. Coloration that causes nuisance or adversely affects beneficial uses;
8. Visible, floating, suspended, or deposited oil or other products of petroleum origin; or
9. Toxic or other deleterious substances in concentrations or quantities that cause deleterious effects on wildlife, waterfowl, or other aquatic biota, or render any of these unfit for human consumption, either at levels created in the receiving waters or as a result of biological concentration.

B. The discharge shall not cause the following limitations to be exceeded in receiving waters at any place within one foot of the water surface:

1. Dissolved Oxygen 7.0 milligrams per liter (mg/L), minimum

The median dissolved oxygen concentration for any three consecutive months shall not be less than 80 percent of the dissolved oxygen content at saturation. When natural factors cause concentrations less than that specified above, the discharge shall not cause further reduction in ambient dissolved oxygen concentrations.

2. Dissolved Sulfide Natural background levels

3. Nutrients Waters shall not contain biostimulatory substances in concentrations that promote aquatic growths to the extent that such growths cause nuisance or adversely affect beneficial uses.

C. The discharge shall not cause a violation of any water quality standard for receiving waters adopted by the Regional Water Board or State Water Resources Control Board (State Water Board) as required by the CWA and regulations adopted thereunder. If more stringent water quality standards are promulgated or approved pursuant to CWA section 303, or amendments thereto, the Regional Water Board may revise or modify this Order in accordance with the more stringent standards.

VI. PROVISIONS

A. Standard Provisions

1. The Discharger shall comply with all provisions of the *Standard Provisions* (Attachment D).
2. The Discharger shall comply with all applicable provisions of the *Regional Standard Provisions, and Monitoring and Reporting Requirements for NPDES Wastewater Discharge Permits* (Attachment G).

B. Monitoring and Reporting

The Discharger shall comply with the MRP (Attachment E) and future revisions thereto, and applicable sampling and reporting requirements in Attachments D and G.

C. Special Provisions

1. Reopener Provisions

The Regional Water Board may modify or reopen this Order prior to its expiration date in any of the following circumstances as allowed by law:

- a. If present or future investigations demonstrate that the discharges governed by this Order have, will have, or will cease to have a reasonable potential to cause or contribute to adverse impacts on water quality or beneficial uses of the receiving waters.

- b. If new or revised water quality objectives or total maximum daily loads (TMDLs) come into effect (whether statewide, regional, or site-specific). In such cases, effluent limitations in this Order may be modified as necessary to reflect the updated water quality objectives and wasteload allocations in the TMDLs. Adoption of the effluent limitations in this Order is not intended to restrict in any way future modifications based on legally-adopted water quality objectives or TMDLs or as otherwise permitted under federal regulations governing NPDES permit modifications.
- c. If translator, dilution, or other water quality studies provide a basis for determining that a permit condition should be modified.
- d. If State Water Board precedential decisions, new policies, new laws, or new regulations are adopted.
- e. If an administrative or judicial decision on a separate NPDES permit or WDRs addresses requirements similar to this discharge.
- f. If the Discharger requests adjustments in effluent limits due to the implementation of stormwater diversion pursuant to the Municipal Regional Stormwater Permit (Permit No. CAS612008) for redirecting dry weather and first flush discharges from the storm drain system to the sanitary sewer system as a storm water pollutant control strategy.
- g. Or as otherwise authorized by law.

The Discharger may request a permit modification based on any of the circumstances above. With any such request, the Discharger shall include antidegradation and anti-backsliding analyses.

2. Effluent Characterization Study and Report

- a. **Study Elements.** The Discharger shall continue to characterize and evaluate the discharge from the following discharge points to verify that the “no” or “unknown” reasonable potential analysis conclusions of this Order remain valid and to inform the next permit reissuance. The Discharger shall collect representative samples at the monitoring stations set forth below, as defined in the MRP, at no less than the frequency specified below:

<u>Discharge Point</u>	<u>Monitoring Location</u>	<u>Minimum Frequency</u>
001	EFF-001	Once
002	EFF-002	Once
003	EFF-003	Once

The samples shall be analyzed for the pollutants listed in Attachment G, Table C, except for those pollutants with effluent limitations where the MRP already requires more frequent monitoring, and except for those pollutants for which there are no water quality criteria (see Fact Sheet Table F-7). Samples shall also be analyzed for the pollutants listed in Basin Plan Tables 3-5 and 3-6, except for odor and radioactivity (see Fact Sheet Table F-8). Compliance with this requirement shall be achieved in accordance with the specifications of Attachment G sections III.A.1 and III.A.2.

The Discharger shall evaluate whether concentrations of any of these pollutants significantly increase over past performance. The Discharger shall investigate the cause of any such increase. The investigation may include, but need not be limited to, an increase in monitoring frequency, monitoring of internal process streams, and monitoring of influent sources. The Discharger shall establish remedial measures addressing any increase resulting in reasonable potential to cause or contribute to an excursion above applicable water quality objectives. This requirement may be satisfied through identification of the constituent as a “pollutant of concern” in the Discharger’s Pollutant Minimization Program, described in Provision VI.C.4.

b. Reporting Requirements

- i. Routine Reporting.** The Discharger shall, within 45 days of receipt of analytical results, report the following in the transmittal letter for the appropriate self-monitoring report:
 - (a)** Indication that a sample for this characterization study was collected; and
 - (b)** Identity of pollutants detected at or above applicable water quality criteria (see Fact Sheet Tables F-7 and F-8 for the criteria) and the detected concentrations of those pollutants.
- ii. Final Report.** The Discharger shall submit a final report that presents all these data with the application for permit reissuance.

3. Receiving Water Characterization Study and Report

- a. Study Elements.** The Discharger shall characterize and evaluate the receiving water at the following discharge points to verify that the “no” or “unknown” reasonable potential analysis conclusions of this Order remain valid and to inform the next permit reissuance. The Discharger shall collect representative samples at the monitoring stations set forth below, as defined in the MRP, at no less than the frequency specified below:

<u>Monitoring Location</u>	<u>Minimum Frequency</u>
RSW-001, RSW-005, and RSW-007 (or RSW-900)	Once

At Monitoring Locations RSW-001, RSW-005, and, if Discharge Point No. 003 is constructed and authorized pursuant to Provision VI.C.8, RSW-007 (or at Monitoring Location RSW-900 if meeting this requirement through collaborative monitoring), the samples shall be analyzed for the pollutants listed in Attachment G, Table C, except for those pollutants for which there are no water quality criteria (see Fact Sheet Table F-7). These samples shall also be analyzed for the pollutants listed in Basin Plan Tables 3-5 and 3-6, except for odor and radioactivity (see Fact Sheet Table F-8). Compliance with this requirement shall be achieved in accordance with the specifications of Attachment G sections III.A.1 and III.A.2.

The Discharger may complete this study on its own or in collaboration with other Napa River dischargers (i.e., the cities of Yountville and St. Helena).

b. Reporting Requirements

- i. **Routine Reporting.** The Discharger shall, within 45 days of receipt of analytical results, report the following in the transmittal letter for the appropriate self-monitoring report:
 - (a) Indication that a sample for this study was collected; and
 - (b) Identity of pollutants detected at or above applicable water quality criteria (see Fact Sheet Tables F-7 and F-8) and the detected concentrations of those pollutants.
- ii. **Final Report.** The Discharger shall submit a final report that presents all these data with the application for permit reissuance.

4. Pollutant Minimization Program

- a. The Discharger shall continue to improve its existing Pollutant Minimization Program to promote minimization of pollutant loadings to the treatment plant and therefore to the receiving waters.
- b. The Discharger shall submit an annual report no later than February 28 each year. Each annual report shall include at least the following information:
 - i. **Brief description of treatment plant.** The description shall include the service area and treatment plant processes.
 - ii. **Discussion of current pollutants of concern.** Periodically, the Discharger shall analyze its circumstances to determine which pollutants are currently a problem and which pollutants may be potential future problems. This discussion shall include the reasons for choosing the pollutants.
 - iii. **Identification of sources for pollutants of concern.** This discussion shall include how the Discharger intends to estimate and identify pollutant sources. The Discharger shall include sources or potential sources not directly within the ability or authority of the Discharger to control, such as pollutants in the potable water supply and air deposition.
 - iv. **Identification of tasks to reduce the sources of pollutants of concern.** This discussion shall identify and prioritize tasks to address the Discharger's pollutants of concern. The Discharger may implement the tasks by itself or participate in group, regional, or national tasks that address its pollutants of concern. The Discharger is strongly encouraged to participate in group, regional, or national tasks that address its pollutants of concern whenever it is efficient and appropriate to do so. An implementation timeline shall be included for each task.
 - v. **Outreach to employees.** The Discharger shall inform employees about the pollutants of concern, potential sources, and how they might be able to help reduce the discharge of these pollutants of concern into the treatment facilities. The Discharger may provide a forum for employees to provide input.

- vi. Continuation of Public Outreach Program.** The Discharger shall prepare a pollution prevention public outreach program for its service area. Outreach may include participation in existing community events, such as county fairs; initiating new community events, such as displays and contests during Pollution Prevention Week; conducting school outreach programs; conducting plant tours; and providing public information in newspaper articles or advertisements, radio or television stories or spots, newsletters, utility bill inserts, or web sites. Information shall be specific to target audiences. The Discharger shall coordinate with other agencies as appropriate.
- vii. Discussion of criteria used to measure Pollutant Minimization Program and task effectiveness.** The Discharger shall establish criteria to evaluate the effectiveness of its Pollutant Minimization Program. This discussion shall identify the specific criteria used to measure the effectiveness of each task in Provisions VI.C.3.b.iii, iv, v, and vi.
- viii. Documentation of efforts and progress.** This discussion shall detail all of the Discharger's Pollutant Minimization Program activities during the reporting year.
- ix. Evaluation of Pollutant Minimization Program and task effectiveness.** The Discharger shall use the criteria established in Provision VI.C.3.b.vii to evaluate the program and task effectiveness.
- x. Identification of specific tasks and timelines for future efforts.** Based on the evaluation, the Discharger shall explain how it intends to continue or change its tasks to more effectively reduce the amount of pollutants flowing to the treatment plant, and subsequently in its effluent.
- c.** The Discharger shall develop and conduct a Pollutant Minimization Program as further described below when there is evidence that a priority pollutant is present in the effluent above an effluent limitation (e.g., sample results reported as detected but not quantified [DNQ] when the effluent limitation is less than the method detection limit [MDL], sample results from analytical methods more sensitive than those methods required by this Order, presence of whole effluent toxicity, health advisories for fish consumption, or results of benthic or aquatic organism tissue sampling) and either:

 - i.** A sample result is reported as DNQ and the effluent limitation is less than the Reporting Level (RL); or
 - ii.** A sample result is reported as not detected (ND) and the effluent limitation is less than the MDL, using definitions in Attachment A and reporting protocols described in the MRP.
- d.** If triggered by the reasons set forth in Provision VI.C.3.c, above, the Discharger's Pollutant Minimization Program shall include, but not be limited to, the following actions and submittals:

 - i.** Annual review and semi-annual monitoring of potential sources of the reportable priority pollutants, which may include fish tissue monitoring and other bio-uptake sampling, or alternative measures when source monitoring is unlikely to produce useful analytical data;

- ii. Quarterly monitoring for the reportable priority pollutants in the influent to the Facility. The Executive Officer may approve alternative measures when influent monitoring is unlikely to produce useful analytical data;
- iii. Submittal of a control strategy designed to proceed toward the goal of maintaining concentrations of the reportable priority pollutants in the effluent at or below the effluent limitation;
- iv. Implementation of appropriate cost-effective control measures for the reportable priority pollutants, consistent with the control strategy; and
- v. Inclusion of the following specific items within the annual report required by Provision VI.C.3.b above:
 - (a) All Pollutant Minimization Program monitoring results for the previous year;
 - (b) List of potential sources of the reportable priority pollutants;
 - (c) Summary of all actions undertaken pursuant to the control strategy; and
 - (d) Description of actions to be taken in the following year.

5. Special Provisions for Municipal Facilities

a. Sludge and Biosolids Management

- i. All sludge and biosolids shall be disposed of, managed, or reused in a municipal solid waste landfill; through land application; as a Class A compost; through a waste-to-energy facility or another recognized and approved technology; in a sludge-only landfill; or in a sewage sludge incinerator in accordance with 40 C.F.R. part 503.
- ii. Sludge and biosolids treatment, storage, and disposal, or reuse, shall not create a nuisance, such as objectionable odors or flies, or result in groundwater contamination.
- iii. The sludge and biosolids treatment and storage site shall have facilities adequate to divert surface runoff from adjacent areas, to protect site boundaries from erosion, and to prevent any conditions that would cause drainage from the materials in the storage site. Adequate protection is defined as protection from at least a 100-year storm and the highest possible tidal stage that may occur.
- iv. Sludge or biosolids disposed in a municipal solid waste landfill shall meet the requirements of 40 C.F.R. part 258.
- v. This Order does not authorize permanent onsite sludge or biosolids storage or disposal. A Report of Waste Discharge shall be filed and the site brought into compliance with all applicable regulations prior to commencement of any such activity.

- b. **Collection System Management.** The Discharger shall properly operate and maintain its collection system (see Attachment D section I.D). The Discharger shall report any

noncompliance (see Attachment D sections V.E.1 and V.E.2) and mitigate any discharge from its collection system that violates this Order (see Attachment D section I.C).

The *Statewide General Waste Discharge Requirements for Sanitary Sewer Systems* (General Collection System WDRs), State Water Board Order No. 2006-0003 DWQ as amended by State Water Board Order No. WQ 2013-0058-EXEC, has requirements for operation and maintenance of separate sanitary sewer collection systems and for reporting and mitigating sanitary sewer overflows from the separate sanitary sewer portion of the Discharger's collection system. While the Discharger must comply with both the General Collection System WDRs and this Order, the General Collection System WDRs more clearly and specifically stipulate requirements for operation and maintenance and for reporting and mitigating sanitary sewer overflows. Implementation of the General Collection System WDRs for proper operation and maintenance and mitigation of sanitary sewer overflows will satisfy the corresponding federal NPDES requirements specified in Attachment D (as supplemented by Attachment G). Following the notification and reporting requirements in the General Collection System WDRs will satisfy NPDES the corresponding reporting requirements specified in Attachment D (as supplemented by Attachment G) for sanitary sewer overflows from the separate sanitary sewer portion of the collection system.

6. Wastewater Pond Operation Requirements

Wastewater within one foot of the surface of all wastewater ponds shall meet the following limits:

- a. Dissolved Oxygen: 2.0 mg/L, minimum
- b. Dissolved Sulfide: 0.1 mg/L, maximum

7. Anaerobically Digestible Material

If the Discharger receives hauled-in anaerobically-digestible material for injection into an anaerobic digester, the Discharger shall notify the Regional Water Board and develop and implement Standard Operating Procedures for this activity. The Standard Operating Procedures shall be developed prior to initiation of hauling. The Standard Operating Procedures shall address material handling, including unloading, screening, or other processing prior to anaerobic digestion; transportation; spill prevention; spill response; avoidance of the introduction of materials that could cause interference, pass through, or upset of the treatment processes; avoidance of prohibited material; vector control; odor control; operation and maintenance; and the disposition of any solid waste segregated from introduction to the digester. The Discharger shall train its staff on the Standard Operating Procedures and maintain records for a minimum of three years for each load received, describing the hauler, waste type, and quantity received. In addition, the Discharger shall maintain records for a minimum of three years for the disposition, location, and quantity of cumulative pre-digestion segregated solid waste hauled offsite.

8. Conditions for Discharge Point No. 003

If and when the Discharger constructs Discharge Point No. 003 (as described in Fact Sheet section IV.C.4.a), it shall submit the following documentation prior to discharge:

- a. Physical description of the discharge pipeline and outfall structure, including as-built outfall latitude and longitude that are not different than those in Table 2 by more than five percent, and measures to prevent erosion.
- b. Documentation that measures to control chlorodibromomethane and dichlorobromomethane are installed, operational, and sufficient to ensure compliance with effluent limits.
- c. Certification by a licensed professional that the new outfall has been constructed as designed and permitted and is ready for use;
- d. Updates to the Operations and Maintenance Manual and Contingency Plan that reflect the new outfall; and
- e. The specific date the Discharger proposes to commence use of the new outfall.

The Discharger shall commence use of the new outfall only after the Executive Officer concurs that these conditions have been met.

9. Amendment of NPDES Permit No. CA0038849

NPDES Permit No. CA0038849 (Order No. R2-2012-0096) shall be amended as follows:

- a. Table 2A of Order No. R2-2012-0096 shall list Discharge Points 001, 002, and 003 for Calistoga.
- b. Table E-1 of Order No. R2-2012-0096 shall state, "For Calistoga, monitoring shall occur at the main discharge point, EFF-001 or EFF-003."

ATTACHMENT A – DEFINITIONS

Arithmetic Mean (μ)

Also called the average, the sum of measured values divided by the number of samples. For ambient water concentrations, the arithmetic mean is calculated as follows:

$$\text{Arithmetic mean} = \mu = \Sigma x / n \quad \text{where: } \Sigma x \text{ is the sum of the measured ambient water concentrations, and } n \text{ is the number of samples.}$$

Average Monthly Effluent Limitation (AMEL)

The highest allowable average of daily discharges over a calendar month, calculated as the sum of all daily discharges measured during a calendar month divided by the number of daily discharges measured during that month.

Average Weekly Effluent Limitation (AWEL)

The highest allowable average of daily discharges over a calendar week (Sunday through Saturday), calculated as the sum of all daily discharges measured during a calendar week divided by the number of daily discharges measured during that week.

Bioaccumulative

Taken up by an organism from its surrounding medium through gill membranes, epithelial tissue, or from food and subsequently concentrated and retained in the body of the organism.

Carcinogenic

Known to cause cancer in living organisms.

Coefficient of Variation

Measure of data variability calculated as the estimated standard deviation divided by the arithmetic mean of the observed values.

Daily Discharge

Either: (1) the total mass of the constituent discharged over the calendar day (12:00 am through 11:59 pm) or any 24-hour period that reasonably represents a calendar day for purposes of sampling (as specified in the permit) for a constituent with limitations expressed in units of mass; or (2) the unweighted arithmetic mean measurement of the constituent over the day for a constituent with limitations expressed in other units of measurement (e.g., concentration).

The daily discharge may be determined by the analytical results of a composite sample taken over the course of one day (a calendar day or other 24-hour period defined as a day) or by the arithmetic mean of analytical results from one or more grab samples taken over the course of the day.

For composite sampling, if 1 day is defined as a 24-hour period other than a calendar day, the analytical result for the 24-hour period is considered the result for the calendar day in which the 24-hour period ends.

Detected, but Not Quantified (DNQ)

Sample result less than the RL, but greater than or equal to the laboratory's MDL. Sample results reported as DNQ are estimated concentrations.

Dilution Credit

Amount of dilution granted to a discharge in the calculation of a water quality-based effluent limitation, based on the allowance of a specified mixing zone. It is calculated from the dilution ratio or determined by conducting a mixing zone study or modeling the discharge and receiving water.

Effluent Concentration Allowance (ECA)

Value derived from the water quality criterion/objective, dilution credit, and ambient background concentration that is used, in conjunction with the CV for the effluent monitoring data, to calculate a long-term average (LTA) discharge concentration. The ECA has the same meaning as waste load allocation (WLA) as used in U.S. EPA guidance (*Technical Support Document For Water Quality-based Toxics Control*, March 1991, second printing, EPA/505/2-90-001).

Enclosed Bay

Indentation along the coast that encloses an area of oceanic water within a distinct headlands or harbor works. Enclosed bays include all bays where the narrowest distance between the headlands or outermost harbor works is less than 75 percent of the greatest dimension of the enclosed portion of the bay. Enclosed bays include, but are not limited to, Humboldt Bay, Bodega Harbor, Tomales Bay, Drake's Estero, San Francisco Bay, Morro Bay, Los Angeles-Long Beach Harbor, Upper and Lower Newport Bay, Mission Bay, and San Diego Bay. Enclosed bays do not include inland surface waters or ocean waters.

Estimated Chemical Concentration

Concentration that results from the confirmed detection of the substance below the ML value by the analytical method.

Estuaries

Waters, including coastal lagoons, located at the mouths of streams that serve as areas of mixing for fresh and ocean waters. Coastal lagoons and mouths of streams that are temporarily separated from the ocean by sandbars are considered estuaries. Estuarine waters are considered to extend from a bay or the open ocean to a point upstream where there is no significant mixing of fresh water and seawater. Estuarine waters include, but are not limited to, the Sacramento-San Joaquin Delta, as defined in Water Code section 12220, Suisun Bay, Carquinez Strait downstream to the Carquinez Bridge, and appropriate areas of the Smith, Mad, Eel, Noyo, Russian, Klamath, San Diego, and Otay rivers. Estuaries do not include inland surface waters or ocean waters.

Inland Surface Waters

All surface waters of the state that do not include the ocean, enclosed bays, or estuaries.

Instantaneous Maximum Effluent Limitation

Highest allowable value for any single grab sample or aliquot (i.e., each grab sample or aliquot is independently compared to the instantaneous maximum limitation).

Instantaneous Minimum Effluent Limitation

Lowest allowable value for any single grab sample or aliquot (i.e., each grab sample or aliquot is independently compared to the instantaneous minimum limitation).

Maximum Daily Effluent Limitation (MDEL)

Highest allowable daily discharge of a pollutant, over a calendar day (or 24-hour period). For pollutants with limitations expressed in units of mass, the daily discharge is calculated as the total mass of the pollutant discharged over the day. For pollutants with limitations expressed in other units of measurement, the daily discharge is calculated as the arithmetic mean measurement of the pollutant over the day.

Median

Middle measurement in a set of data. The median of a set of data is found by first arranging the measurements in order of magnitude (either increasing or decreasing order). If the number of measurements (n) is odd, then the median = $X_{(n+1)/2}$. If n is even, then the median = $(X_{n/2} + X_{(n/2)+1})/2$ (i.e., the midpoint between n/2 and n/2+1).

Method Detection Limit (MDL)

Minimum concentration of a substance that can be measured and reported with 99 percent confidence that the analyte concentration is greater than zero, as defined in 40 C.F.R. part 136, Attachment B, revised as of July 3, 1999.

Minimum Level (ML)

Concentration at which the entire analytical system gives a recognizable signal and acceptable calibration point. The ML is the concentration in a sample that is equivalent to the concentration of the lowest calibration standard analyzed by a specific analytical procedure, assuming that all the method specified sample weights, volumes, and processing steps have been followed.

Mixing Zone

Limited volume of receiving water allocated for mixing with a wastewater discharge where water quality criteria can be exceeded without causing adverse effects to the overall water body.

Not Detected (ND)

Sample results less than the laboratory's MDL.

Persistent Pollutants

Substances for which degradation or decomposition in the environment is nonexistent or very slow.

Pollutant Minimization Program

Program of waste minimization and pollution prevention actions that include, but are not limited to, product substitution, waste stream recycling, alternative waste management methods, and education of the public and businesses. The goal of the Pollutant Minimization Program is to reduce all potential sources of a priority pollutant through pollutant minimization (control) strategies, including pollution prevention measures as appropriate, to maintain the effluent concentration at or below the water quality-based effluent limitation. Pollution prevention measures may be particularly appropriate for persistent bioaccumulative priority pollutants where there is evidence that beneficial uses are being impacted. Cost effectiveness may be considered when establishing the requirements of a Pollutant Minimization Program. The completion and implementation of a Pollution Prevention Plan, if required pursuant to Water Code section 13263.3(d), is considered to fulfill Pollutant Minimization Program requirements.

Pollution Prevention

Any action that causes a net reduction in the use or generation of a hazardous substance or other pollutant that is discharged into water and includes, but is not limited to, input change, operational improvement, production process change, and product reformulation (as defined in Water Code section 13263.3). Pollution prevention does not include actions that merely shift a pollutant in wastewater from one environmental medium to another environmental medium, unless clear environmental benefits of such an approach are identified to the satisfaction of the State Water Board or Regional Water Board.

Reporting Level (RL)

ML (and its associated analytical method) chosen by the Discharger for reporting and compliance determination from the MLs included in this Order, including an additional factor if applicable as discussed herein. The MLs included in this Order correspond to approved analytical methods for reporting a sample result that are selected by the Regional Water Board either from SIP Appendix 4 in accordance with SIP section 2.4.2 or established in accordance with SIP section 2.4.3. The ML is based on the proper application of method-based analytical procedures for sample preparation and the absence of any matrix interferences. Other factors may be applied to the ML depending on the specific sample preparation steps employed. For example, the treatment typically applied in cases where there are matrix-effects is to dilute the sample or sample aliquot by a factor of ten. In such cases, this additional factor must be applied to the ML in the computation of the RL.

Source of Drinking Water

Any water designated as having a municipal or domestic supply (MUN) beneficial use.

Standard Deviation (σ)

Measure of variability calculated as follows:

$$\sigma = \left(\frac{\sum[(x - \mu)^2]}{(n - 1)} \right)^{0.5}$$

where:

x is the observed value;

μ is the arithmetic mean of the observed values; and

n is the number of samples.

Toxicity Reduction Evaluation (TRE)

Study conducted in a step-wise process designed to identify the causative agents of effluent or ambient toxicity, isolate the sources of toxicity, evaluate the effectiveness of toxicity control options, and then confirm the reduction in toxicity. The first steps of the TRE consist of the collection of data relevant to the toxicity, including additional toxicity testing, and an evaluation of facility operations and maintenance practices, and best management practices. A Toxicity Identification Evaluation (TIE) may be required as part of the TRE, if appropriate. A TIE is a set of procedures to identify the specific chemicals responsible for toxicity. These procedures are performed in three phases (characterization, identification, and confirmation) using aquatic organism toxicity tests.

ATTACHMENT B – FACILITY MAP

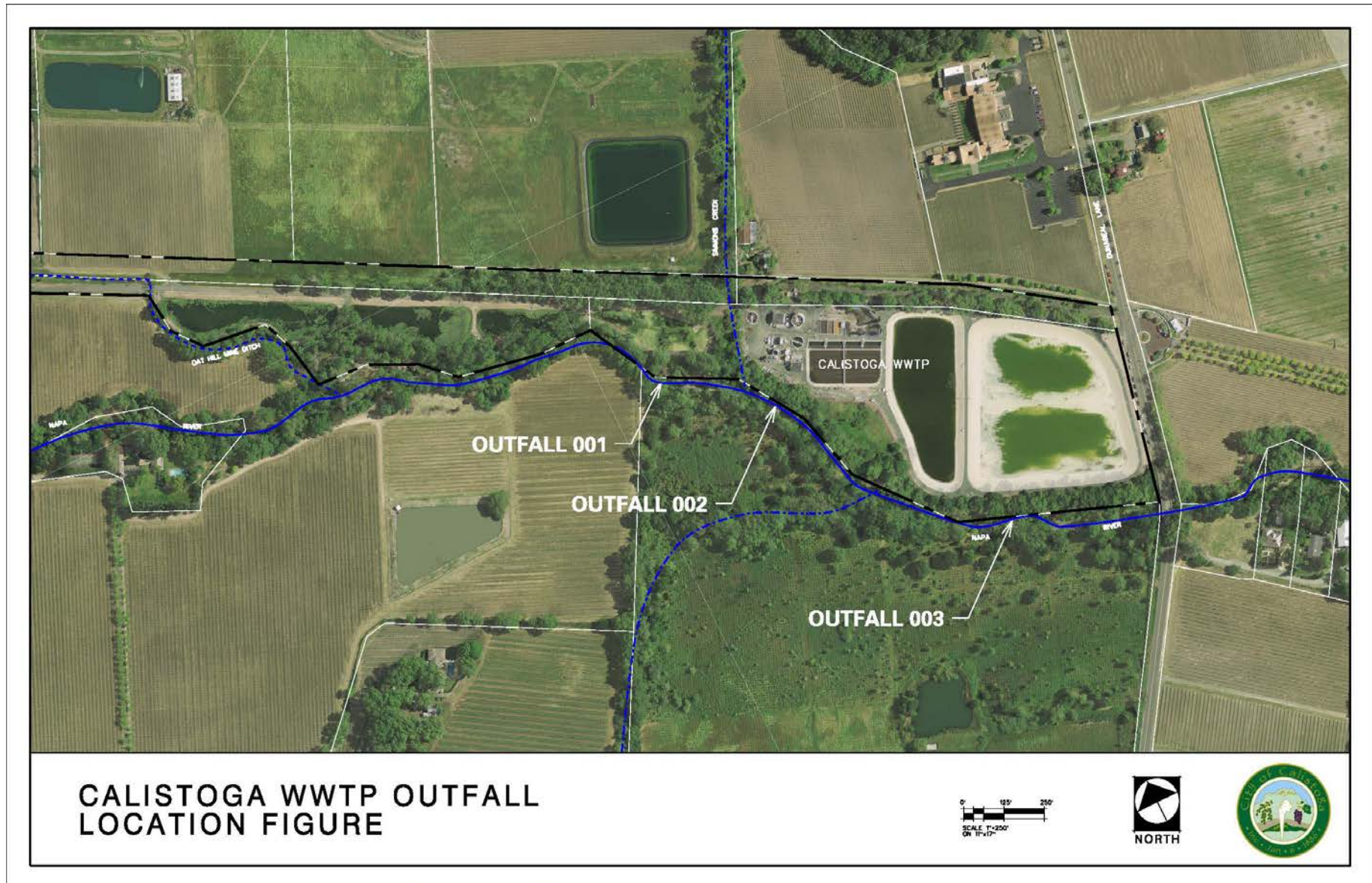

ATTACHMENT C – PROCESS FLOW DIAGRAM

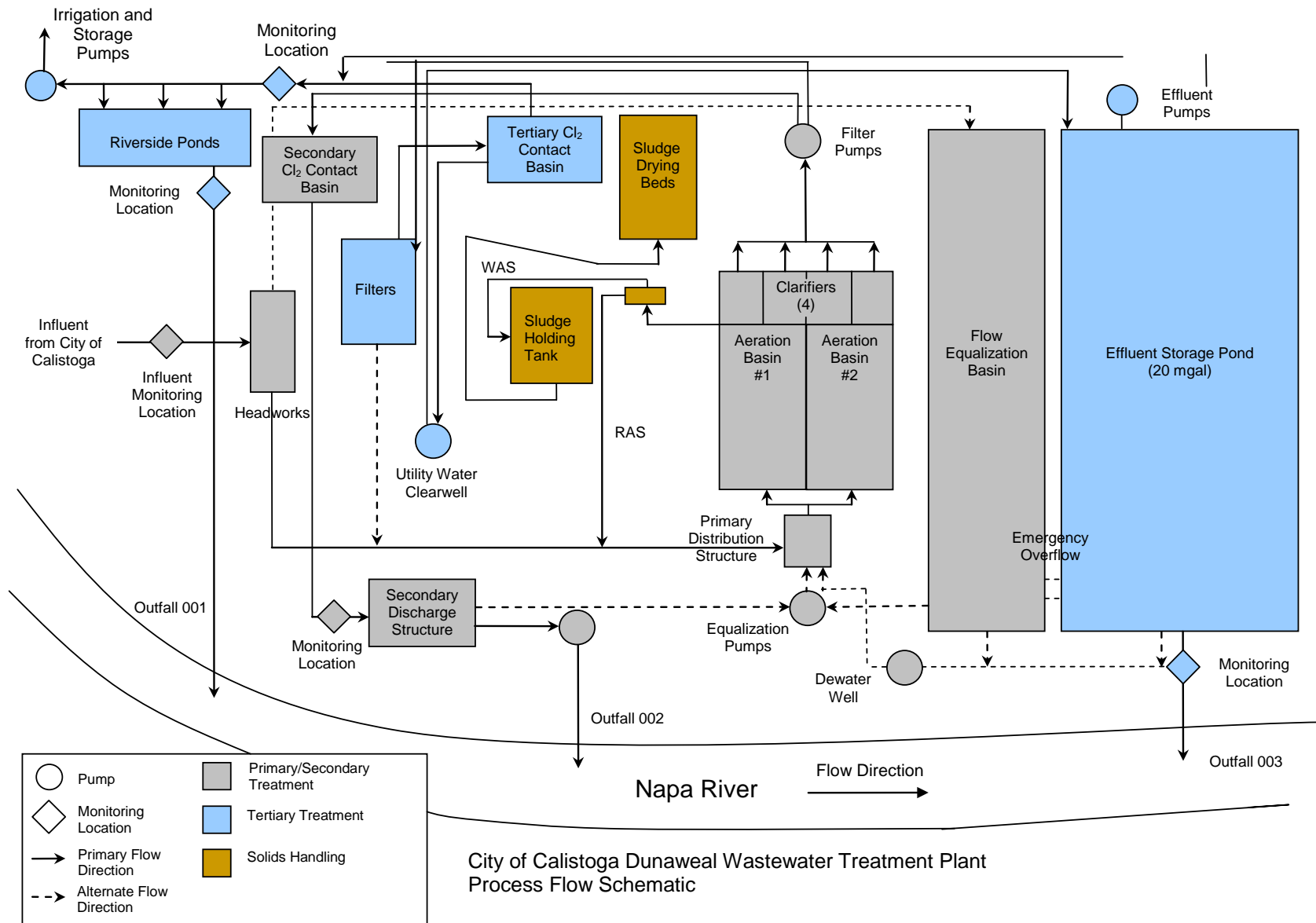

ATTACHMENT D –STANDARD PROVISIONS

I. STANDARD PROVISIONS – PERMIT COMPLIANCE

A. Duty to Comply

1. The Discharger must comply with all of the terms, requirements, and conditions of this Order. Any noncompliance constitutes a violation of the Clean Water Act (CWA) and the California Water Code and is grounds for enforcement action; permit termination, revocation and reissuance, or modification; denial of a permit renewal application; or a combination thereof. (40 C.F.R. § 122.41(a); Wat. Code §§ 13261, 13263, 13265, 13268, 13000, 13001, 13304, 13350, 13385.)
2. The Discharger shall comply with effluent standards or prohibitions established under CWA section 307(a) for toxic pollutants and with standards for sewage sludge use or disposal established under CWA section 405(d) within the time provided in the regulations that establish these standards or prohibitions, even if this Order has not yet been modified to incorporate the requirement. (40 C.F.R. § 122.41(a)(1).)

B. Need to Halt or Reduce Activity Not a Defense

It shall not be a defense for a Discharger in an enforcement action that it would have been necessary to halt or reduce the permitted activity in order to maintain compliance with the conditions of this Order. (40 C.F.R. § 122.41(c).)

C. Duty to Mitigate

The Discharger shall take all reasonable steps to minimize or prevent any discharge or sludge use or disposal in violation of this Order that has a reasonable likelihood of adversely affecting human health or the environment. (40 C.F.R. § 122.41(d).)

D. Proper Operation and Maintenance

The Discharger shall at all times properly operate and maintain all facilities and systems of treatment and control (and related appurtenances) which are installed or used by the Discharger to achieve compliance with the conditions of this Order. Proper operation and maintenance also includes adequate laboratory controls and appropriate quality assurance procedures. This provision requires the operation of backup or auxiliary facilities or similar systems that are installed by a Discharger only when necessary to achieve compliance with the conditions of this Order. (40 C.F.R. § 122.41(e).)

E. Property Rights

1. This Order does not convey any property rights of any sort or any exclusive privileges. (40 C.F.R. § 122.41(g).)
2. The issuance of this Order does not authorize any injury to persons or property or invasion of other private rights, or any infringement of state or local law or regulations. (40 C.F.R. § 122.5(c).)

F. Inspection and Entry

The Discharger shall allow the Regional Water Board, State Water Board, U.S. EPA, and/or their authorized representatives (including an authorized contractor acting as their representative), upon the presentation of credentials and other documents, as may be required by law, to (33 U.S.C. § 1318(a)(4)(B); 40 C.F.R. § 122.41(i); Wat. Code, §§ 13267, 13383):

1. Enter upon the Discharger's premises where a regulated facility or activity is located or conducted, or where records are kept under the conditions of this Order (33 U.S.C. § 1318(a)(4)(B)(i); 40 C.F.R. § 122.41(i)(1); Wat. Code, §§ 13267, 13383);
2. Have access to and copy, at reasonable times, any records that must be kept under the conditions of this Order (33 U.S.C. § 1318(a)(4)(B)(ii); 40 C.F.R. § 122.41(i)(2)); Wat. Code, §§ 13267, 13383);
3. Inspect and photograph, at reasonable times, any facilities, equipment (including monitoring and control equipment), practices, or operations regulated or required under this Order (33 U.S.C. § 1318(a)(4)(B)(ii); 40 C.F.R. § 122.41(i)(3); Wat. Code, §§ 13267, 13383); and
4. Sample or monitor, at reasonable times, for the purposes of ensuring Order compliance or as otherwise authorized by the CWA or the Water Code, any substances or parameters at any location. (33 U.S.C. § 1318(a)(4)(B); 40 C.F.R. § 122.41(i)(4); Wat. Code, §§ 13267, 13383.)

G. Bypass

1. Definitions

- a. “Bypass” means the intentional diversion of waste streams from any portion of a treatment facility. (40 C.F.R. § 122.41(m)(1)(i).)
- b. “Severe property damage” means substantial physical damage to property, damage to the treatment facilities, which causes them to become inoperable, or substantial and permanent loss of natural resources that can reasonably be expected to occur in the absence of a bypass. Severe property damage does not mean economic loss caused by delays in production. (40 C.F.R. § 122.41(m)(1)(ii).)

2. **Bypass not exceeding limitations.** The Discharger may allow any bypass to occur which does not cause exceedances of effluent limitations, but only if it is for essential maintenance to assure efficient operation. These bypasses are not subject to the provisions listed in Standard Provisions – Permit Compliance I.G.3, I.G.4, and I.G.5 below. (40 C.F.R. § 122.41(m)(2).)
3. **Prohibition of bypass.** Bypass is prohibited, and the Regional Water Board may take enforcement action against a Discharger for bypass, unless (40 C.F.R. § 122.41(m)(4)(i)):
 - a. Bypass was unavoidable to prevent loss of life, personal injury, or severe property damage (40 C.F.R. § 122.41(m)(4)(i)(A));

- b. There were no feasible alternatives to the bypass, such as the use of auxiliary treatment facilities, retention of untreated wastes, or maintenance during normal periods of equipment downtime. This condition is not satisfied if adequate back-up equipment should have been installed in the exercise of reasonable engineering judgment to prevent a bypass that occurred during normal periods of equipment downtime or preventive maintenance (40 C.F.R. § 122.41(m)(4)(i)(B)); and
 - c. The Discharger submitted notice to the Regional Water Board as required under Standard Provisions – Permit Compliance I.G.5 below. (40 C.F.R. § 122.41(m)(4)(i)(C).)
4. **Approval.** The Regional Water Board may approve an anticipated bypass, after considering its adverse effects, if the Regional Water Board determines that it will meet the three conditions listed in Standard Provisions—Permit Compliance I.G.3 above. (40 C.F.R. § 122.41(m)(4)(ii).)

5. Notice

- a. **Anticipated bypass.** If the Discharger knows in advance of the need for a bypass, it shall submit a notice, if possible at least 10 days before the date of the bypass. (40 C.F.R. § 122.41(m)(3)(i).)
- b. **Unanticipated bypass.** The Discharger shall submit notice of an unanticipated bypass as required in Standard Provisions - Reporting V.E below (24-hour notice). (40 C.F.R. § 122.41(m)(3)(ii).)

H. Upset

Upset means an exceptional incident in which there is unintentional and temporary noncompliance with technology based permit effluent limitations because of factors beyond the reasonable control of the Discharger. An upset does not include noncompliance to the extent caused by operational error, improperly designed treatment facilities, inadequate treatment facilities, lack of preventive maintenance, or careless or improper operation. (40 C.F.R. § 122.41(n)(1).)

- 1. **Effect of an upset.** An upset constitutes an affirmative defense to an action brought for noncompliance with such technology based permit effluent limitations if the requirements of Standard Provisions – Permit Compliance I.H.2 below are met. No determination made during administrative review of claims that noncompliance was caused by upset, and before an action for noncompliance, is final administrative action subject to judicial review. (40 C.F.R. § 122.41(n)(2).)
- 2. **Conditions necessary for a demonstration of upset.** A Discharger who wishes to establish the affirmative defense of upset shall demonstrate, through properly signed, contemporaneous operating logs or other relevant evidence that (40 C.F.R. § 122.41(n)(3)):
 - a. An upset occurred and that the Discharger can identify the cause(s) of the upset (40 C.F.R. § 122.41(n)(3)(i));
 - b. The permitted facility was, at the time, being properly operated (40 C.F.R. § 122.41(n)(3)(ii));

- c. The Discharger submitted notice of the upset as required in Standard Provisions—Reporting V.E.2.b below (24-hour notice) (40 C.F.R. § 122.41(n)(3)(iii)); and
 - d. The Discharger complied with any remedial measures required under Standard Provisions—Permit Compliance I.C above. (40 C.F.R. § 122.41(n)(3)(iv).)
3. **Burden of proof.** In any enforcement proceeding, the Discharger seeking to establish the occurrence of an upset has the burden of proof. (40 C.F.R. § 122.41(n)(4).)

II. STANDARD PROVISIONS—PERMIT ACTION

A. General

This Order may be modified, revoked and reissued, or terminated for cause. The filing of a request by the Discharger for modification, revocation and reissuance, or termination, or a notification of planned changes or anticipated noncompliance does not stay any Order condition. (40 C.F.R. § 122.41(f).)

B. Duty to Reapply

If the Discharger wishes to continue an activity regulated by this Order after the expiration date of this Order, the Discharger must apply for and obtain a new permit. (40 C.F.R. § 122.41(b).)

C. Transfers

This Order is not transferable to any person except after notice to the Regional Water Board. The Regional Water Board may require modification or revocation and reissuance of this Order to change the name of the Discharger and incorporate such other requirements as may be necessary under the CWA and the Water Code. (40 C.F.R. §§ 122.41(l)(3), 122.61.)

III. STANDARD PROVISIONS – MONITORING

- A. Samples and measurements taken for the purpose of monitoring shall be representative of the monitored activity. (40 C.F.R. § 122.41(j)(1).)
- B. Monitoring must be conducted according to test procedures approved under 40 C.F.R. part 136 for the analyses of pollutants unless another method is required under 40 C.F.R. subchapters N or O. Monitoring must be conducted according to sufficiently sensitive test methods approved under 40 C.F.R. part 136 for the analysis of pollutants or pollutant parameters or required under 40 C.F.R. chapter 1, subchapter N or O. For the purposes of this paragraph, a method is sufficiently sensitive when:
 1. The method minimum level (ML) is at or below the level of the effluent limitation established in the permit for the measured pollutant or pollutant parameter, and either (a) the method ML is at or below the level of the applicable water quality criterion for the measured pollutant or pollutant parameter, or (b) the method ML is above the applicable water quality criterion but the amount of the pollutant or pollutant parameter in a facility's discharge is high enough that the method detects and quantifies the level of the pollutant or pollutant parameter in the discharge; or

2. The method has the lowest ML of the analytical methods approved under 40 C.F.R. part 136 or required under 40 C.F.R. chapter 1, subchapter N or O for the measured pollutant or pollutant parameter.

In the case of pollutants for which there are no approved methods under 40 C.F.R. part 136 or otherwise required under 40 C.F.R. subchapters N or O, monitoring must be conducted according to a test procedure specified in this Order for such pollutants. (40 C.F.R. §§ 122.21(e)(3), 122.41(j)(4), 122.44(i)(1)(iv).)

IV. STANDARD PROVISIONS—RECORDS

- A. Except for records of monitoring information required by this Order related to the Discharger's sewage sludge use and disposal activities, which shall be retained for a period of at least five years (or longer as required by 40 C.F.R. part 503), the Discharger shall retain records of all monitoring information, including all calibration and maintenance records and all original strip chart recordings for continuous monitoring instrumentation, copies of all reports required by this Order, and records of all data used to complete the application for this Order, for a period of at least three (3) years from the date of the sample, measurement, report or application. This period may be extended by request of the Regional Water Board Executive Officer at any time. (40 C.F.R. § 122.41(j)(2).)
- B. Records of monitoring information shall include the following:
 1. The date, exact place, and time of sampling or measurements (40 C.F.R. § 122.41(j)(3)(i));
 2. The individual(s) who performed the sampling or measurements (40 C.F.R. § 122.41(j)(3)(ii));
 3. The date(s) the analyses were performed (40 C.F.R. § 122.41(j)(3)(iii));
 4. The individual(s) who performed the analyses (40 C.F.R. § 122.41(j)(3)(iv));
 5. The analytical techniques or methods used (40 C.F.R. § 122.41(j)(3)(v)); and
 6. The results of such analyses. (40 C.F.R. § 122.41(j)(3)(vi).)
- C. Claims of confidentiality for the following information will be denied (40 C.F.R. § 122.7(b)):
 1. The name and address of any permit applicant or Discharger (40 C.F.R. § 122.7(b)(1)); and
 2. Permit applications and attachments, permits, and effluent data. (40 C.F.R. § 122.7(b)(2).)

V. STANDARD PROVISIONS—REPORTING

A. Duty to Provide Information

The Discharger shall furnish to the Regional Water Board, State Water Board, or U.S. EPA within a reasonable time, any information which the Regional Water Board, State Water Board, or U.S. EPA may request to determine whether cause exists for modifying, revoking and reissuing, or terminating this Order or to determine compliance with this Order. Upon request, the Discharger shall also furnish to the Regional Water Board, State Water Board, or U.S. EPA copies of records required to be kept by this Order. (40 C.F.R. § 122.41(h); Wat. Code, §§ 13267, 13383.)

B. Signatory and Certification Requirements

1. All applications, reports, or information submitted to the Regional Water Board, State Water Board, and/or U.S. EPA shall be signed and certified in accordance with Standard Provisions—Reporting V.B.2, V.B.3, V.B.4, and V.B.5 below. (40 C.F.R. § 122.41(k).)
2. For a corporation, all permit applications shall be signed by a responsible corporate officer. For the purpose of this section, a responsible corporate officer means: (i) a president, secretary, treasurer, or vice-president of the corporation in charge of a principal business function, or any other person who performs similar policy- or decision-making functions for the corporation, or (ii) the manager of one or more manufacturing, production, or operating facilities, provided, the manager is authorized to make management decisions which govern the operation of the regulated facility including having the explicit or implicit duty of making major capital investment recommendations, and initiating and directing other comprehensive measures to assure long term environmental compliance with environmental laws and regulations; the manager can ensure that the necessary systems are established or actions taken to gather complete and accurate information for permit application requirements; and where authority to sign documents has been assigned or delegated to the manager in accordance with corporate procedures. (40 C.F.R. § 122.22(a)(1).)

For a partnership or sole proprietorship, all permit applications shall be signed by a general partner or the proprietor, respectively. (40 C.F.R. § 122.22(a)(2).)

For a municipality, state, federal, or other public agency, all permit applications shall be signed by either a principal executive officer or ranking elected official. For purposes of this provision, a principal executive officer of a federal agency includes (i) the chief executive officer of the agency, or (ii) a senior executive officer having responsibility for the overall operations of a principal geographic unit of the agency (e.g., Regional Administrators of U.S. EPA). (40 C.F.R. § 122.22(a)(3).)

3. All reports required by this Order and other information requested by the Regional Water Board, State Water Board, or U.S. EPA shall be signed by a person described in Standard Provisions – Reporting V.B.2 above, or by a duly authorized representative of that person. A person is a duly authorized representative only if:
 - a. The authorization is made in writing by a person described in Standard Provisions—Reporting V.B.2 above (40 C.F.R. § 122.22(b)(1));
 - b. The authorization specifies either an individual or a position having responsibility for the overall operation of the regulated facility or activity such as the position of plant manager, operator of a well or a well field, superintendent, position of equivalent responsibility, or an individual or position having overall responsibility for environmental matters for the company. (A duly authorized representative may thus be either a named individual or any individual occupying a named position.) (40 C.F.R. § 122.22(b)(2)); and
 - c. The written authorization is submitted to the Regional Water Board and State Water Board. (40 C.F.R. § 122.22(b)(3).)

4. If an authorization under Standard Provisions – Reporting V.B.3 above is no longer accurate because a different individual or position has responsibility for the overall operation of the facility, a new authorization satisfying the requirements of Standard Provisions—Reporting V.B.3 above must be submitted to the Regional Water Board and State Water Board prior to or together with any reports, information, or applications, to be signed by an authorized representative. (40 C.F.R. § 122.22(c).)
5. Any person signing a document under Standard Provisions—Reporting V.B.2 or V.B.3 above shall make the following certification:

“I certify under penalty of law that this document and all attachments were prepared under my direction or supervision in accordance with a system designed to assure that qualified personnel properly gather and evaluate the information submitted. Based on my inquiry of the person or persons who manage the system or those persons directly responsible for gathering the information, the information submitted is, to the best of my knowledge and belief, true, accurate, and complete. I am aware that there are significant penalties for submitting false information, including the possibility of fine and imprisonment for knowing violations.” (40 C.F.R. § 122.22(d).)

C. Monitoring Reports

1. Monitoring results shall be reported at the intervals specified in the Monitoring and Reporting Program in this Order. (40 C.F.R. § 122.22(l)(4).)
2. Monitoring results must be reported on a Discharge Monitoring Report (DMR) form or forms provided or specified by the Regional Water Board or State Water Board for reporting results of monitoring of sludge use or disposal practices. (40 C.F.R. § 122.41(l)(4)(i).)
3. If the Discharger monitors any pollutant more frequently than required by this Order using test procedures approved under 40 C.F.R. part 136, or another method required for an industry-specific waste stream under 40 C.F.R. chapter 1, subchapters N or O, the results of such monitoring shall be included in the calculation and reporting of the data submitted in the DMR or sludge reporting form specified by the Regional Water Board. (40 C.F.R. § 122.41(l)(4)(ii).)
4. Calculations for all limitations, which require averaging of measurements, shall utilize an arithmetic mean unless otherwise specified in this Order. (40 C.F.R. § 122.41(l)(4)(iii).)

D. Compliance Schedules

Reports of compliance or noncompliance with, or any progress reports on, interim and final requirements contained in any compliance schedule of this Order, shall be submitted no later than 14 days following each schedule date. (40 C.F.R. § 122.41(l)(5).)

E. Twenty-Four Hour Reporting

1. The Discharger shall report any noncompliance that may endanger health or the environment. Any information shall be provided orally within 24 hours from the time the Discharger becomes aware of the circumstances. A written submission shall also be provided within five (5) days of the time the Discharger becomes aware of the circumstances. The written

submission shall contain a description of the noncompliance and its cause; the period of noncompliance, including exact dates and times, and if the noncompliance has not been corrected, the anticipated time it is expected to continue; and steps taken or planned to reduce, eliminate, and prevent reoccurrence of the noncompliance. (40 C.F.R. § 122.41(l)(6)(i).)

2. The following shall be included as information that must be reported within 24 hours under this paragraph (40 C.F.R. § 122.41(l)(6)(ii)):
 - a. Any unanticipated bypass that exceeds any effluent limitation in this Order. (40 C.F.R. § 122.41(l)(6)(ii)(A).)
 - b. Any upset that exceeds any effluent limitation in this Order. (40 C.F.R. § 122.41(l)(6)(ii)(B).)
3. The Regional Water Board may waive the above-required written report under this provision on a case-by-case basis if an oral report has been received within 24 hours. (40 C.F.R. § 122.41(l)(6)(iii).)

F. Planned Changes

The Discharger shall give notice to the Regional Water Board as soon as possible of any planned physical alterations or additions to the permitted facility. Notice is required under this provision only when (40 C.F.R. § 122.41(l)(1)):

1. The alteration or addition to a permitted facility may meet one of the criteria for determining whether a facility is a new source in 40 C.F.R. section 122.29(b) (40 C.F.R. § 122.41(l)(1)(i)); or
2. The alteration or addition could significantly change the nature or increase the quantity of pollutants discharged. This notification applies to pollutants that are not subject to effluent limitations in this Order. (Alternatively, for an existing manufacturing, commercial, mining, or silvicultural discharge as referenced in 40 C.F.R. section 122.42(a), this notification applies to pollutants that are subject neither to effluent limitations in this Order nor to notification requirements under 40 C.F.R. section 122.42(a)(1) (see Additional Provisions—Notification Levels VII.A.1).) (40 C.F.R. § 122.41(l)(1)(ii).)
3. The alteration or addition results in a significant change in the Discharger's sludge use or disposal practices, and such alteration, addition, or change may justify the application of permit conditions that are different from or absent in the existing permit, including notification of additional use or disposal sites not reported during the permit application process or not reported pursuant to an approved land application plan. (40 C.F.R. § 122.41(l)(1)(iii).)

G. Anticipated Noncompliance

The Discharger shall give advance notice to the Regional Water Board or State Water Board of any planned changes in the permitted facility or activity that may result in noncompliance with this Order's requirements. (40 C.F.R. § 122.41(l)(2).)

H. Other Noncompliance

The Discharger shall report all instances of noncompliance not reported under Standard Provisions—Reporting V.C, V.D, and V.E above at the time monitoring reports are submitted. The reports shall contain the information listed in Standard Provision—Reporting V.E above. (40 C.F.R. § 122.41(1)(7).)

I. Other Information

When the Discharger becomes aware that it failed to submit any relevant facts in a permit application, or submitted incorrect information in a permit application or in any report to the Regional Water Board, State Water Board, or U.S. EPA, the Discharger shall promptly submit such facts or information. (40 C.F.R. § 122.41(1)(8).)

VI. STANDARD PROVISIONS – ENFORCEMENT

- A. The Regional Water Board is authorized to enforce the terms of this permit under several provisions of the Water Code, including, but not limited to, sections 13268, 13385, 13386, and 13387.

VII. ADDITIONAL PROVISIONS—NOTIFICATION LEVELS

A. Publicly-Owned Treatment Works (POTWs)

All POTWs shall provide adequate notice to the Regional Water Board of the following (40 C.F.R. § 122.42(b)):

1. Any new introduction of pollutants into the POTW from an indirect discharger that would be subject to CWA sections 301 or 306 if it were directly discharging those pollutants (40 C.F.R. § 122.42(b)(1)); and
2. Any substantial change in the volume or character of pollutants being introduced into that POTW by a source introducing pollutants into the POTW at the time of adoption of this Order. (40 C.F.R. § 122.42(b)(2).)
3. Adequate notice shall include information on the quality and quantity of effluent introduced into the POTW as well as any anticipated impact of the change on the quantity or quality of effluent to be discharged from the POTW. (40 C.F.R. § 122.42(b)(3).)

ATTACHMENT E – MONITORING AND REPORTING PROGRAM (MRP)

Contents

I.	General Monitoring Provisions.....	E-2
II.	Monitoring Locations.....	E-2
III.	Influent Monitoring Requirements	E-3
IV.	Effluent Monitoring Requirements	E-4
	A. Discharges to Napa River.....	E-4
	B. Discharges to Irrigation Fields or Offsite Re-use.....	E-5
V.	Whole Effluent Toxicity Testing Requirements	E-5
	A. Whole Effluent Acute Toxicity	E-5
VI.	Receiving Water Monitoring Requirements	E-6
VII.	Other Monitoring Requirements	E-7
	A. Biosolids Monitoring.....	E-7
	B. Riverside Wastewater Pond Monitoring Requirements	E-7
	C. Rainfall	E-8
VIII.	Reporting Requirements	E-8
	A. General Monitoring and Reporting Requirements	E-8
	B. Self-Monitoring Reports.....	E-8
	C. Discharge Monitoring Reports (DMRs).....	E-11
IX.	Modifications to Attachment G	E-11

Tables

Table E-1.	Monitoring Locations.....	E-2
Table E-2.	Influent Monitoring.....	E-3
Table E-3.	Effluent Monitoring	E-4
Table E-4.	Receiving Water Monitoring	E-6
Table E-5.	Riverside Wastewater Pond Monitoring	E-7
Table E-6.	CIWQS Reporting.....	E-9
Table E-7.	Monitoring Periods	E-10

ATTACHMENT E – MONITORING AND REPORTING PROGRAM (MRP)

Clean Water Act section 308 and 40 C.F.R. sections 122.41(h), 122.41(j)-(l), 122.44(i), and 122.48 require that all National Pollutant Discharge Elimination System (NPDES) permits specify monitoring and reporting requirements. Water Code sections 13267 and 13383 also authorize the California Regional Water Quality Control Board, San Francisco Bay Region (Regional Water Board) to establish monitoring, inspection, entry, reporting, and recordkeeping requirements. This MRP establishes monitoring, reporting, and recordkeeping requirements that implement federal and State laws and regulations.

I. GENERAL MONITORING PROVISIONS

- A. The Discharger shall comply with this MRP. The Executive Officer may amend this MRP pursuant to 40 C.F.R. sections 122.62, 122.63, and 124.5. If any discrepancies exist between this MRP and the *Regional Standard Provisions, and Monitoring and Reporting Requirements (Supplement to Attachment D) for NPDES Wastewater Discharge Permits* (Attachment G), this MRP shall prevail.
- B. The Discharger shall conduct all monitoring in accordance with Attachment D, section III, as supplemented by Attachment G. Equivalent test methods must be more sensitive than those specified in 40 C.F.R. section 136 and must be specified in this permit.

II. MONITORING LOCATIONS

The Discharger shall establish the following monitoring locations to demonstrate compliance with the effluent limitations, discharge specifications, and other requirements in this Order:

Table E-1. Monitoring Locations

Sampling Location Type	Monitoring Location Name	Monitoring Location Description
Influent	INF-001	A point in the treatment facility headworks where all waste tributary to the treatment plant is present, but preceding any phase of treatment.
Effluent	EFF-001	A point following tertiary treatment (including treatment within the Riverside Ponds) where all waste tributary to Discharge Point No. 001 is present, but prior to discharge.
Effluent	EFF-002	A point following secondary treatment where all waste tributary to Discharge Point No. 002 is present, but prior to discharge.
Effluent	EFF-003	A point following tertiary treatment (except treatment within the Riverside Ponds) where all waste tributary to Discharge Point No. 003 is present, but prior to discharge.
Effluent	REC-001 (formerly EFF-003)	A point after full treatment, including disinfection, that represents all wastewater directed to irrigation fields or recycled (excluding internal recycle at the treatment plant), and thus not discharged to the Napa River at Discharge Point Nos. 001, 002, or 003.
Receiving Water	RSW-001	A point in the Napa River about 1,000 feet upstream from Discharge Point No. 001.
Receiving Water	RSW-002	A point in the Napa River about 100 feet upstream from Discharge Point No. 001.
Receiving Water	RSW-004	A point in the Napa River about 100 feet downstream from Discharge Point No. 001.
Receiving Water	RSW-005	A point in the Napa River about 100 feet downstream from Discharge Point No. 002.

Sampling Location Type	Monitoring Location Name	Monitoring Location Description
Receiving Water	RSW-006 ^[1]	A point in the Napa River about 1,000 feet downstream from Discharge Point No. 002.
Receiving Water	RSW-007	A point in the Napa River approximately 1,200 feet downstream from Discharge Point No. 002 (approximately 370 feet downstream from Discharge Point No. 003), at the Dunaweal Bridge.
Receiving Water	RSW-008 ^[1]	A point in the Napa River about 1,000 feet downstream from Discharge Point No. 003.
Receiving Water	RSW-900	Any point or points in the Napa River for the purpose of collecting data for the Receiving Water Characterization Study identified in Provision VI.C.3 of the Order.
Biosolids	BIO-001	Biosolids.
Pond Water	PON-001 through PON-004	Points along the perimeters of the four Riverside Ponds.

Footnote:

^[1] Monitoring at Monitoring Location RSW-006 is required unless Discharge Point No. 003 is constructed and authorized pursuant to Provision VI.C.8 of the Order. If Discharge Point No. 003 is constructed and authorized pursuant to Provision VI.C.8 of the Order, monitoring at Monitoring Location RSW-008 is required instead.

III. INFLUENT MONITORING REQUIREMENTS

The Discharger shall monitor plant influent at Monitoring Location INF-001 as follows:

Table E-2. Influent Monitoring

Parameter	Units	Sample Type	Minimum Sampling Frequency
Flow ^[1]	MGD	Continuous	1/Day
Biochemical Oxygen Demand, 5-day @ 20°C (BOD ₅)	mg/L	C-24	1/Week ^[2]
Total Suspended Solids (TSS)	mg/L	C-24	1/Week ^[2]

Unit Abbreviations:

MGD = million gallons per day
 mg/L = milligrams per liter
 kg/day = kilograms per day

Sample Types:

Continuous = measured continuously
 C-24 = 24-hour composite sample

Sampling Frequencies:

1/Day = once per day
 1/Week = once per week

Footnote:

^[1] Flow shall be monitored continuously and the following information shall be reported in monthly self-monitoring reports:

- Daily average flow (MGD)
- Monthly average flow (MGD)
- Total monthly flow volume (MG)
- Maximum and minimum daily average flow rates (MGD)

^[2] The Discharger shall collect influent samples on the same days as effluent samples. The monitoring frequency may be decreased to once per quarter when not discharging to the Napa River.

IV. EFFLUENT MONITORING REQUIREMENTS

A. Discharges to Napa River

When discharging to the Napa River, the Discharger shall monitor plant effluent at Monitoring Locations EFF-001, EFF-002, and EFF-003 as follows. When the minimum sampling frequency is weekly, monthly, or quarterly, at least one sample is required for any weekly, monthly, or quarterly period in which a discharge occurs.

Table E-3. Effluent Monitoring

Parameter	Units	Sample Type	Minimum Sampling Frequency
Flow ^[1]	MGD	Continuous	Continuous/D
BOD ₅	mg/L	C-24	1/Week
TSS	mg/L	C-24	1/Week
Oil and Grease	mg/L	Grab ^[2]	1/Month
pH	standard units	Continuous	Continuous/D ^{[3] [4]}
Temperature	°C	Grab	1/Day ^[4]
Turbidity ^[5]	NTU	Grab	1/Day ^[5]
Total Coliform Bacteria ^[6]	MPN/100 mL	Grab	3/Week
Acute Toxicity ^[7]	% Survival	C-24	1/Month
Chronic Toxicity ^[8]	TUc	C-24	1/Year
Chlorine Residual	mg/L	Continuous/2H ^[9]	1/2H
Antimony, Total Recoverable	µg/L	C-24	1/Month
Boron, Total Recoverable	µg/L	C-24	1/Month
Cyanide, Total Recoverable	µg/L	C-24	1/Month
Copper, Total Recoverable	µg/L	C-24	1/Month
Chlorodibromomethane	µg/L	C-24	1/Month
Dichlorobromomethane	µg/L	C-24	1/Month
Ammonia, Total	mg/L as N	Grab	1/Month ^[4]
Standard Observations ^[10]	---	---	1/Week
River Flow-to-Effluent Ratio ^[11]	---	Calculated	1/Day

Unit Abbreviations:

- °C = degrees Celsius
- kg/day = kilograms per day
- µg/L = micrograms per liter
- mg/L = milligrams per liter
- mg/L as N = milligrams per liter as nitrogen
- MGD = million gallons per day
- MPN/100 mL = most probable number per 100 milliliters
- NTU = nephelometric turbidity units
- % Removal = percent removal
- % Saturation = percent oxygen saturation
- % Survival = percent survival
- TUc = chronic toxicity units, equal to 100/NOEL, where NOEL = IC₂₅, EC₂₅, or NOEC

Sample Types:

- C-24 = 24 hour composite
- Continuous = measured continuously
- Continuous/2H= measured continuously or, if infeasible, at least every 2 hours via grab samples
- Grab = grab sample

Sampling Frequencies:

Continuous/D = measured continuously, and recorded and reported daily

- 1/2H = once per two hours
- 1/Day = once per day
- 1/Week = once per week
- 3/Week = twice per week
- 1/Month = once per month
- 1/Quarter = once per quarter
- 1/Year = once per year

Footnotes:

- [1] Flow shall be monitored continuously and the following information shall be reported in monthly self-monitoring reports:
 - Daily average flow (MGD)
 - Monthly average flow (MGD)
 - Total monthly flow volume (MG)
 - Maximum and minimum daily average flow rates (MGD)
- [2] Each oil and grease sampling and analysis event shall be conducted in accordance with U.S. EPA Method 1664A.
- [3] If pH is monitored continuously, the minimum and maximum values for each day shall be reported in self-monitoring reports.
- [4] Ammonia shall be monitored concurrently with pH and temperature.
- [5] Required only at Monitoring Locations EFF-001 and EFF-003.
- [6] Results may be reported as Colony Forming Units/100 milliliters (CFU/100 mL) if the laboratory method used provides results in CFU/100 mL.
- [7] Acute bioassay tests shall be performed in accordance with MRP section V.A.
- [8] Critical life stage toxicity tests shall be performed and reported in accordance with MRP section V.B at the frequency specified above.
- [9] Effluent residual chlorine concentrations shall be monitored once per day by grab sample from the recycled water storage pond, or continuously, or at a minimum every other hour, immediately following dechlorination. The Discharger shall describe all excursions of the chlorine limit in the transmittal letter of self-monitoring reports as required by Attachment G section V.C.1.a. If monitoring continuously, the Discharger shall report through data upload to CIWQS, from discrete readings of the continuous monitoring every hour on the hour, the maximum for each day and any other discrete hourly reading that exceed the effluent limit, and, for the purpose of mandatory minimum penalties required by Water Code section 13385(i), compliance shall be based only on these discrete readings. The Discharger shall retain continuous monitoring readings for at least three years. The Regional Water Board reserves the right to use all continuous monitoring data for discretionary enforcement.
- [10] Standard observations are specified in Attachment G section III.C.
- [11] The Discharger shall calculate and report the river flow-to-effluent ratio once per day whenever discharging to the Napa River. The river flow-to-effluent ratio shall be calculated as the ratio of the instantaneous flow of the Napa River measured at Monitoring Location RSW-007 (on or before 9 a.m. every morning) to the effluent flow during the previous 24 hours (9 a.m. to 9 a.m.) measured at Monitoring Locations EFF-001, EFF-002, and EFF-003. If real-time river flow monitoring is established, the Discharger shall calculate the river flow-to-effluent flow ratio at least once per hour when discharging and report the results in its self-monitoring reports.

B. Discharges to Irrigation Fields or Offsite Re-use

The Discharger shall monitor plant effluent flow at Monitoring Location REC-001 continuously and report the following information:

- Daily average flow (MGD)
- Total monthly flow volume (MG)

V. WHOLE EFFLUENT TOXICITY TESTING REQUIREMENTS

A. Whole Effluent Acute Toxicity

1. Compliance with the acute toxicity effluent limitations at Discharge Point Nos. 001, 002, and 003 shall be evaluated at Monitoring Locations EFF-001, EFF-002, and EFF-003 by measuring survival of test organisms exposed to 96-hour static renewal bioassays.

2. Test organisms shall be fathead minnow (*Pimephales promelas*) or rainbow trout (*Oncorhynchus mykiss*). Alternatively, the Executive Officer may specify a more sensitive organism or, if testing a particular organism proves unworkable, the most sensitive organism available.
3. All bioassays shall be performed according to the most up-to-date protocols in 40 C.F.R. part 136, currently *Methods for Measuring the Acute Toxicity of Effluents and Receiving Water to Freshwater and Marine Organisms*, 5th Edition (EPA-821-R-02-012). If these protocols prove unworkable, the Executive Officer and the Environmental Laboratory Accreditation Program may grant exceptions in writing upon the Discharger’s request with justification.
4. If the Discharger demonstrates that specific identifiable substances in the discharge are rapidly rendered harmless upon discharge to the receiving water, compliance with the acute toxicity limit may be determined after test samples are adjusted to remove the influence of those substances. Written acknowledgement that the Executive Officer concurs with the Discharger’s demonstration and that the adjustment will not remove the influence of other substances must be obtained prior to any such adjustment. The Discharger may manually adjust the pH of whole effluent acute toxicity samples prior to performing bioassays to minimize ammonia toxicity interference.
5. The sample may be taken from final secondary effluent prior to disinfection. Bioassay water shall be monitored daily for pH, dissolved oxygen, ammonia (if toxicity is observed), temperature, hardness, and alkalinity. These results shall be reported. If final or intermediate results of an acute bioassay test indicate a violation or threatened violation (e.g., the percentage of surviving test organisms is less than 70 percent), the Discharger shall initiate a new test as soon as practical and shall investigate the cause of the mortalities and report its findings in the next self-monitoring report. The Discharger shall repeat the test until a test fish survival rate of 90 percent or greater is observed. If the control fish survival rate is less than 90 percent, the bioassay test shall be restarted with new fish and shall continue as soon as practical until an acceptable test is completed (i.e., control fish survival rate is 90 percent or greater).

VI. RECEIVING WATER MONITORING REQUIREMENTS

When discharging to the Napa River, the Discharger shall monitor the Napa River at Monitoring Locations RSW-001 through RSW-008 as follows (see Table E-4 footnote 1 below):

Table E-4. Receiving Water Monitoring

Parameter	Units	Sample Type	Minimum Sampling Frequency ^[1]
Flow	MGD	---	1/Day
pH	standard units	Grab	1/Quarter
Temperature	°C	Grab	1/Quarter
Dissolved Oxygen	mg/L	Grab	1/Quarter
	% Saturation	Grab	1/Quarter
Antimony	µg/L	Grab	1/Quarter
Boron	mg/L	Grab	1/Quarter

Parameter	Units	Sample Type	Minimum Sampling Frequency ^[1]
Copper	µg/L	Grab	1/Quarter
Total Ammonia	mg/L as N	Grab	1/Quarter
Hardness	mg/L as CaCO ₃	Grab	1/Quarter
Salinity or Total Dissolved Solids	ppt or mg/L	Grab	1/Quarter
Standard Observations ^[2]	---	Observations	1/Week

Unit Abbreviations:

- °C = degrees Celsius
- µmhos = micromhos
- mg/L = milligrams per liter
- mg/L as CaCO₃ = milligrams per liter as calcium carbonate
- mg/L as N = milligrams per liter as nitrogen
- mg/L as P = milligrams per liter as phosphorous
- MGD = million gallons per day
- NTU = nephelometric turbidity units
- ppt = parts per trillion
- % Saturation = percent saturation

Sample Types:

Grab = grab sample

Sampling Frequencies:

- Continuous/D = measured continuously, and recorded and reported daily
- 1/Day = once per day
- 1/Week = once per week
- 1/Month = once per month

Footnotes:

- ^[1] Until Discharge Point No. 003 is constructed and authorized pursuant to Provision VI.C.8 of the Order, only flow monitoring is required at Monitoring Location RSW-007; monitoring for all other parameters is required at all other monitoring locations (however, monitoring at Monitoring Location RSW-005 is only required when discharging at Discharge Point No. 002). When Discharge Point No. 003 is constructed and authorized pursuant to Provision VI.C.8 of the Order, monitoring is no longer required at Monitoring Location RSW-006; monitoring for all other parameters is required at all other monitoring locations, including Monitoring Location RSW-007 (monitoring at Monitoring Location RSW-005 is only required when discharging at Discharge Point No. 002).
- ^[2] Standard observations are specified in Attachment G section III.C.

VII. OTHER MONITORING REQUIREMENTS

A. Biosolids Monitoring

The Discharger shall adhere to sludge monitoring requirements required by 40 C.F.R. part 258 (for landfill disposal) or 40 C.F.R. section 503 (for land application).

B. Riverside Wastewater Pond Monitoring Requirements

The Discharger shall monitor the Riverside Ponds at Monitoring Locations PON-001 through PON-004 as follows:

Table E-5. Riverside Wastewater Pond Monitoring

Parameter ^[1]	Units	Sample Type	Minimum Sampling Frequency
Dissolved Oxygen	mg/L	Grab	2/Year
Dissolved Sulfide ^[1]	mg/L	Grab	2/Year
Standard Observations ^[2]	---	Observations	1/Month

Unit Abbreviations:

mg/L = milligrams per liter

Sample Types:

Grab = grab sample

Sampling Frequencies:

1/Month = once per month

2/Year = twice per year

Footnotes:

^[1] Only required if dissolved oxygen concentration is less than 2.0 mg/L.

^[2] Standard observations are specified in Attachment G section III.C.

C. Rainfall

The Discharger shall measure precipitation in inches and record plant rain gauge measurements daily.

VIII. REPORTING REQUIREMENTS

A. General Monitoring and Reporting Requirements

The Discharger shall comply with all Standard Provisions (Attachments D and G) related to monitoring, reporting, and recordkeeping, with modifications shown in section VIII, below.

B. Self-Monitoring Reports

1. **SMR Format.** The Discharger shall electronically submit SMRs using the State Water Board's California Integrated Water Quality System (CIWQS) Web site (http://www.waterboards.ca.gov/water_issues/programs/ciwqs). The CIWQS website will provide additional information for SMR submittal in the event of a planned service interruption for electronic submittal.
2. **SMR Due Dates and Contents.** The Discharger shall submit SMRs by the due dates, and with the contents, specified below:
 - a. **Monthly SMRs** — Monthly SMRs shall be due 30 days after the end of each calendar month, covering that calendar month. The monthly SMR shall contain the applicable items described in sections V.B and V.C of both Attachments D and G of this Order. See Provision VI.C.2 (Effluent Characterization Study and Report), Provision VI.C.3 (Receiving Water Characterization Study and Report), and Provision VI.C.4 (Pollutant Minimization Program) of this Order for information that must also be reported with monthly SMRs.

Monthly SMRs shall include all new monitoring results obtained since the last SMR was submitted. If the Discharger monitors any pollutant more frequently than required by this Order, the Discharger shall include the results of such monitoring in the calculations and reporting for the SMR.

- b. **Annual SMR** — Annual SMRs shall be due February 1 each year, covering the previous calendar year. The annual SMR shall contain the items described in sections V.C.1.f of Attachment G. See also Provisions VI.C.2 (Effluent Characterization Study and Report),

Provision VI.C.3 (Receiving Water Characterization Study and Report), Provision VI.C.4 (Pollutant Minimization Program), and VI.C.7.a (Sludge and Biosolids Management) of this Order for requirements to submit reports with the annual SMR.

3. Specifications for Submitting SMRs to CIWQS — The Discharger shall submit analytical results and other information using one of the following methods:

Table E-6. CIWQS Reporting

Parameter	Method of Reporting	
	EDF/CDF data upload or manual entry	Attached File
All parameters identified in influent, effluent, and receiving water monitoring tables (except Dissolved Oxygen and Temperature)	Required for all results	
Dissolved Oxygen Temperature	Required for monthly maximum and minimum results only ^[1]	Discharger may use this method for all results or keep records
Antimony Arsenic Beryllium Cadmium Chromium Copper Cyanide Lead Mercury Nickel Selenium	Silver Thallium Zinc Dioxins & Furans (by U.S. EPA Method 1613) Other Pollutants (by U.S. EPA methods 601, 602, 608, 610, 614, 624, and 625)	Required for all results ^[2]
Volume and Duration of Blended Discharge ^[3]	Required for all blended effluent discharges	
Analytical Method	Not required (Discharger may select “data unavailable”) ^[1]	
Collection Time Analysis Time	Not required (Discharger may select “0:00”) ^[1]	

Footnotes:

- ^[1] The Discharger shall continue to monitor at the minimum frequency specified in this MRP, keep records of the measurements, and make the records available upon request.
- ^[2] These parameters require EDF/CDF data upload or manual entry regardless of whether monitoring is required by this MRP or other provisions of this Order (except for biosolids, sludge, or ash provisions).
- ^[3] The requirement for volume and duration of blended discharge applies only if this Order authorizes the Discharger to discharge blended effluent.

The Discharger shall arrange all reported data in a tabular format and summarize data to clearly illustrate whether the Facility is operating in compliance with effluent limitations. The Discharger is not required to duplicate the submittal of data entered in a tabular format within CIWQS. When electronic submittal of data is required and CIWQS does not provide for entry into a tabular format, the Discharger shall electronically submit the data in a tabular format as an attachment.

4. Monitoring Periods. Monitoring periods for all required monitoring shall be as set forth below unless otherwise specified:

Table E-7. Monitoring Periods

Sampling Frequency	Monitoring Period Begins On...	Monitoring Period
Continuous	Order effective date	All times
1/2 Hours	Order effective date	Every two-hour period, beginning at midnight (e.g., 12:00 a.m. through 1:59 a.m.)
1/Day	Order Effective Date	Every 24-hour period, beginning at midnight and continuing through 11:59 p.m.
1/Week or 3/Week	First Sunday following or on Order effective date	Sunday through Saturday
1/Month	First day of calendar month following or on Order effective date	First day of calendar month through last day of calendar month
1/Quarter	Closest January 1, April 1, July 1, or October 1 following or on Order effective date	January 1 through March 31 April 1 through June 30 July 1 through September 30 October 1 through December 31
1/Year	Closest January 1 before or after Order effective date ^[1]	January 1 through December 31
2/Year	Closest May 1 or November 1 before or after Order effective date ^[1]	November 1 through April 30 May 1 through October 31
Once	Order effective date	Anytime such that monitoring results may be submitted with the application for permit reissuance

Footnote:

^[1] Monitoring performed during the previous order term may be used to satisfy monitoring required by this Order.

5. RL and MDL Reporting. The Discharger shall report with each sample result the Reporting Level (RL) and Method Detection Limit (MDL) as determined by the procedure in 40 C.F.R. part 136. The Discharger shall report the results of analytical determinations for the presence of chemical constituents in a sample using the following reporting protocols:

- a. Sample results greater than or equal to the RL shall be reported as measured by the laboratory (i.e., the measured chemical concentration in the sample).
- b. Sample results less than the RL, but greater than or equal to the laboratory’s MDL, shall be reported as “Detected, but Not Quantified,” or DNQ. The estimated chemical concentration of the sample shall also be reported.

For purposes of data collection, the laboratory shall write the estimated chemical concentration next to DNQ. The laboratory may, if such information is available, include numerical estimates of the data quality for the reported result. Numerical estimates of data quality may be percent accuracy (+/- a percentage of the reported value), numerical ranges (low to high), or any other means the laboratory considers appropriate.

- c. Sample results less than the laboratory’s MDL shall be reported as “Not Detected”, or ND.
- d. The Discharger shall instruct laboratories to establish calibration standards so that the minimum level (ML) value (or its equivalent if there is differential treatment of samples relative to calibration standards) is the lowest calibration standard. At no time is the

Discharger to use analytical data derived from extrapolation beyond the lowest point of the calibration curve.

- 6. Compliance Determination.** Compliance with effluent limitations for priority pollutants shall be determined using sample reporting protocols defined above and in the Fact Sheet and Attachments A, D, and G. For purposes of reporting and administrative enforcement by the Regional Water Board and State Water Board, the Discharger shall be deemed out of compliance with effluent limitations if the concentration of the priority pollutant in the monitoring sample is greater than the effluent limitation and greater than or equal to the RL.

C. Discharge Monitoring Reports (DMRs)

If required, the Discharger shall electronically certify and submit DMRs with SMRs using the Electronic Self-Monitoring Reports module eSMR 2.5 or the latest upgraded version. As of the effective date of this Order, electronic DMR submittal is not required. However, at any time during the term of this Order, the State Water Board or Regional Water Board may notify and require the Discharger to submit DMRs. Information about electronic DMR submittal is available at the DMR website at http://www.waterboards.ca.gov/water_issues/programs/discharge_monitoring.

IX. MODIFICATIONS TO ATTACHMENT G

This MRP modifies Attachment G as indicated below:

A. Attachment G section V.C.1.c.2 is revised as follows:

- 2) When determining compliance with an average monthly or maximum daily effluent limitation, and more than one sample result is available, the Discharger shall compute the arithmetic mean unless the data set contains one or more reported determinations of detected but not quantified (DNQ) or nondetect (ND). In those cases, the Discharger shall compute the median in place of the arithmetic mean in accordance with the following procedure:
 - i. The data set shall be ranked from low to high, reported ND determinations lowest, DNQ determinations next, followed by quantified values (if any). The order of the individual ND or DNQ determinations is unimportant.
 - ii. The median value of the data set shall be determined. If the data set has an odd number of data points, then the median is the middle value. If the data set has an even number of data points, then the median is the average of the two values around the middle unless one or both of the points are ND or DNQ, in which case the median value shall be the lower of the two data points where DNQ is lower than a value and ND is lower than DNQ.

If a sample result, or the arithmetic mean or median of multiple sample results, is below the reporting limit, and there is evidence that the priority pollutant is present in the effluent above an effluent limitation and the Discharger conducts a Pollutant Minimization Program, the Discharger shall not be deemed out of compliance.

B. Attachment G sections V.C.1.f and V.C.1.g are revised as follows, and section V.C.1.h (Reporting data in electronic format) is deleted:

f. Annual self-monitoring report requirements

By the date specified in the MRP, the Discharger shall submit an annual report to the Regional Water Board covering the previous calendar year. The report shall contain the following:

- 1) Annual compliance summary table of treatment plant performance, including documentation of any blending events (this summary table is not required if the Discharger has submitted the year's monitoring results to CIWQS in electronic reporting format by EDF/CDF upload or manual entry);
- 2) Comprehensive discussion of treatment plant performance and compliance with the permit (This discussion shall include any corrective actions taken or planned, such as changes to facility equipment or operation practices that may be needed to achieve compliance, and any other actions taken or planned that are intended to improve performance and reliability of the Discharger's wastewater collection, treatment, or disposal practices.);
- 3) Both tabular and graphical summaries of the monitoring data for the previous year if parameters are monitored at a frequency of monthly or greater (this item is not required if the Discharger has submitted the year's monitoring results to CIWQS in electronic reporting format by EDF/CDF upload or manual entry);
- 4) List of approved analyses, including the following:
 - (i) List of analyses for which the Discharger is certified;
 - (ii) List of analyses performed for the Discharger by a separate certified laboratory (copies of reports signed by the laboratory director of that laboratory shall not be submitted but be retained onsite); and
 - (iii) List of "waived" analyses, as approved;
- 5) Plan view drawing or map showing the Discharger's facility, flow routing, and sampling and observation station locations;
- 6) Results of annual facility inspection to verify that all elements of the SWPP Plan are accurate and up to date (only required if the Discharger does not route all stormwater to the headworks of its wastewater treatment plant); and
- 7) Results of facility report reviews (The Discharger shall regularly review, revise, and update, as necessary, the O&M Manual, the Contingency Plan, the Spill Prevention Plan, and Wastewater Facilities Status Report so that these documents remain useful and relevant to current practices. At a minimum, reviews shall be conducted annually. The Discharger shall include, in each Annual Report, a description or summary of review and evaluation procedures, recommended or planned actions, and an estimated time schedule for implementing these actions.

The Discharger shall complete changes to these documents to ensure they are up-to-date.).

g. Report submittal

The Discharger shall submit SMRs addressed as follows, unless the Discharger submits SMRs electronically to CIWQS:

California Regional Water Quality Control Board
San Francisco Bay Region
1515 Clay Street, Suite 1400
Oakland, CA 94612
Attn: NPDES Wastewater Division

h. Reporting data in electronic format – *Deleted*

C. Attachment G sections V.E.2, V.E.2.a, and V.E.2.c are revised as follows, and sections V.E.2.b (24-hour Certification) and V.E.2.d (Communication Protocol) are deleted:

2. Unauthorized Discharges from Municipal Wastewater Treatment Plants¹

The following requirements apply to municipal wastewater treatment plants that experience an unauthorized discharge at their treatment facilities and supersede requirements imposed on the Discharger by the Executive Officer by letter of May 1, 2008.

a. Two (2)-Hour Notification

For any unauthorized discharges that enter a drainage channel or a surface water, the Discharger shall, as soon as possible, but not later than two (2) hours after becoming aware of the discharge, notify the California Office of Emergency Services (CalOES, currently 800-852-7550), the local health officers or directors of environmental health with jurisdiction over the affected water bodies, and the Regional Water Board. Timely notification by the Discharger to CalOES also satisfies notification to the Regional Water Board. Notification shall include the following:

- 1) Incident description and cause;
- 2) Location of threatened or involved waterway(s) or storm drains;
- 3) Date and time the unauthorized discharge started;
- 4) Estimated quantity and duration of the unauthorized discharge (to the extent known), and the estimated amount recovered;

¹ California Code of Regulations, Title 23, Section 2250(b), defines an unauthorized discharge to be a discharge, not regulated by waste discharge requirements, of treated, partially treated, or untreated wastewater resulting from the intentional or unintentional diversion of wastewater from a collection, treatment or disposal system.

- 5) Level of treatment prior to discharge (e.g., raw wastewater, primary treated, undisinfectated secondary treated, and so on); and
 - 6) Identity of the person reporting the unauthorized discharge.
- b. 24-hour Certification – *Deleted*
- c. 5-day Written Report

Within five business days, the Discharger shall submit a written report that includes, in addition to the information required above, the following:

- 1) Methods used to delineate the geographical extent of the unauthorized discharge within receiving waters;
 - 2) Efforts implemented to minimize public exposure to the unauthorized discharge;
 - 3) Visual observations of the impacts (if any) noted in the receiving waters (e.g., fish kill, discoloration of water) and the extent of sampling if conducted;
 - 4) Corrective measures taken to minimize the impact of the unauthorized discharge;
 - 5) Measures to be taken to minimize the chances of a similar unauthorized discharge occurring in the future;
 - 6) Summary of Spill Prevention Plan or O&M Manual modifications to be made, if necessary, to minimize the chances of future unauthorized discharges; and
 - 7) Quantity and duration of the unauthorized discharge, and the amount recovered.
- d. Communication Protocol – *Deleted*

ATTACHMENT F - FACT SHEET

Contents

I. Permit Information..... F-3

II. Facility Description..... F-4

 A. Wastewater Treatment..... F-4

 B. Discharge Points and Receiving Waters F-6

 C. Previous Requirements and Monitoring Data F-6

 D. Compliance Summary F-8

 E. Planned Changes F-11

III. Applicable Plans, Policies, and Regulations..... F-12

IV. Rationale For Effluent Limitations and Discharge Specifications F-15

 A. Discharge Prohibitions F-15

 B. Conventional and Non-Conventional Pollutant Effluent Limitations F-17

 1. Scope and Authority..... F-17

 2. Effluent Limitations F-18

 C. Toxic Pollutant Effluent Limitations..... F-19

 1. Scope and Authority..... F-19

 2. Beneficial Uses and Water Quality Criteria and Objectives F-19

 3. Need for Water Quality-Based Effluent Limitations (Reasonable Potential Analysis) .. F-22

 4. Water Quality-Based Effluent Limitations (WQBELs) F-31

 D. Discharge Requirement Considerations F-39

V. Rationale for Receiving Water Limitations F-40

VI. Rationale for Provisions..... F-40

 A. Standard Provisions..... F-40

 B. Monitoring and Reporting F-40

 C. Special Provisions F-41

 1. Reopener Provisions..... F-41

 2. Effluent Characterization Study and Report F-41

 3. Receiving Water Characterization Study and Report..... F-41

 4. Pollutant Minimization Program F-41

 5. Special Provisions for Municipal Facilities..... F-41

 6. Wastewater Pond Operation Requirements..... F-42

 7. Anaerobically Digestible Material F-42

 8. Conditions for Discharge Point No. 003 F-42

 9. Amendment of NPDES Permit No. CA0038849 F-43

VII. Rationale for Monitoring and Reporting Program (MRP) F-43

VIII. Public Participation F-45

Tables

Table F-1. Facility Information..... F-3

Table F-2. Previous Effluent Limitations and Monitoring Data..... F-6

Table F-3. Effluent Limitation Violations F-8

Table F-4. Collection System and SSO Rates (SSO/100 miles).....F-11
Table F-5. Beneficial Uses.....F-12
Table F-6. Secondary Treatment Standards.....F-17
Table F-7. Priority Pollutant Reasonable Potential Analysis.....F-23
Table F-8. Municipal and Agricultural Supply Pollutant Reasonable Potential Analysis.....F-29
Table F-9. WQBEL Calculations.....F-36
Table F-10. Monitoring Requirements Summary.....F-44

ATTACHMENT F – FACT SHEET

This Fact Sheet includes the legal requirements and technical rationale that serve as the basis for the requirements of this Order. As described in section II.B of this Order, the California Regional Water Quality Control Board, San Francisco Bay Region (Regional Water Board) incorporates this Fact Sheet as findings supporting the issuance of this Order.

I. PERMIT INFORMATION

The following table summarizes administrative information related to the facility:

Table F-1. Facility Information

WDID	2 283003001
CIWQS Place ID	212750
Discharger	City of Calistoga
Facility Name	Dunaweal Wastewater Treatment Plant and its associated collection system
Facility Address	1100 Dunaweal Lane Calistoga, CA 94515 Napa County
Facility Contact, Title, Phone	Mike Kirn, Public Works Director, (707) 942-2828
Authorized Person to Sign and Submit Reports	Mike Kirn, Public Works Director, (707) 942-2828
Mailing Address	414 Washington Street Calistoga, CA 94515
Billing Address	1232 Washington Street Calistoga, CA 94515
Facility Type	Publicly Owned Treatment Works (POTW)
Major or Minor Facility	Minor
Threat to Water Quality	2
Complexity	B
Pretreatment Program	No
Recycled Water Requirements	Regional Water Board Order No. 96-011
Mercury and PCBs Requirements	NPDES Permit No. CA0038849
Permitted Flow	0.84 million gallons per day (MGD) – average dry weather flow
Design Flow	0.84 MGD – average dry weather treatment capacity (tertiary) 4.0 MGD – peak wet weather treatment capacity (combined secondary and tertiary)
Watershed	San Pablo Bay
Receiving Water	Napa River
Receiving Water Type	Freshwater

- A. The City of Calistoga (Discharger) owns and operates the Dunaweal Wastewater Treatment Plant, and its associated collection system (collectively the Facility). The Facility provides secondary and tertiary treatment of wastewater collected from its service area and discharges to the Napa River.

For the purposes of this Order, references to the “discharger” or “permittee” in applicable federal and State laws, regulations, plans, or policy are held to be equivalent to references to the Discharger herein.

The Discharger is authorized to discharge subject to waste discharge requirements in this Order at the discharge points listed in Table 2 of this Order. Regulations at 40 C.F.R. section 122.46 limit the duration of NPDES permits to a fixed term not to exceed five years. Accordingly, Table 3 of this Order limits the effective period for the discharge authorization. Pursuant to California Code of Regulations, title 23, section 2235.4, the terms and conditions of an expired permit are automatically continued pending reissuance of the permit if the Discharger complies with all federal NPDES regulation requirements for continuation of expired permits.

- B. The Facility discharges wastewater to the Napa River, a water of the United States within the San Pablo Bay watershed. Attachment B provides maps of the area around the Facility.

When applicable, State law requires dischargers to file a petition with the State Water Resources Control Board (State Water Board), Division of Water Rights, and receive approval for any change in the point of discharge, place of use, or purpose of use of treated wastewater that decreases the flow in any portion of a watercourse. The State Water Board retains separate jurisdictional authority to enforce such requirements under Water Code 1211. This is not an NPDES permit requirement.

- C. The discharges are regulated pursuant to National Pollutant Discharge Elimination System (NPDES) Permit No. CA0037966. The discharges were previously subject to Order No. R2-2010-0104 (previous order). The Discharger filed a Report of Waste Discharge and submitted an application for reissuance of its Waste Discharge Requirements (WDRs) and NPDES permit on May 1, 2015.
- D. The discharges are also regulated under NPDES Permit No. CA0038849, which establishes requirements on mercury and polychlorinated biphenyls (PCBs). Provision VI.C.9 of this Order amends that permit to accommodate a new outfall from this Facility.

The discharges are subject to Cease and Desist Order No. R2-2014-0043 (see Fact Sheet section II.D).

Tertiary-treated effluent that is recycled and not discharged is regulated under Order No. 96-011.

II. FACILITY DESCRIPTION

A. Wastewater Treatment

1. **Location and Service Area.** The plant is located at 1100 Dunaweal Lane in Calistoga. It provides secondary and tertiary level treatment for domestic, commercial, and some industrial wastewater from the City of Calistoga. The service area population is about 5,200. Attachment B provides maps of the area around the Facility.
2. **Collection System.** The Discharger operates about 18 miles of major sewer lines and 4 pump stations for the City of Calistoga.
3. **Wastewater Treatment** The treatment process consists of a headworks, secondary treatment, tertiary treatment, and disinfection. A 5.6 million gallon (MG) flow equalization basin is used to equalize flows and provide emergency storage, and can hold wastewater from any step in the treatment process. The plant has an average dry weather treatment

capacity of 0.84 MGD and a peak wet weather capacity of 4.0 MGD. From March 2014 through February 2015, the average daily flow was 0.54 MGD and the maximum daily flow was 2.3 MGD. Tertiary-treated effluent is discharged to the Napa River through Discharge Point No. 001; during wet weather, secondary-treated effluent is also discharged through Discharge Point No. 002. During the term of this Order, the Discharger may reconstruct and (if it meets the conditions set forth in Provision VI.C.8 of this Order) discharge tertiary-treated effluent through Discharge Point No. 003 as discussed below and in Fact Sheet section II.A.7. Attachment C provides a flow schematic, which includes Discharge Point No. 003.

- **Headworks.** Wastewater from the collection system is screened at the headworks and sent to a primary distribution structure, which distributes it to two aeration basins.
- **Secondary Treatment.** In the two aeration basins, biological treatment occurs through an activated sludge process. Wastewater flows from the aeration basins to one of two clarifiers, where sludge settles and is removed. Sludge is either returned to the primary distribution structure or directed to a sludge holding tank. Two filter pumps pump clarified effluent to filters.
- **Tertiary Treatment.** The filters provide tertiary treatment. A polymer coagulant is injected at the filter pumps to aid filtration.
- **Disinfection.** Prior to discharge to the Napa River at Discharge Point No. 001, filtered effluent flows to a chlorine contact tank where it is injected with a chlorine solution and mechanically mixed. Tertiary-treated effluent is de-chlorinated and, prior to discharge from Discharge Point No. 001, discharged to a series of four Riverside Ponds for further polishing treatment. The total pond area is 2.7 acres. Effluent stored in the Riverside Ponds can be returned for further treatment if it does not meet effluent limitations.

When the tertiary filter capacity of 1 MGD is exceeded, tertiary treatment, tertiary discharge, and equalization storage are maximized, and Napa River flow is sufficiently high, secondary-treated effluent may be pumped to a separate chlorine contact tank, bypassing the filters. The secondary-treated effluent is then dechlorinated and discharged at Discharge Point No. 002.

If Discharge Point No. 003 is authorized under Provision VI.C.8, it will be used in conjunction with Discharge Point No. 001 to discharge tertiary-treated wastewater in accordance with Prohibition III.B. Discharges from Discharge Point No. 003 will undergo the same treatment as discharges from Discharge Point No. 001, except that they will not flow through the Riverside Ponds. The Discharger plans to install aeration and mixing equipment in the 20-MG pond to ensure adequate treatment of chlorodibromomethane and dichlorobromomethane, and is required to demonstrate the ability to comply with those limits before Discharge Point No. 003 is authorized for use under Provision VI.C.8 (see also Fact Sheet section VI.C.8).

4. **Wastewater Recycling.** Tertiary-treated wastewater is recycled or stored in either a 20-MG effluent storage pond, a 10-MG storage pond, or a newly-constructed 16-MG recycled water storage pond for future reuse or disposal. The Discharger provides recycled water to 14 customers for golf course and landscape irrigation.

5. **Biosolids Management.** Sludge from the secondary clarifiers is periodically collected and stored in a 72,000-gallon sludge holding tank. Sludge is pumped from the sludge holding tank to sludge drying beds and then trucked offsite for further treatment or disposal in accordance with U.S. EPA regulations.
6. **Stormwater.** All stormwater captured within the plant grounds is directed to the headworks for treatment. Coverage under the statewide NPDES permit for stormwater discharges associated with industrial activities (NPDES General Permit No. CAS000001) is therefore not required.
7. **Facility Upgrades.** To augment the Facility as described above, the Discharger is considering improvements to comply with Cease and Desist Order No. R2-2014-0043. The improvements would be intended to prevent bypasses and comply with antimony effluent limits. See subsection E, below.

The Discharger is also considering reconstructing an existing outfall from the 20-MG effluent storage pond to the Napa River, which would be used to discharge tertiary-treated effluent (Discharge Point No. 003). This outfall was decommissioned in approximately 2003, when the plant was upgraded from a pond treatment system to the current activated sludge system (the 20-MG storage pond was previously an oxidation pond). Discharge Point No. 003 is further described in Fact Sheet section IV.C.4.a.

B. Discharge Points and Receiving Waters

Discharge Point Nos. 001, 002, and 003 are shallow water outfalls extending from the east bank of the river without diffusers. Tertiary-treated effluent is discharged at Discharge Point Nos. 001 and 003 when the river flow-to-effluent flow ratio is at least 10:1 (flows from Discharge Point Nos. 001 and 003 are to be combined in calculating this river flow-to-effluent flow ratio to ensure a 10:1 river flow-to-effluent flow ratio for simultaneous discharges of tertiary-treated wastewater from both discharge points). Secondary-treated effluent is discharged at Discharge Point No. 002 when the river flow-to-effluent flow ratio is at least 50:1.

C. Previous Requirements and Monitoring Data

The following tables present the previous order’s effluent limitations and representative monitoring data from the previous order term:

Table F-2. Previous Effluent Limitations and Monitoring Data

Parameter	Units	Effluent Limitations					Monitoring Data (12/13/10-5/13/15)
		Monthly Average	Weekly Average	Daily Maximum	Instant-aneous Minimum	Instant-aneous Maximum	Highest Daily Discharge
Discharge Point No. 001							
Biochemical Oxygen Demand, 5-day @ 20°C (BOD ₅)	mg/L	10	15	---	---	---	13 ^[1]
Total Suspended Solids	mg/L	15	20	---	---	---	11 ^[2]

Parameter	Units	Effluent Limitations					Monitoring Data (12/13/10-5/13/15)
		Monthly Average	Weekly Average	Daily Maximum	Instantaneous Minimum	Instantaneous Maximum	Highest Daily Discharge
(TSS)							
Oil and Grease	mg/L	5.0	---	10	---	---	5.0
Turbidity	NTU	---	---	10	---	---	4.7
pH	standard units	---	---	---	6.5	8.5	6.5-8.7 ^[3]
Residual Chlorine, Total	mg/L	---	---	---	---	0.0	0.0
Total Coliform Bacteria	MPN/100mL	23 MPN/100mL (5-Day Moving Median)					5.0
		240 MPN/100mL (Single Sample)					
Discharge Point No. 002							
BOD ₅	mg/L	30	45	---	---	---	17
TSS	mg/L	30	45	---	---	---	26
Oil and Grease	mg/L	10	---	20	---	---	2.7
pH	standard units	---	---	---	6.5	8.5	6.2-8.2 ^[3]
Residual Chlorine, Total	mg/L	---	---	---	---	0.0	0.0
Total Coliform Bacteria	MPN/100mL	23 MPN/100mL (5-Day Moving Median)					33
		240 MPN/100mL (Single Sample)					
Discharge Point Nos. 001 and 002 ^[4]							
Antimony	µg/L	25	---	36	---	---	45
Copper	µg/L	11	---	20	---	---	10
Cyanide	µg/L	7.3	---	18	---	---	6.9
Chlorodibromomethane	µg/L	3.4	---	6.4	---	---	9.1
Dichlorobromomethane	µg/L	4.9	---	9.0	---	---	22
Dioxin-TEQ	µg/L	1.3 x 10 ⁻⁸	---	2.6 x 10 ⁻⁸	---	---	3.6 x 10 ⁻¹¹
Acute Toxicity	% Survival	Not less than 90% (11-Sample Median)					100
		Not less than 70% (11-Sample 90 th Percentile)					0
Chronic Toxicity	TUc	No chronic toxicity in discharge as discharged ^[5]					2.2

Unit Abbreviations:

- µg/L = micrograms per liter
- mg/L = milligrams per liter
- mg/L as N = milligrams per liter as nitrogen
- MPN/100mL = most probable number per 100 milliliters
- NTU = nephelometric turbidity units
- % Survival = percent survival
- TUc = chronic toxicity units, equal to 100/NOEL, where NOEL = IC₂₅, EC₂₅, or NOEC

Footnote:

- ^[1] The minimum BOD₅ percent removal was 96 percent. The previous order required 85 percent removal.
- ^[2] The minimum TSS percent removal was 97 percent. The previous order required 85 percent removal.
- ^[3] Range of highest and lowest pH values. The previous order pH limits were not exceeded because the Discharger corrected pH excursions within 60 minutes as required.
- ^[4] The highest daily discharge values presented are the highest values observed at either Discharge Point No. 001 or 002.
- ^[5] The previous order contained the following triggers for accelerated monitoring and toxicity reduction efforts: 20 TUc in a single sample and 10 TUc as a three-sample median.

D. Compliance Summary

1. Effluent Limitation Violations. The Discharger violated its effluent limitations 49 times from December 2010 through August 2015. Of these, 35 were violations of the chlorodibromomethane or dichlorobromomethane effluent limits which Cease and Desist Order No. R2-2010-0107 was intended to address (see below). Of the remaining 14 violations, 13 were violations of the antimony limits, which is being addressed by Cease and Desist Order No. R2-2014-0043 (see below). The Discharger violated the acute toxicity effluent limit once.

Table F-3. Effluent Limitation Violations

Monitoring Location	Violation Date	Parameter	Unit	Effluent Limit	Reported Value
EFF-001	December 31, 2010	Chlorodibromomethane, Average Monthly	µg/L	3.4	4.3 ^[1]
EFF-001	December 31, 2010	Dichlorobromomethane, Average Monthly	µg/L	4.9	8.2 ^[1]
EFF-001	January 4, 2011	Dichlorobromomethane, Daily Maximum	µg/L	9.0	17 ^[1]
EFF-002	January 4, 2011	Dichlorobromomethane, Daily Maximum	µg/L	9.0	14 ^[1]
EFF-001	January 20, 2011	Chlorodibromomethane, Daily Maximum	µg/L	6.4	9.1 ^[1]
EFF-002	January 20, 2011	Chlorodibromomethane, Daily Maximum	µg/L	6.4	9.0 ^[1]
EFF-001	January 20, 2011	Dichlorobromomethane, Daily Maximum	µg/L	9.0	22 ^[1]
EFF-002	January 20, 2011	Dichlorobromomethane, Daily Maximum	µg/L	9.0	22 ^[1]
EFF-001	January 31, 2011	Chlorodibromomethane, Average Monthly	µg/L	3.4	6.9 ^[1]
EFF-002	January 31, 2011	Chlorodibromomethane, Average Monthly	µg/L	3.4	6.8 ^[1]
EFF-001	January 31, 2011	Dichlorobromomethane, Average Monthly	µg/L	4.9	19 ^[1]
EFF-002	January 31, 2011	Dichlorobromomethane, Average Monthly	µg/L	4.9	18 ^[1]
EFF-002	February 23, 2011	Chlorodibromomethane, Daily Maximum	µg/L	6.4	6.8 ^[1]
EFF-002	February 23, 2011	Dichlorobromomethane, Daily Maximum	µg/L	9.0	15 ^[1]
EFF-001	February 28, 2011	Chlorodibromomethane, Average Monthly	µg/L	3.4	6.4 ^[1]
EFF-002	February 28, 2011	Chlorodibromomethane, Average Monthly	µg/L	3.4	6.8 ^[1]
EFF-002	March 23, 2011	Dichlorobromomethane, Daily Maximum	µg/L	9.0	9.4 ^[1]
EFF-002	March 31, 2011	Dichlorobromomethane, Average Monthly	µg/L	4.9	9.4 ^[1]
EFF-001	April 19, 2011	Dichlorobromomethane, Daily Maximum	µg/L	9.0	9.3 ^[1]
EFF-001	April 30, 2011	Chlorodibromomethane, Average Monthly	µg/L	3.4	4.2 ^[1]
EFF-001	April 30, 2011	Dichlorobromomethane, Average Monthly	µg/L	4.9	9.3 ^[1]
EFF-001	May 31, 2011	Antimony, Average Monthly	µg/L	25	31
EFF-001	December 31, 2011	Antimony, Average Monthly	µg/L	25	36
EFF-001	January 31, 2012	Antimony, Average Monthly	µg/L	25	28
EFF-001	February 28, 2012	Antimony, Daily Maximum	µg/L	36	39
EFF-001	February 29, 2012	Antimony, Average Monthly	µg/L	25	32
EFF-001	May 16, 2012	Acute Toxicity, 11-sample 90 th percentile minimum survival	% survival	70	0
EFF-002	December 4, 2012	Antimony, Daily Maximum	µg/L	36	45
EFF-002	December 4, 2012	Dichlorobromomethane, Daily Maximum	µg/L	9.0	18 ^[1]
EFF-002	December 31, 2012	Antimony, Average Monthly	µg/L	25	34
EFF-002	December 31, 2012	Chlorodibromomethane, Average Monthly	µg/L	3.4	6.0 ^[1]

Monitoring Location	Violation Date	Parameter	Unit	Effluent Limit	Reported Value
EFF-001	December 31, 2012	Dichlorobromomethane, Average Monthly	µg/L	4.9	8.6 ^[1]
EFF-002	December 31, 2012	Dichlorobromomethane, Average Monthly	µg/L	4.9	18 ^[1]
EFF-002	February 12, 2014	Chlorodibromomethane, Daily Maximum	µg/L	6.4	6.9 ^[1]
EFF-002	February 12, 2014	Dichlorobromomethane, Daily Maximum	µg/L	9.0	20 ^[1]
EFF-001	February 28, 2014	Antimony, Average Monthly	µg/L	25	28
EFF-002	February 28, 2014	Antimony, Average Monthly	µg/L	25	29
EFF-001	February 28, 2014	Chlorodibromomethane, Average Monthly	µg/L	3.4	6.8 ^[1]
EFF-002	February 28, 2014	Chlorodibromomethane, Average Monthly	µg/L	3.4	6.9 ^[1]
EFF-001	February 28, 2014	Dichlorobromomethane, Average Monthly	µg/L	4.9	17 ^[1]
EFF-002	February 28, 2014	Dichlorobromomethane, Average Monthly	µg/L	4.9	20 ^[1]
EFF-001	March 31, 2014	Antimony, Average Monthly	µg/L	25	29
EFF-002	March 31, 2014	Antimony, Average Monthly	µg/L	25	30
EFF-002	December 16, 2014	Dichlorobromomethane, Daily Maximum	µg/L	9.0	11
EFF-002	December 31, 2014	Dichlorobromomethane, Average Monthly	µg/L	4.9	11
EFF-001	January 31, 2015	Antimony, Average Monthly	µg/L	25	26 ^[2]
EFF-001	January 6, 2015	Dichlorobromomethane, Daily Maximum	µg/L	9.0	9.5
EFF-001	January 31, 2015	Dichlorobromomethane, Average Monthly	µg/L	4.9	9.5
EFF-001	April 30, 2015	Antimony, Average Monthly	µg/L	25	27 ^[2]

Footnotes:

^[1] Cease and Desist Order No. R2-2010-0107 established the following interim effluent limits for chlorodibromomethane and dichlorobromomethane at Discharge Point Nos. 001 and 002:

Chlorodibromomethane: 14 µg/L maximum daily effluent limitation
Dichlorobromomethane: 36 µg/L maximum daily effluent limitation

These limits were effective from November 1, 2010, to August 31, 2014.

^[2] Cease and Desist Order No. R2-2014-0043 established an interim antimony effluent limit of 43 µg/L at Discharge Point Nos. 001 and 002.

a. Chlorodibromomethane and Dichlorobromomethane. The Regional Water Board adopted Cease and Desist Order No. R2-2010-0107 on September 8, 2010, to address threatened violations of the previous order’s chlorodibromomethane and dichlorobromomethane effluent limits. It established interim maximum daily effluent limitations (MDELS) for chlorodibromomethane and dichlorobromomethane. It also established tasks and a time schedule for the Discharger to achieve compliance with the previous order’s limits by August 31, 2014, and required submittal of further tasks and a time schedule to comply as soon as possible if the Discharger failed to fully comply by then.

On August 31, 2014, the Discharger reported compliance with the chlorodibromomethane and dichlorobromomethane limits at Discharge Point No. 001, but not at Discharge Point No. 002. The Discharger also proposed to investigate several potential treatment measures, but did not provide the required tasks and time schedule. The Regional Water Board issued a Notice of Violation on December 3, 2014, requiring such tasks and a schedule, which the Discharger provided on December 29, 2014, and continues to implement. The Discharger has not discharged through Discharge Point No. 002 since December 2014; the Regional Water Board will evaluate whether the Discharger has

achieved compliance with the chlorodibromomethane and dichlorobromomethane limits when discharges from Discharge Point No. 002 resume.

The Discharger violated the dichlorobromomethane limits at Discharge Point No. 001 in January 2015; four accelerated monitoring samples collected in February 2015 were below the limit. The Discharger has not used Discharge Point No. 001 since February 2015; the Regional Water Board will continue to monitor the Discharger's compliance when discharges from this point resume. Violations of the chlorodibromomethane and dichlorobromomethane limits since August 31, 2014, are subject to further enforcement.

- b. Antimony.** The Regional Water Board adopted Cease and Desist Order No. R2-2014-0043 on November 17, 2014, to address threatened violations of the previous order's antimony limits. It established an interim antimony MDEL, and tasks and a time schedule for the Discharger to achieve compliance with the previous order's limits by October 31, 2019. For the four antimony limit violations that occurred from December 31, 2011, through February 29, 2012, the Executive Officer issued Order No. R2-2013-1016, fining the Discharger \$6,000 in mandatory minimum penalties. The four antimony violations that occurred between February 29, 2012, and November 17, 2014, remain subject to further enforcement.
 - c. Acute Toxicity.** The May 16, 2012, violation of the 90th percentile minimum percent survival limit resulted from two bioassays, each with zero percent survival. The Discharger determined the cause of the toxicity to be high concentrations of the coagulant polymer added prior to filtration. The Discharger reduced the coagulant dose to its previous concentration, and subsequent monitoring showed compliance with the acute toxicity limit.
- 2. Discharge Prohibition Violations.** The Discharger bypassed partially secondary-treated wastewater to the Napa River on January 23, 2012, and undisinfected secondary-treated wastewater to the Napa River on December 22 and 23, 2012, in violation of Prohibition III.C of the previous order. In three separate events, the Discharger also bypassed tertiary-treated wastewater to land as an emergency measure pursuant to Attachment D, sections I.G.3 and I.G.4, of the previous order. Details of these bypasses are below. The Regional Water Board adopted Cease and Desist Order No. R2 2014-0043 to require tasks and a time schedule to eliminate the need for future emergency bypasses by January 31, 2018.

 - a. January 23, 2012.** A faulty valve resulted in an unauthorized discharge. The valve failed to close, allowing discharge of partially secondary-treated wastewater combined with secondary-treated and tertiary-treated wastewater. The combined volume discharged was about 709,000 gallons, all of which was disinfected and dechlorinated. On June 1, 2012, Regional Water Board staff issued a Notice of Violation that required the Discharger to submit plans and take corrective actions to prevent additional discharges. The Discharger replaced the faulty valve in December 2012, developed a standard operating procedure for valve operation, and re-trained plant personnel.
 - b. December 22 and 23, 2012.** Plant staff failed to close a valve, resulting in an unauthorized discharge of about 250,000 gallons of un-disinfected secondary-treated wastewater, combined with about 750,000 gallons of disinfected secondary-treated wastewater. Regional Water Board staff inspected the Facility on March 28, 2013. On

May 13, 2013, Regional Water Board staff issued a Notice of Violation based on the findings of the March 28 inspection, noting that the Discharger had yet to determine a permanent corrective action to prevent recurrence. In response, the Discharger developed and submitted a new standard operating procedure that includes checking valve positions when preparing to discharge secondary-treated effluent.

c. Emergency Bypasses. Historically low rainfall and extended drought conditions since 2011 significantly reduced the Discharger’s opportunities to discharge. For extended periods, Napa River flows were too low to provide the dilution that the previous order required as a condition of discharge. On three occasions, the Discharger exhausted its storage facilities and requested and received authorization for an emergency bypass under Attachment D, sections I.G.3 and I.G.4, of the previous order. The bypasses consisted of tertiary-treated effluent discharged to Discharger-owned irrigation fields, with runoff flowing overland to the Napa River. In approving these bypasses, Regional Water Board staff concluded that discharging to the irrigation fields was preferable to direct discharge to the Napa River because a smaller volume would reach the Napa River.

3. Collection System. The table below shows the Discharger’s sanitary sewer overflow (SSO) rates (total SSOs per 100 miles of collection system for each of the past four years) and other information along with those for the county and region. The Discharger had at least one SSO in each year from 2011 through 2014 and two in 2013. The total SSO volume in any given year did not exceed 30 gallons, and no discharge to waters of the United States occurred.

Table F-4. Collection System and SSO Rates (SSO/100 miles)
 (values based on CIWQS data analysis completed in July 2015) ^[1]

	Length (miles)	Average Age (years) ^[2]	2011	2012	2013	2014
Calistoga	18	45	6.3	6.3	12.5	6.3
Napa County average of 3 medium systems (10 to 99 miles)	30	39	2.7	4.8	4.2	4.6
San Francisco Bay Region average of 49 medium systems (10 to 99 miles)	38	42	5.9	9.3	11.5	6.3
San Francisco Bay Region median of all 132 systems	42	45	4.0	4.6	4.5	2.7

Footnotes:

^[1] The State Water Board’s Enrollee’s Guide to the SSO Database defines “Total number of SSOs per 100 miles of Sewer” as “...the number of SSOs, for which the reporting Enrollee is responsible, for every 100 miles of pipe or sewer lines in an Enrollee’s sanitary sewer system. Due to the large variation in facility specific characteristics, this metric should only be viewed as a rough comparison of the operation and maintenance performance of Enrollees and their sanitary sewer systems.”

^[2] Average age as of 2014.

E. Planned Changes

The Discharger is considering the following projects during the term of this Order. These changes are for informational purposes only, and are not requirements of this Order, except to the extent that they pertain to increasing or ensuring the reliability of treatment or wastewater collection systems, or compliance with this Order’s requirements. Their inclusion here does not imply Regional Water

Board authorization. The Discharger may need to seek permits or permit modifications to implement these changes:

1. Install air diffusers, sprayers, or aerators in secondary effluent chlorine contact chamber, Riverside Ponds, and storage pond outlet to reduce disinfection byproduct concentrations (such as for chlorodibromomethane and dichlorobromomethane).
2. Restore and rebuild the Riverside Ponds to address seepage.
3. Build advanced treatment unit to remove boron and antimony.
4. Integrate discharge flow measurements at Discharge Point No. 003 with river flow measurements at the Dunaweal Bridge to achieve real time compliance with minimum river flow-to-effluent flow ratio requirements.
5. Install screw press to improve sludge handling.

III. APPLICABLE PLANS, POLICIES, AND REGULATIONS

A. Legal Authorities

This Order serves as WDRs pursuant to California Water Code article 4, chapter 4, division 7 (commencing with § 13260). This Order is also issued pursuant to Clean Water Act (CWA) section 402 and implementing regulations adopted by U.S. EPA, and Water Code chapter 5.5, division 7 (commencing with § 13370). It shall serve as an NPDES permit for point source discharges from this facility to surface waters.

B. California Environmental Quality Act

Under Water Code section 13389, this action to adopt an NPDES permit is exempt from the provisions of the California Environmental Quality Act, Public Resources Code division 13, chapter 3 (commencing with § 21100).

C. State and Federal Regulations, Policies, and Plans

1. **Water Quality Control Plan.** The Regional Water Board adopted the *Water Quality Control Plan for the San Francisco Bay Basin* (Basin Plan), which designates beneficial uses, establishes water quality objectives, and contains implementation programs and policies to achieve those objectives for all waters addressed through the plan. Requirements in this Order implement the Basin Plan. In addition, this Order implements State Water Board Resolution No. 88-63, which established state policy that all waters, with certain exceptions, should be considered suitable or potentially suitable for municipal or domestic supply. Beneficial uses applicable to the Napa River are as follows:

Table F-5. Beneficial Uses

Discharge Points	Receiving Water	Beneficial Uses	
001	Napa River	Agricultural Supply (AGR)	Fish Spawning (SPWN)
002		Municipal and Domestic Supply (MUN)	Warm Freshwater Habitat (WARM)
003		Groundwater Recharge (GWR)	Wildlife Habitat (WILD)

Discharge Points	Receiving Water	Beneficial Uses	
		Commercial and Sport Fishing (COMM) Cold Freshwater Habitat (COLD) Fish Migration (MIGR) Preservation of Rare and Endangered Species (RARE)	Water Contact Recreation (REC1) Non-Contact Water Recreation (REC2) and Navigation (NAV)

2. **National Toxics Rule (NTR) and California Toxics Rule (CTR).** U.S. EPA adopted the NTR on December 22, 1992, and amended it on May 4, 1995 and November 9, 1999. About 40 criteria in the NTR apply in California. On May 18, 2000, U.S. EPA adopted the CTR. The CTR promulgated new toxics criteria for California and incorporated the previously adopted NTR criteria that applied in the State. U.S. EPA amended the CTR on February 13, 2001. These rules contain water quality criteria for priority pollutants.

3. **State Implementation Policy.** On March 2, 2000, the State Water Board adopted the *Policy for Implementation of Toxics Standards for Inland Surface Waters, Enclosed Bays, and Estuaries of California* (State Implementation Policy or SIP). The SIP became effective on April 28, 2000, with respect to the priority pollutant criteria U.S. EPA promulgated for California through the NTR and the priority pollutant objectives the Regional Water Board established in the Basin Plan. The SIP became effective on May 18, 2000, with respect to the priority pollutant criteria U.S. EPA promulgated through the CTR. The State Water Board adopted amendments to the SIP on February 24, 2005, that became effective on July 13, 2005. The SIP establishes implementation provisions for priority pollutant criteria and objectives, and provisions for chronic toxicity control. Requirements of this Order implement the SIP.

4. **Domestic Water Quality.** In accordance with Water Code section 106.3, it is the policy of the State of California that every human being has the right to safe, clean, affordable, and accessible water adequate for human consumption, cooking, and sanitary purposes. This Order complies with that policy by requiring discharges to meet maximum contaminant levels designed to protect human health and ensure that water is safe for domestic use.

5. **Antidegradation Policy.** Federal regulations at 40 C.F.R. section 131.12 requires that state water quality standards include an antidegradation policy consistent with the federal policy. The State Water Board established California's antidegradation policy through State Water Board Resolution No. 68-16, *Statement of Policy with Respect to Maintaining High Quality of Waters in California*, which is deemed to incorporate the federal antidegradation policy where the federal policy applies under federal law. Resolution No. 68-16 requires that existing water quality be maintained unless degradation is justified based on specific findings. The Basin Plan implements, and incorporates by reference, both the State and federal antidegradation policies. Permitted discharges must be consistent with the antidegradation provisions of 40 C.F.R. section 131.12 and State Water Board Resolution No. 68-16.

6. **Anti-Backsliding Requirements.** CWA sections 402(o) and 303(d)(4) and 40 C.F.R. section 122.44(l) restrict backsliding in NPDES permits. These anti-backsliding provisions require that effluent limitations in a reissued permit be as stringent as those in the previous permit, with some exceptions in which limitations may be relaxed.

7. Recycled Water Policy. The State Water Board adopted Resolution No. 2013-0003 on January 22, 2013, titled *Policy for Water Quality Control for Recycled Water*, which is intended to promote sustainable local water supplies by increasing the acceptance and promoting the use of recycled water. The policy sets a goal to increase the use of recycled water statewide by at least one million acre feet per year (afy) over the 2002 baseline-level by 2020 and by at least two million afy by 2030. Consistent with the policy, the Regional Water Board is to exercise its authority to the fullest extent possible to encourage the use of recycled water, and to develop watershed-based salt and nutrient management plans to ensure use of recycled water does not degrade groundwater resources.

D. Impaired Waters on CWA 303(d) List

In October 2011, U.S. EPA approved a revised list of impaired waters pursuant to CWA section 303(d), which requires identification of specific water bodies where it is expected that water quality standards will not be met after implementation of technology-based effluent limitations on point sources. Where it has not done so already, the Regional Water Board plans to adopt total maximum daily loads (TMDLs) for pollutants on the 303(d) list. TMDLs establish wasteload allocations for point sources and load allocations for non-point sources, and are established to achieve the water quality standards for the impaired waters.

The Napa River is listed as impaired by nutrients, pathogens, and sediment. San Pablo Bay, to which the Napa River is tributary, is listed for chlordane, DDT, dieldrin, dioxins and furans, mercury, nickel, PCBs, selenium, and exotic species. The SIP requires final effluent limitations for all 303(d)-listed pollutants to be consistent with TMDLs and associated wasteload allocations.

On February 12, 2008, U.S. EPA approved a TMDL for mercury in San Francisco Bay. On March 29, 2010, U.S. EPA approved a TMDL for PCBs in San Francisco Bay. The TMDLs for mercury and PCBs apply to this discharge but are implemented through NPDES Permit No. CA0038849.

On February 29, 2008, U.S. EPA approved a TMDL for pathogens in the Napa River. This Order's total coliform effluent limitations are more stringent than the Napa River pathogens TMDL requires.

On January 21, 2011, U.S. EPA approved a TMDL for sediment in the Napa River. This Order's TSS effluent limitations are more stringent than specified by the Napa River sediment TMDL (see Basin Plan Table 7.8.4-3b, footnote a).

The discharge is a potential source of nutrients to the Napa River, but is not expected to be a significant contributor to the impairment. The Napa River was listed as impaired for nutrients in the 1970s because of high nutrient levels and excessive algae growth, but water quality has significantly improved as a result of changes in agricultural practices in the watershed and reduced nutrient loads from wastewater treatment plants. In the 1980s, the Regional Water Board started prohibiting wastewater discharges to the river during the dry season when flows are naturally low because of the summer droughts in this Mediterranean climate. While the discharge prohibition in this Order does not apply exclusively to the "dry season," it serves the same function because it limits discharge to the river when there is recycled water demand, which

correlates closely to the dry season. Also, the three treatment plants discharging to the non-tidal portion of the river (Calistoga, St. Helena, and Yountville) have improved their treatment processes since 1970. Receiving water nutrient concentrations (i.e., nitrate, nitrite, and ammonia) and other indicators (i.e., algae and chlorophyll *a*) are now below levels of concern. On February 12, 2014, the Regional Water Board approved a proposal to remove the nutrients listing, subject to State Water Board and U.S. EPA approval.

The discharge is not a significant source of chlordane, DDT, and dieldrin because these pollutants have not been detected in the discharge. The discharge is also not a source of exotic species because it is disinfected. It is an insignificant source of dioxins and furans, nickel, and selenium because discharge concentrations of these pollutants are consistently below water quality objectives or detection limits.

IV. RATIONALE FOR EFFLUENT LIMITATIONS AND DISCHARGE SPECIFICATIONS

The CWA requires point source dischargers to control the amount of conventional, non-conventional, and toxic pollutants discharged into waters of the United States. The control of pollutants discharged is established through effluent limitations and other requirements in NPDES permits. There are two principal bases for effluent limitations: 40 C.F.R. section 122.44(a) requires that permits include applicable technology-based limitations and standards; and 40 C.F.R. section 122.44(d) requires that permits include water quality-based effluent limitations to attain and maintain applicable numeric and narrative water quality criteria to protect the beneficial uses of receiving waters.

A. Discharge Prohibitions

- 1. Discharge Prohibition III.A (Discharge at a location or in a manner different from that described in this Order is prohibited):** This prohibition is based on 40 C.F.R. section 122.21(a) and Water Code section 13260, which require filing an application and Report of Waste Discharge before a discharge can occur. Discharges not described in the application and Report of Waste Discharge, and subsequently in this Order, are prohibited.
- 2. Discharge Prohibition III.B (Discharge is prohibited at Discharge Point Nos. 001 and 003 unless the river flow-to-effluent flow ratio is at least 10:1 and at Discharge Point No. 002 unless the river flow-to-effluent ration is at least 50:1):** This prohibition ensures that the discharge does not fully use the assimilative capacity of the Napa River in consideration of the other permitted wastewater discharges to this same segment of the river, specifically the City of St. Helena and the Town of Yountville, because all dischargers share the same receiving water monitoring for priority pollutants. Attachment F-1 to this Fact Sheet estimates that a ratio of at least 45:1 is necessary to ensure that assimilative capacity is available for all Napa River dischargers. These relatively simple calculations involve the following assumptions:
 - The mass of pollutants flowing downstream through the river equals the masses from each source flowing into the river;
 - Urban runoff flows are about 15 times the combined flows of the treatment plants discharging to the river; and

- Urban runoff copper loads are about eight times those of the wastewater discharges.

This prohibition also ensures that the river flow-to-effluent flow ratio is consistent with the underlying assumptions of the mixing zone study (*Effluent Mixing Zone / Dilution Credit Study*, Larry Walker Associates, April 2010) that serves as the basis for dilution credits used to analyze reasonable potential for non-priority pollutants (see Fact Sheet section IV.C.3.c) and to derive water quality-based effluent limits for others (see Fact Sheet section IV.C.4). This Order retains the 50:1 river flow-to-effluent flow ratio at Discharge Point No. 002 from the previous order to provide equivalent protection for shallow-water discharges of secondary-treated wastewater as discussed in Fact Sheet section IV.A.6, below.

- 3. Discharge Prohibition III.C (Bypass is prohibited):** This prohibition is based on 40 C.F.R. section 122.41(m) (see Attachment D section I.G).
- 4. Discharge Prohibition III.D (Average dry weather influent flow in excess of 0.84 MGD is prohibited):** This Order prohibits an average dry weather influent flow greater than 0.84 MGD because the plant design treatment capacity (i.e., its historic and tested treatment reliability) is 0.84 MGD. Exceeding this flow could result in lower reliability and greater potential to violate water quality requirements.
- 5. Discharge Prohibition III.E (Sanitary sewer overflows are prohibited):** Basin Plan Table 4-1, Discharge Prohibition 15, and the CWA prohibit the discharge of wastewater to surface waters, except as authorized under an NPDES permit. Publicly owned treatment works must achieve secondary treatment at a minimum and any more stringent limitations necessary to meet water quality standards (33 U.S.C. § 1311[b][1][B and C]). A sanitary sewer overflow that results in the discharge of raw sewage or wastewater not meeting this Order's effluent limitations to surface waters is therefore prohibited under the CWA and the Basin Plan.
- 6. Discharge Prohibition III.F (Discharge to Napa River is prohibited during dry season) and Exception to Non-Tidal Water Discharge Prohibition:** Basin Plan Table 4-1, Discharge Prohibition 1, prohibits discharges to any non-tidal water. Discharge Point Nos. 001, 002, and 003 discharge to the Napa River where the river is non-tidal. Discharge Prohibition III.F of this Order maintains Basin Plan Discharge Prohibition 1 during the dry season when it is feasible to not discharge (i.e., when treated wastewater can supply recycled water demand or be stored) and provides an exception when it is infeasible to not discharge (i.e., during wet weather when there is no recycled water demand or demand is low and the irrigation fields are saturated). Basin Plan section 4.2 provides for exceptions to Basin Plan Discharge Prohibition 1 under certain circumstances:
 - An inordinate burden would be placed on the Discharger relative to the beneficial uses protected, and an equivalent level of environmental protection can be achieved by alternate means;
 - A discharge is approved as part of a reclamation project;
 - Net environmental benefits will be derived as a result of the discharge; or
 - A discharge is approved as part of a groundwater cleanup project.

The Basin Plan further states:

Significant factors to be considered by the Regional Water Board in reviewing requests for exceptions will be the reliability of the discharger’s system in preventing inadequately treated wastewater from being discharged to the receiving water and the environmental consequence of such discharges.

This Order grants an exception to Basin Plan Discharge Prohibition 1 for the following reasons:

- At times, avoiding discharge to non-tidal waters is an inordinate burden. There is no feasible alternative to discharge when the irrigation field is saturated during wet weather. Regional Water Board Order No. 96-011 prohibits discharge to the Discharger’s irrigation fields when they are saturated. Moreover, the wastewater volume during these times can far exceed the storage capacity of the ponds.
- An equivalent level of protection is provided when the discharge receives tertiary treatment. An equivalent level of protection is provided when the discharge receives secondary treatment by compliance with a 50:1 river flow-to-effluent flow ratio at Discharge Point No. 002. The 50:1 river flow-to-effluent flow ratio for Discharge Point No. 002 also encourages maximum wastewater recycling and use of the plant’s tertiary treatment capacity, and limits secondary-treated discharge to its current level. The Discharger uses Discharge Point No. 002 only in response to peak wet weather events and only when capacity of the filters is exceeded. It used Discharge Point No. 002 just 16 days during the 2013/2014 discharge season and just 9 days during the 2014/2015 discharge season.

B. Conventional and Non-Conventional Pollutant Effluent Limitations

1. Scope and Authority

CWA section 301(b) and 40 C.F.R. section 122.44 require that permits include conditions meeting technology-based requirements, at a minimum, and any more stringent effluent limitations necessary to meet water quality standards. The discharges authorized by this Order must meet minimum federal technology-based requirements based on the Secondary Treatment Standards at 40 C.F.R. section 133 as summarized below. In addition, the 30-day average BOD₅ and TSS percent removal is not to be less than 85 percent. The Basin Plan contains additional requirements for certain pollutants.

Table F-6. Secondary Treatment Standards

Parameter	Monthly Average	Weekly Average
BOD ₅	30 mg/L	45 mg/L
TSS	30 mg/L	45 mg/L
pH	6.0 – 9.0 standard units	

Abbreviations:

- BOD₅ = biochemical oxygen demand (5 days at 20°C)
- TSS = total suspended solids
- mg/L = milligrams per liter

2. Effluent Limitations

- a. **BOD and TSS.** The BOD and TSS effluent limitations at Discharge Point No. 002 are based on the Secondary Treatment Standards and Basin Plan Table 4-2. Effluent data indicate that the Discharger consistently complies with these limits at Discharge Point No. 002.

The BOD and TSS effluent limitations at Discharge Point Nos. 001 and 003 are more stringent than those required by the Secondary Treatment Standards and Basin Plan Table 4-2. This higher level of treatment justifies, in part, an exception to Basin Plan Prohibition No. 1 (see Fact Sheet section IV.A.6). These limits are technologically feasible for advanced wastewater treatment technologies. Effluent data indicate that the Discharger consistently complies with these limits at Discharge Point No. 001. Effluent discharged at Discharge Point No. 003 should also consistently comply because it will receive the same treatment as that discharged at Discharge Point No. 001 (although it does not flow through the Riverside Ponds).

The TSS limits in this Order are more stringent than necessary to comply with the Napa River sediment TMDL (Basin Plan section 7.8.4). Basin Plan Table 7.8.4-3b (footnote a) states, “For wastewater treatment plant discharges, compliance with [an] existing permit effluent limit of 30 mg/L of TSS is consistent with these wasteload allocations.”

- b. **Oil and Grease.** The oil and grease effluent limitations are based on Basin Plan Table 4-2.
- c. **pH.** The pH effluent limitations are based on the Secondary Treatment Standards and Basin Plan Table 4-2.
- d. **Total Residual Chlorine.** The total residual chlorine effluent limitation is based on Basin Plan Table 4-2. This Order provides an allowance for determining false positives when using continuous devices based on the fact that continuous instruments occasionally have anomalous spikes and it is chemically improbable to have free chlorine present in the presence of sodium bisulfite. The allowance for using only on-the-hour measurements for mandatory minimum penalty assessment purposes under Water Code section 13385.1 is based on a 2004 strategy developed between the Regional Water Board and the Bay Area Clean Water Agencies.
- e. **Turbidity.** The turbidity effluent limitation at Discharge Point Nos. 001 and 003 is representative of adequate and reliable tertiary wastewater treatment. This limitation is a technologically feasible standard for the Discharger’s advanced wastewater treatment technologies and justifies, in part, an exception to Basin Plan Prohibition 1 (see Fact Sheet section IV.A.6). Effluent data indicate that the Discharger consistently complies with this limit at Discharge Point No. 001. Effluent discharged at Discharge Point No. 003 should also consistently comply because it will receive essentially the same treatment as that discharged at Discharge Point No. 001 (although it will not flow through the Riverside Ponds).
- e. **Total Coliform.** The total coliform effluent limitations are based on Basin Plan Table 4-2A, footnotes b and d. Footnote b allows total coliform limits in lieu of

enterococcus limits for intermittent discharges and discharges for which total coliform monitoring is required (e.g., at water recycling facilities). Footnote d allows exceptions to the limits listed in Table 4-2A as long as beneficial uses are not compromised and discharges do not exceed a five-sample median of 23 MPN/100 mL nor a maximum of 240 MPN/100 mL during dry weather. The total coliform limits are more stringent than the Napa River Pathogen TMDL requires (Basin Plan section 7.8.2 and Table 7.8.2-4 require a five-sample median less than 240 colony-forming units [CFU]/100 mL and a single-sample maximum of 10,000 CFU/100 mL).

C. Toxic Pollutant Effluent Limitations

1. Scope and Authority

For toxic pollutants, this Order contains water quality based effluent limitations (WQBELs) that implement water quality objectives protecting beneficial uses. CWA section 301(b) and 40 C.F.R. section 122.44(d) require that permits include limitations more stringent than federal technology-based requirements where necessary to achieve applicable water quality standards. According to 40 C.F.R. section 122.44(d)(1)(i), permits must include effluent limitations for all pollutants that are or may be discharged at levels that have a reasonable potential to cause or contribute to an exceedance of a water quality standard, including numeric and narrative objectives within a standard. Where reasonable potential has been established for a pollutant, but there is no numeric criterion or objective, WQBELs must be established using (1) U.S. EPA criteria guidance under CWA section 304(a), supplemented where necessary by other relevant information; (2) an indicator parameter for the pollutant of concern; or (3) a calculated numeric water quality criterion, such as a proposed state criterion or policy interpreting a narrative criterion, supplemented with relevant information (40 C.F.R. § 122.44[d][1][vi]). The process for determining reasonable potential and calculating WQBELs is intended to achieve applicable water quality objectives and criteria and protect beneficial uses of receiving waters as specified in the Basin Plan. This Order imposes numeric effluent limitations for toxic pollutants with reasonable potential to cause or contribute to exceedances of water quality standards.

2. Beneficial Uses and Water Quality Criteria and Objectives

Discharge Point Nos. 001, 002, and 003 discharge to the Napa River. Fact Sheet section III.C.1, above, identifies the beneficial uses of the Napa River. Water quality criteria and objectives to protect these beneficial uses are described below:

- a. Basin Plan Objectives.** The Basin Plan specifies numeric water quality objectives for many pollutants to protect aquatic life, municipal drinking water supplies, and agricultural water supplies (see Basin Plan sections 3.3.21 and 3.3.22). It also specifies several narrative water quality objectives, including objectives for toxicity, bioaccumulation, and temperature. The narrative toxicity objective states, “All waters shall be maintained free of toxic substances in concentrations that are lethal to or that produce other detrimental responses in aquatic organisms.” The narrative bioaccumulation objective states, “Controllable water quality factors shall not cause a detrimental increase in concentrations of toxic substances found in bottom sediments or aquatic life. Effects on aquatic organisms, wildlife, and human health will be considered.” The narrative temperature objective states, “The natural receiving water temperature of inland surface waters shall not be altered...,” and “The temperature of any

cold or warm freshwater habitat shall not be increased by more than 5°F (2.8°C) above natural receiving water temperature.”

- i. Agricultural Supply Pollutants.** The agricultural supply water quality objectives listed in Basin Plan Table 3-6 include threshold and limit concentrations. Pollutant effects are observable at threshold concentrations and undesirable at limit concentrations; therefore, the limit concentrations listed in Basin Plan Table 3-6 are the applicable water quality objectives for this Order.
- ii. Dioxins and Furans.** With respect to dioxins and furans, the narrative bioaccumulation objective is translated into a numeric criterion as follows. When the CTR was promulgated, U.S. EPA stated its support of the regulation of dioxin and dioxin-like compounds through the use of toxicity equivalencies (TEQs). U.S. EPA stated, “For California waters, if the discharge of dioxin or dioxin-like compounds has reasonable potential to cause or contribute to a violation of a narrative criterion, numeric WQBELs for dioxin or dioxin-like compounds should be included in NPDES permits and should be expressed using a TEQ scheme” (65 Fed. Reg. 31695-31696, May 18, 2000). This Order uses a TEQ scheme based on a set of toxicity equivalency factors (TEFs) the World Health Organization developed in 1998, and a set of bioaccumulation equivalency factors (BEFs) U.S. EPA developed for the Great Lakes region (40 C.F.R. part 132, Appendix F) to convert the concentration of any congener of dioxin or furan into an equivalent concentration of 2,3,7,8-tetrachlorinated dibenzo-p-dioxin (2,3,7,8-TCDD). Although the 1998 World Health Organization scheme includes TEFs for dioxin-like PCBs, they are not included in this Order’s TEQ scheme. The CTR has established a specific water quality criterion for PCBs, and dioxin-like PCBs are included in the analysis of total PCBs.

The CTR establishes a numeric water quality objective for 2,3,7,8-TCDD of 1.4×10^{-8} µg/L for the protection of human health when aquatic organisms are consumed. The CTR criterion is used as a criterion for dioxin-TEQ because dioxin-TEQ represents a toxicity-weighted concentration equivalent to 2,3,7,8-TCDD, thus translating the narrative bioaccumulation objective into a numeric criterion.

- iii. Total Ammonia.** Basin Plan section 3.3.20 contains water quality objectives for un-ionized ammonia of 0.025 mg/L as an annual median and 0.16 mg/L as a maximum for Central San Francisco Bay and upstream waters. Using the receiving water temperature, salinity levels, and pH concentrations as explained below, these un-ionized ammonia objectives translate to chronic total ammonia criteria of 5.0 mg/L as nitrogen (N) and an acute total ammonia objective of 14 mg/L as N. Translation to total ammonia is necessary because (1) sampling and laboratory methods are unavailable to analyze for un-ionized ammonia, and (2) the fraction of total ammonia that exists in the toxic un-ionized form varies with the pH, salinity, and temperature of the receiving water.

To translate the un-ionized ammonia objectives, pH, salinity, and temperature data were obtained from the Napa River upstream from the plant. The un-ionized fraction of total ammonia was calculated as follows:

$$\text{For salinity} < 10 \text{ ppt: fraction of NH}_3 = \frac{1}{1 + 10^{(pK - pH)}}$$

Where:

$$pK = 0.09018 + \frac{2,729.92}{T}$$

T = Temperature (degrees Kelvin)

The median and 90th percentile un-ionized ammonia fractions were then used to express the daily maximum and the annual average un-ionized objectives as chronic and acute total ammonia criteria. This approach is consistent with U.S. EPA guidance on translating dissolved metal water quality objectives to total recoverable metal water quality objectives (U.S. EPA, 1996, *The Metals Translator: Guidance for Calculating a Total Recoverable Limit from a Dissolved Criterion*, EPA Publication 823-B-96-007).

- iv. Chronic Toxicity.** Basin Plan section 3.3.18 states, “There shall be no chronic toxicity in ambient waters. Chronic toxicity is a detrimental biological effect on growth rate, reproduction, fertilization success, larval development, population abundance, community composition, or any other relevant measure of the health of an organism, population, or community. Attainment of this objective will be determined by analyses of indicator organisms, species diversity, population density, growth anomalies, or toxicity tests..., or other methods selected by the Water Board.”

This Order uses 1.0 chronic toxicity unit (TUc) as a numeric water quality criterion for chronic toxicity. This is a direct translation of the narrative chronic toxicity objective because 1.0 TUc indicates no observable detrimental effect to an indicator organism exposed to 100 percent effluent in a bioassay. Moreover, U. S. EPA’s *Technical Support Document for Water Quality-based Toxics Control* (EPA/505/2-90-001) (Technical Support Document) recommends 1.0 TUc as a criterion continuous concentration (typically a four-day average). It further states that reasonable potential is shown where an effluent is projected to cause an excursion above the criterion continuous concentration. The Technical Support Document is applicable here as guidance because it directly addresses effluent characterization for whole effluent toxicity.

- b. CTR Criteria.** The CTR specifies numeric aquatic life and human health criteria for numerous priority pollutants. These criteria apply to inland surface waters and enclosed bays and estuaries. Some human health criteria are for consumption of “water and organisms” and others are for consumption of “organisms only.” The criteria applicable to “water and organisms” apply to the Napa River because it is a potential source of drinking water.
- c. NTR Criteria.** The NTR establishes numeric aquatic life and human health criteria for a number of toxic pollutants for San Francisco Bay waters upstream to and including Suisun Bay and the Sacramento-San Joaquin Delta. The NTR criteria apply to the Napa River.

- d. **Receiving Water Salinity.** The Napa River is a freshwater river in the vicinity of the discharge. As confirmed by the Collaborative Napa River Receiving Water Evaluation (2003), Napa River salinity in all samples upstream and downstream of the discharge falls below one part per thousand, indicating a freshwater environment. Therefore, the freshwater water quality objectives from the Basin Plan, NTR, and CTR apply to this discharge.
- e. **Receiving Water Hardness.** Ambient hardness data were used to calculate freshwater water quality objectives that are hardness dependent. Hardness was measured upstream of the discharge 34 times between December 2010 and April 2015. The geometric mean of these results, 59 mg/l as calcium carbonate, was used to calculate the water quality objectives.
- f. **Site-Specific Metals Translators.** Effluent limitations for metals must be expressed as total recoverable metal (40 C.F.R. § 122.45[c]). Since the water quality objectives for metals are typically expressed as dissolved metal, translators must be used to convert metals concentrations from dissolved to total recoverable and vice versa. The CTR contains default translators; however, site-specific conditions, such as water temperature, pH, TSS, and organic carbon may affect the form of metal (dissolved, non-filterable, or otherwise) present and therefore available to cause toxicity. In general, dissolved metals are more available and more toxic to aquatic life than other forms. Site-specific translators can account for site-specific conditions, thereby preventing overly stringent or under-protective water quality objectives. In determining the need for and calculating WQBELs for all applicable metals, CTR default translators were used.

3. Need for Water Quality-Based Effluent Limitations (Reasonable Potential Analysis)

Assessing whether a pollutant has reasonable potential to exceed a water quality objective is the fundamental step in determining whether a WQBEL is required.

- a. **Available Information.** The reasonable potential analysis for this Order is based on effluent monitoring data the Discharger collected from December 2010 through May 2015. The analysis is also based on ambient data collected collaboratively by the Discharger and other dischargers to the Napa River at a location approximately 1,000 feet upstream of Discharge No. 001 (this location was selected to represent ambient background quality in the *Collaborative Napa River Receiving Water Evaluation*, March 5, 2003). These data were collected in February and April 2002, April 2007, April 2008, February 2009, May 2013, and March 2015.

In some cases, reasonable potential cannot be determined because effluent data are limited or ambient background concentrations are unavailable. Provision VI.C.2 of this Order requires the Discharger to continue monitoring for such constituents in its effluent using analytical methods that provide the best feasible detection limitations. When additional data become available, further analysis will be conducted to determine whether numeric effluent limitations are necessary.

This Order does not contain WQBELs for constituents that do not demonstrate reasonable potential; however, Provision VI.C.2 of this Order still requires monitoring for such pollutants. If concentrations are found to have increased significantly, Provision VI.C.2

of this Order requires the Discharger to investigate the sources of the increases and implement remedial measures if the increases pose a threat to receiving water quality.

b. Priority Pollutants. For the priority pollutants, the reasonable potential analysis for this Order is based on the methodology set forth in SIP section 1.3. Dioxin-TEQ is included because the bioaccumulation objective is intended to protect aquatic life and human health similar to the priority pollutant objectives. The analysis begins with identifying the maximum effluent concentration (MEC) observed for each pollutant based on available effluent concentration data and the ambient background concentration (B). SIP section 1.4.3 states that ambient background concentrations are either the maximum ambient concentration observed or, for water quality objectives intended to protect human health, the arithmetic mean of observed concentrations. There are three triggers in determining reasonable potential:

- i. Trigger 1** is activated if the MEC is greater than or equal to the lowest applicable water quality objective ($MEC \geq$ water quality objective).
- ii. Trigger 2** is activated if the ambient background concentration observed in the receiving water is greater than the lowest applicable water quality objective ($B >$ water quality objective) *and* the pollutant is detected in any effluent sample.
- iii. Trigger 3** is activated if a review of other information indicates that a WQBEL is needed to protect beneficial uses.

The MECs, most stringent applicable water quality criteria and objectives, and background concentrations used in the analysis are presented below, along with the reasonable potential analysis results (yes or no) for each pollutant. The pollutants that exhibit reasonable potential are antimony, copper, cyanide, chlorodibromomethane, and dichlorobromomethane by Trigger 1.

Table F-7. Priority Pollutant Reasonable Potential Analysis

CTR No.	Pollutants	C or Governing Criterion or Objective (µg/L)	MEC or Minimum DL (µg/L) ^{[1][2]}	B or Minimum DL (µg/L) ^{[1][2]}	RPA Results ^[3]
1	Antimony	6.0	45	1.8	Yes
2	Arsenic	50	24	4.3	No
3	Beryllium	4.0	0.080	0.060	No
4	Cadmium	0.75	0.030	<0.020	No
5a	Chromium (III)	50	---	1.8	No
5b	Chromium (VI)	11	0.39	<0.15	No
6	Copper	5.9	10	3.1	Yes
7	Lead	1.6	0.39	1.1	No
8	Mercury (303(d) listed) ^[4]	---	---	---	---
9	Nickel	33	2.4	4.1	No
10	Selenium (303(d) listed)	5.0	0.43	3.0	No
11	Silver	1.6	0.020	0.030	No
12	Thallium	1.7	<0.040	0.20	No
13	Zinc	77	43	12	No
14	Cyanide	5.2	6.9	<0.60	Yes

CTR No.	Pollutants	C or Governing Criterion or Objective (µg/L)	MEC or Minimum DL (µg/L) ^{[1][2]}	B or Minimum DL (µg/L) ^{[1][2]}	RPA Results ^[3]
16	2,3,7,8-TCDD	1.3 E-08	<4.7E-07	<6.3E-07	U
	Dioxin-TEQ	1.4 E-08	3.6E-11	1.3E-11	No
17	Acrolein	320	<1.7	<1.2	No
18	Acrylonitrile	0.059	<0.69	<0.58	U
19	Benzene	1.0	<0.18	<0.10	No
20	Bromoform	4.3	0.90	<0.090	No
21	Carbon Tetrachloride	0.25	<0.16	<0.060	No
22	Chlorobenzene	70	<0.18	<0.10	No
23	Chlorodibromomethane	0.41	9.1	<0.080	Yes
24	Chloroethane	No Criteria	<0.38	<0.11	U
25	2-Chloroethylvinyl ether	No Criteria	<0.28	<0.28	U
26	Chloroform	No Criteria	41	0.47	U
27	Dichlorobromomethane	0.56	22	<0.080	Yes
28	1,1-Dichloroethane	5.0	<0.19	<0.060	No
29	1,2-Dichloroethane	0.38	<0.18	<0.090	No
30	1,1-Dichloroethylene	0.057	<0.21	<0.070	U
31	1,2-Dichloropropane	0.52	<0.18	<0.070	No
32	1,3-Dichloropropylene	0.50	<0.16	<0.070	No
33	Ethylbenzene	300	<0.26	<0.090	No
34	Methyl Bromide	48	0.40	<0.060	No
35	Methyl Chloride	No Criteria	<0.23	<0.090	U
36	Methylene Chloride	4.7	<0.20	<0.080	No
37	1,1,2,2-Tetrachloroethane	0.17	<0.10	<0.070	No
38	Tetrachloroethylene	0.80	<0.19	<0.12	No
39	Toluene	150	<0.19	<0.060	No
40	1,2-Trans-Dichloroethylene	10	<0.22	<0.090	No
41	1,1,1-Trichloroethane	200	<0.19	<0.11	No
42	1,1,2-Trichloroethane	0.60	<0.16	<0.060	No
43	Trichloroethylene	2.7	<0.20	<0.070	No
44	Vinyl Chloride	0.50	<0.25	<0.14	No
45	2-Chlorophenol	120	<0.70	<0.40	No
46	2,4-Dichlorophenol	93	<0.90	<0.30	No
47	2,4-Dimethylphenol	540	<0.80	<0.30	No
48	2-Methyl- 4,6-Dinitrophenol	13	<0.60	<0.40	No
49	2,4-Dinitrophenol	70	<0.90	<0.30	No
50	2-Nitrophenol	No Criteria	0.0	<0.30	U
51	4-Nitrophenol	No Criteria	0.0	<0.20	U
52	3-Methyl 4-Chlorophenol	No Criteria	0.0	<0.30	U
53	Pentachlorophenol	0.28	<0.0050	<0.0050	No
54	Phenol	21,000	0.83	0.34	No
55	2,4,6-Trichlorophenol	2.1	<0.97	<0.20	No
56	Acenaphthene	1,200	<0.016	<0.016	No
57	Acenaphthylene	No Criteria	<0.014	<0.014	U
58	Anthracene	9,600	<0.019	0.020	No
59	Benzidine	0.00012	<5.0	<0.30	U

CTR No.	Pollutants	C or Governing Criterion or Objective (µg/L)	MEC or Minimum DL (µg/L) ^{[1][2]}	B or Minimum DL (µg/L) ^{[1][2]}	RPA Results ^[3]
60	Benzo(a)Anthracene	0.0044	<0.011	<0.011	U
61	Benzo(a)Pyrene	0.0044	<0.011	<0.011	U
62	Benzo(b)Fluoranthene	0.0044	<0.011	<0.011	U
63	Benzo(ghi)Perylene	No Criteria	<0.012	<0.012	U
64	Benzo(k)Fluoranthene	0.0044	<0.017	<0.017	U
65	Bis(2-Chloroethoxy)Methane	No Criteria	---	<0.30	U
66	Bis(2-Chloroethyl)Ether	0.031	<0.70	<0.30	No
67	Bis(2-Chloroisopropyl)Ether	1,400	<0.60	<0.60	No
68	Bis(2-Ethylhexyl)Phthalate	1.8	---	0.60	U
69	4-Bromophenyl Phenyl Ether	No Criteria	---	<0.50	U
70	Butylbenzyl Phthalate	3,000	<0.063	<0.063	No
71	2-Chloronaphthalene	1,700	0	<0.30	No
72	4-Chlorophenyl Phenyl Ether	No Criteria	0	<0.40	U
73	Chrysene	0.0044	<0.014	<0.020	U
74	Dibenzo(a,h)Anthracene	0.0044	<0.033	<0.020	U
75	1,2-Dichlorobenzene	600	<0.27	<0.11	No
76	1,3-Dichlorobenzene	400	<0.18	<0.11	No
77	1,4-Dichlorobenzene	5.0	<0.18	<0.10	No
78	3,3 Dichlorobenzidine	0.040	<5.0	<0.40	U
79	Diethyl Phthalate	23,000	<0.051	<0.051	No
80	Dimethyl Phthalate	313,000	<0.039	<0.039	No
81	Di-n-Butyl Phthalate	2,700	<0.074	<0.074	No
82	2,4-Dinitrotoluene	0.11	<0.013	<0.013	No
83	2,6-Dinitrotoluene	No Criteria	<0.036	<0.036	U
84	Di-n-Octyl Phthalate	No Criteria	<0.027	<0.027	U
85	1,2-Diphenylhydrazine	0.040	<0.70	<0.30	U
86	Fluoranthene	300	<0.010	<0.010	No
87	Fluorene	1,300	<0.014	<0.030	No
88	Hexachlorobenzene	0.00075	<0.041	<0.041	U
89	Hexachlorobutadiene	0.44	<0.60	<0.20	No
90	Hexachlorocyclopentadiene	50	0.14	<0.038	No
91	Hexachloroethane	1.9	<0.60	<0.20	No
92	Indeno(1,2,3-cd)Pyrene	0.0044	<0.027	<0.020	U
93	Isophorone	8.4	<0.020	<0.020	No
94	Naphthalene	No Criteria	<0.014	<0.014	U
95	Nitrobenzene	17	<0.90	<0.30	No
96	N-Nitrosodimethylamine	0.00069	<0.50	<0.40	U
97	N-Nitrosodi-n-Propylamine	0.0050	<0.80	<0.30	U
98	N-Nitrosodiphenylamine	5.0	<0.50	<0.40	No
99	Phenanthrene	No Criteria	<0.0080	0.040	U
100	Pyrene	960	<0.0080	<0.0080	No
101	1,2,4-Trichlorobenzene	5.0	<0.60	<0.30	No
102	Aldrin	0.00013	<0.0040	<0.0020	U
103	Alpha-BHC	0.0039	<0.0050	<0.0020	U
104	Beta-BHC	0.014	<0.0040	<0.0010	No

CTR No.	Pollutants	C or Governing Criterion or Objective (µg/L)	MEC or Minimum DL (µg/L) ^{[1][2]}	B or Minimum DL (µg/L) ^{[1][2]}	RPA Results ^[3]
105	Gamma-BHC	0.019	<0.0040	<0.0010	No
106	Delta-BHC	No Criteria	<0.0040	<0.0010	U
107	Chlordane (303(d) listed)	0.00057	<0.0050	<0.0050	U
108	4,4'-DDT (303(d) listed)	0.00059	<0.0040	<0.0010	U
109	4,4'-DDE (linked to DDT)	0.00059	<0.0030	<0.0010	U
110	4,4'-DDD	0.00083	<0.0040	<0.0010	U
111	Dieldrin (303d listed)	0.00014	<0.0040	<0.0020	U
112	Alpha-Endosulfan	0.056	<0.0040	<0.0030	No
113	beta-Endosulfan	0.056	<0.0050	<0.0010	No
114	Endosulfan Sulfate	110	<0.0050	<0.0010	No
115	Endrin	0.036	<0.0050	<0.0020	No
116	Endrin Aldehyde	0.76	<0.0050	<0.0020	No
117	Heptachlor	0.00021	<0.0030	<0.0030	U
118	Heptachlor Epoxide	0.00010	<0.0040	<0.0020	U
119-125	PCBs sum (303(d) listed) ^[4]	0.00017	---	---	U
126	Toxaphene	0.00020	<0.083	<0.083	U

Footnotes:

- ^[1] The maximum effluent concentration and ambient background concentration are the actual detected concentrations unless preceded by a “<” sign, in which case the value shown is the minimum detection level (DL).
- ^[2] The maximum effluent concentration or ambient background concentration is “Unavailable” when there are no monitoring data for the constituent.
- ^[3] RPA Results = Yes, if MEC ≥ WQC, B > WQC and MEC is detected, or Trigger 3
 = No, if MEC and B are < WQC or all effluent data are undetected
 = Unknown, cannot determine (U), if no criteria have been promulgated or data are insufficient.
- ^[4] SIP section 1.3 excludes from its reasonable potential analysis procedure priority pollutants for which a TMDL has been developed. TMDLs have been developed for mercury and PCBs in San Francisco Bay. Mercury and PCBs from wastewater discharges are regulated by NPDES Permit No. CA0038849, which implements the San Francisco Bay Mercury and PCBs TMDLs.
- ^[5] The units for ammonia are milligrams per liter as nitrogen.

c. Municipal and Agricultural Supply Pollutants. The reasonable potential analysis for municipal and agricultural supply pollutants concludes that there is reasonable potential for boron. Municipal and agricultural supply are beneficial uses of the Napa River. For water quality objectives designed to protect municipal and agricultural supply (see Basin Plan Tables 3-5 and 3-6), except for those already analyzed in Table F-7, the reasonable potential analysis is based on the Technical Support Document. The Technical Support Document allows reasonable potential analyses using either receiving water concentrations projected from effluent data or measured receiving water concentrations. The analysis presented in Table F-8 uses receiving water concentrations projected from effluent data in accordance with the procedure described below.

i. Technical Support Document Procedure. The Technical Support Document reasonable potential analysis procedure using receiving water concentrations projected from effluent data is summarized below:

Step 1. Determine the total number of observations (n) and the highest value (the maximum effluent concentration or MEC) in the effluent data set.

Step 2. Determine the coefficient of variation (CV) of the data set. If $n < 10$, use a CV of 0.6; if $n \geq 10$, use a CV equal to the standard deviation of the data set divided by its mean.

Step 3. Determine a ratio (R) for projecting an upper bound concentration based on a selected confidence interval (e.g., 95 percent) and assuming a lognormal distribution as follows:

Determine the percentile represented by the MEC in the data set (P_n) based on the selected confidence interval.

$$P_n = (1 - \text{confidence interval})^{1/n}$$

Calculate C_{P_n} and $C_{\text{upper bound}}$ corresponding to P_n and the selected upper bound percentile (typically the 95th or 99th percentile) using the following equation:

$$C_P = \exp(Z_P\sigma - 0.5\sigma^2)$$

Where: $\sigma^2 = \ln(\text{CV}^2 + 1)$

P is the percentile (either P_n or $P_{\text{upper bound}}$ percentile)

Z_p is the standard normal distribution value for the percentile P (available from statistical references)

Finally, calculate R as:

$$R = C_{\text{upperbound}}/C_{P_n}$$

Step 4. Calculate the projected maximum receiving water concentration (RWC) as follows:

$$\text{RWC} = (\text{MEC} \times R) / \text{dilution ratio}$$

The dilution ratio can be defined as:

$$\text{dilution ratio} = \frac{(D + [1 \text{ part effluent}])}{[1 \text{ part effluent}]}$$

Where: D is the parts receiving water available to dilute 1 part effluent

Therefore:

$$\text{RWC} = (\text{MEC} \times R) / (D + 1)$$

Step 5. Compare the RWC to the water quality objectives. There is reasonable potential if the RWC is greater than or equal to a water quality objective.

- ii. Mixing Zones and Dilution.** The Technical Support Document allows mixing zones and dilution to be considered when projecting receiving water concentrations. The Discharger's mixing zone study (*City of Calistoga Effluent Mixing Zone / Dilution Credit Study*, Larry Walker Associates, Inc., April 2010) indicates that the effluent plume is fully mixed vertically and laterally no more than 120 feet downstream from Discharge Point No. 001 at a river flow-to-effluent flow ratio of 10:1. Discharge

Prohibition III.B maintains a minimum 10:1 river-to-effluent flow ratio for tertiary-treated effluent and a much larger ratio of 50:1 for secondary-treated effluent. The Napa River is unlikely to be directly tapped for municipal or agricultural use, but Napa River flow is important to recharge groundwater, which is, in fact, tapped for municipal and agricultural supply. Before being used for these purposes, however, plant effluent will thoroughly mix with Napa River water. At least 10:1 dilution is therefore assumed to occur. The following analysis assumes a river flow-to-effluent flow ratio of 10:1 ($D = 9$) to calculate the RWC.

iii. Analysis. The number of samples for the pollutants listed in Table F-8 range from 1 to 795. The following example is based on the boron effluent data, where $n=6$.

Using a 95 percent confidence interval, P_n is:

$$P_{0.61} = (1 - 0.95)^{1/6} = 0.61$$

For a normal distribution, the Z-score for 0.61 (i.e., the 61st percentile) is:

$$Z_{0.61} = 0.27$$

Since $n < 10$, the CV is assumed to be 0.6 and $\sigma^2 = 0.31$. Therefore, based on a 99th percentile upper bound, R is calculated as follows:

$$C_{0.61} = \exp(Z_{0.61} \sigma - 0.5 \sigma^2) = \exp(0.27 * 0.55 - 0.5 * 0.31) = 1.0$$

$$C_{upperbound} = C_{0.99} = \exp(Z_{0.99} \sigma - 0.5 \sigma^2) = \exp(2.3 * 0.55 - 0.5 * 0.31) = 3.1$$

$$R = \frac{C_{upperbound}}{C_{P_n}} = \frac{3.1}{1.0} = 3.1$$

Since $R = 3.1$, the MEC for boron is 3,100 mg/L, and $D = 9$ (i.e., the dilution ratio is 10:1), the projected maximum RWC for boron is:

$$RWC = MEC \times R / (D + 1) = 970 \text{ mg/L}$$

The boron RWC does not exceed the boron water quality objective for agricultural supply (2,000 $\mu\text{g/L}$); therefore, this analysis based on the Technical Support Document does not demonstrate reasonable potential. However, this analysis does not account for ambient boron in the receiving water, which reduces the assimilative capacity of the receiving water to dilute boron in the discharge. The highest ambient boron concentration measured (1,500 $\mu\text{g/L}$) is quite close to the water quality objective. In addition, boron may be of particular concern for vineyards (Ayers, R. S. and D. W. Westcot, Water Quality for Agriculture, Food and Agriculture Organization of the United Nations - Irrigation and Drainage Paper No. 29, Rev. 1, Rome, 1985), which are widespread throughout the Napa Valley. Based on this additional information, reasonable potential is found.

For the pollutants with water quality objectives designed to protect municipal and agricultural supply, except those already analyzed in Table F-7, the table below presents the most stringent applicable water quality objectives, MECs, and calculated

RWCs, along with the reasonable potential analysis results (yes or no) for each pollutant

Table F-8. Municipal and Agricultural Supply Pollutant Reasonable Potential Analysis

Pollutant	Governing Criterion or Objective (µg/L)	MEC or Minimum DL (µg/L) ^[1]	RWC (µg/L) ^[1]	RPA Results ^[2]
Color (color units)	15	---	---	---
Turbidity (NTU)	5.0	4.7	0.37	No
Total Dissolved Solids	500,000	770,000	92,000	No
Electrical Conductivity (mmhos/cm)	900	---	---	---
Aluminum	200	70	43	No
Barium	1,000	16	10	No
Boron	2,000	3,100	970	Yes
Chloride	250,000	130,000	79,000	No
Cobalt	5,000	0.10	0.061	No
Fluoride	600	3,000	460	No
Iron	300	20	12	No
Lithium	2,500	520	320	No
Manganese	50	3.7	2.3	No
Molybdenum	50	2.1	1.3	No
Nitrate (as NO ₃)	45,000	9,500	3,600	No
Nitrate + Nitrite (as N)	10,000	23,000	1,300	No ^[3]
Nitrite (as N)	1,000	---	---	---
Sulfate	250,000	120,000	66,000	No
Vanadium	1,000	2.5	1.5	No
MBAS (foaming agents)	500	67	41	No
Phenols	1.0	0.83	0.51	No
Trihalomethanes	100	---	---	---
Lindane	0.20	---	---	---
Methoxychlor	30	<0.0050	<0.0017	No
2,4-D	70	<0.028	<0.017	No
2,4,4-TP Silvex	50	<0.020	<0.012	No
Alachlor	2.0	<0.022	<0.012	No
Atrazine	1.0	<0.048	<0.029	No
Bentazon	18	<0.063	<0.038	No
Dalapon	200	<0.12	<0.074	No
Dinoseb	7.0	<0.024	<0.015	No
Diquat	20	<0.34	<0.21	No
Endothall	100	<2.7	<1.6	No
Ethylene dibromide	0.050	<0.0057	<0.0035	No
Glyphosate	700	<1.6	<0.98	No
Molinate	20	<0.015	<0.0092	No
Oxarnyl	50	<0.40	<0.24	No
Picloram	500	---	---	---
Simazine	4.0	<0.028	<0.017	No
Thiobencarb	1.0	<0.0080	<0.0044	No

Pollutant	Governing Criterion or Objective (µg/L)	MEC or Minimum DL (µg/L) ^[1]	RWC (µg/L) ^[1]	RPA Results ^[2]
1,2-dibromo-3-chloropropane	0.20	---	---	---
Cis-1,2-dichloroethylene	6.0	<0.20	<0.068	No
Methyl-tert-butyl ether	5.0	<0.15	<0.051	No
Monochlorobenzene	70	---	---	---
Styrene	100	---	---	---
Trichlorofluoromethane	150	<0.29	<0.16	No
1,1,2-trichloro-1,2,2-trifluoromethane	1,200	---	---	---

Footnotes:

- ^[1] The maximum effluent concentration and ambient background concentration are the actual detected concentrations unless preceded by a “<” sign, in which case the value shown is the minimum detection level (DL).
- ^[2] RPA Results = Yes, if RWC ≥ WQC
= No, if RWC < WQC or all effluent data are undetected
- ^[3] The projected nitrate and nitrite receiving water concentration is somewhat close to the governing objective; however, actual receiving water concentrations are less than the governing objective. The Technical Support Document allows reasonable potential analyses to be based on actual receiving water data. In this case, Napa River monitoring data available supplied from the Discharger shows that the highest nitrate and nitrite concentration in the Napa River was 1,300 µg/L (sampled on January 6, 2015), which is less than the objective of 5,000 µg/L.

d. Ammonia. Reasonable potential for ammonia was evaluated based on Technical Support Document procedures for projecting a receiving water concentration from effluent data. Fact Sheet sections IV.C.3.c.i and iii describe this procedure. For a conservative analysis, zero dilution was assumed (i.e., D = 0).

Twenty-four ammonia effluent samples were collected between January 2012 and April 2015. Based on n = 24, P_n at a 95 percent confidence interval is:

$$P_{24} = (1 - 0.95)^{1/24} = 0.88$$

For a normal distribution, the 95-percent confidence interval Z-score for 0.88 (i.e., the 0.88th percentile) is:

$$Z_{0.88} = 1.2$$

The standard deviation of un-ionized ammonia values is 0.031 mg/L and the mean is 0.022 mg/L; therefore, the CV is 1.4 and σ² = 1.1. Therefore, based on a 99th percentile upper bound, R is calculated as follows:

$$C_{Pn} = C_{0.88} = \exp(Z_{0.88}\sigma - 0.5\sigma^2) = \exp(1.2 * 1.0 - 0.5 * 1.1) = 2.0$$

$$C_{upperbound} = C_{0.99} = \exp(Z_{0.99}\sigma - 0.5\sigma^2) = \exp(2.3 * 1.0 - 0.5 * 1.1) = 6.5$$

$$R = \frac{C_{upperbound}}{C_{Pn}} = \frac{6.5}{2.0} = 3.2$$

Since R=3.2, the MEC for un-ionized ammonia is 0.099 mg/L, and D = 0, the projected maximum RWC for un-ionized ammonia is:

$$RWC = MEC \times R / (D + 1) = 0.32 \text{ mg/L}$$

This RWC is greater than the acute water quality objective (0.016 mg/L) and the chronic water quality objective (0.025 mg/L), indicating reasonable potential for ammonia to exceed water quality objectives.

- e. **Temperature.** Basin Plan section 3.3.17 prohibits temperature increases greater than 2.8°C above natural receiving water temperatures, and alteration of natural receiving water temperatures such that beneficial uses are adversely affected. Receiving water monitoring from January 2012 through April 2015 showed no temperature difference between the upstream and downstream monitoring stations greater than or equal to 2.8°C (while the effluent temperature is about 5°C higher than the receiving water temperature, the effluent flow is significantly less than the river flow). Therefore, there is no reasonable potential for the Discharge to exceed the Basin Plan temperature water quality objective.
- f. **Acute Toxicity.** Basin Plan section 4.5.5.3.1 requires acute toxicity monitoring and limitations, implying there is reasonable potential for the discharge to cause or contribute to exceedances of the acute toxicity water quality objective.
- g. **Chronic Toxicity.** This Order translates the Basin Plan’s narrative chronic toxicity objective by using 1.0 TUc as a numeric water quality criterion. The previous order required annual chronic toxicity tests at Monitoring Locations EFF-001 and EFF-002 using the water flea (*Ceriodaphnia dubia*) as the test organism. Chronic toxicity exceeded 1.0 TUc at Monitoring Location EFF-001 in zero out of five tests using organism survival as the test endpoint and in two out of five tests using reproduction inhibition as the test endpoint. The highest result, 2.2 TUc, occurred in March 2012.

For chronic toxicity, Basin Plan 4.5.5.3.2 states, “[allow] credit for dilution comparable to those allowed for numeric chemical specific objectives, effluent variability, and intent to protect against consistent chronic toxicity and severe episodic toxic events.” For this reason, this Order authorizes a mixing zone for chronic toxicity corresponding to a dilution credit of 4:1 (D = 3). This dilution credit is within the range of D = 3 to 5 granted for other pollutants with water quality objectives intended to protect aquatic life (see Fact Sheet section IV.C.4.b).

Since the MEC for chronic toxicity is 2.2 TUc and D = 3, the maximum RWC for chronic toxicity is:

$$\text{RWC} = \text{MEC} / \text{D} = 0.73 \text{ TUc}$$

Because the projected maximum receiving water toxicity of 0.73 TUc is less than the numeric criterion of 1.0 TUc, there is no reasonable potential.

4. Water Quality-Based Effluent Limitations (WQBELs)

WQBELs were developed for the pollutants determined to have reasonable potential to cause or contribute to exceedances of water quality objectives. The WQBELs are based on the procedure specified in SIP section 1.4, which is required for priority pollutants. SIP section 1.4 is used as guidance for other pollutants.

- a. Mixing Zones and Dilution.** The SIP allows dilution credits for completely-mixed discharges and, under certain circumstances, for incompletely-mixed discharges. The Discharger's April 2010 mixing zone study (*City of Calistoga Effluent Mixing Zone/Dilution Credit Study*, Larry Walker Associates, Inc., April 2010) indicates that the discharge is incompletely-mixed as defined by the SIP (more than 5 percent difference in pollutant concentrations in a cross section of the river within two river widths downstream).

None of the Facility's three outfalls have a diffuser, and all three are located on the north bank of the Napa River. Discharge Point No. 001 is a 30-inch diameter circular pipe with an open end extending four feet from the north bank of the river and raised six feet from the channel bottom. Discharge Point No. 002 is a 10-inch diameter circular pipe with a heavy-gage metal flap valve to prevent backflow. The pipe opens into a semi-enclosed, concrete outlet level with the channel bottom. Discharge Point No. 003 is planned to incorporate an existing 18-inch diameter circular pipe extending two feet from the north bank and raised four feet from the channel bottom. The existing pipe also has a heavy-gauge metal flap to prevent backflow and opens into a semi-enclosed, concrete outlet. Effluent from these outfalls projects laterally from the north bank into the river channel, but does not reach the opposite bank.

The mixing zone study consisted of a tracer study conducted on discharge from Discharge Point No. 001 on December 21, 2009, and simulation modeling using the U.S. EPA-supported CORMIX model. CORMIX was calibrated based on the results of the tracer study. CORMIX was then used to estimate mixing zone size based on the point where the plume is fully vertically and laterally mixed and achieves 10:1 dilution. (The discharger provided updated CORMIX model output for discharges from Discharge Point No. 003.) The CORMIX results vary under different critical river flow conditions and for the discharges from each outfall. In many cases, the mixing zones this Order authorizes are much smaller than those based on full 10:1 dilution.

The largest possible mixing zone during any four days is 410 feet long by 15 feet wide for Discharge Point No. 001, 43 feet long by 5 feet wide for Discharge Point No. 002, and 500 feet long by 19 feet wide for Discharge Point No. 003. These conditions occur during maximum four-day average effluent flows when the effluent flows at Discharge Point Nos. 001 and 003 are 10 percent of the river flow and when the effluent flow at Discharge Point No. 002 is 2 percent of the river flow.

The largest possible mixing zone for long-term average effluent flow conditions is 530 feet long by 12 feet wide for Discharge Point No. 001, 8 feet long by 7 feet wide for Discharge Point No. 002, and 330 feet long by 13 feet wide for Discharge Point No. 003. In all cases, the plume extends laterally from the bank but stays attached to the bank nearest the discharge. These conditions occur at the long-term average effluent flow and a river flow-to-effluent flow ratio of 10:1 at Discharge Point Nos. 001 and 003 and a river flow-to-effluent flow ratio of 50:1 at Discharge Point No. 002.

This Order grants mixing zones for antimony, boron, cyanide, copper, chlorodibromomethane, dichlorobromomethane, and ammonia, and uses a mixing zone in the reasonable potential analysis as described above for other parameters that are not also priority pollutants. In accordance with SIP section 1.4.2.2.A, mixing zones extending up

to 530 feet from Discharge Point No. 001, up to 43 feet from Discharge Point No. 002, and up to 500 feet from Discharge Point No. 003 meet the following requirements:

- i. No compromise to the integrity of the water body.** The mixing zones will not compromise the integrity of the Napa River because they are small relative to the size of the Napa River and do not extend across its entire width. The mixing zones are no longer than 530 feet in length, which is less than one percent of the 55-mile length of the Napa River. At their greatest estimated sizes (i.e., assuming the greatest volume permitted by the 10:1 river flow-to-effluent flow ratio is discharged), the mixing zones for Discharge Point Nos. 001 and 002 allow at least two-thirds of the river cross-section as a zone of passage for aquatic organisms. The mixing zones for Discharge Point No. 003 allow at least nine percent of the river cross-section at 10:1 dilution for passage of aquatic organisms; however, the mixing zones for pollutants with limits based on aquatic toxicity (i.e., that would actually tend to restrict passage of aquatic organisms) allow a much larger 40 percent of the river cross-section (see subsection iii below). In addition, the river flow-to-effluent flow ratios when discharging are often significantly greater than the 10:1 ratio required for Discharge Point Nos. 001 and 003 and the 50:1 ratio required for Discharge Point No. 002 by Discharge Prohibition III.B. Higher discharge ratios increase the dilution that occurs within the same size mixing zone. The mixing zone study states the median river flow-to-effluent flow ratios when discharging (data collected from November 2000 to May 2006) are 75:1 for Discharge Point No. 001 and 536:1 for Discharge Point No. 002. (Discharge from Discharge Point No. 003 is permitted under the same conditions as at Discharge Point No. 001.) Thus the mixing zones would typically impact a significantly smaller fraction of the river cross-section under actual discharge conditions. Furthermore, the discharge is seasonally restricted and, even during the discharge season, intermittent.
- ii. No acute toxicity to aquatic life passing through the mixing zones.** The mixing zones will not cause acute toxicity to passing aquatic life because the maximum estimated travel time for an organism to float through the mixing zone is less than six minutes, much shorter than the one-hour time frame acute toxicity water quality objectives are based on. Therefore, aquatic organisms are unlikely to remain in the mixing zone long enough for acutely toxicity to occur. In addition, this Order contains acute toxicity effluent limits and requires acute toxicity testing to demonstrate compliance. These limits do not account for any dilution; therefore, compliance with these limits protects areas within the mixing zones from acute aquatic toxicity. Bioassay monitoring during the past permit cycle showed high survival rates, indicating that organisms passing through the mixing zones are unlikely to experience acute toxicity.
- iii. No restriction on the passage of aquatic life.** The mixing zones will not restrict the passage of aquatic life because all mixing zones for discharges from Discharge Point Nos. 001 and 002 allow at least two-thirds of the river cross-section along the south bank of the river, opposite from the outfalls, for passage; all mixing zones for discharges from Discharge Point No. 003 except those for chlorodibromomethane and dichlorobromomethane allow at least 40 percent of the river cross-section for passage. The limits for chlorodibromomethane and dichlorobromomethane are based on human health effects from consumption of organisms and water, not chronic or acute

toxic effects on aquatic life; thus, the mixing zones for these pollutants do not restrict the passage of aquatic life. Moreover, the mixing zones are small compared to the size of the river as discussed above.

- iv. No effect on biologically sensitive or critical habitats, including, but not limited to, habitats of species under federal or State endangered species laws.** The Napa River has three potential aquatic species of concern in the area. Steelhead (*Oncorhynchus mykiss irideus*) is a federally-listed “threatened” species known to spawn in the Napa River in January and February. The western pond turtle (*Actinemys marmorata*) is a State-listed species of special concern. The California freshwater shrimp (*Syncaris pacifica*) is a State and federally-listed endangered species. Steelhead may take in pollutants through their gills as they pass through the mixing zones, but because the mixing zones occupy at most 60 percent of the river cross-section and extend at most 530 feet downstream, steelhead are unlikely to reside within the mixing zones for any significant duration that could adversely affect them. Since turtles do not have gills, they are less likely to be adversely affected by contact with diluted effluent than steelhead. Based on their size, freshwater shrimp may be more susceptible to adverse effects; however, they would drift through the mixing zones in less than six minutes, much less than the one-hour time frame for acute water quality objectives or four-day time frame for chronic water quality objectives.
- v. No undesirable or nuisance aquatic life.** The mixing zones will not produce undesirable or nuisance aquatic life. Most of the pollutants for which mixing zones are granted are not biostimulants or plant nutrients so they will not cause growth of aquatic nuisance species. Ammonia contains nitrogen, a plant nutrient; however, ongoing river monitoring does not indicate enriched conditions in the vicinity of the outfalls. Moreover, this Order imposes receiving water limitations that prohibit bottom deposits or aquatic growths to the extent that such deposits or growths cause nuisance or adversely affect beneficial uses.
- vi. No floating debris, oil, or scum.** The mixing zones will not result in floating debris, oil, or scum because the effluent receives secondary or tertiary treatment that eliminates oils, grease, debris, and scum. In addition, this Order imposes receiving water limitations that prohibit floating debris, oil, or scum at any place and at any time.
- vii. No objectionable color, odor, taste, or turbidity.** The mixing zones will not produce objectionable color, odor, taste, or turbidity because the effluent receives secondary or tertiary treatment and is disinfected prior to discharge. Secondary treatment generally addresses objectionable odor, taste, and turbidity through the biological degradation of organic compounds and clarification. In addition, this Order prohibits alteration of color or turbidity beyond natural background levels.
- viii. No objectionable bottom deposits.** The mixing zones will not cause objectionable bottom deposits because the effluent receives secondary or tertiary treatment and is essentially free of settleable solids. In addition, this Order prohibits bottom deposits

or aquatic growths to the extent that such deposits or growths cause nuisance or adversely affect beneficial uses.

- ix. No nuisance.** The mixing zones will not cause a nuisance because the effluent receives secondary or tertiary treatment prior to discharge. This Order also prohibits discharges from causing a nuisance, which California Water Code Section 13050(m) defines to mean anything that meets all three of the following criteria:
- is injurious to health, or is indecent or offensive to the senses, or an obstruction to the free use of property, so as to interfere with the comfortable enjoyment of life or property;
 - affects at the same time an entire community or neighborhood, or any considerable number of persons, although the extent of the annoyance or damage inflicted upon individuals may be unequal; and
 - occurs during, or as a result of, the treatment or disposal of wastes.
- x. Do not dominate the receiving water body or overlap a mixing zone from a different outfall.** The mixing zones will not overlap any mixing zone from a different outfall because the Regional Water Board has not established any other mixing zone nearby. The nearest other mixing zones begin approximately 10 miles downstream at the discharge point of the City of St. Helena Wastewater Treatment and Reclamation Plant. When discharging from more than one discharge point, the mixing zones at Discharge Point Nos. 001, 002, and 003 will not overlap because the distances between discharge points exceed the maximum length of the mixing zones. (The distance from Discharge Point No. 001 to Discharge Point No. 002 is about 400 feet; however, discharge from both points at once is permitted only at river flow-to-effluent flow ratios of 50:1 or greater. The distance from Discharge Point No. 001 to Discharge Point No. 003 is about 1,200 feet, and from Discharge Point No. 002 to Discharge Point No. 003 is about 800 feet.)
- xi. Not located at or near any drinking water intake.** The mixing zones will not be located at or near any drinking water intakes because there are no drinking water intakes in the upper Napa River within 530 feet of Discharge Point No. 001, 43 feet of Discharge Point No. 002, or 500 feet of Discharge Point No. 003.

In accordance with SIP section 1.4.2.2.B, the mixing zones protect beneficial uses and comply with regulatory requirements. None of the pollutants for which mixing zones are granted are carcinogenic, bioaccumulative, or persistent in the environment, with the exception of chlorodibromomethane and dichlorobromomethane, which are potential carcinogens. However, they do not persist in the environment and water within these mixing zones will not be ingested directly without thorough mixing. The Napa River flows freely at the point of discharge, flushing and diluting pollutants downstream.

SIP section 1.4.2.2 requires mixing zones to be as small as practicable. This Order grants mixing zones corresponding to a 10:1 dilution credit ($D=9$) for chlorodibromomethane, dichlorobromomethane, and all pollutants with municipal and agricultural supply objectives that are not also priority pollutants (see the reasonable potential analysis

described in Fact Sheet section IV.C.3.c). The chlorodibromomethane and dichlorobromomethane mixing zones are as small as practical; corresponding dilution credits are the same as those in the previous order and the Discharger has demonstrated difficulty complying with the resulting WQBELs. The mixing zones for the municipal and agricultural supply pollutants are as small as practical because smaller mixing zones would not be meaningful since complete mixing is expected before municipal or agricultural supply use.

This Order grants smaller mixing zones for antimony, boron, cyanide, copper, and ammonia. In these instances, to ensure that the mixing zones are as small as possible, the WQBELs were calculated using the smallest possible dilution credits corresponding to current performance. The dilution credits are the minimum necessary for the Discharger to consistently comply with the WQBELs (the 95th percentiles of representative effluent data are less than the average monthly WQBELs, and the 99th percentiles are less than the maximum daily WQBELs). The corresponding mixing zones are much smaller than the 530-foot mixing zone associated with 10:1 dilution. This Order allows dilution credits of D=1 for antimony, D=3 for cyanide and copper, D=4 for boron (significantly less than the dilution credit of D = 9 used in the reasonable potential analysis to ensure that the WQBELs are based on a mixing zone that is as small as practicable), and D=5 for ammonia, corresponding to estimated maximum mixing zone sizes (by area) of approximately 3.4 feet by 2.4 feet, 26 feet by 5.3 feet, 58 feet by 9.6 feet, and 120 feet by 12 feet. Regional Water Board staff estimated these mixing zone sizes based on CORMIX output the Discharger provided.

For reasonable potential analysis for chronic toxicity, Basin Plan 4.5.5.3.2 states, “[allow] credit for dilution comparable to those allowed for numeric chemical specific objectives, effluent variability, and intent to protect against consistent chronic toxicity and severe episodic toxic events.” This Order uses a dilution credit of 4:1 (D = 3), which is more than that granted for antimony and equal to that granted for cyanide and copper, which are all toxic pollutants with water quality objectives intended to protect aquatic life. The corresponding mixing zone size is 26 feet by 5.3 feet. (See this reasonable potential analysis described in Fact Sheet section IV.c.3.g.)

- b. WQBEL Calculations.** For those pollutants with reasonable potential, AMELs and MDELs were calculated as shown in the table below:

Table F-9. WQBEL Calculations

PRIORITY POLLUTANTS	Antimony	Boron	Cyanide	Copper	Chlorodi-bromo-methane	Dichloro-bromo-methane	Total Ammonia (acute)	Total Ammonia (chronic)
Units	µg/L	µg/L	µg/L	µg/L	µg/L	µg/L	mg/L N	mg/L N
Basis and Criteria type	Basin Plan	Basin Plan	NTR	Basin Plan	CTR Human Health	CTR Human Health	Basin Plan Aquatic Life	Basin Plan Aquatic Life
Criteria -Acute	-----	-----	22	8.5	-----	-----	14	-----
Criteria -Chronic	-----	2,000	5.2	5.9	-----	-----	-----	5.0
Criteria -Human Health	-----	-----	-----	-----	0.41	0.56	-----	-----
Water Effects	1	1	1	1	1	1	1	1

PRIORITY POLLUTANTS	Antimony	Boron	Cyanide	Copper	Chlorodi-bromo-methane	Dichloro-bromo-methane	Total Ammonia (acute)	Total Ammonia (chronic)
Units	µg/L	µg/L	µg/L	µg/L	µg/L	µg/L	mg/L N	mg/L N
Ratio (WER)								
Lowest WQO	6.0	2,000	5.2	5.9	0.40	0.56	14	5.0
Dilution Factor (D) (if applicable)	1	4	3	3	9	9	2	5
No. of samples per month	4	4	4	4	4	4	4	30 ^[1]
Aquatic life criteria analysis required? (Y/N)	N	Y	Y	Y	N	N	Y	Y
HH criteria analysis required? (Y/N)	Y	N	Y	Y	Y	Y	N	N
Applicable Acute WQO	-----	-----	22	8.5	-----	-----	14	-----
Applicable Chronic WQO	-----	2,000	5.2	5.9	-----	-----	-----	5.0
HH criteria	14	-----	700	1,300	0.41	0.56	-----	-----
Background (Maximum Conc for Aquatic Life calc)	-----	1,500	<0.60	3.1	-----	-----	-----	0.0
Background (Average Conc for Human Health calc)	1.8	-----	<0.60	3.1	<0.080	<0.080	-----	-----
Is the pollutant on the 303d list and/or bioaccumulative (Y/N)?	N	N	N	N	N	N	N	N
ECA acute	-----	-----	86	25	-----	-----	41	-----
ECA chronic	-----	4,000	19	14	-----	-----	-----	30
ECA HH	26	-----	2,800	5,200	3.4	4.9	-----	-----
No. of data points <10 or at least 80% of data reported non detect? (Y/N)	N	Y	N	N	N	N	N	N
Avg of effluent data points	25	2,683	2.1	5.2	3.0	7.5	2.7	2.7
Std Dev of effluent data points	7.5	402	1.5	2.3	2.8	7.3	4.2	4.2
CV calculated	0.30	N/A	0.75	0.43	0.94	0.96	1.6	1.6
CV (Selected) - Final	0.30	0.60	0.75	0.43	0.94	0.96	1.6	1.6

PRIORITY POLLUTANTS	Antimony	Boron	Cyanide	Copper	Chlorodi-bromo-methane	Dichloro-bromo-methane	Total Ammonia (acute)	Total Ammonia (chronic)
Units	µg/L	µg/L	µg/L	µg/L	µg/L	µg/L	mg/L N	mg/L N
ECA acute mult99	-----	0.32	0.26	0.42	-----	-----	0.14	0.14
ECA chronic mult99	-----	0.53	0.46	0.62	-----	-----	0.25	0.25
LTA acute	-----	-----	23	10	-----	-----	5.7	-----
LTA chronic	-----	2,100	8.7	9.0	-----	-----		7.6
minimum of LTAs	-----	2,100	8.7	9.0	-----	-----	5.7	7.6
AMEL mult95	1.3	1.6	1.7	1.4	1.9	1.9	2.5	1.5
MDEL mult99	1.9	3.1	3.8	2.4	4.6	4.7	7.2	7.2
AMEL (aq life)	-----	3,300	15	13	-----	-----	14	12
MDEL(aq life)	-----	6,600	33	22	-----	-----	41	55
MDEL/AMEL Multiplier	1.5	2.0	2.2	1.7	2.5	2.5	2.9	4.7
AMEL (HH)	26	-----	2,800	5,200	3.4	4.9	-----	-----
MDEL (HH)	39	-----	6,200	9,000	8.3	12	-----	-----
minimum of AMEL for Aq. life vs HH	26	3,300	15	13	3.4	4.9	14	12
minimum of MDEL for Aq. Life vs HH	39	6,600	33	22	8.3	12	41	55
Previous order limit (average monthly)	25	-----	7.3	11	3.4	4.9	-----	-----
Previous order limit (maximum daily)	36	-----	18	20	6.4	9.0	-----	-----
Final limit - AMEL	25	3,300	7.3	11	3.4	4.9	[2]	12
Final limit - MDEL	36	6,600	18	20	6.4	9.0		55

Footnotes:

[1] Statistical adjustments were made to the total ammonia WQBEL calculations. The SIP assumes a 4-day average concentration and a monthly sampling frequency of 4 days per month to calculate effluent limitations based on chronic criteria, but the Basin Plan chronic water quality objective for un-ionized ammonia is based on an annual median instead of the typical 4-day average. Therefore, a 365-day average and a monitoring frequency of 30 days per month (the maximum daily sampling frequency in a month since the averaging period for the chronic criteria is longer than 30 days) were used. These statistical adjustments are supported by U.S. EPA's *Water Quality Criteria; Notice of Availability; 1999 Update of Ambient Water Quality Criteria for Ammonia* (64 Fed. Reg. 71974-71980, December 22, 1999).

[2] The final ammonia WQBELs are based on the chronic water quality objective because they result in lower long-term average effluent concentrations.

- c. **Whole Effluent Acute Toxicity.** This Order includes whole effluent acute toxicity effluent limitations based on Basin Plan Table 4-3. Compliance is to be evaluated based on 96-hour continuous flow-through bioassays. Bioassays are to be performed as specified in MRP section V.A. According to the Order, acute toxicity caused only by ammonia present in the effluent at levels below the ammonia effluent limits does not constitute an acute toxicity limit violation. This is because ammonia will be diluted in the receiving water and will degrade to a non-toxic state fairly rapidly. The ammonia effluent limits are calculated to protect beneficial uses.

D. Discharge Requirement Considerations

1. **Anti-backsliding.** This Order complies with the anti-backsliding provisions of CWA sections 402(o) and 303(d)(4), and 40 C.F.R. section 122.44(l), which generally require effluent limitations in a reissued permit to be as stringent as those in the previous order. The requirements of this Order are at least as stringent as those in the previous order.

This Order does not retain WQBELs for dioxin-TEQ from the previous order because data do not indicate reasonable potential to exceed water quality objectives. This is consistent with State Water Board Order No. WQ 2001-16.

2. **Antidegradation.** This Order complies with the antidegradation provisions of 40 C.F.R. section 131.12 and State Water Board Resolution No. 68-16. It continues the status quo with respect to the level of discharge authorized in the previous order, which is the baseline by which to measure whether degradation will occur. This Order does not allow for an increase in flow, a reduced level of treatment, or less stringent effluent limitations relative to those in the previous order.
 - a. **New Discharge Point.** This Order authorizes a new discharge point, Discharge Point No. 003. Discharge Point No. 003 may facilitate discharging at higher rates over short periods. However, this Order does not authorize an increased discharge volume compared to the previous order. This Order contains essentially the same prohibition against average dry-weather inflows greater than the plant design treatment capacity (Prohibition III.D). This Order also retains the previous order's prohibitions against discharge without at least a 10:1 river flow-to-effluent flow ratio (Prohibition III.B) and discharge during the dry season (Prohibition III.F). Finally, this Order retains within the Facility Description (Fact Sheet section II) the plant's average dry-weather treatment capacity of 0.84 MGD and peak wet-weather treatment capacity of 4.0 MGD.
 - b. **Removal of Temperature Prohibition.** This Order removes a prohibition from the previous order against discharge of elevated temperature into the Napa River; however, this removal will not degrade water quality because monitoring during the past permit cycle showed no temperature difference between the effluent and receiving water.
3. **Stringency of Requirements for Individual Pollutants.** This Order contains both technology-based and water quality-based effluent limitations for individual pollutants. This Order's technology-based requirements implement minimum, applicable federal technology-based requirements. In addition, this Order contains more stringent effluent limitations as

necessary to meet water quality standards. Collectively, this Order's restrictions on individual pollutants are no more stringent than required to implement CWA requirements.

This Order's WQBELs have been derived to implement water quality objectives that protect beneficial uses. The beneficial uses and water quality objectives have been approved pursuant to federal law and are the applicable federal water quality standards. To the extent that WQBELs were derived from the CTR, the CTR is the applicable standard pursuant to 40 C.F.R. section 131.38. The procedures for calculating these WQBELs are based on the CTR, as implemented in accordance with the SIP, which U.S. EPA approved on May 18, 2000. U.S. EPA approved most Basin Plan beneficial uses and water quality objectives prior to May 30, 2000. Beneficial uses and water quality objectives submitted to U.S. EPA prior to May 30, 2000, but not approved by U.S. EPA before that date, are nonetheless "applicable water quality standards for purposes of the CWA" pursuant to 40 C.F.R. section 131.21(c)(1). U.S. EPA approved the remaining beneficial uses and water quality objectives so they are applicable water quality standards pursuant to 40 C.F.R. section 131.21(c)(2).

V. RATIONALE FOR RECEIVING WATER LIMITATIONS

The receiving water limitations in sections V.A and V.B of this Order are based on Basin Plan narrative and numeric water quality objectives. The receiving water limitation in section V.C of this Order requires compliance with federal and State water quality standards in accordance with the CWA and regulations adopted thereunder.

VI. RATIONALE FOR PROVISIONS

A. Standard Provisions

Attachment D contains standard provisions that apply to all NPDES permits in accordance with 40 C.F.R. section 122.41 and additional conditions applicable to specific categories of permits in accordance with 40 C.F.R. section 122.42. The Discharger must comply with these provisions. The conditions set forth in 40 C.F.R. sections 122.41(a)(1) and (b) through (n) apply to all state-issued NPDES permits and must be incorporated into the permits either expressly or by reference.

In accordance with 40 C.F.R. section 123.25(a)(12), states may omit or modify conditions to impose more stringent requirements. Attachment G contains standard provisions that supplement the federal standard provisions in Attachment D. This Order omits federal conditions that address enforcement authority specified in 40 C.F.R. sections 122.41(j)(5) and (k)(2) because the State's enforcement authority under the Water Code is more stringent. In lieu of these conditions, this Order incorporates Water Code section 13387(e) by reference.

B. Monitoring and Reporting

Pursuant to 40 C.F.R. section 122.48, NPDES permits must specify requirements for recording and reporting monitoring results. Water Code sections 13267 and 13383, and 40 C.F.R. sections 122.41(h) and (j), authorize the Regional Water Board to require technical and monitoring reports. This Order establishes monitoring and reporting requirements, contained in the Monitoring and Reporting Program (Attachment E), that implement federal and State requirements. For more background regarding these requirements, see Fact Sheet section VII.

C. Special Provisions

1. Reopener Provisions

These provisions are based on 40 C.F.R. sections 122.62 and 122.63 and allow modification of this Order and its effluent limitations as necessary in response to updated water quality objectives, regulations, or other new and relevant information that may become available in the future, and other circumstances as allowed by law.

2. Effluent Characterization Study and Report

This Order does not include effluent limitations for priority pollutants that do not demonstrate reasonable potential, but this provision requires the Discharger to continue monitoring for these pollutants as described in the MRP and Attachment G. Monitoring data are necessary to verify that the “no” and “unknown” reasonable potential analysis conclusions of this Order remain valid. This requirement is authorized pursuant to CWC section 13267, and is necessary to inform the next permit reissuance and to ensure that the Discharger takes timely steps in response to any unanticipated change in effluent quality during the term of this Order.

3. Receiving Water Characterization Study and Report

This Order does not include effluent limitations for pollutants that do not demonstrate reasonable potential, but this provision requires the Discharger to continue monitoring for these pollutants as described in the MRP and Attachment G. Monitoring data are necessary to verify that the “no” and “unknown” reasonable potential analysis conclusions of this Order remain valid. This requirement is authorized pursuant to CWC section 13267, and is necessary to inform the next permit reissuance. This Order allows the Discharger to complete the study on its own or in collaboration with other Napa River dischargers.

4. Pollutant Minimization Program

This provision is based on Basin Plan section 4.13.2 and SIP section 2.4.5.

5. Special Provisions for Municipal Facilities

- a. Sludge and Biosolids Management.** This provision is based on Basin Plan section 4.17 and 40 C.F.R. parts 257 and 503. “Sludge” refers to the solid, semisolid, and liquid residue removed during primary, secondary, and advanced wastewater treatment processes. “Biosolids” refers to sludge that has been treated and may be beneficially reused.
- b. Collection System Management.** The Discharger’s collection system is part of the Facility regulated through this Order. This provision explains this Order’s requirements as they relate to the Discharger’s collection system and promotes consistency with the State Water Board’s Statewide General Waste Discharge Requirements for Sanitary Sewer Systems (General Collection System WDRs), Order 2006-0003-DWQ, as amended by WQ 2013-0058-EXEC. The General Collection System WDRs contain requirements for collection system operation and maintenance, and for reporting and

mitigating sanitary sewer overflows. They also require agencies to develop sanitary sewer management plans and report all sanitary sewer overflows. The Discharger must comply with both the General Collection System WDRs and this Order.

6. Wastewater Pond Operation Requirements

This provision is consistent with proper operation of wastewater treatment facilities to ensure that oxygen levels in the effluent stored in the wastewater ponds do not drop to such a level where the discharge would cause an exceedance of the receiving water limit for dissolved oxygen. This would also ensure that storage does not cause odors. The minimum dissolved oxygen concentration requirement would prevent pond contents from becoming anaerobic. The maximum dissolved sulfide concentration requirement is intended to prevent formation of hydrogen sulfide, which can be noxious.

7. Anaerobically Digestible Material

Standard Operating Procedures are required for dischargers that accept hauled waste food, fats, oil, and grease for injection into anaerobic digesters. The development and implementation of Standard Operating Procedures for management of these materials is intended to allow the California Department of Resources Recycling and Recovery to exempt operations from separate and redundant permitting programs. If the Discharger does not accept fats, oil, and grease for resource recovery purposes, it is not required to develop and implement Standard Operating Procedures.

Some publically owned treatment works choose to accept organic material, such as waste food, fats, oils, and grease, into their anaerobic digesters to increase production of methane and other biogases for energy production and to prevent such materials from being discharged into the collection system and potentially causing sanitary sewer overflows. The California Department of Resources Recycling and Recovery has proposed to exclude publically owned treatment works from Process Facility/Transfer Station permit requirements when the same activities are regulated under waste discharge requirements or NPDES permits. The proposed exclusion is restricted to anaerobically digestible materials that have been prescreened, slurried, processed, and conveyed in a closed system for co-digestion with regular sewage sludge. The exclusion assumes that the facility has developed Standard Operating Procedures for proper handling, processing, tracking, and management.

8. Conditions for Discharge Point No. 003

This provision is based on 40 C.F.R. section 122.41(*l*). It specifies conditions that must be met before the Discharger begins discharging from the new outfall. It is necessary so the Regional Water Board knows when discharges commence and therefore when this Order's provisions apply to the new outfall. Additionally, it is necessary to ensure that the new outfall is constructed appropriately and can operate in compliance with this Order. Discharges from Discharge Point No. 003 do not flow through the Riverside Ponds, which assist in removing chlorodibromomethane and dichlorobromomethane. Thus discharges from Discharge Point No. 003 will require additional measures to ensure sufficient removal of chlorodibromomethane and dichlorobromomethane to comply with effluent limits.

9. Amendment of NPDES Permit No. CA0038849

This provision is necessary to ensure that the new outfall is subject to NPDES Permit No. CA0038849 (mercury and PCBs watershed permit) requirements on mercury and PCBs.

VII. RATIONALE FOR MONITORING AND REPORTING PROGRAM (MRP)

Attachment E contains the MRP for this Order. It specifies sampling stations, pollutants to be monitored (including all parameters for which effluent limitations are specified), monitoring frequencies, and reporting requirements. The following provides the rationale for the MRP requirements.

A. MRP Requirements Rationale

1. **Influent Monitoring.** Influent flow monitoring is necessary to understand Facility operations and to evaluate compliance with Discharge Prohibition III.D, which prohibits dry weather influent flow greater than 0.84 MGD. Influent BOD₅ and TSS monitoring is necessary to evaluate compliance with this Order's 85 percent removal requirements.
2. **Effluent Monitoring.** Effluent flow monitoring is necessary to distinguish flows discharged to the Napa River versus flows that go to the irrigation fields or are reused. Monitoring for the other parameters is necessary to evaluate compliance with this Order's effluent limitations and to conduct future reasonable potential analyses.
3. **Whole Effluent Toxicity Testing.** Acute whole effluent toxicity tests are necessary to evaluate compliance with the acute toxicity effluent limitations.
4. **Recycled Water Monitoring.** The Discharger is required to report the amount of recycled water it supplies to its users so the Regional Water Board and State Water Board can track recycled water use locally and statewide.
5. **Receiving Water Monitoring.** Napa River flow monitoring is needed to determine the river flow-to-effluent flow ratio and evaluate compliance with Discharge Prohibition III.B. Monitoring for hardness is necessary to determine applicable water quality objectives. Monitoring for pH and temperature is necessary to provide data to translate the Basin Plan's un-ionized ammonia water quality objectives into total ammonia criteria. Monitoring for total ammonia may be useful to complete future reasonable potential analyses. Monitoring for antimony, boron, and copper may be useful to confirm that the effluent limitations for these pollutants are maintaining ambient concentrations below water quality objectives as intended.
6. **Other Monitoring Requirements.**
 - a. Biosolids monitoring is required pursuant to 40 C.F.R. section Part 258 (for landfill disposal) or 40 C.F.R. section 503 (for land application).
 - b. Wastewater pond monitoring requirements are needed to ensure that effluent stored in the wastewater ponds meets Provision VI.C.6's limits on dissolved oxygen and dissolved sulfide.

- c. Precipitation monitoring is needed to ensure that sufficient wastewater pond freeboard exists to prevent overflow, in accordance with Basin Plan Section 4.9.3.

B. Monitoring Requirements Summary. The table below summarizes routine monitoring requirements. This table is for informational purposes only. The actual requirements are specified in the MRP and elsewhere in this Order.

Table F-10. Monitoring Requirements Summary

Parameter	Influent INF-001	Effluent EFF-001, EFF-002, and EFF-003	Receiving Water RSW-001 through RSW-008 ^[1]	Ponds PON-001 through PON-004	Re-use REC-001	Biosolids BIO-001
Flow	1/Day	Continuous/D	1/Day	----	Continuous/D	----
BOD ₅	1/Week	1/Week	----	----	----	----
TSS	1/Week	1/Week	----	----	----	----
Oil and Grease	----	1/Month	----	----	----	----
pH	----	Continuous/D	1/Quarter	----	----	----
Temperature	----	1/Day	1/Quarter	----	----	----
Turbidity	----	1/Day	----	----	----	----
Total Coliform Bacteria ^[4]	----	3/Week	----	----	----	----
Dissolved Oxygen	----	----	1/Quarter	2/Year	----	----
Dissolved Sulfide	----	----	----	2/Year	----	----
Acute Toxicity	----	1/Month	----	----	----	----
Chlorine Residual	----	1/2H	----	----	----	----
Antimony, Total Recoverable	----	1/Month	1/Quarter	----	----	----
Boron, Total Recoverable	----	1/Month	1/Quarter	----	----	----
Copper, Total Recoverable	----	1/Month	1/Quarter	----	----	----
Cyanide, Total Recoverable	----	1/Month	----	----	----	----
Chlorodibromomethane	----	1/Month	----	----	----	----
Dichlorobromomethane	----	1/Month	----	----	----	----
Ammonia, Total	----	1/Month	1/Quarter	----	----	----
Hardness	----	----	1/Quarter	----	----	----
Salinity or Total Dissolved Solids	----	----	1/Quarter	----	----	----
Standard Observations	----	1/Week	1/Week	1/Month	----	----
Other Pollutants	----	Once	Once ^[3]	----	----	----
River Flow-to-Effluent Flow Ratio	----	1/Day	----	----	----	----
Paint Filter Test	----	----	----	----	----	1/Year

Sampling Frequencies:

- Continuous/D = measured continuously, and recorded and reported daily
- 1/2H = once per 2 hours
- 1/Day = once per day
- 1/Week = once per week
- 3/Week = three times per week
- 1/Month = once per month
- 1/Quarter = once per quarter
- 2/Year = twice per year
- Once = once per permit term (prior to application for permit reissuance).

Footnotes:

^[1] Until Discharge Point No. 003 is constructed and authorized pursuant to Provision VI.C.8 of the Order, only flow monitoring is required at Monitoring Location RSW-007; monitoring for all other parameters is required at all other monitoring locations (however, monitoring at Monitoring Location RSW-005 is only required when discharging at Discharge Point No. 002). When Discharge Point No. 003 is constructed and authorized pursuant to Provision VI.C.8 of the Order, monitoring is no longer required at Monitoring Location RSW-006; monitoring for

all other parameters is required at all other monitoring locations, including Monitoring Location RSW-007 (monitoring at Monitoring Location RSW-005 is only required when discharging at Discharge Point No. 002).

^[2] Provision VI.C.3 of the Order provides for alternative monitoring at Monitoring Location RSW-900.

VIII. PUBLIC PARTICIPATION

The Regional Water Board considered the issuance of WDRs that will serve as an NPDES permit for the Facility. As a step in the WDR adoption process, Regional Water Board staff developed tentative WDRs and encouraged public participation in the WDR adoption process.

A. Notification of Interested Parties. The Regional Water Board notified the Discharger and interested agencies and persons of its intent to prescribe WDRs for the discharge and provided an opportunity to submit written comments and recommendations. Notification was provided through *The Napa Valley Register* in the City of Napa, California. The public had access to the agenda and any changes in dates and locations through the Regional Water Board's website at <http://www.waterboards.ca.gov/sanfranciscobay>.

B. Written Comments. Interested persons were invited to submit written comments concerning the tentative WDRs as explained through the notification process. Comments were to be submitted either in person or by mail to the Executive Office at the Regional Water Board at 1515 Clay Street, Suite 1400, Oakland, California 94612, to the attention of Vince Christian.

For full staff response and Regional Water Board consideration, the written comments were due at the Regional Water Board office by 5:00p.m. on January 19, 2016.

C. Public Hearing. The Regional Water Board held a public hearing on the tentative WDRs during its regular meeting at the following date and time, and at the following location:

Date: February 10, 2016
Time: 9:00 am
Location: Elihu Harris State Office Building
1515 Clay Street, 1st Floor Auditorium
Oakland, CA 94612

Contact: John H. Madigan, P.E., (510) 622-2405, JMadigan@waterboards.ca.gov.

Interested persons were invited to attend. At the public hearing, the Regional Water Board heard testimony pertinent to the discharge, WDRs, and permit. For accuracy of the record, important testimony was requested to be in writing.

Dates and venues change. The Regional Water Board web address is <http://www.waterboards.ca.gov/sanfranciscobay>, where one could access the current agenda for changes in dates and locations.

D. Reconsideration of Waste Discharge Requirements. Any aggrieved person may petition the State Water Board to review the Regional Water Board decision regarding the final WDRs. The State Water Board must receive the petition at the following address within 30 calendar days of the Regional Water Board action:

State Water Resources Control Board
Office of Chief Counsel

P.O. Box 100, 1001 I Street
Sacramento, CA 95812-0100

For instructions on how to file a petition for review, see
http://www.waterboards.ca.gov/public_notices/petitions/water_quality/wqpetition_instr.shtml.

- E. Information and Copying.** The Report of Waste Discharge, related supporting documents, and comments received are on file and may be inspected at the address above at any time between 9:00 a.m. and 5:00 p.m., Monday through Friday. Copying of documents may be arranged by calling (510) 622-2300.
- F. Register of Interested Persons.** Any person interested in being placed on the mailing list for information regarding the WDRs and NPDES permit should contact the Regional Water Board, reference the Facility, and provide a name, address, and phone number.
- G. Additional Information.** Requests for additional information or questions regarding this Order should be directed to John H. Madigan at (510) 622-2405 or JMadigan@waterboards.ca.gov.

APPENDIX F-1 RIVER FLOW-TO-EFFLUENT FLOW RATIO CALCULATIONS

The flow balance for the Napa River from a point just upstream of the City of Calistoga's outfalls to a point just downstream of the Town of Yountville's outfall can be expressed as in Equation 1.

$$Q_{\text{RivUpstrm}} + Q_c + Q_{\text{sh}} + Q_y + Q_{\text{urban}} + Q_{\text{trib}} = Q_{\text{RivDnstrm}}$$

Where:

- $Q_{\text{RivUpstrm}}$ = Upstream River Flow
- Q_c = Calistoga Effluent Flow
- Q_{sh} = Saint Helena Effluent Flow
- Q_y = Yountville Effluent Flow
- Q_{urban} = Urban Runoff Flow
- Q_{trib} = Tributary Flow
- $Q_{\text{RivDnstrm}}$ = Downstream River Flow

Conservatively assuming that Q_{trib} is negligible during the early part of the discharge season, this equation yields:

$$\textbf{Equation 1: } Q_{\text{RivUpstrm}} + Q_c + Q_{\text{sh}} + Q_y + Q_{\text{urban}} = Q_{\text{RivDnstrm}}$$

Conservatively using the wet weather influent data¹ to estimate the flows of each wastewater treatment facility.

$$\begin{aligned} Q_c &= 0.89 \text{ Mgal/day} \\ Q_{\text{sh}} &= 1.0 \text{ Mgal/day} = 1.12 * Q_c \\ Q_y &= 0.80 \text{ Mgal/day} = 0.90 * Q_c \end{aligned}$$

Thus:

$$\textbf{Equation 2: } Q_c + Q_{\text{sh}} + Q_y = 3.02 * Q_c = 2.69 \text{ Mgal/day} = 982 \text{ Mgal/year}$$

Q_{urban} can be estimated through this equation:²

$$Q_{\text{urban}} = C_{\text{mun}} * I * A_{\text{mun}} + C_{\text{ind}} * I * A_{\text{ind}}$$

Where:

- I = rainfall = 30 inches / year
- C_{mun} = municipal runoff fraction = 0.2
- C_{ind} = industrial runoff fraction = 1.0
- A_{mun} = municipal area = 25,667 acres

¹ Average flow data are from Calistoga, St. Helena, and Yountville self-monitoring reports for December 2014, a very wet month.

² This equation, the runoff fractions, and land use areas are from Table 7b of the staff report for the Napa River Sediment Total Maximum Daily Load (January 16, 2007).

A_{ind} = industrial area = 1,447 acres

$$Q_{urban} = [0.2(30in/year)(25667acres) + 1.0(30in/year)(1447acres)] \times \left[\frac{1.008ft^3/sec}{acre-in/hr} \right] \times \left[\frac{3600sec}{hr} \right] \times \left[\frac{7.4805gal}{ft^3} \right]$$

$$Q_{urban} = 5,359 \text{ Mgal/year}$$

Therefore, Q_{urban} is about five and a half times the combined flow of the treatment plants.

$$\frac{Q_{urban}}{Q_c + Q_{sh} + Q_y} = \frac{5,359 \text{ Mgal/year}}{982 \text{ Mgal/year}} = 5.5$$

$$Q_{Urban} = 5.5 * (Q_c + Q_{sh} + Q_y)$$

Substituting this ratio into Equation 1:

$$Q_{RivUpstrm} + 6.5 * (Q_c + Q_{sh} + Q_y) = Q_{RivDnstrm}$$

Solving for $Q_{RivUpstrm}$:

$$Q_{RivUpstrm} = Q_{RivDnstrm} - 6.5 * (Q_c + Q_{sh} + Q_y) =$$

Using Equation 2 ($[Q_c + Q_{sh} + Q_y] = 3.02 * Q_c$):

Equation 3: $Q_{RivUpstrm} = Q_{RivDnstrm} - 19.6 * Q_c$

Effluent and ambient background data suggest that the Napa River’s assimilative capacity may be most limited with respect to copper. Therefore, the minimum river flow-to-effluent flow ratio is calculated by setting the background, effluent, and runoff copper mass equal to the downstream copper mass based on the downstream flow and copper water quality objective (C_o).

The copper mass balance can be expressed as follows:

Equation 4: $Q_{RivUpstrm} * C_b + Q_c * C_c + Q_{sh} * C_{sh} + Q_y * C_y + Q_{urban} * C_{urban} = Q_{RivDnstrm} * C_o$

Where:

- C_b = Upstream Background River Copper Concentration
- C_c = Calistoga Effluent Copper Concentration
- C_{sh} = Saint Helena Effluent Copper Concentration
- C_y = Yountville Effluent Copper Concentration
- C_{urban} = Urban Runoff Copper Concentration
- C_{trib} = Tributary Copper Concentration
- C_o = Downstream River Copper Water Quality Objective Concentration

Assuming that urban and non-urban runoff copper loads are about eight times those of the wastewater treatment plants yields the following:¹

$$Q_{urban} * C_{urban} = 8 * (Q_c * C_c + Q_{sh} * C_{sh} + Q_y * C_y)$$

Combining the above equation with Equation 4 yields the following:

$$Q_{RivUpstrm} * C_b + 9 * (Q_c * C_c + Q_{sh} * C_{sh} + Q_y * C_y) = Q_{RivDnstrm} * C_o$$

Substituting Equation 3 into Equation 4 and solving for the river flow-to-effluent flow ratio yields the following:

$$\frac{Q_{RivDnstrm}}{Q_c} = \frac{19.6 \times C_b - 10.08 \times C_{sh} - 8.1 \times C_y - 9 \times C_c}{C_b - C_o}$$

Effluent copper concentrations are conservatively based on each wastewater treatment plant's 95th percentile effluent copper concentration from 2010 through 2014. The downstream copper water quality objective (7.9 mg/L) is based on Basin Plan Table 3-4 and the lowest measured downstream hardness of 82 mg/L. The background copper concentration (3.1 mg/L) is based on the highest upstream measurement the Discharger collected from February 2002 through March 2015.

- C_c = 8.9 mg/L
- C_{sh} = 6.8 mg/L
- C_y = 16 mg/L
- C_o = 7.9 mg/L
- C_b = 3.1 mg/L

Substituting these values into the equation above:

$$\frac{Q_{RivDnstrm}}{Q_c} = \frac{19.6 \times 3.1 - 10.08 \times 6.8 - 8.1 \times 16 - 9 \times 8.9}{3.1 - 7.9} = \frac{45}{1}$$

The existing river flow-to-effluent flow ratios of 10:1 for tertiary-treated wastewater and 50:1 for secondary-treated wastewater are retained from the previous order to ensure that the Napa River's water quality will not be degraded as a result of the combined discharges of Calistoga, St. Helena, and Yountville, and that its beneficial uses will be protected. The 50:1 river flow-to-effluent flow ratio is also retained also to encourage maximum wastewater recycling and full use of the plant's tertiary treatment capacity. This ratio is higher than 45:1 to justify, in part, an exception to Basin Plan Discharge Prohibition 1 and to avoid backsliding.

¹ The relative copper loads are from the staff report for the Copper Site Specific Objectives (June 6, 2007).

**CALIFORNIA REGIONAL WATER QUALITY CONTROL BOARD
SAN FRANCISCO BAY REGION**

**ATTACHMENT G
REGIONAL STANDARD PROVISIONS, AND MONITORING
AND REPORTING REQUIREMENTS
(SUPPLEMENT TO ATTACHMENT D)**

For

NPDES WASTEWATER DISCHARGE PERMITS

March 2010

Contents

I. STANDARD PROVISIONS - PERMIT COMPLIANCE.....	G-1
A. Duty to Comply	G-1
B. Need to Halt or Reduce Activity Not a Defense	G-1
C. Duty to Mitigate	G-1
1. Contingency Plan	G-1
2. Spill Prevention Plan.....	G-2
D. Proper Operation & Maintenance.....	G-2
1. Operation and Maintenance (O&M) Manual.....	G-2
2. Wastewater Facilities Status Report	G-2
3. Proper Supervision and Operation of Publicly Owned Treatment Works (POTWs)	G-3
E. Property Rights.....	G-3
F. Inspection and Entry.....	G-3
G. Bypass	G-3
H. Upset.....	G-3
I. Other	G-3
J. Storm water	G-3
1. Storm water Pollution Prevention Plan (SWPP Plan).....	G-3
2. Source Identification.....	G-4
3. Storm water Management Controls	G-5
4. Annual Verification of SWPP Plan.....	G-6
K. Biosolids Management	G-6
II. STANDARD PROVISIONS – PERMIT ACTION.....	G-7
III. STANDARD PROVISIONS – MONITORING	G-7
A. Sampling and Analyses	G-7
1. Use of Certified Laboratories.....	G-7
2. Use of Appropriate Minimum Levels	G-7
3. Frequency of Monitoring	G-7
B. Biosolids Monitoring.....	G-10
1. Biosolids Monitoring Frequency	G-10
2. Biosolids Pollutants to Monitor	G-10
C. Standard Observations.....	G-10
1. Receiving Water Observations	G-10
2. Wastewater Effluent Observations	G-11
3. Beach and Shoreline Observations	G-11
4. Land Retention or Disposal Area Observations.....	G-11
5. Periphery of Waste Treatment and/or Disposal Facilities Observations	G-12
IV. STANDARD PROVISIONS – RECORDS	G-12
A. Records to be Maintained.....	G-12
B. Records of monitoring information	G-12
1. Analytical Information.....	G-12
2. Flow Monitoring Data.....	G-12
3. Wastewater Treatment Process Solids	G-13
4. Disinfection Process.....	G-13
5. Treatment Process Bypasses	G-13
6. Treatment Facility Overflows	G-14
C. Claims of Confidentiality	G-14
V. STANDARD PROVISIONS – REPORTING	G-14
A. Duty to Provide Information	G-14

B. Signatory and Certification RequirementsG-14
C. Monitoring ReportsG-14
 1. Self Monitoring Reports G-14
D. Compliance Schedules G-18
E. Twenty-Four Hour Reporting G-18
 1. Spill of Oil or Other Hazardous Material Reports G-18
 2. Unauthorized Discharges from Municipal Wastewater Treatment Plants G-19
F. Planned Changes G-22
G. Anticipated Noncompliance G-22
H. Other Noncompliance.....G-22
I. Other Information.....G-22
VI. STANDARD PROVISION – ENFORCEMENT G-22
VII. ADDITIONAL PROVISIONS – NOTIFICATION LEVELS G-22
VIII. DEFINITIONS G-22

**CALIFORNIA REGIONAL WATER QUALITY CONTROL BOARD
SAN FRANCISCO BAY REGION**

**REGIONAL STANDARD PROVISIONS, AND MONITORING AND
REPORTING REQUIREMENTS
(SUPPLEMENT TO ATTACHMENT D)**

FOR

NPDES WASTEWATER DISCHARGE PERMITS

APPLICABILITY

This document applies to dischargers covered by a National Pollutant Discharge Elimination System (NPDES) permit. This document does not apply to Municipal Separate Storm Sewer System (MS4) NPDES permits.

The purpose of this document is to supplement the requirements of Attachment D, Standard Provisions. The requirements in this supplemental document are designed to ensure permit compliance through preventative planning, monitoring, recordkeeping, and reporting. In addition, this document requires proper characterization of issues as they arise, and timely and full responses to problems encountered. To provide clarity on which sections of Attachment D this document supplements, this document is arranged in the same format as Attachment D.

I. STANDARD PROVISIONS - PERMIT COMPLIANCE

A. Duty to Comply – Not Supplemented

B. Need to Halt or Reduce Activity Not a Defense – Not Supplemented

C. Duty to Mitigate – This supplements I.C. of Standard Provisions (Attachment D)

- 1. Contingency Plan** - The Discharger shall maintain a Contingency Plan as originally required by Regional Water Board Resolution 74-10 and as prudent in accordance with current municipal facility emergency planning. The Contingency Plan shall describe procedures to ensure that existing facilities remain in, or are rapidly returned to, operation in the event of a process failure or emergency incident, such as employee strike, strike by suppliers of chemicals or maintenance services, power outage, vandalism, earthquake, or fire. The Discharger may combine the Contingency Plan and Spill Prevention Plan into one document. Discharge in violation of the permit where the Discharger has failed to develop and implement a Contingency Plan as described below will be the basis for considering the discharge a willful and negligent violation of the permit pursuant to California Water Code Section 13387. The Contingency Plan shall, at a minimum, contain the provisions of a. through g. below.
 - a. Provision of personnel for continued operation and maintenance of sewerage facilities during employee strikes or strikes against contractors providing services.

- b. Maintenance of adequate chemicals or other supplies and spare parts necessary for continued operations of sewerage facilities.
 - c. Provisions of emergency standby power.
 - d. Protection against vandalism.
 - e. Expeditious action to repair failures of, or damage to, equipment and sewer lines.
 - f. Report of spills and discharges of untreated or inadequately treated wastes, including measures taken to clean up the effects of such discharges.
 - g. Programs for maintenance, replacement, and surveillance of physical condition of equipment, facilities, and sewer lines.
2. **Spill Prevention Plan** - The Discharger shall maintain a Spill Prevention Plan to prevent accidental discharges and minimize the effects of such events. The Spill Prevention Plan shall:
- a. Identify the possible sources of accidental discharge, untreated or partially treated waste bypass, and polluted drainage;
 - b. Evaluate the effectiveness of present facilities and procedures, and state when they became operational; and
 - c. Predict the effectiveness of the proposed facilities and procedures, and provide an implementation schedule containing interim and final dates when they will be constructed, implemented, or operational.

This Regional Water Board, after review of the Contingency and Spill Prevention Plans or their updated revisions, may establish conditions it deems necessary to control accidental discharges and to minimize the effects of such events. Such conditions may be incorporated as part of the permit upon notice to the Discharger.

D. Proper Operation & Maintenance – This supplements I.D of Standard Provisions (Attachment D)

1. **Operation and Maintenance (O&M) Manual** - The Discharger shall maintain an O&M Manual to provide the plant and regulatory personnel with a source of information describing all equipment, recommended operational strategies, process control monitoring, and maintenance activities. To remain a useful and relevant document, the O&M Manual shall be kept updated to reflect significant changes in treatment facility equipment and operational practices. The O&M Manual shall be maintained in usable condition and be available for reference and use by all relevant personnel and Regional Water Board staff.
2. **Wastewater Facilities Status Report** - The Discharger shall regularly review, revise, or update, as necessary, its Wastewater Facilities Status Report. This report shall document how the Discharger operates and maintains its wastewater collection, treatment, and disposal facilities to ensure that all facilities are adequately staffed, supervised, financed, operated, maintained, repaired, and upgraded as necessary to provide adequate and reliable transport, treatment, and disposal of all wastewater from both existing and planned future wastewater sources under the Discharger's service responsibilities.

3. Proper Supervision and Operation of Publicly Owned Treatment Works (POTWs) - POTWs shall be supervised and operated by persons possessing certificates of appropriate grade pursuant to Division 4, Chapter 14, Title 23 of the California Code of Regulations.

E. Property Rights – Not Supplemented

F. Inspection and Entry – Not Supplemented

G. Bypass – Not Supplemented

H. Upset – Not Supplemented

I. Other – This section is an addition to Standard Provisions (Attachment D)

1. Neither the treatment nor the discharge of pollutants shall create pollution, contamination, or nuisance as defined by California Water Code Section 13050.
2. Collection, treatment, storage, and disposal systems shall be operated in a manner that precludes public contact with wastewater, except in cases where excluding the public is infeasible, such as private property. If public contact with wastewater could reasonably occur on public property, warning signs shall be posted.
3. If the Discharger submits a timely and complete Report of Waste Discharge for permit reissuance, this permit continues in force and effect until a new permit is issued or the Regional Water Board rescinds the permit.

J. Storm Water – This section is an addition to Standard Provisions (Attachment D)

These provisions apply to facilities that do not direct all storm water flows from the facility to the wastewater treatment plant headworks.

1. Storm Water Pollution Prevention Plan (SWPP Plan)

The SWPP Plan shall be designed in accordance with good engineering practices and shall address the following objectives:

- a. To identify pollutant sources that may affect the quality of storm water discharges; and
- b. To identify, assign, and implement control measures and management practices to reduce pollutants in storm water discharges.

The SWPP Plan may be combined with the existing Spill Prevention Plan as required in accordance with Section C.2. The SWPP Plan shall be retained on-site and made available upon request of a representative of the Regional Water Board.

2. Source Identification

The SWPP Plan shall provide a description of potential sources that may be expected to add significant quantities of pollutants to storm water discharges, or may result in non-storm water discharges from the facility. The SWPP Plan shall include, at a minimum, the following items:

- a. A topographical map (or other acceptable map if a topographical map is unavailable), extending one-quarter mile beyond the property boundaries of the facility, showing the wastewater treatment facility process areas, surface water bodies (including springs and wells), and discharge point(s) where the facility's storm water discharges to a municipal storm drain system or other points of discharge to waters of the State. The requirements of this paragraph may be included in the site map required under the following paragraph if appropriate.
- b. A site map showing the following:
 - 1) Storm water conveyance, drainage, and discharge structures;
 - 2) An outline of the storm water drainage areas for each storm water discharge point;
 - 3) Paved areas and buildings;
 - 4) Areas of actual or potential pollutant contact with storm water or release to storm water, including but not limited to outdoor storage and process areas; material loading, unloading, and access areas; and waste treatment, storage, and disposal areas;
 - 5) Location of existing storm water structural control measures (i.e., berms, coverings, etc.);
 - 6) Surface water locations, including springs and wetlands; and
 - 7) Vehicle service areas.
- c. A narrative description of the following:
 - 1) Wastewater treatment process activity areas;
 - 2) Materials, equipment, and vehicle management practices employed to minimize contact of significant materials of concern with storm water discharges;
 - 3) Material storage, loading, unloading, and access areas;
 - 4) Existing structural and non-structural control measures (if any) to reduce pollutants in storm water discharges; and
 - 5) Methods of on-site storage and disposal of significant materials.
- d. A list of pollutants that have a reasonable potential to be present in storm water discharges in significant quantities.

3. Storm Water Management Controls

The SWPP Plan shall describe the storm water management controls appropriate for the facility and a time schedule for fully implementing such controls. The appropriateness and priorities of controls in the SWPP Plan shall reflect identified potential sources of pollutants. The description of storm water management controls to be implemented shall include, as appropriate:

a. Storm water pollution prevention personnel

Identify specific individuals (and job titles) that are responsible for developing, implementing, and reviewing the SWPP Plan.

b. Good housekeeping

Good housekeeping requires the maintenance of clean, orderly facility areas that discharge storm water. Material handling areas shall be inspected and cleaned to reduce the potential for pollutants to enter the storm drain conveyance system.

c. Spill prevention and response

Identify areas where significant materials can spill into or otherwise enter storm water conveyance systems and their accompanying drainage points. Specific material handling procedures, storage requirements, and cleanup equipment and procedures shall be identified, as appropriate. The necessary equipment to implement a cleanup shall be available, and personnel shall be trained in proper response, containment, and cleanup of spills. Internal reporting procedures for spills of significant materials shall be established.

d. Source control

Source controls include, for example, elimination or reduction of the use of toxic pollutants, covering of pollutant source areas, sweeping of paved areas, containment of potential pollutants, labeling of all storm drain inlets with “No Dumping” signs, isolation or separation of industrial and non-industrial pollutant sources so that runoff from these areas does not mix, etc.

e. Storm water management practices

Storm water management practices are practices other than those that control the sources of pollutants. Such practices include treatment or conveyance structures, such as drop inlets, channels, retention and detention basins, treatment vaults, infiltration galleries, filters, oil/water separators, etc. Based on assessment of the potential of various sources to contribute pollutants to storm water discharges in significant quantities, additional storm water management practices to remove pollutants from storm water discharges shall be implemented and design criteria shall be described.

f. Sediment and erosion control

Measures to minimize erosion around the storm water drainage and discharge points, such as riprap, revegetation, slope stabilization, etc., shall be described.

g. Employee training

Employee training programs shall inform all personnel responsible for implementing the SWPP Plan. Training shall address spill response, good housekeeping, and material management practices. New employee and refresher training schedules shall be identified.

h. Inspections

All inspections shall be done by trained personnel. Material handling areas shall be inspected for evidence of, or the potential for, pollutants entering storm water discharges. A tracking or follow up procedure shall be used to ensure appropriate response has been taken in response to an inspection. Inspections and maintenance activities shall be documented and recorded. Inspection records shall be retained for five years.

i. Records

A tracking and follow-up procedure shall be described to ensure that adequate response and corrective actions have been taken in response to inspections.

4. Annual Verification of SWPP Plan

An annual facility inspection shall be conducted to verify that all elements of the SWPP Plan are accurate and up-to-date. The results of this review shall be reported in the Annual Report to the Regional Water Board described in Section V.C.f.

K. Biosolids Management – This section is an addition to Standard Provisions (Attachment D)

Biosolids must meet the following requirements prior to land application. The Discharger must either demonstrate compliance or, if it sends the biosolids to another party for further treatment or distribution, must give the recipient the information necessary to ensure compliance.

1. Exceptional quality biosolids meet the pollutant concentration limits in Table III of 40 CFR Part 503.13, Class A pathogen limits, and one of the vector attraction reduction requirements in 503.33(b)(1)-(b)(8). Such biosolids do not have to be tracked further for compliance with general requirements (503.12) and management practices (503.14).
2. Biosolids used for agricultural land, forest, or reclamation shall meet the pollutant limits in Table I (ceiling concentrations) and Table II or Table III (cumulative loadings or pollutant concentration limits) of 503.13. They shall also meet the general requirements (503.12) and management practices (503.14) (if not exceptional quality biosolids) for Class A or Class B pathogen levels with associated access restrictions (503.32) and one of the 10 vector attraction reduction requirements in 503.33(b)(1)-(b)(10).
3. Biosolids used for lawn or home gardens must meet exceptional quality biosolids limits.
4. Biosolids sold or given away in a bag or other container must meet the pollutant limits in either Table III or Table IV (pollutant concentration limits or annual pollutant loading rate limits) of 503.13. If Table IV is used, a label or information sheet must be attached to the biosolids packing that explains Table IV (see 503.14). The biosolids must also meet the Class A pathogen limits and one of the vector attraction reduction requirements in 503.33(b)(1)-(b)(8).

II. STANDARD PROVISIONS – PERMIT ACTION – Not Supplemented

III. STANDARD PROVISIONS – MONITORING

A. Sampling and Analyses – This section is a supplement to III.A and III.B of Standard Provisions (Attachment D)

1. Use of Certified Laboratories

Water and waste analyses shall be performed by a laboratory certified for these analyses in accordance with California Water Code Section 13176.

2. Use of Appropriate Minimum Levels

Table C lists the suggested analytical methods for the 126 priority pollutants and other toxic pollutants that should be used, unless a particular method or minimum level (ML) is required in the MRP.

For priority pollutant monitoring, when there is more than one ML value for a given substance, the Discharger may select any one of the analytical methods cited in Table C for compliance determination, or any other method described in 40 CFR part 136 or approved by U.S. EPA (such as the 1600 series) if authorized by the Regional Water Board. However, the ML must be below the effluent limitation and water quality objective. If no ML value is below the effluent limitation and water quality objective, then the method must achieve an ML no greater than the lowest ML value indicated in Table C. All monitoring instruments and equipment shall be properly calibrated and maintained to ensure accuracy of measurements.

3. Frequency of Monitoring

The minimum schedule of sampling analysis is specified in the MRP portion of the permit.

a. Timing of Sample Collection

- 1) The Discharger shall collect samples of influent on varying days selected at random and shall not include any plant recirculation or other sidestream wastes, unless otherwise stipulated by the MRP.
- 2) The Discharger shall collect samples of effluent on days coincident with influent sampling unless otherwise stipulated by the MRP or the Executive Officer. The Executive Officer may approve an alternative sampling plan if it is demonstrated to be representative of plant discharge flow and in compliance with all other permit requirements.
- 3) The Discharger shall collect grab samples of effluent during periods of day-time maximum peak effluent flows (or peak flows through secondary treatment units for facilities that recycle effluent flows).
- 4) Effluent sampling for conventional pollutants shall occur on at least one day of any multiple-day bioassay test the MRP requires. During the course of the test, on at least one day, the Discharger shall collect and retain samples of the discharge. In the event a bioassay test does

not comply with permit limits, the Discharger shall analyze these retained samples for pollutants that could be toxic to aquatic life and for which it has effluent limits.

- i. The Discharger shall perform bioassay tests on final effluent samples; when chlorine is used for disinfection, bioassay tests shall be performed on effluent after chlorination-dechlorination; and
- ii. The Discharger shall analyze for total ammonia nitrogen and calculate the amount of un-ionized ammonia whenever test results fail to meet the percent survival specified in the permit.

b. Conditions Triggering Accelerated Monitoring

- 1) If the results from two consecutive samples of a constituent monitored in a 30-day period exceed the monthly average limit for any parameter (or if the required sampling frequency is once per month and the monthly sample exceeds the monthly average limit), the Discharger shall, within 24 hours after the results are received, increase its sampling frequency to daily until the results from the additional sampling show that the parameter is in compliance with the monthly average limit.
- 2) If any maximum daily limit is exceeded, the Discharger shall increase its sampling frequency to daily within 24 hours after the results are received that indicate the exceedance of the maximum daily limit until two samples collected on consecutive days show compliance with the maximum daily limit.
- 3) If final or intermediate results of an acute bioassay test indicate a violation or threatened violation (e.g., the percentage of surviving test organisms of any single acute bioassay test is less than 70 percent), the Discharger shall initiate a new test as soon as practical, and the Discharger shall investigate the cause of the mortalities and report its findings in the next self monitoring report (SMR).
- 4) The Discharger shall calibrate chlorine residual analyzers against grab samples as frequently as necessary to maintain accurate control and reliable operation. If an effluent violation is detected, the Discharger shall collect grab samples at least every 30 minutes until compliance with the limit is achieved, unless the Discharger monitors chlorine residual continuously. In such cases, the Discharger shall continue to conduct continuous monitoring as required by its permit.
- 5) When a bypass occurs (except one subject to provision III.A.3.b.6 below), the Discharger shall monitor flows and collect samples on a daily basis for all constituents at affected discharge points that have effluent limits for the duration of the bypass (including acute toxicity using static renewals), except chronic toxicity, unless otherwise stipulated by the MRP.
- 6) Unless otherwise stipulated by the MRP, when a bypass approved pursuant to Attachment D, Standard Provisions, Sections I.G.2 or I.G.4, occurs, the Discharger shall monitor flows and, using appropriate procedures as specified in the MRP, collect and retain samples for affected discharge points on a daily basis for the duration of the bypass. The Discharger shall analyze for total suspended solids (TSS) using 24-hour composites (or more frequent increments) and for bacteria indicators with effluent limits using grab samples. If TSS exceeds 45 mg/L in any composite sample, the Discharger shall also analyze the retained samples for that discharge for all other constituents that have effluent limits, except oil and grease, mercury, dioxin-

TEQ, and acute and chronic toxicity. Additionally, at least once each year, the Discharger shall analyze the retained samples for one approved bypass discharge event for all other constituents that have effluent limits, except oil and grease, mercury, dioxin-TEQ, and acute and chronic toxicity. This monitoring shall be in addition to the minimum monitoring specified in the MRP.

c. Storm Water Monitoring

The requirements of this section only apply to facilities that are not covered by an NPDES permit for storm water discharges and where not all site storm drainage from process areas (i.e., areas of the treatment facility where chemicals or wastewater could come in contact with storm water) is directed to the headworks. For storm water not directed to the headworks during the wet season (October 1 to April 30), the Discharger shall:

- 1) Conduct visual observations of the storm water discharge locations during daylight hours at least once per month during a storm event that produces significant storm water discharge to observe the presence of floating and suspended materials, oil and grease, discoloration, turbidity, and odor, etc.
- 2) Measure (or estimate) the total volume of storm water discharge, collect grab samples of storm water discharge from at least two storm events that produce significant storm water discharge, and analyze the samples for oil and grease, pH, TSS, and specific conductance.

The grab samples shall be taken during the first 30 minutes of the discharge. If collection of the grab samples during the first 30 minutes is impracticable, grab samples may be taken during the first hour of the discharge, and the Discharger shall explain in the Annual Report why the grab sample(s) could not be taken in the first 30 minutes.

- 3) Testing for the presence of non-storm water discharges shall be conducted no less than twice during the dry season (May 1 to September 30) at all storm water discharge locations. Tests may include visual observations of flows, stains, sludges, odors, and other abnormal conditions; dye tests; TV line surveys; or analysis and validation of accurate piping schematics. Records shall be maintained describing the method used, date of testing, locations observed, and test results.
- 4) Samples shall be collected from all locations where storm water is discharged. Samples shall represent the quality and quantity of storm water discharged from the facility. If a facility discharges storm water at multiple locations, the Discharger may sample a reduced number of locations if it establishes and documents through the monitoring program that storm water discharges from different locations are substantially identical.
- 5) Records of all storm water monitoring information and copies of all reports required by the permit shall be retained for a period of at least three years from the date of sample, observation, or report.

d. Receiving Water Monitoring

The requirements of this section only apply when the MRP requires receiving water sampling.

- 1) Receiving water samples shall be collected on days coincident with effluent sampling for conventional pollutants.
- 2) Receiving water samples shall be collected at each station on each sampling day during the period within one hour following low slack water. Where sampling during lower slack water is impractical, sampling shall be performed during higher slack water. Samples shall be collected within the discharge plume and down current of the discharge point so as to be representative, unless otherwise stipulated in the MRP.
- 3) Samples shall be collected within one foot of the surface of the receiving water, unless otherwise stipulated in the MRP.

B. Biosolids Monitoring – This section supplements III.B of Standard Provisions (Attachment D)

When biosolids are sent to a landfill, sent to a surface disposal site, or applied to land as a soil amendment, they must be monitored as follows:

1. Biosolids Monitoring Frequency

Biosolids disposal must be monitored at the following frequency:

<u>Metric tons biosolids/365 days</u>	<u>Frequency</u>
0-290	Once per year
290-1500	Quarterly
1500-15,000	Six times per year
Over 15,000	Once per month

(Metric tons are on a dry weight basis)

2. Biosolids Pollutants to Monitor

Biosolids shall be monitored for the following constituents:

- Land Application: Arsenic, cadmium, copper, mercury, molybdenum, nickel, lead, selenium, and zinc
- Municipal Landfill: Paint filter test (pursuant to 40 CFR 258)
- Biosolids-only Landfill or Surface Disposal Site (if no liner and leachate system): arsenic, chromium, and nickel

C. Standard Observations – This section is an addition to III of Standard Provisions (AttachmentD)

1. Receiving Water Observations

The requirements of this section only apply when the MRP requires standard observations of the receiving water. Standard observations shall include the following:

- a. *Floating and suspended materials* (e.g., oil, grease, algae, and other macroscopic particulate matter): presence or absence, source, and size of affected area.
- b. *Discoloration and turbidity*: description of color, source, and size of affected area.
- c. *Odor*: presence or absence, characterization, source, distance of travel, and wind direction.
- d. *Beneficial water use*: presence of water-associated waterfowl or wildlife, fisherpeople, and other recreational activities in the vicinity of each sampling station.
- e. *Hydrographic condition*: time and height of corrected high and low tides (corrected to nearest National Oceanic and Atmospheric Administration location for the sampling date and time of sample collection).
- f. *Weather conditions*:
 - 1) Air temperature; and
 - 2) Total precipitation during the five days prior to observation.

2. Wastewater Effluent Observations

The requirements of this section only apply when the MRP requires wastewater effluent standard observations. Standard observations shall include the following:

- a. *Floating and suspended material of wastewater origin* (e.g., oil, grease, algae, and other macroscopic particulate matter): presence or absence.
- b. *Odor*: presence or absence, characterization, source, distance of travel, and wind direction.

3. Beach and Shoreline Observations

The requirements of this section only apply when the MRP requires beach and shoreline standard observations. Standard observations shall include the following:

- a. *Material of wastewater origin*: presence or absence, description of material, estimated size of affected area, and source.
- b. *Beneficial use*: estimate number of people participating in recreational water contact, non-water contact, or fishing activities.

4. Land Retention or Disposal Area Observations

The requirements of this section only apply to facilities with on-site surface impoundments or disposal areas that are in use. This section applies to both liquid and solid wastes, whether confined or unconfined. The Discharger shall conduct the following for each impoundment:

- a. Determine the amount of freeboard at the lowest point of dikes confining liquid wastes.
- b. Report evidence of leaching liquid from area of confinement and estimated size of affected area. Show affected area on a sketch and volume of flow (e.g., gallons per minute [gpm]).

- c. Regarding odor, describe presence or absence, characterization, source, distance of travel, and wind direction.
- d. Estimate number of waterfowl and other water-associated birds in the disposal area and vicinity.

5. Periphery of Waste Treatment and/or Disposal Facilities Observations

The requirements of this section only apply when the MRP specifies periphery standard observations. Standard observations shall include the following:

- a. *Odor*: presence or absence, characterization, source, and distance of travel.
- b. *Weather conditions*: wind direction and estimated velocity.

IV. STANDARD PROVISIONS – RECORDS

A. Records to be Maintained – This supplements IV.A of Standard Provisions (Attachment D)

The Discharger shall maintain records in a manner and at a location (e.g., wastewater treatment plant or Discharger offices) such that the records are accessible to Regional Water Board staff. The minimum period of retention specified in Section IV, Records, of the Federal Standard Provisions shall be extended during the course of any unresolved litigation regarding the subject discharge, or when requested by the Regional Water Board or Regional Administrator of U.S. EPA, Region IX.

A copy of the permit shall be maintained at the discharge facility and be available at all times to operating personnel.

B. Records of monitoring information shall include – This supplements IV.B of Standard Provision (Attachment D)

1. Analytical Information

Records shall include analytical method detection limits, minimum levels, reporting levels, and related quantification parameters.

2. Flow Monitoring Data

For all required flow monitoring (e.g., influent and effluent flows), the additional records shall include the following, unless otherwise stipulated by the MRP:

- a. Total volume for each day; and
- b. Maximum, minimum, and average daily flows for each calendar month.

3. Wastewater Treatment Process Solids

- a. For each treatment unit process that involves solids removal from the wastewater stream, records shall include the following:
 - 1) Total volume or mass of solids removed from each collection unit (e.g., grit, skimmings, undigested biosolids, or combination) for each calendar month or other time period as appropriate, but not to exceed annually; and
 - 2) Final disposition of such solids (e.g., landfill, other subsequent treatment unit).
- b. For final dewatered biosolids from the treatment plant as a whole, records shall include the following:
 - 1) Total volume or mass of dewatered biosolids for each calendar month;
 - 2) Solids content of the dewatered biosolids; and
 - 3) Final disposition of dewatered biosolids (disposal location and disposal method).

4. Disinfection Process

For the disinfection process, these additional records shall be maintained documenting process operation and performance:

- a. For bacteriological analyses:
 - 1) Wastewater flow rate at the time of sample collection; and
 - 2) Required statistical parameters for cumulative bacterial values (e.g., moving median or geometric mean for the number of samples or sampling period identified in this Order).
- b. For the chlorination process, when chlorine is used for disinfection, at least daily average values for the following:
 - 1) Chlorine residual of treated wastewater as it enters the contact basin (mg/L);
 - 2) Chlorine dosage (kg/day); and
 - 3) Dechlorination chemical dosage (kg/day).

5. Treatment Process Bypasses

A chronological log of all treatment process bypasses, including wet weather blending, shall include the following:

- a. Identification of the treatment process bypassed;
- b. Dates and times of bypass beginning and end;
- c. Total bypass duration;

- d. Estimated total bypass volume; and
- e. Description of, or reference to other reports describing, the bypass event, the cause, the corrective actions taken (except for wet weather blending that is in compliance with permit conditions), and any additional monitoring conducted.

6. Treatment Facility Overflows

This section applies to records for overflows at the treatment facility. This includes the headworks and all units and appurtenances downstream. The Discharger shall retain a chronological log of overflows at the treatment facility and records supporting the information provided in section V.E.2.

C. Claims of Confidentiality – Not Supplemented

V. STANDARD PROVISIONS – REPORTING

A. Duty to Provide Information – Not Supplemented

B. Signatory and Certification Requirements – Not Supplemented

C. Monitoring Reports – This section supplements V.C of Standard Provisions (Attachment D)

1. Self Monitoring Reports

For each reporting period established in the MRP, the Discharger shall submit an SMR to the Regional Water Board in accordance with the requirements listed in this document and at the frequency the MRP specifies. The purpose of the SMR is to document treatment performance, effluent quality, and compliance with the waste discharge requirements of this Order.

a. Transmittal letter

Each SMR shall be submitted with a transmittal letter. This letter shall include the following:

- 1) Identification of all violations of effluent limits or other waste discharge requirements found during the reporting period;
- 2) Details regarding violations: parameters, magnitude, test results, frequency, and dates;
- 3) Causes of violations;
- 4) Discussion of corrective actions taken or planned to resolve violations and prevent recurrences, and dates or time schedule of action implementation (if previous reports have been submitted that address corrective actions, reference to the earlier reports is satisfactory);
- 5) Data invalidation (Data should not be submitted in an SMR if it does not meet quality assurance/quality control standards. However, if the Discharger wishes to invalidate any measurement after it was submitted in an SMR, a letter shall identify the measurement suspected to be invalid and state the Discharger's intent to submit, within 60 days, a formal request to invalidate the measurement. This request shall include the original measurement in question, the reason for invalidating the measurement, all relevant documentation that supports invalidation [e.g., laboratory sheet, log entry, test results, etc.], and discussion of the

corrective actions taken or planned [with a time schedule for completion] to prevent recurrence of the sampling or measurement problem.);

- 6) If the Discharger blends, the letter shall describe the duration of blending events and certify whether blended effluent was in compliance with the conditions for blending; and
- 7) Signature (The transmittal letter shall be signed according to Section V.B of this Order, Attachment D – Standard Provisions.).

b. Compliance evaluation summary

Each report shall include a compliance evaluation summary. This summary shall include each parameter for which the permit specifies effluent limits, the number of samples taken during the monitoring period, and the number of samples that exceed applicable effluent limits.

c. Results of analyses and observations

- 1) Tabulations of all required analyses and observations, including parameter, date, time, sample station, type of sample, test result, method detection limit, method minimum level, and method reporting level, if applicable, signed by the laboratory director or other responsible official.
- 2) When determining compliance with an average monthly effluent limitation and more than one sample result is available in a month, the Discharger shall compute the arithmetic mean unless the data set contains one or more reported determinations of detected but not quantified (DNQ) or nondetect (ND). In those cases, the Discharger shall compute the median in place of the arithmetic mean in accordance with the following procedure:
 - i. The data set shall be ranked from low to high, reported ND determinations lowest, DNQ determinations next, followed by quantified values (if any). The order of the individual ND or DNQ determinations is unimportant.
 - ii. The median value of the data set shall be determined. If the data set has an odd number of data points, then the median is the middle value. If the data set has an even number of data points, then the median is the average of the two values around the middle unless one or both of the points are ND or DNQ, in which case the median value shall be the lower of the two data points where DNQ is lower than a value and ND is lower than DNQ.

If a sample result, or the arithmetic mean or median of multiple sample results, is below the reporting limit, and there is evidence that the priority pollutant is present in the effluent above an effluent limitation and the Discharger conducts a Pollutant Minimization Program, the Discharger shall not be deemed out of compliance.

- 3) Dioxin-TEQ Reporting: The Discharger shall report for each dioxin and furan congener the analytical results of effluent monitoring, including the quantifiable limit (reporting level), the method detection limit, and the measured concentration. The Discharger shall report all measured values of individual congeners, including data qualifiers. When calculating dioxin-TEQ, the Discharger shall set congener concentrations below the minimum levels (ML) to zero. The Discharger shall calculate and report dioxin-TEQs using the following formula, where the MLs, toxicity equivalency factors (TEFs), and bioaccumulation equivalency factors (BEFs) are as provided in Table A:

$$\text{Dioxin-TEQ} = \Sigma (C_x \times \text{TEF}_x \times \text{BEF}_x)$$

where: C_x = measured or estimated concentration of congener x
 TEF_x = toxicity equivalency factor for congener x
 BEF_x = bioaccumulation equivalency factor for congener x

Table A
 Minimum Levels, Toxicity Equivalency Factors,
 and Bioaccumulation Equivalency Factors

Dioxin or Furan Congener	Minimum Level (pg/L)	1998 Toxicity Equivalency Factor (TEF)	Bioaccumulation Equivalency Factor (BEF)
2,3,7,8-TCDD	10	1.0	1.0
1,2,3,7,8-PeCDD	50	1.0	0.9
1,2,3,4,7,8-HxCDD	50	0.1	0.3
1,2,3,6,7,8-HxCDD	50	0.1	0.1
1,2,3,7,8,9-HxCDD	50	0.1	0.1
1,2,3,4,6,7,8-HpCDD	50	0.01	0.05
OCDD	100	0.0001	0.01
2,3,7,8-TCDF	10	0.1	0.8
1,2,3,7,8-PeCDF	50	0.05	0.2
2,3,4,7,8-PeCDF	50	0.5	1.6
1,2,3,4,7,8-HxCDF	50	0.1	0.08
1,2,3,6,7,8-HxCDF	50	0.1	0.2
1,2,3,7,8,9-HxCDF	50	0.1	0.6
2,3,4,6,7,8-HxCDF	50	0.1	0.7
1,2,3,4,6,7,8-HpCDF	50	0.01	0.01
1,2,3,4,7,8,9-HpCDF	50	0.01	0.4
OCDF	100	0.0001	0.02

d. Data reporting for results not yet available

The Discharger shall make all reasonable efforts to obtain analytical data for required parameter sampling in a timely manner. Certain analyses require additional time to complete analytical processes and report results. For cases where required monitoring parameters require additional time to complete analytical processes and reports, and results are not available in time to be included in the SMR for the subject monitoring period, the Discharger shall describe such circumstances in the SMR and include the data for these parameters and relevant discussions of any observed exceedances in the next SMR due after the results are available.

e. Flow data

The Discharger shall provide flow data tabulation pursuant to Section IV.B.2.

f. Annual self monitoring report requirements

By the date specified in the MRP, the Discharger shall submit an annual report to the Regional Water Board covering the previous calendar year. The report shall contain the following:

- 1) Annual compliance summary table of treatment plant performance, including documentation of any blending events;
- 2) Comprehensive discussion of treatment plant performance and compliance with the permit (This discussion shall include any corrective actions taken or planned, such as changes to facility equipment or operation practices that may be needed to achieve compliance, and any other actions taken or planned that are intended to improve performance and reliability of the Discharger's wastewater collection, treatment, or disposal practices.);
- 3) Both tabular and graphical summaries of the monitoring data for the previous year if parameters are monitored at a frequency of monthly or greater;
- 4) List of approved analyses, including the following:
 - (i) List of analyses for which the Discharger is certified;
 - (ii) List of analyses performed for the Discharger by a separate certified laboratory (copies of reports signed by the laboratory director of that laboratory shall not be submitted but be retained onsite); and
 - (iii) List of "waived" analyses, as approved;
- 5) Plan view drawing or map showing the Discharger's facility, flow routing, and sampling and observation station locations;
- 6) Results of annual facility inspection to verify that all elements of the SWPP Plan are accurate and up to date (only required if the Discharger does not route all storm water to the headworks of its wastewater treatment plant); and
- 7) Results of facility report reviews (The Discharger shall regularly review, revise, and update, as necessary, the O&M Manual, the Contingency Plan, the Spill Prevention Plan, and Wastewater Facilities Status Report so that these documents remain useful and relevant to current practices. At a minimum, reviews shall be conducted annually. The Discharger shall include, in each Annual Report, a description or summary of review and evaluation procedures, recommended or planned actions, and an estimated time schedule for implementing these actions. The Discharger shall complete changes to these documents to ensure they are up-to-date.).

g. Report submittal

The Discharger shall submit SMRs to:

California Regional Water Quality Control Board

San Francisco Bay Region
1515 Clay Street, Suite 1400
Oakland, CA 94612
Attn: NPDES Wastewater Division

h. Reporting data in electronic format

The Discharger has the option to submit all monitoring results in an electronic reporting format approved by the Executive Officer. If the Discharger chooses to submit SMRs electronically, the following shall apply:

- 1) *Reporting Method*: The Discharger shall submit SMRs electronically via a process approved by the Executive Officer (see, for example, the letter dated December 17, 1999, "Official Implementation of Electronic Reporting System [ERS]" and the progress report letter dated December 17, 2000).
- 2) *Monthly or Quarterly Reporting Requirements*: For each reporting period (monthly or quarterly as specified in the MRP), the Discharger shall submit an electronic SMR to the Regional Water Board in accordance with the provisions of Section V.C.1.a-e, except for requirements under Section V.C.1.c(1) where ERS does not have fields for dischargers to input certain information (e.g., sample time). However, until U.S. EPA approves the electronic signature or other signature technologies, dischargers that use ERS shall submit a hard copy of the original transmittal letter, an ERS printout of the data sheet, and a violation report (a receipt of the electronic transmittal shall be retained by the Discharger). This electronic SMR submittal suffices for the signed tabulations specified under Section V.C.1.c(1).
- 3) *Annual Reporting Requirements*: Dischargers who have submitted data using the ERS for at least one calendar year are exempt from submitting the portion of the annual report required under Section V.C.1.f(1) and (3).

D. Compliance Schedules – Not supplemented

E. Twenty-Four Hour Reporting – This section supplements V.E of Standard Provision (Attachment D)

1. Spill of Oil or Other Hazardous Material Reports

- a. Within 24 hours of becoming aware of a spill of oil or other hazardous material that is not contained onsite and completely cleaned up, the Discharger shall report by telephone to the Regional Water Board at (510) 622-2369.
- b. The Discharger shall also report such spills to the State Office of Emergency Services [telephone (800) 852-7550] only when the spills are in accordance with applicable reporting quantities for hazardous materials.
- c. The Discharger shall submit a written report to the Regional Water Board within five working days following telephone notification unless directed otherwise by Regional Water Board staff. A report submitted electronically is acceptable. The written report shall include the following:
 - 1) Date and time of spill, and duration if known;

- 2) Location of spill (street address or description of location);
 - 3) Nature of material spilled;
 - 4) Quantity of material involved;
 - 5) Receiving water body affected, if any;
 - 6) Cause of spill;
 - 7) Estimated size of affected area;
 - 8) Observed impacts to receiving waters (e.g., oil sheen, fish kill, water discoloration);
 - 9) Corrective actions taken to contain, minimize, or clean up the spill;
 - 10) Future corrective actions planned to be taken to prevent recurrence, and schedule of implementation; and
 - 11) Persons or agencies notified.
2. Unauthorized Discharges from Municipal Wastewater Treatment Plants¹

The following requirements apply to municipal wastewater treatment plants that experience an unauthorized discharge at their treatment facilities and are consistent with and supercede requirements imposed on the Discharger by the Executive Officer by letter of May 1, 2008, issued pursuant to California Water Code Section 13383.

a. Two (2)-Hour Notification

For any unauthorized discharges that result in a discharge to a drainage channel or a surface water, the Discharger shall, as soon as possible, but not later than two (2) hours after becoming aware of the discharge, notify the State Office of Emergency Services (telephone 800-852-7550), the local health officers or directors of environmental health with jurisdiction over the affected water bodies, and the Regional Water Board. The notification to the Regional Water Board shall be via the Regional Water Board's online reporting system at www.wbers.net, and shall include the following:

- 1) Incident description and cause;
- 2) Location of threatened or involved waterway(s) or storm drains;
- 3) Date and time the unauthorized discharge started;
- 4) Estimated quantity and duration of the unauthorized discharge (to the extent known), and the estimated amount recovered;

¹ California Code of Regulations, Title 23, Section 2250(b), defines an unauthorized discharge to be a discharge, not regulated by waste discharge requirements, of treated, partially treated, or untreated wastewater resulting from the intentional or unintentional diversion of wastewater from a collection, treatment or disposal system.

- 5) Level of treatment prior to discharge (e.g., raw wastewater, primary treated, undisinfected secondary treated, and so on); and
- 6) Identity of the person reporting the unauthorized discharge.

b. 24-hour Certification

Within 24 hours, the Discharger shall certify to the Regional Water Board, at www.wbers.net, that the State Office of Emergency Services and the local health officers or directors of environmental health with jurisdiction over the affected water bodies have been notified of the unauthorized discharge.

c. 5-Day Written Report

Within five business days, the Discharger shall submit a written report, via the Regional Water Board's online reporting system at www.wbers.net, that includes, in addition to the information required above, the following:

- 1) Methods used to delineate the geographical extent of the unauthorized discharge within receiving waters;
- 2) Efforts implemented to minimize public exposure to the unauthorized discharge;
- 3) Visual observations of the impacts (if any) noted in the receiving waters (e.g., fish kill, discoloration of water) and the extent of sampling if conducted;
- 4) Corrective measures taken to minimize the impact of the unauthorized discharge;
- 5) Measures to be taken to minimize the chances of a similar unauthorized discharge occurring in the future;
- 6) Summary of Spill Prevention Plan or O&M Manual modifications to be made, if necessary, to minimize the chances of future unauthorized discharges; and
- 7) Quantity and duration of the unauthorized discharge, and the amount recovered.

d. Communication Protocol

To clarify the multiple levels of notification, certification, and reporting, the current communication requirements for unauthorized discharges from municipal wastewater treatment plants are summarized in Table B that follows.

Table B
 Summary of Communication Requirements for Unauthorized Discharges¹ from
 Municipal Wastewater Treatment Plants

Discharger is required to:	Agency Receiving Information	Time frame	Method for Contact
1. Notify	California Emergency Management Agency (Cal EMA)	As soon as possible, but not later than 2 hours after becoming aware of the unauthorized discharge.	Telephone – (800) 852-7550 (obtain a control number from Cal EMA)
	Local health department	As soon as possible, but not later than 2 hours after becoming aware of the unauthorized discharge.	Depends on local health department
	Regional Water Board	As soon as possible, but not later than 2 hours after becoming aware of the unauthorized discharge.	Electronic ² www.wbers.net
2. Certify	Regional Water Board	As soon as possible, but not later than 24 hours after becoming aware of the unauthorized discharge.	Electronic ³ www.wbers.net
3. Report	Regional Water Board	Within 5 business days of	Electronic ⁴

¹ California Code of Regulations, Title 23, Section 2250(b), defines an unauthorized discharge to be a discharge, not regulated by waste discharge requirements, of treated, partially treated, or untreated wastewater resulting from the intentional or unintentional diversion of wastewater from a collection, treatment or disposal system.

² In the event that the Discharger is unable to provide online notification within 2 hours of becoming aware of an unauthorized discharge, it shall phone the Regional Water Board’s spill hotline at (510) 622-2369 and convey the same information contained in the notification form. In addition, within 3 business days of becoming aware of the unauthorized discharge, the Discharger shall enter the notification information into the Regional Water Board’s online system in electronic format.

³ In most instances, the 2-hour notification will also satisfy 24-hour certification requirements. This is because the notification form includes fields for documenting that OES and the local health department have been contacted. In other words, if the Discharger is able to complete all the fields in the notification form within 2 hours, certification requirements are also satisfied. In the event that the Discharger is unable to provide online certification within 24 hours of becoming aware of an unauthorized discharge, it shall phone the Regional Water Board’s spill hotline at (510) 622-2369 and convey the same information contained in the certification form. In addition, within 3 business days of becoming aware of the unauthorized discharge, the Discharger shall enter the certification information into the Regional Water Board’s online system in electronic format.

⁴ If the Discharger cannot satisfy the 5-day reporting requirements via the Regional Water Board’s online reporting system, it shall submit a written report (preferably electronically in pdf) to the

		becoming aware of the unauthorized discharge.	www.wbers.net
--	--	---	--

appropriate Regional Water Board case manager. In cases where the Discharger cannot satisfy the 5-day reporting requirements via the online reporting system, it must still complete the Regional Water Board's online reporting requirements within 15 calendar days of becoming aware of the unauthorized discharge.

F. Planned Changes – Not supplemented

G. Anticipated Noncompliance – Not supplemented

H. Other Noncompliance – Not supplemented

I. Other Information – Not supplemented

VI. STANDARD PROVISION – ENFORCEMENT – Not Supplemented

VII. ADDITIONAL PROVISIONS – NOTIFICATION LEVELS – Not Supplemented

VIII. DEFINITIONS – This section is an addition to Standard Provisions (Attachment D)

More definitions can be found in Attachment A of this NPDES Permit.

1. Arithmetic Calculations

- a. Geometric mean is the antilog of the log mean or the back-transformed mean of the logarithmically transformed variables, which is equivalent to the multiplication of the antilogarithms. The geometric mean can be calculated with either of the following equations:

$$\text{Geometric Mean} = \text{Anti log} \left(\frac{1}{N} \sum_{i=1}^N \text{Log}(C_i) \right)$$

or

$$\text{Geometric Mean} = (C_1 * C_2 * \dots * C_N)^{1/N}$$

Where “N” is the number of data points for the period analyzed and “C” is the concentration for each of the “N” data points.

- b. Mass emission rate is obtained from the following calculation for any calendar day:

$$\text{Mass emission rate (lb/day)} = \frac{8.345}{N} \sum_{i=1}^N Q_i C_i$$

$$\text{Mass emission rate (kg/day)} = \frac{3.785}{N} \sum_{i=1}^N Q_i C_i$$

In which “N” is the number of samples analyzed in any calendar day and “Q_i” and “C_i” are the flow rate (MGD) and the constituent concentration (mg/L) associated with each of the “N” grab samples that may be taken in any calendar day. If a composite sample is taken, “C_i” is the concentration measured in the composite sample and “Q_i” is the average flow rate occurring during the period over which the samples are composited. The daily concentration of a constituent measured over any calendar day shall be determined from the flow-weighted average of the same constituent in the combined waste streams as follows:

$$C_d = \text{Average daily concentration} = \frac{1}{Q_t} \sum_{i=1}^N Q_i C_i$$

In which “N” is the number of component waste streams and “Q” and “C” are the flow rate (MGD) and the constituent concentration (mg/L) associated with each of the “N” waste streams. “Q_t” is the total flow rate of the combined waste streams.

- c. Maximum allowable mass emission rate, whether for a 24-hour, weekly 7-day, monthly 30-day, or 6-month period, is a limitation expressed as a daily rate determined with the formulas in the paragraph above, using the effluent concentration limit specified in the permit for the period and the specified allowable flow.
- d. POTW removal efficiency is the ratio of pollutants removed by the treatment facilities to pollutants entering the treatment facilities (expressed as a percentage). The Discharger shall determine removal efficiencies using monthly averages (by calendar month unless otherwise specified) of pollutant concentration of influent and effluent samples collected at about the same time and using the following equation (or its equivalent):

$$\text{Removal Efficiency (\%)} = 100 \times [1 - (\text{Effluent Concentration} / \text{Influent Concentration})]$$

2. Biosolids means the solids, semi-liquid suspensions of solids, residues, screenings, grit, scum, and precipitates separated from or created in wastewater by the unit processes of a treatment system. It also includes, but is not limited to, all supernatant, filtrate, centrate, decantate, and thickener overflow and underflow in the solids handling parts of the wastewater treatment system.
3. Blending is the practice of recombining wastewater that has been biologically treated with wastewater that has bypassed around biological treatment units.
4. Bottom sediment sample is (1) a separate grab sample taken at each sampling station for the determination of selected physical-chemical parameters, or (2) four grab samples collected from different locations in the immediate vicinity of a sampling station while the boat is anchored and analyzed separately for macroinvertebrates.
5. Composite sample is a sample composed of individual grab samples collected manually or by an automatic sampling device on the basis of time or flow as specified in the MRP. For flow-based composites, the proportion of each grab sample included in the composite sample shall be within plus or minus five percent (+/-5%) of the representative flow rate of the waste stream being measured at the time of grab sample collection. Alternatively, equal volume grab samples may be individually analyzed with the flow-weighted average calculated by averaging flow-weighted ratios of each grab sample analytical result. Grab samples comprising time-based composite samples shall be collected at intervals not greater than those specified in the MRP. The quantity of each grab sample comprising a time-based composite sample shall be a set of flow proportional volumes as specified in the MRP. If a particular time-based or flow-based composite sampling protocol is not specified in the MRP, the Discharger shall determine and implement the most representative sampling protocol for the given parameter subject to Executive Officer approval.
6. Depth-integrated sample is defined as a water or waste sample collected by allowing a sampling device to fill during a vertical traverse in the waste or receiving water body being sampled. The Discharger shall collect depth-integrated samples in such a manner that the collected sample will be representative of the waste or water body at that sampling point.

7. Flow sample is an accurate measurement of the average daily flow volume using a properly calibrated and maintained flow measuring device.
8. Grab sample is an individual sample collected in a short period of time not exceeding 15 minutes. Grab samples represent only the condition that exists at the time the wastewater is collected.
9. Initial dilution is the process that results in the rapid and irreversible turbulent mixing of wastewater with receiving water around the point of discharge.
10. Overflow is the intentional or unintentional spilling or forcing out of untreated or partially treated wastes from a transport system (e.g., through manholes, at pump stations, and at collection points) upstream from the treatment plant headworks or from any part of a treatment plant facility.
11. Priority pollutants are those constituents referred to in 40 CFR Part 122 as promulgated in the Federal Register, Vol. 65, No. 97, Thursday, May 18, 2000, also known as the California Toxics Rule, the presence or discharge of which could reasonably be expected to interfere with maintaining designated uses.
12. Storm water means storm water runoff, snow melt runoff, and surface runoff and drainage. It excludes infiltration and runoff from agricultural land.
13. Toxic pollutant means any pollutant listed as toxic under federal Clean Water Act section 307(a)(1) or under 40 CFR 401.15.
14. Untreated waste is raw wastewater.
15. Waste, waste discharge, discharge of waste, and discharge are used interchangeably in the permit. The requirements of the permit apply to the entire volume of water, and the material therein, that is disposed of to surface and ground waters of the State of California.

Table C
 List of Monitoring Parameters and Analytical Methods

CTR No.	Pollutant/Parameter	Analytical Method ⁹	Minimum Levels ¹⁰ (µg/l)											
			GC	GCMS	LC	Color	FAA	GFAA	ICP	ICP MS	SPGFAA	HYD RIDE	CVAA	DCP
1.	Antimony	204.2					10	5	50	0.5	5	0.5		1000
2.	Arsenic	206.3				20		2	10	2	2	1		1000
3.	Beryllium						20	0.5	2	0.5	1			1000
4.	Cadmium	200 or 213					10	0.5	10	0.25	0.5			1000
5a.	Chromium (III)	SM 3500												
5b.	Chromium (VI)	SM 3500				10	5							1000
	Chromium (total) ¹¹	SM 3500					50	2	10	0.5	1			1000
6.	Copper	200.9					25	5	10	0.5	2			1000
7.	Lead	200.9					20	5	5	0.5	2			10,000
8.	Mercury	1631 (note) ¹²												
9.	Nickel	249.2					50	5	20	1	5			1000
10.	Selenium	200.8 or SM 3114B or C						5	10	2	5	1		1000
11.	Silver	272.2					10	1	10	0.25	2			1000
12.	Thallium	279.2					10	2	10	1	5			1000
13.	Zinc	200 or 289					20		20	1	10			
14.	Cyanide	SM 4500 CN ⁻ C or I				5								
15.	Asbestos (only required for dischargers to MUN waters) ¹³	0100.2 ¹⁴												
16.	2,3,7,8-TCDD and 17 congeners (Dioxin)	1613												
17.	Acrolein	603	2.0	5										
18.	Acrylonitrile	603	2.0	2										
19.	Benzene	602	0.5	2										

⁹ The suggested method is the U.S. EPA Method unless otherwise specified (SM = Standard Methods). The Discharger may use another U.S. EPA-approved or recognized method if that method has a level of quantification below the applicable water quality objective. Where no method is suggested, the Discharger has the discretion to use any standard method.

¹⁰ Minimum levels are from the *State Implementation Policy*. They are the concentration of the lowest calibration standard for that technique based on a survey of contract laboratories. Laboratory techniques are defined as follows: GC = Gas Chromatography; GCMS = Gas Chromatography/Mass Spectrometry; LC = High Pressure Liquid Chromatography; Color = Colorimetric; FAA = Flame Atomic Absorption; GFAA = Graphite Furnace Atomic Absorption; ICP = Inductively Coupled Plasma; ICPMS = Inductively Coupled Plasma/Mass Spectrometry; SPGFAA = Stabilized Platform Graphite Furnace Atomic Absorption (i.e., U.S. EPA 200.9); Hydride = Gaseous Hydride Atomic Absorption; CVAA = Cold Vapor Atomic Absorption; DCP = Direct Current Plasma.

¹¹ Analysis for total chromium may be substituted for analysis of chromium (III) and chromium (VI) if the concentration measured is below the lowest hexavalent chromium criterion (11 µg/l).

¹² The Discharger shall use ultra-clean sampling (U.S. EPA Method 1669) and ultra-clean analytical methods (U.S. EPA Method 1631) for mercury monitoring. The minimum level for mercury is 2 ng/l (or 0.002 µg/l).

¹³ MUN = Municipal and Domestic Supply. This designation, if applicable, is in the Findings of the permit.

¹⁴ Determination of Asbestos Structures over 10 [micrometers] in Length in Drinking Water Using MCE Filters, U.S. EPA 600/R-94-134, June 1994.

CTR No.	Pollutant/Parameter	Analytical Method ⁹	Minimum Levels ¹⁰ (µg/l)											
			GC	GCMS	LC	Color	FAA	GFAA	ICP	ICP MS	SPGFAA	HYD RIDE	CVAA	DCP
33.	Ethylbenzene	602	0.5	2										
39.	Toluene	602	0.5	2										
20.	Bromoform	601	0.5	2										
21.	Carbon Tetrachloride	601	0.5	2										
22.	Chlorobenzene	601	0.5	2										
23.	Chlorodibromomethane	601	0.5	2										
24.	Chloroethane	601	0.5	2										
25.	2-Chloroethylvinyl Ether	601	1	1										
26.	Chloroform	601	0.5	2										
75.	1,2-Dichlorobenzene	601	0.5	2										
76.	1,3-Dichlorobenzene	601	0.5	2										
77.	1,4-Dichlorobenzene	601	0.5	2										
27.	Dichlorobromomethane	601	0.5	2										
28.	1,1-Dichloroethane	601	0.5	1										
29.	1,2-Dichloroethane	601	0.5	2										
30.	1,1-Dichloroethylene or 1,1-Dichloroethene	601	0.5	2										
31.	1,2-Dichloropropane	601	0.5	1										
32.	1,3-Dichloropropylene or 1,3-Dichloropropene	601	0.5	2										
34.	Methyl Bromide or Bromomethane	601	1.0	2										
35.	Methyl Chloride or Chloromethane	601	0.5	2										
36.	Methylene Chloride or Dichloromethane	601	0.5	2										
37.	1,1,2,2-Tetrachloroethane	601	0.5	1										
38.	Tetrachloroethylene	601	0.5	2										
40.	1,2-Trans-Dichloroethylene	601	0.5	1										
41.	1,1,1-Trichloroethane	601	0.5	2										
42.	1,1,2-Trichloroethane	601	0.5	2										
43.	Trichloroethene	601	0.5	2										
44.	Vinyl Chloride	601	0.5	2										
45.	2-Chlorophenol	604	2	5										
46.	2,4-Dichlorophenol	604	1	5										
47.	2,4-Dimethylphenol	604	1	2										
48.	2-Methyl-4,6-Dinitrophenol or Dinitro-2-methylphenol	604	10	5										
49.	2,4-Dinitrophenol	604	5	5										
50.	2-Nitrophenol	604		10										
51.	4-Nitrophenol	604	5	10										
52.	3-Methyl-4-Chlorophenol	604	5	1										
53.	Pentachlorophenol	604	1	5										
54.	Phenol	604	1	1		50								
55.	2,4,6-Trichlorophenol	604	10	10										
56.	Acenaphthene	610 HPLC	1	1	0.5									
57.	Acenaphthylene	610 HPLC		10	0.2									
58.	Anthracene	610 HPLC		10	2									
60.	Benzo(a)Anthracene or 1,2 Benzanthracene	610 HPLC	10	5										
61.	Benzo(a)Pyrene	610 HPLC		10	2									
62.	Benzo(b)Fluoranthene or 3,4 Benzofluoranthene	610 HPLC		10	10									
63.	Benzo(ghi)Perylene	610 HPLC		5	0.1									

CTR No.	Pollutant/Parameter	Analytical Method ⁹	Minimum Levels ¹⁰ (µg/l)											
			GC	GCMS	LC	Color	FAA	GFAA	ICP	ICP MS	SPGFAA	HYD RIDE	CVAA	DCP
64.	Benzo(k)Fluoranthene	610 HPLC		10	2									
74.	Dibenzo(a,h)Anthracene	610 HPLC		10	0.1									
86.	Fluoranthene	610 HPLC	10	1	0.05									
87.	Fluorene	610 HPLC		10	0.1									
92.	Indeno(1,2,3-cd) Pyrene	610 HPLC		10	0.05									
100.	Pyrene	610 HPLC		10	0.05									
68.	Bis(2-Ethylhexyl)Phthalate	606 or 625	10	5										
70.	Butylbenzyl Phthalate	606 or 625	10	10										
79.	Diethyl Phthalate	606 or 625	10	2										
80.	Dimethyl Phthalate	606 or 625	10	2										
81.	Di-n-Butyl Phthalate	606 or 625		10										
84.	Di-n-Octyl Phthalate	606 or 625		10										
59.	Benzidine	625		5										
65.	Bis(2-Chloroethoxy)Methane	625		5										
66.	Bis(2-Chloroethyl)Ether	625	10	1										
67.	Bis(2-Chloroisopropyl)Ether	625	10	2										
69.	4-Bromophenyl Phenyl Ether	625	10	5										
71.	2-Chloronaphthalene	625		10										
72.	4-Chlorophenyl Phenyl Ether	625		5										
73.	Chrysene	625		10	5									
78.	3,3'-Dichlorobenzidine	625		5										
82.	2,4-Dinitrotoluene	625	10	5										
83.	2,6-Dinitrotoluene	625		5										
85.	1,2-Diphenylhydrazine (note) ¹⁵	625		1										
88.	Hexachlorobenzene	625	5	1										
89.	Hexachlorobutadiene	625	5	1										
90.	Hexachlorocyclopentadiene	625	5	5										
91.	Hexachloroethane	625	5	1										
93.	Isophorone	625	10	1										
94.	Naphthalene	625	10	1	0.2									
95.	Nitrobenzene	625	10	1										
96.	N-Nitrosodimethylamine	625	10	5										
97.	N-Nitrosodi-n-Propylamine	625	10	5										
98.	N-Nitrosodiphenylamine	625	10	1										
99.	Phenanthrene	625		5	0.05									
101.	1,2,4-Trichlorobenzene	625	1	5										
102.	Aldrin	608	0.005											
103.	α-BHC	608	0.01											
104.	β-BHC	608	0.005											
105.	γ-BHC (Lindane)	608	0.02											
106.	δ-BHC	608	0.005											
107.	Chlordane	608	0.1											
108.	4,4'-DDT	608	0.01											
109.	4,4'-DDE	608	0.05											
110.	4,4'-DDD	608	0.05											
111.	Dieldrin	608	0.01											

¹⁵ Measurement for 1,2-Diphenylhydrazine may use azobenzene as a screen: if azobenzene is measured at >1 ug/l, then the Discharger shall analyze for 1,2-Diphenylhydrazine.

CTR No.	Pollutant/Parameter	Analytical Method ⁹	Minimum Levels ¹⁰ (µg/l)											
			GC	GCMS	LC	Color	FAA	GFAA	ICP	ICP MS	SPGFAA	HYD RIDE	CVAA	DCP
112.	Endosulfan (alpha)	608	0.02											
113.	Endosulfan (beta)	608	0.01											
114.	Endosulfan Sulfate	608	0.05											
115.	Endrin	608	0.01											
116.	Endrin Aldehyde	608	0.01											
117.	Heptachlor	608	0.01											
118.	Heptachlor Epoxide	608	0.01											
119-125	PCBs: Aroclors 1016, 1221, 1232, 1242, 1248, 1254, 1260	608	0.5											
126.	Toxaphene	608	0.5											