

**CALIFORNIA REGIONAL WATER QUALITY CONTROL BOARD  
CENTRAL VALLEY REGION**

11020 Sun Center Drive, #200 Rancho Cordova, California 95670-6114

Phone (916) 464-3291 • Fax (916) 464-4645

[Central Valley Home Page](http://www.waterboards.ca.gov/centralvalley) (<http://www.waterboards.ca.gov/centralvalley>)

**NATIONAL POLLUTANT DISCHARGE ELIMINATION SYSTEM (NPDES) CA0077895  
ORDER R5-2021-0007**

**WASTE DISCHARGE REQUIREMENTS FOR  
REGENTS, UNIVERSITY OF CALIFORNIA  
UNIVERSITY OF CALIFORNIA, DAVIS WASTEWATER TREATMENT PLANT  
SOLANO AND YOLO COUNTIES**

The following Discharger is subject to waste discharge requirements (WDRs) set forth in this Order:

**Table 1. Discharger Information**

Discharger:	Regents, University of California
Name of Facility:	University of California, Davis Wastewater Treatment Plant
Facility Street Address:	561 Trotter Way
Facility City, State, Zip:	Davis, CA 95616
Facility County:	Solano and Yolo Counties

**Table 2. Discharge Location**

Discharge Point	Effluent Description	Discharge Point Latitude (North)	Discharge Point Longitude (West)	Receiving Water
001	Tertiary treated municipal wastewater	38° 31' 2.7" N	121° 45' 26.7" W	South Fork of Putah Creek
002	Tertiary treated municipal wastewater	38° 31' 56.3" N	121° 45' 23.2" W	Arboretum Waterway

**Table 3. Administrative Information**

This Order was Adopted on:	<b>18 February 2021</b>
This Order shall become effective on:	<b>1 April 2021</b>
This Order shall expire on:	<b>31 March 2026</b>
The Discharger shall file a Report of Waste Discharge (ROWD) as an application for reissuance of WDRs in accordance with title 23, California Code of Regulations, and an application for reissuance of a NPDES permit no later than:	<b>31 March 2025</b>
The United States Environmental Protection Agency (U.S. EPA) and the California Regional Water Quality Control Board, Central Valley Region have classified this discharge as follows:	<b>Major Discharge</b>

I, Patrick Pulupa, Executive Officer, do hereby certify that this Order with all attachments is a full, true, and correct copy of the Order adopted by the California Regional Water Quality Control Board, Central Valley Region, on **18 February 2021**.

\_\_\_\_\_  
**PATRICK PULUPA**, Executive Officer

**WASTE DISCHARGE REQUIREMENTS  
 TABLE OF CONTENTS**

I.	Facility Information .....	3
II.	Findings .....	3
III.	Discharge Prohibitions.....	4
IV.	Effluent Limitations and Discharge Specifications .....	5
	A. Effluent Limitations – Discharge Points 001 and 002.....	5
	1. Final Effluent Limitations – Discharge Points 001 and 002 .....	5
	2. Interim Effluent Limitation .....	6
	B. Land Discharge Specifications – Not Applicable.....	6
	C. Recycling Specifications – Not Applicable .....	6
V.	Receiving Water Limitations .....	6
	A. Surface Water Limitations.....	6
	B. Groundwater Limitations .....	9
VI.	Provisions.....	9
	A. Standard Provisions.....	9
	B. Monitoring and Reporting Program Requirements.....	13
	C. Special Provisions.....	13
	1. Reopener Provisions.....	13
	2. Special Studies, Technical Reports and Additional Monitoring Requirements .....	15
	3. Best Management Practices and Pollution Prevention .....	16
	4. Construction, Operation and Maintenance Specifications.....	17
	5. Special Provisions for Publicly-Owned Treatment Works (POTWs) .....	18
	6. Other Special Provisions.....	20
	7. Compliance Schedules .....	20
VII.	Compliance Determination .....	20

**TABLES**

Table 1.	Discharger Information .....	1
Table 2.	Discharge Location .....	1
Table 3.	Administrative Information .....	1
Table 4.	Effluent Limitations .....	5

**ATTACHMENTS**

Attachment A – Definitions .....	A-1
Attachment B – Map .....	B-1
Attachment C – Flow Schematic.....	C-1
Attachment D – Standard Provisions.....	D-1
Attachment E – Monitoring and Reporting Program .....	E-1
Attachment F – Fact Sheet.....	F-1
Attachment G – Summary Of Reasonable Potential Analysis .....	G-1
Attachment H – Calculation of WQBELS .....	H-1

## I. FACILITY INFORMATION

Information describing the University of California, Davis Wastewater Treatment Plant (Facility) is summarized in Table 1, and in sections I and II, of the Fact Sheet (Attachment F). Section I of the Fact Sheet also includes information regarding the Facility's permit application.

## II. FINDINGS

The California Regional Water Quality Control Board, Central Valley Region (hereinafter Central Valley Water Board), finds:

- A. Legal Authorities.** This Order serves as waste discharge requirements (WDRs) pursuant to article 4, chapter 4, division 7 of the California Water Code (commencing with section 13260). This Order is also issued pursuant to section 402 of the federal Clean Water Act (CWA) and implementing regulations adopted by the U.S. EPA and chapter 5.5, division 7 of the Water Code (commencing with section 13370). It shall serve as a National Pollutant Discharge Elimination System (NPDES) permit authorizing the Discharger to discharge into waters of the United States at the discharge location described in Table 2 subject to the WDRs in this Order.
- B. California Environmental Quality Act (CEQA).** Under Water Code section 13389, this action to adopt an NPDES permit is exempt from the provisions of Chapter 3 of CEQA, (commencing with section 21100) of Division 13 of Public Resources Code.
- C. Background and Rationale for Requirements.** The Central Valley Water Board developed the requirements in this Order based on information submitted as part of the application, through monitoring and reporting programs, and other available information. The Fact Sheet (Attachment F), which contains background information and rationale for the requirements in this Order, is hereby incorporated into and constitutes Findings for this Order. Attachments A through E and G through H are also incorporated into this Order.
- D. Provisions and Requirements Implementing State Law.** The provisions/requirements in subsections V.B, VI.C.4, and VI.C.6 are included to implement state law only. These provisions/requirements are not required or authorized under the federal CWA; consequently, violations of these provisions/requirements are not subject to the enforcement remedies that are available for NPDES violations.
- E. Monitoring and Reporting.** 40 C.F.R. section 122.48 requires that all NPDES permits specify requirements for recording and reporting monitoring results. Water Code sections 13267 and 13383 authorize the Central Valley Water Board to require technical and monitoring reports. The Monitoring and Reporting Program (MRP) establishes monitoring and reporting requirements to implement federal and State requirements. The MRP is provided in Attachment E.

The technical and monitoring reports in this Order are required in accordance with Water Code section 13267, which states the following in subsection (b)(1), "In

conducting an investigation specified in subdivision (a), the regional board may require that any person who has discharged, discharges, or is suspected of having discharged discharging, or who proposes to discharge waste within its region, or any citizen or domiciliary, or political agency or entity of this state who has discharged, discharges, or is suspected of having discharged or discharging, or who proposes to discharge, waste outside of its region could affect the quality of waters within its region shall furnish, under penalty of perjury, technical or monitoring program reports which the regional board requires. The burden, including costs, of these reports shall bear a reasonable relationship to the need for the report and the benefits to be obtained from the reports. In requiring those reports, the regional board shall provide the person with a written explanation with regard to the need for the reports and shall identify the evidence that supports requiring that person to provide the reports.”

The Discharger owns and operates the Facility subject to this Order. The monitoring reports required by this Order are necessary to determine compliance with this Order. The need for the monitoring reports is discussed in the Fact Sheet.

- F. Notification of Interested Persons.** The Central Valley Water Board has notified the Discharger and interested agencies and persons of its intent to prescribe WDRs for the discharge and has provided them with an opportunity to submit their written comments and recommendations. Details of the notification are provided in the Fact Sheet.
- G. Consideration of Public Comment.** The Central Valley Water Board, in a public meeting, heard and considered all comments pertaining to the discharge. Details of the Public Hearing are provided in the Fact Sheet.

THEREFORE, IT IS HEREBY ORDERED that Order R5-2014-0152 is rescinded upon the effective date of this Order except for enforcement purposes, and, in order to meet the provisions contained in division 7 of the Water Code (commencing with section 13000) and regulations adopted thereunder, and the provisions of the CWA and regulations and guidelines adopted thereunder, the Discharger shall comply with the requirements in this Order. This action in no way prevents the Central Valley Water Board from taking enforcement action for violations of the previous Order.

### III. DISCHARGE PROHIBITIONS

- A.** Discharge of wastewater from the Facility, as the Facility is specifically described in the Fact Sheet in section II.B, in a manner different from that described in this Order is prohibited.
- B.** The by-pass or overflow of wastes to surface waters is prohibited, except as allowed by Federal Standard Provisions I.G. and I.H. (Attachment D).
- C.** Neither the discharge nor its treatment shall create a nuisance as defined in section 13050 of the Water Code.

- D. Discharge of waste classified as ‘hazardous’, as defined in the California Code of Regulations, title 22, section 66261.1 et seq., is prohibited.
- E. **Average Dry Weather Flow.** Discharges exceeding an average dry weather flow of 3.6 million gallons per day (MGD) are prohibited.

**IV. EFFLUENT LIMITATIONS AND DISCHARGE SPECIFICATIONS**

**A. Effluent Limitations – Discharge Points 001 and 002**

**1. Final Effluent Limitations – Discharge Points 001 and 002**

The Discharger shall maintain compliance with the following effluent limitations at Discharge Points 001 and 002. Unless otherwise specified, compliance shall be measured at Monitoring Location EFF-001, as described in the MRP, Attachment E:

- a. The Discharger shall maintain compliance with the effluent limitations specified in Table 4:

**Table 4. Effluent Limitations**

Parameters	Units	Average Monthly	Average Weekly
Biochemical Oxygen Demand, 5-day @ 20°Celsius (BOD <sub>5</sub> )	milligrams per liter (mg/L)	10	15
Total Suspended Solids (TSS)	mg/L	10	15
Ammonia Nitrogen, Total (as N) (1 May – 31 October)	mg/L	0.51	1.8
Ammonia Nitrogen, Total (as N) (1 May – 31 October)	lbs/day	16	55
Ammonia Nitrogen, Total (as N) (1 November – 30 April)	mg/L	1.1	3.3
Ammonia Nitrogen, Total (as N) (1 November – 30 April)	lbs/day	34	100
Nitrate plus Nitrite (as N)	mg/L	10	15

**Table 4 Note:**

Note 1. Mass in pounds per day (lbs/day) is based on the average dry weather flow of 3.6 million gallons per day (MGD).

- b. **pH:**
  - i. 6.5 standard units as an instantaneous minimum.
  - ii. 8.5 standard units as an instantaneous maximum.
- c. **Percent Removal:** The average monthly percent removal of BOD<sub>5</sub> and TSS shall not be less than 85 percent.
- d. **Acute Whole Effluent Toxicity.** Survival of aquatic organisms in 96-hour bioassays of undiluted waste shall be no less than:
  - i. 70%, minimum for any one bioassay; and

- ii. 90%, median for any three consecutive bioassays.
- e. **Chronic Whole Effluent Toxicity - Effective 1 April 2028.** The effluent chronic toxicity shall not exceed 1 chronic toxicity units (as 100/NOEC) AND a percent effect of 25 percent (%) at 100 percent (%) effluent, for any endpoint as the median of up to three consecutive chronic toxicity tests within a six-week period.
- f. **Total Coliform Organisms.** Effluent total coliform organisms shall not exceed the following with compliance measured at Monitoring Location UVS-002 as described in the MRP, Attachment E:
  - i. 2.2 most probable number per 100 milliliter (MPN/100 mL), as a 7-day median.
  - ii. 23 MPN/100 mL, more than once in any 30-day period; and
  - iii. 240 MPN/100 mL, at any time.
- g. **Mercury, Total.** For a calendar year, the total annual mass discharge of total mercury shall not exceed 0.015 pounds.
- h. **Electrical Conductivity @ 25°Celsius.** For a calendar year, the calendar average annual electrical conductivity concentration shall not exceed 1,300 µmhos/cm.

## 2. Interim Effluent Limitation

The Discharger shall maintain compliance with the following interim effluent limitation at Discharge Points 001 and 002, with compliance measured at Monitoring Location EFF-001 as described in the MRP, Attachment E:

- a. **Chronic Whole Effluent Toxicity.** Effective immediately and until **31 March 2028**, the effluent chronic toxicity shall not exceed 16 TUc (as 100/NOEC) AND a percent effect of 25 percent at 6.25 percent effluent, for any endpoint as the median of up to three consecutive chronic toxicity tests within a 6-week period. This interim effluent limitation shall apply in lieu of the corresponding final effluent limitation for chronic whole effluent toxicity as specified in section IV.A.1.e until **31 March 2028**.

### B. Land Discharge Specifications – Not Applicable

### C. Recycling Specifications – Not Applicable

## V. RECEIVING WATER LIMITATIONS

### A. Surface Water Limitations

The discharge shall not cause the following in the South Fork of Putah Creek or the Arboretum Waterway:

1. **Biostimulatory Substances.** Water to contain biostimulatory substances which promote aquatic growths in concentrations that cause nuisance or adversely affect beneficial uses.
2. **Chemical Constituents.** Chemical constituents to be present in concentrations that adversely affect beneficial uses.
3. **Color.** Discoloration that causes nuisance or adversely affects beneficial uses.
4. **Dissolved Oxygen:**
  - a. The monthly median of the mean daily dissolved oxygen concentration to fall below 85 percent of saturation in the main water mass;
  - b. The 95-percentile dissolved oxygen concentration to fall below 75 percent of saturation; nor
  - c. The dissolved oxygen concentration to be reduced below 7.0 mg/L at any time.
5. **Floating Material.** Floating material to be present in amounts that cause nuisance or adversely affect beneficial uses.
6. **Oil and Grease.** Oils, greases, waxes, or other materials to be present in concentrations that cause nuisance, result in a visible film or coating on the surface of the water or on objects in the water, or otherwise adversely affect beneficial uses.
7. **pH.** The pH to be depressed below 6.5 nor raised above 8.5.
8. **Pesticides:**
  - a. Pesticides to be present, individually or in combination, in concentrations that adversely affect beneficial uses;
  - b. Pesticides to be present in bottom sediments or aquatic life in concentrations that adversely affect beneficial uses;
  - c. Total identifiable persistent chlorinated hydrocarbon pesticides to be present in the water column at concentrations detectable within the accuracy of analytical methods approved by U.S. EPA or the Executive Officer;
  - d. Pesticide concentrations to exceed those allowable by applicable antidegradation policies (see State Water Board Resolution No. 68-16 and 40 CFR section 131.12.);
  - e. Pesticide concentrations to exceed the lowest levels technically and economically achievable;

- f. Pesticides to be present in concentration in excess of the maximum contaminant levels (MCL's) set forth in CCR, Title 22, division 4, chapter 15; nor
  - g. Thiobencarb to be present in excess of 1.0 µg/L.
9. **Radioactivity:**
- a. Radionuclides to be present in concentrations that are harmful to human, plant, animal, or aquatic life nor that result in the accumulation of radionuclides in the food web to an extent that presents a hazard to human, plant, animal, or aquatic life.
  - b. Radionuclides to be present in excess of the MCL's specified in Table 64442 of section 64442 and Table 64443 of section 64443 of Title 22 of the California Code of Regulations.
10. **Suspended Sediments.** The suspended sediment load and suspended sediment discharge rate of surface waters to be altered in such a manner as to cause nuisance or adversely affect beneficial uses.
11. **Settleable Substances.** Substances to be present in concentrations that result in the deposition of material that causes nuisance or adversely affects beneficial uses.
12. **Suspended Material.** Suspended material to be present in concentrations that cause nuisance or adversely affect beneficial uses.
13. **Taste and Odors.** Taste- or odor-producing substances to be present in concentrations that impart undesirable tastes or odors to fish flesh or other edible products of aquatic origin, or that cause nuisance, or otherwise adversely affect beneficial uses.
14. **Temperature.** The natural temperature to be increased by more than 5° Fahrenheit. Compliance to be determined based on the difference in temperature at Monitoring Locations RSW-U and RSW-D.
15. **Toxicity.** Toxic substances to be present, individually or in combination, in concentrations that produce detrimental physiological responses in human, plant, animal, or aquatic life.
16. **Turbidity.**
- a. Shall not exceed 2 Nephelometric Turbidity Units (NTU) where natural turbidity is less than 1 NTU;
  - b. Shall not increase more than 1 NTU where natural turbidity is between 1 and 5 NTUs;
  - c. Shall not increase more than 20 percent where natural turbidity is between 5 and 50 NTUs;



- d. Shall not increase more than 10 NTU where natural turbidity is between 50 and 100 NTUs; nor
- e. Shall not increase more than 10 percent where natural turbidity is greater than 100 NTUs.

**B. Groundwater Limitations**

- 1. Release of waste constituents from any storage, treatment, or disposal component associated with the WWTP, in combination with other sources, shall not cause the underlying groundwater to contain waste constituents in concentrations greater than background water quality or water quality objectives, whichever is greater. The discharge shall not cause the groundwater to exceed water quality objectives, unreasonably affect beneficial uses, or cause a condition of pollution or nuisance.

**VI. PROVISIONS**

**A. Standard Provisions**

- 1. The Discharger shall comply with all Standard Provisions included in Attachment D.
- 2. The Discharger shall comply with the following provisions. In the event that there is any conflict, duplication, or overlap between provisions specified by this Order, the more stringent provision shall apply:
  - a. If the Discharger's wastewater treatment plant is publicly owned or subject to regulation by California Public Utilities Commission, it shall be supervised and operated by persons possessing certificates of appropriate grade according to Title 23, CCR, division 3, chapter 26.
  - b. After notice and opportunity for a hearing, this Order may be terminated or modified for cause, including, but not limited to:
    - i. violation of any term or condition contained in this Order;
    - ii. obtaining this Order by misrepresentation or by failing to disclose fully all relevant facts;
    - iii. a change in any condition that requires either a temporary or permanent reduction or elimination of the authorized discharge; and
    - iv. a material change in the character, location, or volume of discharge.The causes for modification include:
    - i. New regulations. New regulations have been promulgated under section 405(d) of the CWA, or the standards or regulations on which the permit was based have been changed by promulgation of amended standards or regulations or by judicial decision after the permit was issued.

- ii. Land application plans. When required by a permit condition to incorporate a land application plan for beneficial reuse of sewage sludge, to revise an existing land application plan, or to add a land application plan.
- iii. Change in sludge use or disposal practice. Under 40 CFR section 122.62(a)(1), a change in the Discharger's sludge use or disposal practice is a cause for modification of the permit. It is cause for revocation and reissuance if the Discharger requests or agrees.

The Central Valley Water Board may review and revise this Order at any time upon application of any affected person or the Central Valley Water Board's own motion.

- c. If a toxic effluent standard or prohibition (including any scheduled compliance specified in such effluent standard or prohibition) is established under section 307(a) of the CWA, or amendments thereto, for a toxic pollutant that is present in the discharge authorized herein, and such standard or prohibition is more stringent than any limitation upon such pollutant in this Order, the Central Valley Water Board will revise or modify this Order in accordance with such toxic effluent standard or prohibition.

The Discharger shall comply with effluent standards and prohibitions within the time provided in the regulations that establish those standards or prohibitions, even if this Order has not yet been modified.

- d. This Order shall be modified, or alternately revoked and reissued, to comply with any applicable effluent standard or limitation issued or approved under sections 301(b)(2)(C) and (D), 304(b)(2), and 307(a)(2) of the CWA, if the effluent standard or limitation so issued or approved:
  - i. Contains different conditions or is otherwise more stringent than any effluent limitation in the Order; or
  - ii. Controls any pollutant limited in the Order.

The Order, as modified or reissued under this paragraph, shall also contain any other requirements of the CWA then applicable.

- e. The provisions of this Order are severable. If any provision of this Order is found invalid, the remainder of this Order shall not be affected.
- f. The Discharger shall take all reasonable steps to minimize any adverse effects to waters of the State or users of those waters resulting from any discharge or sludge use or disposal in violation of this Order. Reasonable steps shall include such accelerated or additional monitoring as necessary to determine the nature and impact of the non-complying discharge or sludge use or disposal.

- g. The Discharger shall ensure compliance with any existing or future pretreatment standard promulgated by U.S. EPA under section 307 of the CWA, or amendment thereto, for any discharge to the municipal system.
- h. A copy of this Order shall be maintained at the discharge Facility and be available at all times to operating personnel. Key operating personnel shall be familiar with its content.
- i. Safeguard to electric power failure:
  - i. The Discharger shall provide safeguards to assure that, should there be reduction, loss, or failure of electric power, the discharge shall comply with the terms and conditions of this Order.
  - ii. Upon written request by the Central Valley Water Board, the Discharger shall submit a written description of safeguards. Such safeguards may include alternate power sources, standby generators, retention capacity, operating procedures, or other means. A description of the safeguards provided shall include an analysis of the frequency, duration, and impact of power failures experienced over the past 5 years on effluent quality and on the capability of the Discharger to comply with the terms and conditions of the Order. The adequacy of the safeguards is subject to the approval of the Central Valley Water Board.
  - iii. Should the treatment works not include safeguards against reduction, loss, or failure of electric power, or should the Central Valley Water Board not approve the existing safeguards, the Discharger shall, within 90 days of having been advised in writing by the Central Valley Water Board that the existing safeguards are inadequate, provide to the Central Valley Water Board and U.S. EPA a schedule of compliance for providing safeguards such that in the event of reduction, loss, or failure of electric power, the Discharger shall comply with the terms and conditions of this Order. The schedule of compliance shall, upon approval of the Central Valley Water Board, become a condition of this Order.
- j. The Discharger, upon written request of the Central Valley Water Board, shall file with the Board a technical report on its preventive (failsafe) and contingency (cleanup) plans for controlling accidental discharges, and for minimizing the effect of such events. This report may be combined with that required under the Central Valley Water Board Standard Provision contained in section VI.A.2.i of this Order.

The technical report shall:

- i. Identify the possible sources of spills, leaks, untreated waste by-pass, and contaminated drainage. Loading and storage areas, power outage, waste treatment unit outage, and failure of process equipment, tanks and pipes should be considered.

- ii. Evaluate the effectiveness of present facilities and procedures and state when they became operational.
- iii. Predict the effectiveness of the proposed facilities and procedures and provide an implementation schedule containing interim and final dates when they will be constructed, implemented, or operational.

The Central Valley Water Board, after review of the technical report, may establish conditions which it deems necessary to control accidental discharges and to minimize the effects of such events. Such conditions shall be incorporated as part of this Order, upon notice to the Discharger.

- k. A publicly owned treatment works whose waste flow has been increasing, or is projected to increase, shall estimate when flows will reach hydraulic and treatment capacities of its treatment and disposal facilities. The projections shall be made in January, based on the last 3 years' average dry weather flows, peak wet weather flows and total annual flows, as appropriate. When any projection shows that capacity of any part of the facilities may be exceeded in 4 years, the Discharger shall notify the Central Valley Water Board by 31 January. A copy of the notification shall be sent to appropriate local elected officials, local permitting agencies and the press. Within 120 days of the notification, the Discharger shall submit a technical report showing how it will prevent flow volumes from exceeding capacity or how it will increase capacity to handle the larger flows. The Central Valley Water Board may extend the time for submitting the report.
- l. The Discharger shall submit technical reports as directed by the Executive Officer. All technical reports required herein that involve planning, investigation, evaluation, or design, or other work requiring interpretation and proper application of engineering or geologic sciences, shall be prepared by or under the direction of persons registered to practice in California pursuant to California Business and Professions Code, sections 6735, 7835, and 7835.1. To demonstrate compliance with Title 16, CCR, sections 415 and 3065, all technical reports must contain a statement of the qualifications of the responsible registered professional(s). As required by these laws, completed technical reports must bear the signature(s) and seal(s) of the registered professional(s) in a manner such that all work can be clearly attributed to the professional responsible for the work.
- m. The Central Valley Water Board is authorized to enforce the terms of this permit under several provisions of the Water Code, including, but not limited to, sections 13385, 13386, and 13387.
- n. In the event of any change in control or ownership of land or waste discharge facilities presently owned or controlled by the Discharger, the Discharger shall notify the succeeding owner or operator of the existence of this Order by letter, a copy of which shall be immediately forwarded to the Central Valley Water Board.

To assume operation under this Order, the succeeding owner or operator must apply in writing to the Executive Officer requesting transfer of the Order. The request must contain the requesting entity's full legal name, the state of incorporation if a corporation, address and telephone number of the persons responsible for contact with the Central Valley Water Board and a statement. The statement shall comply with the signatory and certification requirements in the federal Standard Provisions (Attachment D, section V.B) and state that the new owner or operator assumes full responsibility for compliance with this Order. Failure to submit the request shall be considered a discharge without requirements, a violation of the Water Code. Transfer shall be approved or disapproved in writing by the Executive Officer.

- o. Failure to comply with provisions or requirements of this Order, or violation of other applicable laws or regulations governing discharges from this Facility, may subject the Discharger to administrative or civil liabilities, criminal penalties, and/or other enforcement remedies to ensure compliance. Additionally, certain violations may subject the Discharger to civil or criminal enforcement from appropriate local, state, or federal law enforcement entities.
- p. In the event the Discharger does not comply or will be unable to comply for any reason, with any prohibition, effluent limitation, or receiving water limitation of this Order, the Discharger shall notify the Central Valley Water Board by telephone (916) 464-3291 within 24 hours of having knowledge of such noncompliance, and shall confirm this notification in writing within five days, unless the Central Valley Water Board waives confirmation. The written notification shall state the nature, time, duration, and cause of noncompliance, and shall describe the measures being taken to remedy the current noncompliance and prevent recurrence including, where applicable, a schedule of implementation. Other noncompliance requires written notification as above at the time of the normal monitoring report.

## **B. Monitoring and Reporting Program Requirements**

The Discharger shall comply with the MRP, and future revisions thereto, in Attachment E.

## **C. Special Provisions**

### **1. Reopener Provisions**

- a. Conditions that necessitate a major modification of a permit are described in 40 CFR section 122.62, including, but not limited to:
  - i. If new or amended applicable water quality standards are promulgated or approved pursuant to section 303 of the CWA, or amendments thereto, this permit may be reopened and modified in accordance with the new or amended standards.

- ii. When new information, that was not available at the time of permit issuance, would have justified different permit conditions at the time of issuance.
- b. **Mercury.** If mercury is found to be causing toxicity based on acute or chronic toxicity test results, or if a TMDL program is adopted, this Order shall be reopened, and the mass effluent limitation modified (higher or lower). If the Central Valley Water Board determines that a mercury offset program is feasible for Dischargers subject to a NPDES permit, then this Order may be reopened to reevaluate the mercury mass loading limitation and the need for a mercury offset program for the Discharger.
- c. **Whole Effluent Toxicity (WET).** As a result of a Toxicity Reduction Evaluation (TRE), this Order may be reopened to include a revised chronic toxicity effluent limitation, a revised acute toxicity effluent limitation, and/or an effluent limitation for a specific toxicant identified in a TRE. Additionally, if the State Water Board revises the SIP's toxicity control provisions, this Order may be reopened to implement the new provisions.
- d. **Ultraviolet (UV) Disinfection Operating Specifications.** The UV operating specifications in this Order are based on UV guidelines developed by the National Water Research Institute and American Water Works Association Research Foundation titled, "Ultraviolet Disinfection Guidelines for Drinking Water and Water Reuse", and the recommendations of the Division of Drinking Water's from results of a spot-check bioassay included with the letter dated 14 June 2019. The Discharger is planning to replace the current UV disinfection system in 2021 because the existing system has reached the end of its useful life. If the Discharger conducts a site-specific UV engineering study on the new UV disinfection system that identifies site-specific UV operating specifications that will achieve the virus inactivation equivalent to Title 22 disinfected tertiary recycled water, this Order may be reopened to modify the UV operating specifications.
- e. **Central Valley Salinity Alternatives for Long-Term Sustainability (CV-SALTS).** On 17 January 2020, certain Basin Plan Amendments to incorporate new strategies for addressing ongoing salt and nitrate accumulation in the Central Valley became effective. Other provisions subject to U.S. EPA approval became effective on 2 November 2020, when approved by U.S. EPA. As the Central Valley Water Board moves forward to implement those provisions that are now in effect, this Order may be amended or modified to incorporate new or modified requirements necessary for implementation of the Basin Plan Amendments. More information regarding these Amendments can be found on the [Central Valley Salinity Alternatives for Long-Term Sustainability \(CV-SALTS\) web page](https://www.waterboards.ca.gov/centralvalley/water_issues/salinity/):  
([https://www.waterboards.ca.gov/centralvalley/water\\_issues/salinity/](https://www.waterboards.ca.gov/centralvalley/water_issues/salinity/))

## 2. Special Studies, Technical Reports and Additional Monitoring Requirements

- a. **Toxicity Reduction Evaluation Requirements.** This Provision requires the Discharger to investigate the causes of, and identify corrective actions to reduce or eliminate, effluent toxicity. If the discharge exceeds the chronic toxicity thresholds defined in this Provision, the Discharger is required to initiate a TRE in accordance with an approved TRE Work Plan and take actions to mitigate the impact of the discharge and prevent recurrence of toxicity. A TRE is a site-specific study conducted in a stepwise process to identify the source(s) of toxicity and the effective control measures for effluent toxicity. TREs are designed to identify the causative agents and sources of whole effluent toxicity, evaluate the effectiveness of the toxicity control options, and confirm the reduction in effluent toxicity. Alternatively, under certain conditions as described in this provision below, the Discharger may participate in an approved Toxicity Evaluation Study (TES) in lieu of conducting a site-specific TRE.
  - i. **Numeric Toxicity Monitoring Trigger.** The numeric Toxicity Unit (TUc) monitoring trigger is 1 TUc (where  $TUc = 100/NOEC$ ). The monitoring trigger is not an effluent limitation; it is the toxicity threshold at which the Discharger is required to initiate additional actions to evaluate effluent toxicity as specified in subsection ii, below.
  - ii. **Chronic Toxicity Monitoring Trigger Exceeded.** When a chronic whole effluent toxicity result during routine monitoring exceeds the chronic toxicity monitoring trigger, the Discharger shall proceed as follows:
    - (a) **Initial Toxicity Check.** If the result is less than or equal to 1.3 TUc (as  $100/EC_{25}$ ) OR the percent effect is less than 25 percent at 100 percent effluent, check for any operation or sample collection issues and return to routine chronic toxicity monitoring. Otherwise, if the result is greater than 1.3 TUc (as  $100/EC_{25}$ ) AND the percent effect is greater than or equal to 25 percent at 100 percent effluent, proceed to subsection (b).
    - (b) **Evaluate 6-week Median.** The Discharger may take two additional samples within 6 weeks of the initial routine sampling event exceeding the chronic toxicity monitoring trigger to evaluate compliance using a 6-week median. If the 6-week median is greater than 1.3 TUc (as  $100/EC_{25}$ ) and the percent effect is greater than 25 percent at 100 percent effluent, proceed with subsection (c). Otherwise, the Discharger shall check for any operation or sample collection issues and return to routine chronic toxicity monitoring. See Compliance Determination Section VII.J for procedures for calculating 6-week median.
    - (c) **Toxicity Source Easily Identified.** If the source(s) of the toxicity is easily identified (e.g., temporary plant upset), the Discharger

shall make necessary corrections to the Facility and shall resume routine chronic toxicity monitoring; If the source of toxicity is not easily identified the Discharger shall conduct a site-specific TRE or participate in an approved TES as described in the following subsections.

- (d) **Toxicity Evaluation Study.** If the percent effect is less than or equal to 50 percent at 100 percent effluent, as the median of up to three consecutive chronic toxicity tests within a 6-week period, the Discharger may participate in an approved TES in lieu of a site-specific TRE. The TES may be conducted individually or as part of a coordinated group effort with other similar dischargers. If the Discharger chooses not to participate in an approved TES, a site-specific TRE shall be initiated in accordance with subsection (e)(i), below. Nevertheless, the Discharger may participate in an approved TES instead of a TRE if the Discharger has conducted a site-specific TRE within the past 12 months and has been unsuccessful in identifying the toxicant.
- (e) **Toxicity Reduction Evaluation.** If the percent effect is greater than 50 percent at 100 percent effluent, as the median of three consecutive chronic toxicity tests within a 6-week period, the Discharger shall initiate a site-specific TRE as follows:
- (i) **Within thirty (30) days** of exceeding the chronic toxicity monitoring trigger, the Discharger shall submit a TRE Action Plan to the Central Valley Water Board including, at minimum:
- Specific actions the Discharger will take to investigate and identify the cause(s) of toxicity, including a TRE WET monitoring schedule;
  - Specific actions the Discharger will take to mitigate the impact of the discharge and prevent the recurrence of toxicity; and
  - A schedule for these actions.

### 3. Best Management Practices and Pollution Prevention

- a. **Salinity Evaluation and Minimization Plan.** The Discharger shall continue to implement a salinity evaluation and minimization plan to identify and address sources of salinity discharged from the Facility.

The Discharger shall evaluate the effectiveness of the salinity evaluation and minimization plan and provide a summary with the Report of Waste Discharge.



#### 4. Construction, Operation and Maintenance Specifications

- a. **Filtration System Operating Specifications.** To ensure the filtration system is operating properly to provide adequate disinfection of the wastewater, the turbidity of the filter effluent measured at Monitoring Location UVS-001 shall not exceed:
  - i. 2 NTU as a daily average;
  - ii. 5 NTU more than 5 percent of the time within a 24-hour period; and
  - iii. 10 NTU, at any time.
- b. **Ultraviolet (UV) Disinfection System Operating Specifications.** The UV disinfection system must be operated in accordance with the Discharger's Title 22 Engineering Report, approved by the State Water Resources Control Board, Division of Drinking Water in a letter dated 14 June 2019, which includes an operations and maintenance program that assures adequate disinfection to provide virus inactivation equivalent to Title 22 Disinfected Tertiary Recycled Water. The following UV disinfection operating specifications will be evaluated to determine compliance with this requirement:
  - i. **UV Dose.** The minimum hourly average UV dose in the UV reactor shall be 127 millijoules per square centimeter ( $\text{mJ}/\text{cm}^2$ ).
  - ii. **UV Transmittance.** The minimum hourly average UV transmittance (at 254 nanometers) in the wastewater measured at UVS-001 shall not fall below 28 percent.
  - iii. The lamp sleeves and cleaning system components must be visually inspected per the manufacturer's operations manual for physical wear (scoring, solarization, seal leaks, cleaning fluid levels, etc.) and to check the efficacy of the cleaning system.
  - iv. The lamp sleeves must be cleaned periodically as necessary to meet the UV dose requirements.
  - v. Lamps must be replaced per the manufacturer's operations manual, or sooner, if there are indications the lamps are failing to provide adequate disinfection. Lamp age and lamp replacement records must be maintained.
- c. **Solids Stabilization Basins Operating Requirements.**
  - i. The treatment facilities, which include two solids stabilization basins that may also provide temporary emergency storage, shall be designed, constructed, operated, and maintained to prevent inundation or washout due to floods with a 100-year return frequency.
  - ii. Public contact with wastewater shall be precluded through such means as fences, signs, and other acceptable alternatives.

- iii. Ponds shall be managed to prevent breeding of mosquitoes. In particular,
  - (a) An erosion control program should assure that small coves and irregularities are not created around the perimeter of the water surface.
  - (b) Weeds shall be minimized.
  - (c) Dead algae, vegetation, and debris shall not accumulate on the water surface.
- iv. Freeboard in the emergency storage pond shall never be less than 2 feet (measured vertically to the lowest point of overflow), except if lesser freeboard does not threaten the integrity of the pond, no overflow of the pond occurs, and lesser freeboard is due to direct precipitation or storm water runoff occurring as a result of annual precipitation with greater than a 100-year recurrence interval, or a storm event with an intensity greater than a 25-year, 24-hour storm event.
- v. Ponds shall have sufficient capacity to accommodate allowable wastewater flow and design seasonal precipitation and ancillary inflow and infiltration during the non-irrigation season. Design seasonal precipitation shall be based on total annual precipitation using a return period of 100 years, distributed monthly in accordance with historical rainfall patterns. Freeboard shall never be less than 2 feet (measured vertically to the lowest point of overflow).
- vi. Prior to the onset of the rainy season of each year, available pond storage capacity shall at least equal the volume necessary to comply with section VI.C.4.c.v, above.
- vii. Objectionable odors originating at this Facility shall not be perceivable beyond the limits of the wastewater treatment plant.

## 5. Special Provisions for Publicly-Owned Treatment Works (POTWs)

- a. **Sludge/Biosolids Treatment.** Sludge in this document means the solid, semisolid, and liquid residues removed during primary, secondary, or advanced wastewater treatment processes. Solid waste refers to grit and screening material generated during preliminary treatment. Residual sludge means sludge that will not be subject to further treatment at the wastewater treatment plant. Biosolids refer to sludge that has been treated and tested and shown to be capable of being beneficially and legally used pursuant to federal and state regulations as a soil amendment for agricultural, silvicultural, horticultural, and land reclamation activities as specified under 40 C.F.R. Part 503.

- i. Collected screenings, residual sludge, biosolids, and other solids removed from liquid wastes shall be disposed of in a manner approved by the Executive Officer, and consistent with Consolidated Regulations for Treatment, Storage, Processing, or Disposal of Solid Waste, as set forth in Title 27, CCR, division 2, subdivision 1, section 20005, et seq. Removal for further treatment, storage, disposal, or reuse at sites (e.g., landfill, composting sites, soil amendment sites) that are operated in accordance with valid waste discharge requirements issued by a Regional Water Board will satisfy these specifications.

Sludge and solid waste shall be removed from screens, sumps, ponds, clarifiers, etc. as needed to ensure optimal plant performance.

The treatment of sludge generated at the Facility shall be confined to the Facility property and conducted in a manner that precludes infiltration of waste constituents into soils in a mass or concentration that will violate groundwater limitations in section V.B. of this Order. In addition, the storage of residual sludge, solid waste, and biosolids on Facility property shall be temporary and controlled, and contained in a manner that minimizes leachate formation and precludes infiltration of waste constituents into soils in a mass or concentration that will violate groundwater limitations included in section V.B. of this Order.

- ii. The use, disposal, storage, and transportation of biosolids shall comply with existing federal and state laws and regulations, including permitting requirements and technical standards included in 40 C.F.R. Part 503. If the State Water Board and the Central Valley Water Board are given the authority to implement regulations contained in 40 C.F.R. Part 503, this Order may be reopened to incorporate appropriate time schedules and technical standards. The Discharger must comply with the standards and time schedules contained in 40 C.F.R. Part 503 whether or not they have been incorporated into this Order.
  - iii. The Discharger shall comply with section IX.A. Biosolids of the MRP, Attachment E.
  - iv. The onsite sludge/biosolids treatment, processing, and storage for the Facility is described in the Fact Sheet (Attachment F, section II.A). Any proposed change in the onsite treatment, processing, or storage of sludge/biosolids shall be reported to the Executive Officer at least 90 days in advance of the change and shall not be implemented until written approval by the Executive Officer.
- b. **Resource Recovery from Anaerobically Digestible Material.** If the Discharger will receive hauled-in anaerobically digestible material for injection into an anaerobic digester, the Discharger shall notify the Central Valley Water Board and develop and implement Standard Operating Procedures for this activity. The Standard Operating Procedures shall be developed prior to receiving hauled-in anaerobically digestible material.

The Standard Operating Procedures shall address material handling, including unloading, screening, or other processing prior to anaerobic digestion; transportation; spill prevention; and spill response. In addition, the Standard Operating Procedures shall address avoidance of the introduction of materials that could cause interference, pass-through, or upset of the treatment processes; avoidance of prohibited material; vector control; odor control; operation and maintenance; and the disposition of any solid waste segregated from introduction to the digester. The Discharger shall train its staff on the Standard Operating Procedures and shall maintain records for a minimum of five years for each load received, describing the hauler, waste type, and quantity received. In addition, the Discharger shall maintain records for a minimum of five years for the disposition, location, and quantity of cumulative pre-digestion-segregated solid waste hauled off-site.

## 6. Other Special Provisions

- a. **Title 22, or Equivalent, Disinfection Requirements.** Wastewater shall be oxidized, coagulated, filtered, and adequately disinfected pursuant to the State Water Board, Division of Drinking Water reclamation criteria, CCR, Title 22, division 4, chapter 3, (Title 22), or equivalent.

## 7. Compliance Schedules

- a. **Compliance Schedules for Final Effluent Limitation for Chronic Whole Effluent Toxicity.** This Order requires compliance with the final effluent limitations for chronic WET specified in section IV.A.1.e of this Order by **1 April 2028**. The Discharger shall comply with the time schedule shown in the Technical Reports Table E-12 to ensure compliance with the final effluent limitation.

## VII. COMPLIANCE DETERMINATION

- A. **BOD<sub>5</sub> and TSS Effluent Limitations (section IV.A.1.a).** Compliance with the final effluent limitations for BOD<sub>5</sub> and TSS required in Waste Discharge Requirements section IV.A.1.a shall be ascertained by 24-hour composite samples. Compliance with effluent limitations required in Waste Discharge Requirements section IV.A.1.c for percent removal shall be calculated using the arithmetic mean of BOD<sub>5</sub> and TSS in effluent samples collected over a monthly period as a percentage of the arithmetic mean of the values for influent samples collected at approximately the same times during the same period.
- B. **Total Mercury Mass Loading Effluent Limitation (section IV.A.1.g).** The procedures for calculating mass loadings are as follows:
  1. The total pollutant mass load for each calendar year shall be determined using average of all concentration data collected that year and the corresponding average flow during that year. All effluent monitoring data collected under the MRP, pretreatment program, and any special studies shall be used for these

calculations. The calendar year total mass loading shall be the calculated average mass loading for the individual calendar year.

2. In calculating compliance, the Discharger shall count all non-detect measures at one-half of the detection level. If compliance with the effluent limitation is not attained due to the non-detect contribution, the Discharger shall improve and implement available analytical capabilities and compliance shall be evaluated with consideration of the detection limits.
- C. Average Dry Weather Flow Discharge Prohibition (section III.E).** The average dry weather discharge flow represents the daily average flow when groundwater is at or near normal and runoff is not occurring. Compliance with the average dry weather flow discharge prohibition will be determined annually based on the average daily flow over three consecutive dry weather months (e.g., July, August, and September).
- D. Total Coliform Organisms Effluent Limitations (section IV.A.1.f).** For each day that an effluent sample is collected and analyzed for total coliform organisms, the 7-day median shall be determined by calculating the median concentration of total coliform bacteria in the effluent utilizing the bacteriological results of the last 7 days. For example, if a sample is collected on a Wednesday, the result from that sampling event and all results from the previous 6 days (i.e., Tuesday, Monday, Sunday, Saturday, Friday, and Thursday) are used to calculate the 7-day median. If the 7-day median of total coliform organisms exceeds a most probable number (MPN) of 2.2 per 100 milliliters, the Discharger will be considered out of compliance.
- E. Electrical Conductivity Effluent Limitation (section IV.A.1.h).** Compliance with the calendar year average annual effluent limitation for electrical conductivity shall be determined by calculating the sum of monthly samples measured during a calendar year divided by the number of monthly samples measured during that year.
- F. Mass Effluent Limitations.** The mass effluent limitations contained in the Final Effluent Limitations IV.A.1.a are based on the permitted average dry weather flow and calculated as follows:
- $$\text{Mass (lbs/day)} = \text{Flow (MGD)} \times \text{Concentration (mg/L)} \times 8.34 \text{ (conversion factor)}$$
- If the effluent flow exceeds the permitted average dry weather flow during wet-weather seasons, the effluent mass limitations contained in Final Effluent Limitations IV.A.1.a shall not apply.
- G. Priority Pollutant Effluent Limitations.** Compliance with effluent limitations for priority pollutants shall be determined in accordance with section 2.4.5 of the SIP, as follows:
1. Dischargers shall be deemed out of compliance with an effluent limitation, if the concentration of the priority pollutant in the monitoring sample is greater than the effluent limitation and greater than or equal to the reporting level (RL).

2. Dischargers shall be required to conduct a Pollutant Minimization Program (PMP) in accordance with section 2.4.5.1 of the SIP when there is evidence that the priority pollutant is present in the effluent above an effluent limitation and either:
  - a. sample result is reported as detected, but not quantified (DNQ) and the effluent limitation is less than the RL; or
  - b. sample result is reported as non-detect (ND) and the effluent limitation is less than the method detection limit (MDL).
3. When determining compliance with an AMEL and more than one sample result is available in a month, the discharger shall compute the arithmetic mean unless the data set contains one or more reported determinations of DNQ or ND. In those cases, the discharger shall compute the median in place of the arithmetic mean in accordance with the following procedure:
  - a. The data set shall be ranked from low to high, reported ND determinations lowest, DNQ determinations next, followed by quantified values (if any). The order of the individual ND or DNQ determinations is unimportant.
  - b. The median value of the data set shall be determined. If the data set has an odd number of data points, then the median is the middle value. If the data set has an even number of data points, then the median is the average of the two values around the middle unless one or both of the points are ND or DNQ, in which case the median value shall be the lower of the two data points where DNQ is lower than a value and ND is lower than DNQ.
4. If a sample result, or the arithmetic mean or median of multiple sample results, is below the RL, and there is evidence that the priority pollutant is present in the effluent above an effluent limitation and the discharger conducts a PMP (as described in section 2.4.5.1), the discharger shall **not** be deemed out of compliance.

**H. Dissolved Oxygen Receiving Water Limitations (section V.A.4).** The Facility provides a high level of treatment including tertiary filtration and nitrification, which results in minimal dissolved oxygen impacts in the receiving water. Monthly receiving water monitoring is required in the MRP (Attachment E) and is sufficient to evaluate the impacts of the discharge and compliance with this Order. Monthly receiving water monitoring data, measured at monitoring locations RSW-U and RSW-D, will be used to determine compliance with part “c” of the dissolved oxygen receiving water limitation to ensure the discharge does not cause the dissolved oxygen concentrations in the South Fork of Putah Creek to be reduced below 7.0 mg/L at any time. However, should more frequent dissolved oxygen and temperature receiving water monitoring be conducted, Central Valley Water Board staff may evaluate compliance with parts “a” and “b”.

- I. **Temperature Receiving Water Limitation (section V.A.14).** Compliance with the temperature receiving water limitation shall be determined based on the difference in temperature at Monitoring Locations RSW-U and RSW-D.
- J. **Chronic Whole Effluent Toxicity Effluent Limitation (section IV.A.1.e and IV.A.2.a).** To evaluate compliance with the chronic whole effluent toxicity effluent limitations, the median TUC shall be the median of up to three consecutive chronic toxicity bioassays during a six-week period. This includes a routine chronic toxicity monitoring event and two subsequent optional compliance monitoring events. If additional compliance monitoring events are not conducted, the median is equal to the result for the routine chronic toxicity monitoring event. If only one additional compliance monitoring event is conducted, the median will be established as the arithmetic mean of the routine monitoring event and compliance monitoring event.

In determining compliance with the final effluent limitation in sections IV.A.1.e (**effective 1 April 2028**), where the median chronic toxicity units exceed 1 TUC (as 100/NOEC), the Discharger will be deemed out of compliance with the final chronic toxicity effluent limitation if the median chronic toxicity units for any endpoint also exceed a reporting level of 1.3 TUC (as 100/EC25) AND the percent effect at 100 percent effluent exceeds 25 percent. The percent effect used to evaluate compliance with the final chronic toxicity effluent limitation shall be based on the chronic toxicity bioassay result(s) from the sample(s) used to establish the median TUC result, as described in the paragraph above. If the median TUC is based on two equal chronic toxicity bioassay results, the percent effect of the sample with the greatest percent effect shall be used to evaluate compliance with the final chronic toxicity effluent limitation.

In determining compliance with the interim effluent limitation in section IV.A.2.a (**effective immediately through 31 March 2028**), where the median chronic toxicity units exceed **16 TUC** (as 100/NOEC) for any endpoint, the Discharger will be deemed out of compliance with the interim chronic toxicity effluent limitation if the median chronic toxicity units for any endpoint also exceed a reporting level of 16 TUC (as 100/EC25) AND the percent effect at 6.25 percent effluent for the same endpoint also exceeds 25 percent. The percent effect used to evaluate compliance with the interim chronic toxicity effluent limitation shall be based on the chronic toxicity bioassay result(s) from the sample(s) used to establish the median TUC result, as described above. If the median TUC is based on two equal chronic toxicity bioassay results, the percent effect of the sample with the greatest percent effect shall be used to evaluate compliance with the interim chronic toxicity effluent limitation.

## ATTACHMENT A – DEFINITIONS

### 1Q10

The lowest one-day flow with an average reoccurrence frequency of once in ten years.

### 7Q10

The lowest average seven consecutive day flow with an average reoccurrence frequency of once in ten years

### Arithmetic Mean ( $\mu$ )

Also called the average, is the sum of measured values divided by the number of samples. For ambient water concentrations, the arithmetic mean is calculated as follows:

$$\text{Arithmetic mean} = \mu = \Sigma x / n$$

where:  $\Sigma x$  is the sum of the measured ambient water concentrations, and n is the number of samples.

### Average Annual Effluent Limitation (AAEL)

The highest allowable average of daily discharges over a calendar year, calculated as the sum of all daily discharges measured during a calendar year divided by the number of daily discharges measured during that year.

### Average Monthly Effluent Limitation (AMEL)

The highest allowable average of daily discharges over a calendar month, calculated as the sum of all daily discharges measured during a calendar month divided by the number of daily discharges measured during that month.

### Average Weekly Effluent Limitation (AWEL)

The highest allowable average of daily discharges over a calendar week (Sunday through Saturday), calculated as the sum of all daily discharges measured during a calendar week divided by the number of daily discharges measured during that week.

### Bioaccumulative

Those substances taken up by an organism from its surrounding medium through gill membranes, epithelial tissue, or from food and subsequently concentrated and retained in the body of the organism.

### Carcinogenic

Pollutants are substances that are known to cause cancer in living organisms.

### Coefficient of Variation (CV)

CV is a measure of the data variability and is calculated as the estimated standard deviation divided by the arithmetic mean of the observed values.

### Daily Discharge

Daily Discharge is defined as either: (1) the total mass of the constituent discharged over the calendar day (12:00 am through 11:59 pm) or any 24-hour period that reasonably represents a



calendar day for purposes of sampling (as specified in the permit), for a constituent with limitations expressed in units of mass or; (2) the unweighted arithmetic mean measurement of the constituent over the day for a constituent with limitations expressed in other units of measurement (e.g., concentration).

The daily discharge may be determined by the analytical results of a composite sample taken over the course of one day (a calendar day or other 24-hour period defined as a day) or by the arithmetic mean of analytical results from one or more grab samples taken over the course of the day.

For composite sampling, if 1 day is defined as a 24-hour period other than a calendar day, the analytical result for the 24-hour period will be considered as the result for the calendar day in which the 24-hour period ends.

#### **Detected, but Not Quantified (DNQ)**

DNQ are those sample results less than the RL, but greater than or equal to the laboratory's MDL. Sample results reported as DNQ are estimated concentrations.

#### **Dilution Credit**

Dilution Credit is the amount of dilution granted to a discharge in the calculation of a water quality-based effluent limitation, based on the allowance of a specified mixing zone. It is calculated from the dilution ratio or determined through conducting a mixing zone study or modeling of the discharge and receiving water.

#### **Effect Concentration (EC)**

A point estimate of the toxicant concentration that would cause an observable adverse effect (e.g. death, immobilization, or serious incapacitation) in a given percent of the test organisms, calculated from a continuous model (e.g. Probit Model). EC<sub>25</sub> is a point estimate of the toxicant concentration that would cause an observable adverse effect in 25 percent of the test organisms.

#### **Effluent Concentration Allowance (ECA)**

ECA is a value derived from the water quality criterion/objective, dilution credit, and ambient background concentration that is used, in conjunction with the coefficient of variation for the effluent monitoring data, to calculate a long-term average (LTA) discharge concentration. The ECA has the same meaning as waste load allocation (WLA) as used in U.S. EPA guidance (Technical Support Document For Water Quality-based Toxics Control, March 1991, second printing, EPA/505/2-90-001).

#### **Enclosed Bays**

Enclosed Bays means indentations along the coast that enclose an area of oceanic water within distinct headlands or harbor works. Enclosed bays include all bays where the narrowest distance between the headlands or outermost harbor works is less than 75 percent of the greatest dimension of the enclosed portion of the bay. Enclosed bays include, but are not limited to, Humboldt Bay, Bodega Harbor, Tomales Bay, Drake's Estero, San Francisco Bay, Morro Bay, Los Angeles-Long Beach Harbor, Upper and Lower Newport Bay, Mission Bay, and San Diego Bay. Enclosed bays do not include inland surface waters or ocean waters.

### **Endpoint**

An effect that is measured in a toxicity study. Endpoints in toxicity tests may include, but are not limited to survival, reproduction, and growth.

### **Estimated Chemical Concentration**

The estimated chemical concentration that results from the confirmed detection of the substance by the analytical method below the ML value.

### **Estuaries**

Estuaries means waters, including coastal lagoons, located at the mouths of streams that serve as areas of mixing for fresh and ocean waters. Coastal lagoons and mouths of streams that are temporarily separated from the ocean by sandbars shall be considered estuaries. Estuarine waters shall be considered to extend from a bay or the open ocean to a point upstream where there is no significant mixing of fresh water and seawater. Estuarine waters included, but are not limited to, the Sacramento-San Joaquin Delta, as defined in Water Code section 12220, Suisun Bay, Carquinez Strait downstream to the Carquinez Bridge, and appropriate areas of the Smith, Mad, Eel, Noyo, Russian, Klamath, San Diego, and Otay rivers. Estuaries do not include inland surface waters or ocean waters.

### **Inhibition Concentration**

Inhibition Concentration (IC) is a point estimate of the toxicant concentration that would cause a given percent reduction in a non-lethal biological measurement (e.g., reproduction or growth), calculated from a continuous model (i.e., Interpolation Method). IC25 is a point estimate of the toxic concentration that would cause a 25-percent reduction in a non-lethal biological measurement.

### **Inland Surface Waters**

All surface waters of the state that do not include the ocean, enclosed bays, or estuaries.

### **Instantaneous Maximum Effluent Limitation**

The highest allowable value for any single grab sample or aliquot (i.e., each grab sample or aliquot is independently compared to the instantaneous maximum limitation).

### **Instantaneous Minimum Effluent Limitation**

The lowest allowable value for any single grab sample or aliquot (i.e., each grab sample or aliquot is independently compared to the instantaneous minimum limitation).

### **Maximum Daily Effluent Limitation (MDEL)**

The highest allowable daily discharge of a pollutant, over a calendar day (or 24-hour period). For pollutants with limitations expressed in units of mass, the daily discharge is calculated as the total mass of the pollutant discharged over the day. For pollutants with limitations expressed in other units of measurement, the daily discharge is calculated as the arithmetic mean measurement of the pollutant over the day.

### **Median**

The middle measurement in a set of data. The median of a set of data is found by first arranging the measurements in order of magnitude (either increasing or decreasing order). If

the number of measurements (n) is odd, then the median =  $X_{(n+1)/2}$ . If n is even, then the median =  $(X_{n/2} + X_{(n/2)+1})/2$  (i.e., the midpoint between the n/2 and n/2+1).

**Method Detection Limit (MDL)**

MDL is the minimum measured concentration of a substance that can be reported with 99 percent confidence that the measured concentration is distinguishable from method blank results, as defined in in 40 C.F.R. Part 136, Attachment B.

**Minimum Level (ML)**

ML is the concentration at which the entire analytical system must give a recognizable signal and acceptable calibration point. The ML is the concentration in a sample that is equivalent to the concentration of the lowest calibration standard analyzed by a specific analytical procedure, assuming that all the method specified sample weights, volumes, and processing steps have been followed.

**Mixing Zone**

Mixing Zone is a limited volume of receiving water that is allocated for mixing with a wastewater discharge where water quality criteria can be exceeded without causing adverse effects to the overall water body.

**No-Observed-Effect-Concentration (NOEC)**

The highest concentration of toxicant to which organisms are exposed in a full life-cycle or partial life-cycle (short-term) test, that causes no observable adverse effects on the test organisms (i.e., the highest concentration of toxicant in which the values for the observed responses are not statistically significantly different from the controls).

**Not Detected (ND)**

Sample results which are less than the laboratory's MDL.

**Ocean Waters**

The territorial marine waters of the State as defined by California law to the extent these waters are outside of enclosed bays, estuaries, and coastal lagoons. Discharges to ocean waters are regulated in accordance with the State Water Board's California Ocean Plan.

**Percent Effect**

The percent effect at the instream waste concentration (IWC) shall be calculated using untransformed data and the following equation:

$$\text{Percent Effect of the Sample} = \frac{\text{Mean Control Response} - \text{Mean Sample Response}}{\text{Mean Control Response}} \cdot 100$$

**Persistent Pollutants**

Persistent pollutants are substances for which degradation or decomposition in the environment is nonexistent or very slow.

**Pollutant Minimization Program (PMP)**

PMP means waste minimization and pollution prevention actions that include, but are not limited to, product substitution, waste stream recycling, alternative waste management methods, and education of the public and businesses. The goal of the PMP shall be to reduce all potential sources of a priority pollutant(s) through pollutant minimization (control) strategies, including pollution prevention measures as appropriate, to maintain the effluent concentration at or below the water quality-based effluent limitation. Pollution prevention measures may be particularly appropriate for persistent bioaccumulative priority pollutants where there is evidence that beneficial uses are being impacted. The Central Valley Water Board may consider cost effectiveness when establishing the requirements of a PMP. The completion and implementation of a Pollution Prevention Plan, if required pursuant to Water Code section 13263.3(d), shall be considered to fulfill the PMP requirements.

**Pollution Prevention**

Pollution Prevention means any action that causes a net reduction in the use or generation of a hazardous substance or other pollutant that is discharged into water and includes, but is not limited to, input change, operational improvement, production process change, and product reformulation (as defined in Water Code section 13263.3). Pollution prevention does not include actions that merely shift a pollutant in wastewater from one environmental medium to another environmental medium, unless clear environmental benefits of such an approach are identified to the satisfaction of the State Water Resources Control Board (State Water Board) or Central Valley Water Board.

**Satellite Collection System**

The portion, if any, of a sanitary sewer system owned or operated by a different public agency than the agency that owns and operates the wastewater treatment facility that a sanitary sewer system is tributary to.

**Source of Drinking Water**

Any water designated as municipal or domestic supply (MUN) in a Central Valley Water Board Basin Plan.

**Standard Deviation ( $\sigma$ )**

Standard Deviation is a measure of variability that is calculated as follows:

$$\sigma = (\sum [(x - \mu)^2] / (n - 1))^{0.5}$$

where:

- x is the observed value;
- $\mu$  is the arithmetic mean of the observed values; and
- n is the number of samples.

**Toxicity Reduction Evaluation (TRE)**

TRE is a study conducted in a stepwise process designed to identify the causative agents of effluent or ambient toxicity, isolate the sources of toxicity, evaluate the effectiveness of toxicity control options, and then confirm the reduction in toxicity. The first steps of the TRE consist of

the collection of data relevant to the toxicity, including additional toxicity testing, and an evaluation of facility operations and maintenance practices, and best management practices. A Toxicity Identification Evaluation (TIE) may be required as part of the TRE, if appropriate. (A TIE is a set of procedures to identify the specific chemical(s) responsible for toxicity. These procedures are performed in three phases (characterization, identification, and confirmation) using aquatic organism toxicity tests.)

ATTACHMENT B – MAP

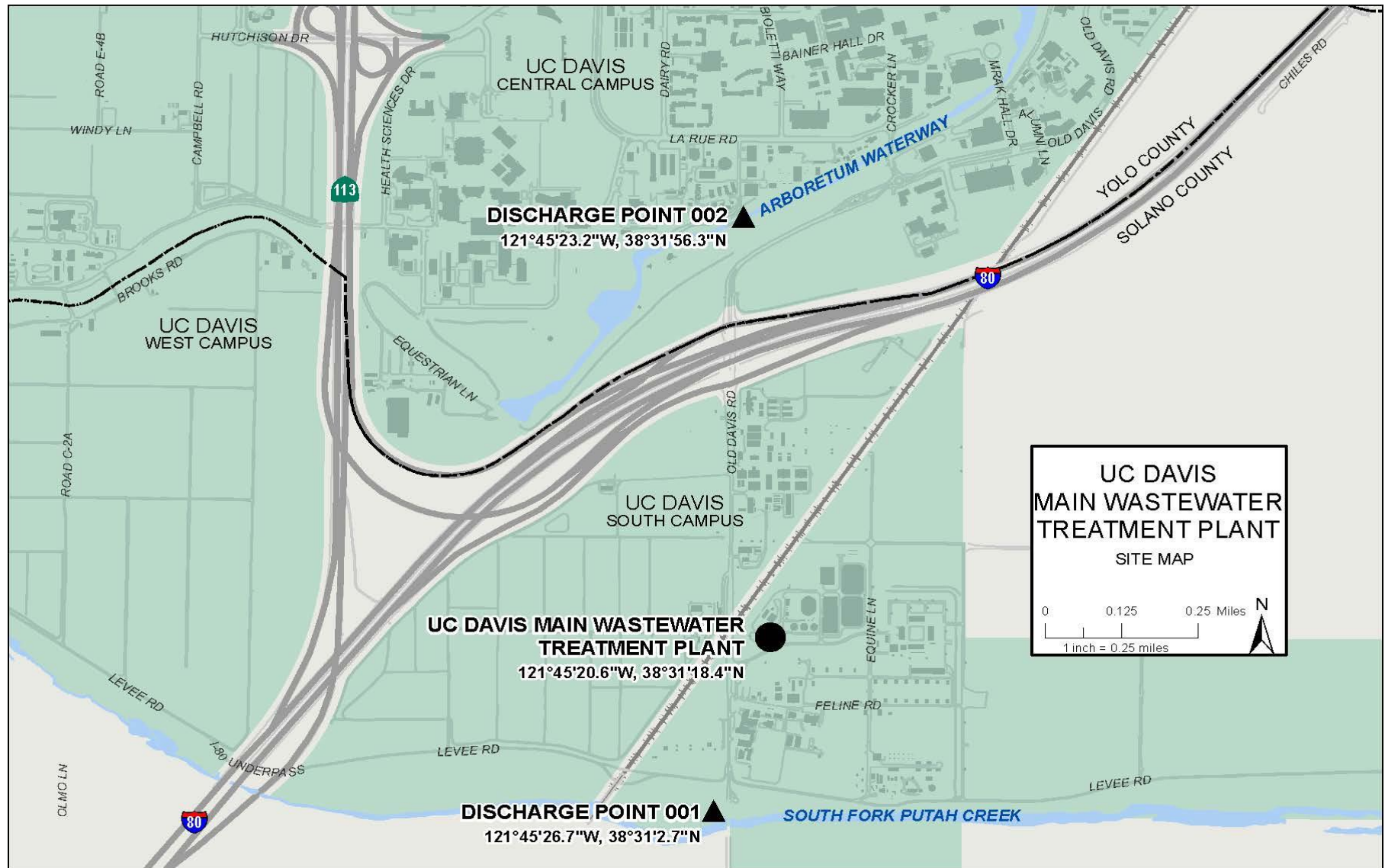

ATTACHMENT C – FLOW SCHEMATIC

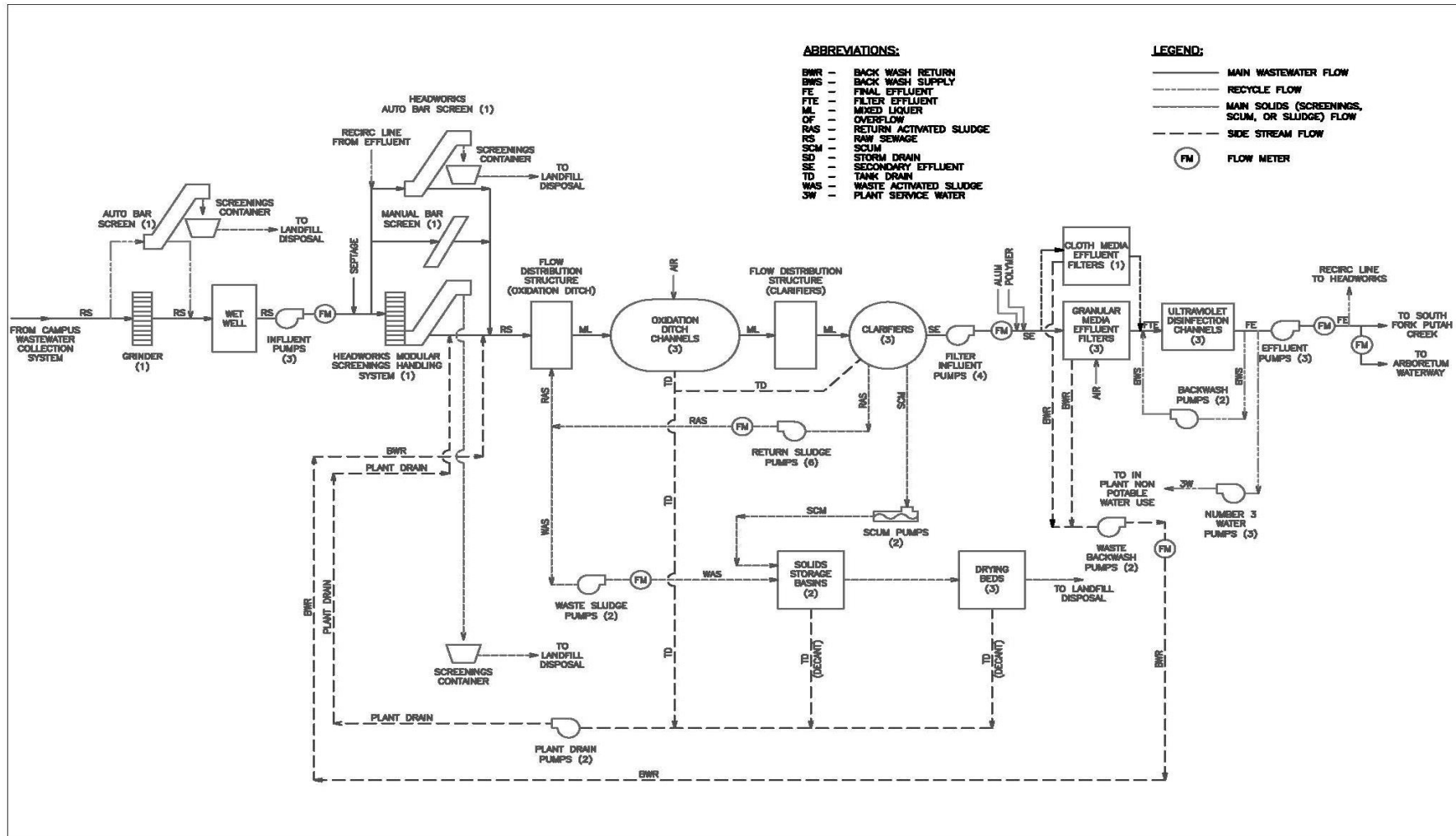

University of California, Davis  
Wastewater Treatment Plant

Wastewater Flow Schematic

## ATTACHMENT D – STANDARD PROVISIONS

### I. STANDARD PROVISIONS – PERMIT COMPLIANCE

#### A. Duty to Comply:

1. The Discharger must comply with all of the terms, requirements, and conditions of this Order. Any noncompliance constitutes a violation of the Clean Water Act (CWA) and the California Water Code and is grounds for enforcement action; permit termination, revocation and reissuance, or modification; denial of a permit renewal application; or a combination thereof. (40 C.F.R. section 122.41(a); Wat. Code, sections 13261, 13263, 13265, 13268, 13000, 13001, 13304, 13350, 13385.)
2. The Discharger shall comply with effluent standards or prohibitions established under Section 307(a) of the CWA for toxic pollutants within the time provided in the regulations that establish these standards or prohibitions, even if this Order has not yet been modified to incorporate the requirement. (40 C.F.R. section 122.41(a)(1).)

#### B. Need to Halt or Reduce Activity Not a Defense

It shall not be a defense for a Discharger in an enforcement action that it would have been necessary to halt or reduce the permitted activity in order to maintain compliance with the conditions of this Order. (40 C.F.R. section 122.41(c).)

#### C. Duty to Mitigate

The Discharger shall take all reasonable steps to minimize or prevent any discharge in violation of this Order that has a reasonable likelihood of adversely affecting human health or the environment. (40 C.F.R. section 122.41(d).)

#### D. Proper Operation and Maintenance

The Discharger shall at all times properly operate and maintain all facilities and systems of treatment and control (and related appurtenances) which are installed or used by the Discharger to achieve compliance with the conditions of this Order. Proper operation and maintenance also includes having adequate laboratory controls and appropriate quality assurance procedures. This provision requires the operation of backup or auxiliary facilities or similar systems that are installed by a Discharger only when necessary to achieve compliance with the conditions of this Order. (40 C.F.R. section 122.41(e).)

#### E. Property Rights

1. This Order does not convey any property rights of any sort or any exclusive privileges. (40 C.F.R. section 122.41(g).)



2. The issuance of this Order does not authorize any injury to persons or property or invasion of other private rights, or any infringement of state or local law or regulations. (40 C.F.R. section 122.5(c).)

**F. Inspection and Entry**

The Discharger shall allow the Central Valley Water Board, State Water Board, U.S. EPA, and/or their authorized representatives (including an authorized contractor acting as their representative), upon the presentation of credentials and other documents, as may be required by law, to (33 U.S.C. section 1318(a)(4)(B); 40 C.F.R. section 122.41(i); Wat. Code, section 13267, 13383):

1. Enter upon the Discharger's premises where a regulated facility or activity is located or conducted, or where records are kept under the conditions of this Order (33 U.S.C section 1318(a)(4)(B)(ii); 40 C.F.R. section 122.41(i)(1); Wat. Code, sections 13267, 13383);
2. Have access to and copy, at reasonable times, any records that must be kept under the conditions of this Order (33 U.S.C. section 1318(a)(4)(B)(ii); 40 C.F.R. section 122.41(i)(2); Wat. Code, sections 13267, 13383);
3. Inspect and photograph, at reasonable times, any facilities, equipment (including monitoring and control equipment), practices, or operations regulated or required under this Order (33 U.S.C section 1318(a)(4)(B)(ii); 40 C.F.R. section 122.41(i)(3); Wat. Code, section 13267, 13383); and
4. Sample or monitor, at reasonable times, for the purposes of assuring Order compliance or as otherwise authorized by the CWA or the Water Code, any substances or parameters at any location. (33 U.S.C section 1318(a)(4)(B); 40 C.F.R. section 122.41(i)(4); Wat. Code, sections 13267, 13383.)

**G. Bypass**

1. Definitions
  - a. "Bypass" means the intentional diversion of waste streams from any portion of a treatment facility. (40 C.F.R. section 122.41(m)(1)(i).)
  - b. "Severe property damage" means substantial physical damage to property, damage to the treatment facilities, which causes them to become inoperable, or substantial and permanent loss of natural resources that can reasonably be expected to occur in the absence of a bypass. Severe property damage does not mean economic loss caused by delays in production. (40 C.F.R. section 122.41(m)(1)(ii).)
2. Bypass not exceeding limitations. The Discharger may allow any bypass to occur which does not cause exceedances of effluent limitations, but only if it is for essential maintenance to assure efficient operation. These bypasses are not

subject to the provisions listed in Standard Provisions – Permit Compliance I.G.3, I.G.4, and I.G.5 below. (40 C.F.R. section 122.41(m)(2).)

3. Prohibition of bypass. Bypass is prohibited, and the Central Valley Water Board may take enforcement action against a Discharger for bypass, unless (40 C.F.R. section 122.41(m)(4)(i)):
  - a. Bypass was unavoidable to prevent loss of life, personal injury, or severe property damage (40 C.F.R. section 122.41(m)(4)(i)(A));
  - b. There were no feasible alternatives to the bypass, such as the use of auxiliary treatment facilities, retention of untreated wastes, or maintenance during normal periods of equipment downtime. This condition is not satisfied if adequate back-up equipment should have been installed in the exercise of reasonable engineering judgment to prevent a bypass that occurred during normal periods of equipment downtime or preventive maintenance (40 C.F.R. section 122.41(m)(4)(i)(B)); and
  - c. The Discharger submitted notice to the Central Valley Water Board as required under Standard Provisions – Permit Compliance I.G.5 below. (40 C.F.R. section 122.41(m)(4)(i)(C).)
4. The Central Valley Water Board may approve an anticipated bypass, after considering its adverse effects, if the Central Valley Water Board determines that it will meet the three conditions listed in Standard Provisions – Permit Compliance I.G.3 above. (40 C.F.R. section 122.41(m)(4)(ii).)
5. **Notice**
  - a. **Anticipated bypass.** If the Discharger knows in advance of the need for a bypass, it shall submit prior notice if possible, at least 10 days before the date of the bypass. The notice shall be sent to the Central Valley Water Board. As of 21 December 2023, all notices shall be submitted electronically to the initial recipient (State Water Board’s [California Integrated Water Quality System \(CIWQS\) Program website](http://www.waterboards.ca.gov/water_issues/programs/ciwqs/) ([http://www.waterboards.ca.gov/water\\_issues/programs/ciwqs/](http://www.waterboards.ca.gov/water_issues/programs/ciwqs/)), defined in Standard Provisions – Reporting V.J below. Notices shall comply with 40 C.F.R. Part 3, section 122.22, and 40 C.F.R. Part 127. (40 C.F.R. section 122.41(m)(3)(i).)
  - b. **Unanticipated bypass.** The Discharger shall submit a notice of an unanticipated bypass as required in Standard Provisions - Reporting V.E below (24-hour notice). The notice shall be sent to the Central Valley Water Board. As of 21 December 2023, all notices shall be submitted electronically to the initial recipient (State Water Board’s [California Integrated Water Quality System \(CIWQS\) Program website](http://www.waterboards.ca.gov/water_issues/programs/ciwqs/) ([http://www.waterboards.ca.gov/water\\_issues/programs/ciwqs/](http://www.waterboards.ca.gov/water_issues/programs/ciwqs/)), defined in Standard Provisions – Reporting V.J below. Notices shall comply with 40

C.F.R. Part 3, section 122.22, and 40 C.F.R. Part 127. (40 C.F.R. section 122.41(m)(3)(ii).)

## H. Upset

Upset means an exceptional incident in which there is unintentional and temporary noncompliance with technology-based permit effluent limitations because of factors beyond the reasonable control of the Discharger. An upset does not include noncompliance to the extent caused by operational error, improperly designed treatment facilities, inadequate treatment facilities, lack of preventive maintenance, or careless or improper operation. (40 C.F.R. section 122.41(n)(1).)

1. Effect of an upset. An upset constitutes an affirmative defense to an action brought for noncompliance with such technology-based permit effluent limitations if the requirements of Standard Provisions – Permit Compliance I.H.2 below are met. No determination made during administrative review of claims that noncompliance was caused by upset, and before an action for noncompliance, is final administrative action subject to judicial review. (40 C.F.R. section 122.41(n)(2).)
2. Conditions necessary for a demonstration of upset. A Discharger who wishes to establish the affirmative defense of upset shall demonstrate, thorough properly signed, contemporaneous operating logs or other relevant evidence that (40 C.F.R. section 122.41(n)(3)):
  - a. An upset occurred and that the Discharger can identify the cause(s) of the upset (40 C.F.R. section 122.41(n)(3)(i));
  - b. The permitted facility was, at the time, being properly operated (40 C.F.R. section 122.41(n)(3)(ii));
  - c. The Discharger submitted notice of the upset as required in Standard Provisions – Reporting V.E.2.b below (24-hour notice) (40 C.F.R. section 122.41(n)(3)(iii)); and
  - d. The Discharger complied with any remedial measures required under Standard Provisions – Permit Compliance I.C above. (40 C.F.R. section 122.41(n)(3)(iv).)
3. Burden of proof. In any enforcement proceeding, the Discharger seeking to establish the occurrence of an upset has the burden of proof. (40 C.F.R. section 122.41(n)(4).)

## II. STANDARD PROVISIONS – PERMIT ACTION

### A. General

This Order may be modified, revoked and reissued, or terminated for cause. The filing of a request by the Discharger for modification, revocation and reissuance, or termination, or a notification of planned changes or anticipated noncompliance does not stay any Order condition. (40 C.F.R. section 122.41(f).)

**B. Duty to Reapply**

If the Discharger wishes to continue an activity regulated by this Order after the expiration date of this Order, the Discharger must apply for and obtain a new permit. (40 C.F.R. section 122.41(b).)

**C. Transfers**

This Order is not transferable to any person except after notice to the Central Valley Water Board. The Central Valley Water Board may require modification or revocation and reissuance of the Order to change the name of the Discharger and incorporate such other requirements as may be necessary under the CWA and the Water Code. (40 C.F.R. section 122.41(l)(3); 122.61.)

**III. STANDARD PROVISIONS – MONITORING**

- A.** Samples and measurements taken for the purpose of monitoring shall be representative of the monitored activity. (40 C.F.R. section 122.41(j)(1).)
- B.** Monitoring must be conducted according to test procedures approved under 40 C.F.R. Part 136 for the analyses of pollutants unless another method is required under 40 C.F.R. subchapters N or O. Monitoring must be conducted according to sufficiently sensitive test methods approved under 40 C.F.R. Part 136 for the analysis of pollutants or pollutant parameters or as required under 40 C.F.R. chapter 1, subchapter N or O. For the purposes of this paragraph, a method is sufficiently sensitive when the method has the lowest ML of the analytical methods approved under 40 C.F.R. Part 136 or required under 40 C.F.R. chapter 1, subchapter N or O for the measured pollutant or pollutant parameter, or when:

- 1. The method minimum level (ML) is at or below the level of the most stringent effluent limitation established in the permit for the measured pollutant or pollutant parameter, and:
  - a. The method ML is at or below the level of the most stringent applicable water quality criterion for the measured pollutant or pollutant parameter, or;
  - b. The method ML is above the applicable water quality criterion but the amount of the pollutant or pollutant parameter in the facility's discharge is high enough that the method detects and quantifies the level of the pollutant or pollutant parameter in the discharge;

In the case of pollutants or pollutant parameters for which there are no approved methods under 40 C.F.R. Part 136 or otherwise required under 40 C.F.R. chapter 1, subchapters N or O, monitoring must be conducted according to a test procedure specified in this Order for such pollutants or pollutant parameters. (40 C.F.R. sections 122.21(e)(3), 122.41(j)(4); 122.44(i)(1)(iv).)

#### **IV. STANDARD PROVISIONS – RECORDS**

- A.** Except for records of monitoring information required by this Order related to the Discharger's sewage sludge use and disposal activities, which shall be retained for a period of at least five years (or longer as required by 40 C.F.R. part 503), the Discharger shall retain records of all monitoring information, including all calibration and maintenance records and all original strip chart recordings for continuous monitoring instrumentation, copies of all reports required by this Order, and records of all data used to complete the application for this Order, for a period of at least three (3) years from the date of the sample, measurement, report or application. This period may be extended by request of the Central Valley Water Board Executive Officer at any time. (40 C.F.R. section 122.41(j)(2).)
- B.** Records of monitoring information shall include:
1. The date, exact place, and time of sampling or measurements (40 C.F.R. section 122.41(j)(3)(i));
  2. The individual(s) who performed the sampling or measurements (40 C.F.R. section 122.41(j)(3)(ii));
  3. The date(s) analyses were performed (40 C.F.R. section 122.41(j)(3)(iii));
  4. The individual(s) who performed the analyses (40 C.F.R. section 122.41(j)(3)(iv));
  5. The analytical techniques or methods used (40 C.F.R. section 122.41(j)(3)(v)); and
  6. The results of such analyses. (40 C.F.R. section 122.41(j)(3)(vi).)
- C.** Claims of confidentiality for the following information will be denied (40 C.F.R. section 122.7(b)):
1. The name and address of any permit applicant or Discharger (40 C.F.R. section 122.7(b)(1)); and
  2. Permit applications and attachments, permits and effluent data. (40 C.F.R. section 122.7(b)(2).)

#### **V. STANDARD PROVISIONS – REPORTING**

##### **A. Duty to Provide Information**

The Discharger shall furnish to the Central Valley Water Board, State Water Board, or U.S. EPA within a reasonable time, any information which the Central Valley Water Board, State Water Board, or U.S. EPA may request to determine whether cause exists for modifying, revoking and reissuing, or terminating this Order or to determine compliance with this Order. Upon request, the Discharger shall also

furnish to the Central Valley Water Board, State Water Board, or U.S. EPA copies of records required to be kept by this Order. (40 C.F.R. section 122.41(h); Wat. Code, sections 13267, 13383.)

**B. Signatory and Certification Requirements**

1. All applications, reports, or information submitted to the Central Valley Water Board, State Water Board, and/or U.S. EPA shall be signed and certified in accordance with Standard Provisions – Reporting V.B.2, V.B.3, V.B.4, V.B.5, and V.B.6 below. (40 C.F.R. section 122.41(k).)
2. All permit applications shall be signed by either a principal executive officer or ranking elected official. For purposes of this provision, a principal executive officer of a federal agency includes: (i) the chief executive officer of the agency, or (ii) a senior executive officer having responsibility for the overall operations of a principal geographic unit of the agency (e.g., Regional Administrators of U.S. EPA). (40 C.F.R. section 122.22(a)(3).)
3. All reports required by this Order and other information requested by the Central Valley Water Board, State Water Board, or U.S. EPA shall be signed by a person described in Standard Provisions – Reporting V.B.2 above, or by a duly authorized representative of that person. A person is a duly authorized representative only if:
  - a. The authorization is made in writing by a person described in Standard Provisions – Reporting V.B.2 above (40 C.F.R. section 122.22(b)(1));
  - b. The authorization specifies either an individual or a position having responsibility for the overall operation of the regulated facility or activity such as the position of plant manager, operator of a well or a well field, superintendent, position of equivalent responsibility, or an individual or position having overall responsibility for environmental matters for the company. (A duly authorized representative may thus be either a named individual or any individual occupying a named position.) (40 C.F.R. section 122.22(b)(2)); and
  - c. The written authorization is submitted to the Central Valley Water Board and State Water Board. (40 C.F.R. section 122.22(b)(3).)
4. If an authorization under Standard Provisions – Reporting V.B.3 above is no longer accurate because a different individual or position has responsibility for the overall operation of the facility, a new authorization satisfying the requirements of Standard Provisions – Reporting V.B.3 above must be submitted to the Central Valley Water Board and State Water Board prior to or together with any reports, information, or applications, to be signed by an authorized representative. (40 C.F.R. section 122.22(c).)
5. Any person signing a document under Standard Provisions – Reporting V.B.2 or V.B.3 above shall make the following certification:

“I certify under penalty of law that this document and all attachments were prepared under my direction or supervision in accordance with a system designed to assure that qualified personnel properly gather and evaluate the information submitted. Based on my inquiry of the person or persons who manage the system or those persons directly responsible for gathering the information, the information submitted is, to the best of my knowledge and belief, true, accurate, and complete. I am aware that there are significant penalties for submitting false information, including the possibility of fine and imprisonment for knowing violations.” (40 C.F.R. section 122.22(d).)

6. Any person providing the electronic signature for such documents described in Standard Provision – V.B.1, V.B.2, or V.B.3 that are submitted electronically shall meet all relevant requirements of Standard Provisions – Reporting V.B, and shall ensure that all of the relevant requirements of 40 C.F.R. part 3 (Cross-Media Electronic Reporting) and 40 C.F.R. part 127 (NPDES Electronic Reporting Requirements) are met for that submission. (40 C.F.R section 122.22(e).)

### **C. Monitoring Reports**

1. Monitoring results shall be reported at the intervals specified in the Monitoring and Reporting Program (Attachment E) in this Order. (40 C.F.R. section 122.41(l)(4).)
2. Monitoring results must be reported on a Discharge Monitoring Report (DMR) form or forms provided or specified by the Central Valley Water Board or State Water Board for reporting the results of monitoring, sludge use, or disposal practices. As of 21 December 2016, all reports and forms must be submitted electronically to the initial recipient, defined in Standard Provisions – Reporting V.J, and comply with 40 C.F.R. part 3, section 122.22, and 40 C.F.R. part 127. (40 C.F.R. section 122.41(l)(4)(i).)
3. If the Discharger monitors any pollutant more frequently than required by this Order using test procedures approved under 40 C.F.R. part 136, or another method required for an industry-specific waste stream under 40 C.F.R. subchapters N or O, the results of such monitoring shall be included in the calculation and reporting of the data submitted in the DMR or sludge reporting form specified by the Central Valley Water Board. (40 C.F.R. section 122.41(l)(4)(ii).)
4. Calculations for all limitations, which require averaging of measurements, shall utilize an arithmetic mean unless otherwise specified in this Order. (40 C.F.R. section 122.41(l)(4)(iii).)

**D. Compliance Schedules**

Reports of compliance or noncompliance with, or any progress reports on, interim and final requirements contained in any compliance schedule of this Order, shall be submitted no later than 14 days following each schedule date. (40 C.F.R. section 122.41(l)(5).)

**E. Twenty-Four Hour Reporting**

1. The Discharger shall report any noncompliance which may endanger health or the environment. Any information shall be provided orally within 24 hours from the time the Discharger becomes aware of the circumstances. A report shall also be provided within five (5) days of the time the Discharger becomes aware of the circumstances. The report shall contain a description of the noncompliance and its cause; the period of noncompliance, including exact dates and times, and if the noncompliance has not been corrected, the anticipated time it is expected to continue; and steps taken or planned to reduce, eliminate, and prevent reoccurrence of the noncompliance.

For noncompliance events related to combined sewer overflows, sanitary sewer overflows, or bypass events, these reports must include the data described above (with the exception of time of discovery) as well as the type of event (combined sewer overflows, sanitary sewer overflows, or bypass events), type of sewer overflow structure (e.g., manhole, combined sewer overflow outfall), discharge volumes untreated by the treatment works treating domestic sewage, types of human health and environmental impacts of the sewer overflow event, and whether the noncompliance was related to wet weather.

As of 21 December 2020 all reports related to combined sewer overflows, sanitary sewer overflows, or bypass events must be submitted electronically to the initial recipient (State Water Board) defined in Standard Provisions – Reporting V.J. The reports shall comply with 40 C.F.R. part 3. They may also require the Discharger to electronically submit reports not related to combined sewer overflows, sanitary sewer overflows, or bypass events under this section. (40 C.F.R. section 122.41(l)(6)(i).)

**F. Planned Changes**

The Discharger shall give notice to the Central Valley Water Board as soon as possible of any planned physical alterations or additions to the permitted facility. Notice is required under this provision only when (40 C.F.R. section 122.41(l)(1)):

1. The alteration or addition to a permitted facility may meet one of the criteria for determining whether a facility is a new source in section 122.29(b) (40 C.F.R. section 122.41(l)(1)(i)); or
2. The alteration or addition could significantly change the nature or increase the quantity of pollutants discharged. This notification applies to pollutants that are



subject neither to effluent limitations in this Order nor to notification requirements under section 122.42(a)(1) (see Additional Provisions— Notification Levels VII.A.1). (40 C.F.R. section 122.41(l)(1)(ii).)

3. The alteration or addition results in a significant change in the Discharger's sludge use or disposal practices, and such alteration, addition, or change may justify the application of permit conditions that are different from or absent in the existing permit, including notification of additional use or disposal sites not reported during the permit application process or not reported pursuant to an approved land application plan. (40 C.F.R. section 122.41(l)(1)(iii).)

**G. Anticipated Noncompliance**

The Discharger shall give advance notice to the Central Valley Water Board of any planned changes in the permitted facility or activity that may result in noncompliance with this Order's requirements. (40 C.F.R. section 122.41(l)(2).)

**H. Other Noncompliance**

The Discharger shall report all instances of noncompliance not reported under Standard Provisions – Reporting V.C, V.D, and V.E above at the time monitoring reports are submitted. The reports shall contain the information listed in Standard Provision – Reporting V.E above. For noncompliance events related to combined sewer overflows, sanitary sewer overflows, or bypass events, these reports shall contain the information described in Standard Provision – Reporting V.E and the applicable required data in appendix A to 40 C.F.R. part 127. The Central Valley Water Board may also require the Discharger to electronically submit reports not related to combined sewer overflows, sanitary sewer overflows, or bypass events under this section. (40 C.F.R. section 122.41(l)(7).)

**I. Other Information**

When the Discharger becomes aware that it failed to submit any relevant facts in a permit application, or submitted incorrect information in a permit application or in any report to the Central Valley Water Board, State Water Board, or U.S. EPA, the Discharger shall promptly submit such facts or information. (40 C.F.R. section 122.41(l)(8).)

**J. Initial Recipient for Electronic Reporting Data**

The owner, operator, or the duly authorized representative is required to electronically submit NPDES information specified in appendix A to 40 C.F.R. part 127 to the appropriate initial recipient, as determined by U.S. EPA, and as defined in 40 C.F.R. section 127.2(b). U.S. EPA will identify and publish the list of initial recipients on its website and in the Federal Register, by state and by NPDES data group [see 40 C.F.R. section 127.2(c)]. U.S. EPA will update and maintain this listing. (40 C.F.R. section 122.41(l)(9).)

## **VI. STANDARD PROVISIONS – ENFORCEMENT**

- A.** The Central Valley Water Board is authorized to enforce the terms of this permit under several provisions of the Water Code, including, but not limited to, sections 13385, 13386, and 13387.

## **VII. ADDITIONAL PROVISIONS – NOTIFICATION LEVELS**

### **A. Publicly-Owned Treatment Works (POTWs)**

All POTWs shall provide adequate notice to the Central Valley Water Board of the following (40 C.F.R. section 122.42(b)):

1. Any new introduction of pollutants into the POTW from an indirect discharger that would be subject to sections 301 or 306 of the CWA if it were directly discharging those pollutants (40 C.F.R. section 122.42(b)(1)); and
2. Any substantial change in the volume or character of pollutants being introduced into that POTW by a source introducing pollutants into the POTW at the time of adoption of the Order. (40 C.F.R. section 122.42(b)(2).)
3. Adequate notice shall include information on the quality and quantity of effluent introduced into the POTW as well as any anticipated impact of the change on the quantity or quality of effluent to be discharged from the POTW. (40 C.F.R. section 122.42(b)(3).)

**ATTACHMENT E – MONITORING AND REPORTING PROGRAM**

**Table of Contents**

I.	General Monitoring Provisions.....	2
II.	Monitoring Locations .....	3
III.	Influent Monitoring Requirements.....	4
	A. Monitoring Location INF-001.....	4
IV.	Effluent Monitoring Requirements .....	5
	A. Monitoring Location EFF-001.....	5
V.	Whole Effluent Toxicity (WET) Testing Requirements.....	7
VI.	Land Discharge Monitoring Requirements – Not Applicable .....	11
VII.	Recycling Monitoring Requirements – not applicable.....	11
VIII.	Receiving Water Monitoring Requirements .....	11
	A. Monitoring Locations RSW-U and RSW-D.....	11
IX.	Other Monitoring Requirements.....	12
	A. Biosolids – Not Applicable .....	12
	B. Municipal Water Supply .....	12
	C. Filtration System and UV Disinfection System.....	13
	D. Pyrethroid Pesticides Monitoring .....	14
	E. Effluent and Receiving Water Characterization .....	17
X.	Reporting Requirements.....	24
	A. General Monitoring and Reporting Requirements.....	24
	B. Self-Monitoring Reports (SMRs) .....	25
	C. Discharge Monitoring Reports (DMR’s) .....	28
	D. Other Reports .....	29

**Tables**

Table E-1.	Monitoring Station Locations.....	4
Table E-2.	Influent Monitoring.....	5
Table E-3.	Effluent Monitoring .....	5
Table E-4.	Chronic Toxicity Testing Dilution Series.....	9
Table E-5.	Receiving Water Monitoring Requirements.....	11
Table E-6.	Municipal Water Supply Monitoring Requirements.....	12
Table E-7.	Filtration System and UV Disinfection System Monitoring Requirements .....	13
Table E-8.	Pyrethroid Pesticides Monitoring.....	14
Table E-9.	Pyrethroid Pesticide Partition Coefficients .....	16
Table E-10.	Effluent and Receiving Water Characterization Monitoring .....	18
Table E-11.	Monitoring Periods and Reporting Schedule .....	25
Table E-12.	Technical Reports .....	30

## **ATTACHMENT E – MONITORING AND REPORTING PROGRAM (MRP)**

The Code of Federal Regulations (40 C.F.R. section 122.48) requires that all NPDES permits specify monitoring and reporting requirements. Water Code sections 13267 and 13383 also authorize the Central Valley Water Board to require technical and monitoring reports. This MRP establishes monitoring and reporting requirements that implement federal and California regulations.

### **I. GENERAL MONITORING PROVISIONS**

- A.** Samples and measurements taken as required herein shall be representative of the volume and nature of the monitored discharge. All samples shall be taken at the monitoring locations specified below and, unless otherwise specified, before the monitored flow joins or is diluted by any other waste stream, body of water, or substance. Monitoring locations shall not be changed without notification to and the approval of the Central Valley Water Board.
- B.** Final effluent samples shall be taken downstream of the last addition of wastes to the treatment or discharge works where a representative sample may be obtained prior to mixing with the receiving waters. Samples shall be collected at such a point and in such a manner to ensure a representative sample of the discharge.
- C.** Chemical, bacteriological, and bioassay analyses of any material required by this Order shall be conducted by a laboratory accredited for such analyses by the State Water Resources Control Board (State Water Board), Division of Drinking Water, in accordance with the provision of Water Code section 13176. Laboratories that perform sample analyses must be identified in all monitoring reports submitted to the Central Valley Water Board. Data generated from field measurements such as pH, dissolved oxygen (DO), electrical conductivity (EC), turbidity, temperature, and residual chlorine, are exempt pursuant to Water Code Section 13176. A manual containing the steps followed in this program for any field measurements such as pH, DO, EC, turbidity, temperature, and residual chlorine must be kept onsite in the treatment facility laboratory and shall be available for inspection by Central Valley Water Board staff. The Discharger must demonstrate sufficient capability (qualified and trained employees, properly calibrated and maintained field instruments, etc.) to adequately perform these field measurements. The Quality Assurance-Quality Control Program must conform to U.S. EPA guidelines or to procedures approved by the Central Valley Water Board.
- D.** Appropriate flow measurement devices and methods consistent with accepted scientific practices shall be selected and used to ensure the accuracy and reliability of measurements of the volume of monitored discharges. All monitoring instruments and devices used by the Discharger to fulfill the prescribed monitoring program shall be properly maintained and calibrated as necessary, at least yearly, to ensure their continued accuracy. All flow measurement devices shall be calibrated at least once per year to ensure continued accuracy of the devices.

- E. Monitoring results, including noncompliance, shall be reported at intervals and in a manner specified in this MRP.
- F. Laboratory analytical methods shall be sufficiently sensitive in accordance with the Sufficiently Sensitive Methods Rule (SSM Rule) specified under 40 C.F.R. 122.21(e)(3) and 122.44(i)(1)(iv). A U.S. EPA-approved analytical method is sufficiently sensitive for a pollutant/parameter where:
  - 1. The method minimum level (ML) is at or below the applicable water quality objective for the receiving water, or;
  - 2. The method ML is above the applicable water quality objective for the receiving water but the amount of the pollutant/parameter in the discharge is high enough that the method detects and quantifies the level of the pollutant/parameter, or;
  - 3. the method ML is above the applicable water quality objective for the receiving water, but the ML is the lowest of the 40 C.F.R. 136 U.S. EPA-approved analytical methods for the pollutant/parameter.
- G. The Discharger shall ensure that the results of the Discharge Monitoring Report-Quality Assurance (DMR-QA) Study or the most recent Water Pollution Performance Evaluation Study are submitted annually to the State Water Resources Control Board at the following address:

State Water Resources Control Board  
Quality Assurance Program Officer  
Office of Information Management and Analysis  
1001 I Street, Sacramento, CA 95814
- H. The Discharger shall file with the Central Valley Water Board technical reports on self-monitoring performed according to the detailed specifications contained in this MRP.
- I. The results of all monitoring required by this Order shall be reported to the Central Valley Water Board, and shall be submitted in such a format as to allow direct comparison with the limitations and requirements of this Order. Unless otherwise specified, discharge flows shall be reported in terms of the monthly average and the daily maximum discharge flows.

## II. MONITORING LOCATIONS

The Discharger shall establish the following monitoring locations to demonstrate compliance with the effluent limitations, discharge specifications, and other requirements in this Order:

**Table E-1. Monitoring Station Locations**

<b>Discharge Point Name</b>	<b>Monitoring Location Name</b>	<b>Monitoring Location Description</b>
--	INF-001	A location where a representative sample of the influent into the Facility can be collected prior to entering the treatment process. Latitude: 38° 31' 21.0" N - Longitude: 121° 45' 20.5" W
001	EFF-001	A location where a representative sample of the effluent from the Facility can be collected after all treatment processes prior to discharge into the South Fork of Putah Creek. Latitude: 38° 31' 22.2" N - Longitude: 121° 45' 21.6" W
002	EFF-001	A location where a representative sample of the effluent from the Facility can be collected after all treatment processes prior to discharge into the Arboretum Waterway. Latitude: 38° 31' 22.2" N - Longitude: 121° 45' 21.6" W
--	RSW-U	In the South Fork of Putah Creek, approximately 800 feet upstream of the confluence with the Arboretum Waterway. Latitude: 38° 31' 2.4" N - Longitude: 121° 46' 0.7" W
--	RSW-D	In the South Fork of Putah Creek, approximately 200 feet downstream of Discharge Point 001. Latitude: 38° 31' 1.6" N - Longitude: 121° 45' 23.5" W
--	BIO-001	A location where a representative sample of the biosolids can be obtained.
--	UVS-001	A location where a representative sample of wastewater can be collected immediately upstream of the ultraviolet light (UV) disinfection system.
--	UVS-002	A location where a representative sample of the wastewater can be collected immediately downstream of the UV disinfection system.
--	SPL-001	A location where a representative sample of the municipal supply water can be obtained.

The North latitude and West longitude information in Table E-1 are approximate for administrative purposes.

**III. INFLUENT MONITORING REQUIREMENTS**

**A. Monitoring Location INF-001**

1. The Discharger shall monitor influent to the Facility at Monitoring Location INF-001 in accordance with Table E-2 and the testing requirements described in section III.A.2 below:

**Table E-2. Influent Monitoring**

Parameter	Units	Sample Type	Minimum Sampling Frequency
Flow	MGD	Meter	Continuous
Biochemical Oxygen Demand, 5-day @ 20°Celsius	mg/L	24-hour Composite	2/Week
Total Suspended Solids	mg/L	24-hour Composite	2/Week
Electrical Conductivity @ 25°Celsius	µmhos/cm	Grab	1/Quarter

2. **Table E-2 Testing Requirements.** The Discharger shall comply with the following testing requirements when monitoring for the parameters described in Table E-2:
  - a. **Applicable to all parameters except flow.** Parameters shall be analyzed using the analytical methods described in 40 CFR part 136; or by methods approved by the Central Valley Water Board or the State Water Board. In addition, if requested by the Discharger, the sample type may be modified by the Executive Officer to another 40 CFR part 136 allowed sample type.
  - b. All grab samples shall not be collected at the same time each day to get a complete representation of variations in the influent.
  - c. All composite samples shall be collected from a 24-hour flow proportional composite.

**IV. EFFLUENT MONITORING REQUIREMENTS**

**A. Monitoring Location EFF-001**

1. The Discharger shall monitor tertiary treated effluent at Monitoring Location EFF-001 in accordance with Table E-3 and the testing requirements described in section IV.A.2 below:

**Table E-3. Effluent Monitoring**

Parameter	Units	Sample Type	Minimum Sampling Frequency
Flow	MGD	Meter	Continuous
Biochemical Oxygen Demand, 5-day @ 20°Celsius (BOD <sub>5</sub> )	mg/L	24-hour Composite	2/Week
Biochemical Oxygen Demand, 5-day @ 20°Celsius	percent removal	Calculate	1/Month
Total Suspended Solids (TSS)	mg/L	24-hour Composite	2/Week

Parameter	Units	Sample Type	Minimum Sampling Frequency
Total Suspended Solids	percent removal	Calculate	1/Month
pH	standard units	Grab	1/Day
Ammonia Nitrogen, Total (as N)	mg/L	Grab	1/Week
Ammonia Nitrogen, Total (as N)	lbs/day	Grab	1/Week
Dissolved Oxygen	mg/L	Grab	1/Month
Electrical Conductivity @ 25°Celsius	µmhos/cm	Grab	1/Month
Hardness, Total (as CaCO3)	mg/L	Grab	1/Month
Dissolved Organic Carbon (DOC)	mg/L	Grab	1/Quarter
Mercury, Total	µg/L	Grab	1/Year
Nitrate Nitrogen, Total (as N)	mg/L	Grab	1/Month
Nitrite Nitrogen, Total (as N)	mg/L	Grab	1/Month
Nitrate Plus Nitrite (as N)	mg/L	Calculate	1/Month
Temperature	°F	Grab	1/Day

2. **Table E-3 Testing Requirements.** The Discharger shall comply with the following testing requirements when monitoring for the parameters described in Table E-3:
  - a. **Applicable to all parameters (except flow).** Parameters shall be analyzed using the analytical methods described in 40 CFR part 136 or by methods approved by the Central Valley Water Board or the State Water Board. In addition, if requested by the Discharger, the sample type may be modified by the Executive Officer to another 40 CFR part 136 allowed sample type.
  - b. **24-hour composite samples** shall be collected from a 24-hour flow proportional composite.
  - c. A hand-held field meter may be used for **temperature, electrical conductivity, dissolved oxygen, and pH**, provided the meter utilizes a U.S. EPA-approved algorithm/method and is calibrated and maintained in accordance with the manufacturer's instructions. A calibration and maintenance log for each meter used for monitoring required by this MRP shall be maintained at the Facility.
  - d. **Temperature** and **pH** shall be recorded at the time of **ammonia** sample collection.
  - e. **Ammonia Nitrogen** samples shall be collected concurrently with whole effluent toxicity monitoring.
  - f. **Nitrate and Nitrite Nitrogen** monitoring shall be conducted concurrently with hardness sampling.



- g. **Dissolved Organic Carbon.** Hardness, total (as CaCO<sub>3</sub>) and pH samples shall be taken concurrent with dissolved organic carbon samples.
- h. **Total Mercury and Methyl Mercury.** Unfiltered methyl mercury and total mercury samples shall be taken using **clean hands/dirty hands procedures**, as described in U.S. EPA method 1669: Sampling Ambient Water for Trace Metals at EPA Water Quality Criteria Levels, for collection of equipment blanks (section 9.4.4.2). The analysis of methyl mercury and total mercury shall be by U.S. EPA method 1630 and 1631 (Revision E), respectively, with a **reporting limit of 0.05 ng/L for methyl mercury and 0.5 ng/L for total mercury.**
- i. **Temperature, pH, Hardness, Dissolved Oxygen, and Dissolved Organic Carbon.** The effluent samples for temperature, pH, hardness, dissolved oxygen, and dissolved organic carbon shall be taken approximately the same time and on the same date with the receiving water samples for these parameters.

## V. WHOLE EFFLUENT TOXICITY (WET) TESTING REQUIREMENTS

**A. Acute Toxicity Testing.** The Discharger shall conduct acute toxicity testing to determine whether the effluent is contributing acute toxicity to the receiving water. The Discharger shall meet the acute toxicity testing requirement:

1. **Monitoring Frequency** – The Discharger shall perform **quarterly** acute toxicity testing, concurrent with effluent ammonia sampling.
2. **Sample Types** – The Discharger may use flow-through or static renewal testing. For static renewal testing, the samples shall be flow proportional 24-hour composites and shall be representative of the volume and quality of the discharge. The effluent samples shall be taken at Monitoring Location EFF-001.
3. **Test Species** – Test species shall be **fathead minnows** (*Pimephales promelas*).
4. **Methods** – The acute toxicity testing samples shall be analyzed using EPA-821-R-02-012, Fifth Edition. Temperature, total residual chlorine, and pH shall be recorded at the time of sample collection. No pH adjustment may be made unless approved by the Executive Officer.
5. **Test Failure** – If an acute toxicity test does not meet all test acceptability criteria, as specified in the test method, the Discharger must re-sample and re-test as soon as possible, not to exceed 7 days following notification of test failure.

**B. Chronic Toxicity Testing.** The Discharger shall meet the chronic toxicity testing requirements:

1. **Monitoring Frequency** – The Discharger shall perform routine **quarterly** chronic toxicity testing. If the result of the routine chronic toxicity testing event exhibits toxicity, demonstrated by a result greater than 1.3 TUc (as 100/EC<sub>25</sub>) AND a percent effect greater than 25 percent at 100 percent effluent, the Discharger has the option of conducting two additional compliance monitoring events and perform chronic toxicity testing using the species that exhibited toxicity in order to calculate a median. The optional compliance monitoring events shall occur at least one week apart, and the final monitoring event shall be initiated no later than 6 weeks from the routine monitoring event that exhibited toxicity. See Compliance Determination section VII.J for procedures for calculating 6-week median.
2. **Sample Types** – Effluent samples shall be flow proportional 24-hour composites and shall be representative of the volume and quality of the discharge. The effluent samples shall be taken at Monitoring Location EFF-001. The receiving water control shall be a grab sample obtained from Monitoring Location RSW-U, as identified in this MRP.
3. **Sample Volumes** – Adequate sample volumes shall be collected to provide renewal water to complete the test in the event that the discharge is intermittent.
4. **Test Species** – The testing shall be conducted using the most sensitive species. The Discharger shall conduct chronic toxicity tests with ***Ceriodaphnia dubia***, unless otherwise specified in writing by the Executive Officer.
5. **Methods** – The presence of chronic toxicity shall be estimated as specified in Short-term Methods for Estimating the Chronic Toxicity of Effluents and Receiving Waters to Freshwater Organisms, Fourth Edition, EPA/821-R-02-013, October 2002.
6. **Reference Toxicant** – As required by the SIP, all chronic toxicity tests shall be conducted with concurrent testing with a reference toxicant and shall be reported with the chronic toxicity test results.
7. **Dilutions** – For routine and compliance chronic toxicity monitoring, the chronic toxicity testing shall be performed using the dilution series identified in Table E-4, below. For TRE monitoring, the chronic toxicity testing shall also be performed using the dilution series identified in Table E-4, below, unless an alternative dilution series is detailed in the submitted TRE Action Plan. A receiving water control or laboratory water control may be used as the diluent.

**Table E-4. Chronic Toxicity Testing Dilution Series**

<b>Samples</b>	<b>Dilution%</b>	<b>Dilution%</b>	<b>Dilution%</b>	<b>Dilution%</b>	<b>Dilution%</b>	<b>Dilution%</b>	<b>Controls</b>
% Effluent	100	75	50	25	12.5	6.25	0
% Control Water	0	25	50	75	87.5	93.75	100

8. **Test Failure** – The Discharger must re-sample and re-test as soon as possible, but no later than fourteen (14) days after receiving notification of a test failure. A test failure is defined as follows:
  - a. The reference toxicant test or the effluent test does not meet all test acceptability criteria as specified in the Short-term Methods for Estimating the Chronic Toxicity of Effluents and Receiving Waters to Freshwater Organisms, Fourth Edition, EPA/821-R-02-013, October 2002 (Method Manual), and its subsequent amendments or revisions; or
  - b. The percent minimum significant difference (PMSD) measured for the test exceeds the upper PMSD bound variability criterion in the Method Manual.
  
- C. **WET Testing Notification Requirements.** The Discharger shall notify the Central Valley Water Board within 24-hours after the receipt of test results exceeding the interim chronic WET effluent limitation specified in section IV.A.2.a of the Order, or the chronic toxicity effluent numeric trigger specified in section VI.C.2.a.i of the Order, or an exceedance of the acute toxicity effluent limitation specified in section IV.A.1.d of the Order.
  
- D. **WET Testing Reporting Requirements.** All toxicity test reports shall include the contracting laboratory’s complete report provided to the Discharger and shall be in accordance with the appropriate “Report Preparation and Test Review” sections of the Method Manual. At a minimum, whole effluent toxicity monitoring shall be reported as follows:
  1. **Chronic WET Reporting.** Routing and compliance chronic toxicity monitoring results shall be reported to the Central Valley Water Board with the quarterly self-monitoring report, and shall contain, at minimum:
    - a. The results expressed in TUc, measured as 100/NOEC, and also measured as 100/LC50, 100/EC25, 100/IC25, and 100/IC50, as appropriate;
    - b. The percent effect at the instream waste concentration
    - c. The statistical methods used to calculate endpoints;
    - d. The statistical output page, which includes the calculation of the PMSD;
    - e. The dates of sample collection and initiation of each toxicity test; and
    - f. The results compared to the numeric toxicity monitoring trigger.

Additionally, the quarterly self-monitoring reports shall contain an updated chronology of chronic toxicity test results expressed in TUc, and organized by test species, type of test (survival, growth or reproduction), and monitoring type, i.e., routine, compliance, TES, or TRE monitoring.

2. **Acute WET Reporting.** Acute toxicity test results shall be submitted with the quarterly discharger self-monitoring reports and reported as percent survival.
3. **TRE Reporting.** Reports for TREs shall be submitted in accordance with the schedule contained in the Discharger's approved TRE Workplan, or as amended by the Discharger's TRE Action Plan.
4. **Quality Assurance (QA).** The Discharger must provide the following information for QA purposes:
  - a. Results of the applicable reference toxicant data with the statistical output page giving the species, NOEC, LOEC, type of toxicant, dilution water used, concentrations used, PMSD, and dates tested.
  - b. The reference toxicant control charts for each endpoint, which include summaries of reference toxicant tests performed by the contracting laboratory.
  - c. Any information on deviations or problems encountered and how they were dealt with.
- E. **Most Sensitive Species Screening.** The Discharger shall perform rescreening to re-evaluate the most sensitive species if there is a significant change in the nature of the discharge. If there are no significant changes during the permit term, a rescreening must be performed prior to permit reissuance and results submitted with the Report of Waste Discharge.
  1. **Frequency of Testing for Species Sensitivity Screening.** Species sensitivity screening for chronic toxicity shall include chronic WET testing for two consecutive calendar quarters, at a minimum (see below), using the water flea (*Ceriodaphnia dubia*), fathead minnow (*Pimephales promelas*), and green alga (*Pseudokirchneriella subcapitata*). The tests shall be performed using 100 percent effluent and one control. If the two species sensitivity rescreening events result in no change in the most sensitive species, the Discharger may cease the species sensitive rescreening testing and the most sensitive species will remain unchanged. If the two species sensitivity rescreening events result in a change to the most sensitive species, the Discharger shall continue three-species testing for the subsequent two quarters and determine the most sensitive species using the results of the four quarterly testing events.
  2. **Determination of Most Sensitive Species.** If a single test in the species sensitivity screening testing exceeds 1 TUc (as 100/NOEC), then the species used in that test shall be established as the most sensitive species. If there is more than a single test that exceeds 1 TUc (as 100/NOEC), then of the species exceeding 1 TUc (as 100/NOEC) that exhibits the highest percent effect shall

be established as the most sensitive species. If none of the tests in the species sensitivity screening exceeds 1 TUc (as 100/NOEC), but at least one of the species exhibits a percent effect greater than 25 percent, then the single species that exhibits the highest percent effect shall be established as the most sensitive species. In all other circumstances, the Executive Officer shall have discretion to determine which single species is the most sensitive considering the test results from the species sensitivity screening.

**VI. LAND DISCHARGE MONITORING REQUIREMENTS – NOT APPLICABLE**

**VII. RECYCLING MONITORING REQUIREMENTS – NOT APPLICABLE**

**VIII. RECEIVING WATER MONITORING REQUIREMENTS**

**A. Monitoring Locations RSW-U and RSW-D**

1. The Discharger shall monitor the South Fork of Putah Creek at RSW-U and RSW-D in accordance with Table E-5 and the testing requirements for Table E-5 described in section A.2 below:

**Table E-5. Receiving Water Monitoring Requirements**

Parameter	Units	Sample Type	Minimum Sampling Frequency
pH	standard units	Grab	1/Week
Dissolved Oxygen	mg/L	Grab	1/Month
Electrical Conductivity @ 25°Celsius	µmhos/cm	Grab	1/Month
Hardness, Total (as CaCO3)	mg/L	Grab	1/Month
Temperature	°F	Grab	1/Week
Dissolved Organic Carbon (DOC)	mg/L	Grab	1/Quarter

2. **Table E-5 Testing Requirements.** The Discharger shall comply with the following testing requirements when monitoring for the parameters described in Table E-5 above:
  - a. **Applicable to all parameters.** Parameters shall be analyzed using the analytical methods described in 40 CFR part 136 or by methods approved by the Central Valley Water Board or the State Water Board. In addition, if requested by the Discharger, the sample type may be modified by the Executive Officer to another 40 CFR part 136 allowed sample type.
  - b. **24-hour composite samples** shall be collected from a 24-hour flow proportional composite.
  - c. A hand-held field meter may be used for **temperature, electrical conductivity, dissolved oxygen, and pH**, provided the meter utilizes a U.S. EPA-approved algorithm/method and is calibrated and maintained in

accordance with the manufacturer's instructions. A calibration and maintenance log for each meter used for monitoring required by this MRP shall be maintained at the Facility.

- d. **Temperature and pH** shall be recorded at the time of **effluent ammonia** sample collection.
  - e. **Dissolved Organic Carbon.** Hardness, total (as CaCO<sub>3</sub>) and pH samples shall be taken concurrent with dissolved organic carbon samples.
  - f. **Temperature, pH, Hardness, Dissolved Oxygen, and Dissolved Organic Carbon.** The receiving water samples for temperature, pH, hardness, dissolved oxygen, and dissolved organic carbon shall be taken approximately the same time and on the same date with the effluent samples for these parameters.
3. In conducting the receiving water sampling, a log shall be kept of the receiving water conditions throughout the reach bounded by RSW-U and RSW-D when discharging to the South Fork of Putah Creek. Attention shall be given to the presence of:
- a. Floating or suspended matter;
  - b. Discoloration;
  - c. Bottom deposits;
  - d. Aquatic life;
  - e. Visible films, sheens, or coatings;
  - f. Fungi, slimes, or objectionable growths; and
  - g. Potential nuisance conditions.

Notes on receiving water conditions shall be summarized in the monitoring report.

**IX. OTHER MONITORING REQUIREMENTS**

**A. Biosolids – Not Applicable**

**B. Municipal Water Supply**

- 1. **Monitoring Location SPL-001.** The Discharger shall monitor the municipal water supply at SPL-001 in accordance with Table E-6 and the testing requirements described in section IX.B.2. below.

**Table E-6. Municipal Water Supply Monitoring Requirements**

Parameter	Units	Sample Type	Minimum Sampling
Electrical Conductivity @ 25°Celsius	µmhos/cm	Grab	1/Year

2. **Table E-6 Testing Requirements.** The Discharger shall comply with the following testing requirements when monitoring for the parameters described in Table E-6:
  - a. **Applicable to all parameters.** Electrical conductivity shall be analyzed using the analytical methods described in 40 CFR part 136; or by methods approved by the Central Valley Water Board or the State Water Board. In addition, if requested by the Discharger, the sample type may be modified by the Executive Officer to another 40 CFR part 136 allowed sample type.
  - b. If the water supply is from more than one source, the electrical conductivity shall be reported as a weighted average and include copies of supporting calculations.

**C. Filtration System and UV Disinfection System**

1. **Monitoring Locations UVS-001 and UVS-002.** When discharging to surface water, the Discharger shall monitor the filtration system and the UV disinfection system at Monitoring Locations UVS-001 and UVS-002 in accordance with Table E-7 and the testing requirements described in section IX.C.2 below:

**Table E-7. Filtration System and UV Disinfection System Monitoring Requirements**

Parameter	Units	Sample Type	Monitoring Location	Minimum Sampling Frequency
Flow	MGD	Meter	UVS-001	Continuous
Turbidity	NTU	Meter	UVS-002	Continuous
Number of UV banks in operation	Number	Observation	N/A	Continuous
UV Transmittance	Percent (%)	Meter	UVS-001	Continuous
UV Dose	mJ/cm <sup>2</sup>	Calculated	N/A	Continuous
Total Coliform Organisms	MPN/100mL	Grab	UVS-002	3/Week

2. **Table E-7 Testing Requirements.** The Discharger shall comply with the following testing requirements when monitoring for the parameters described in Table E-7:
  - a. **Applicable to all parameters (except flow).** Parameters shall be analyzed using the analytical methods described in 40 CFR part 136; or by methods approved by the Central Valley Water Board or the State Water Board. In addition, if requested by the Discharger, the sample type may be modified by the Executive Officer to another 40 CFR part 136 allowed sample type.
  - b. **Continuous analyzers.** The Discharger shall report documented routine meter maintenance activities including date, time of day, and duration, in which the analyzer(s) is not in operation. If analyzer(s) fail to provide continuous monitoring for more than two hours and influent and/or effluent

from the disinfection process is not diverted for retreatment, the Discharger shall obtain and report hourly manual and/or grab sample results. The Discharger shall not decrease power settings or reduce the number of UV lamp banks in operation while the continuous analyzers are out of service and water is being disinfected.

- c. **UV Dose.** Report daily minimum hourly average UV dose and daily average UV dose. The minimum hourly average dose shall consist of lowest hourly average dose provided in any channel that had at least one bank of lamps operating during the hour interval. For channels that did not operate for the entire hour interval, the dose will be averaged based on the actual operation time.

**D. Pyrethroid Pesticides Monitoring**

- 1. **Water Column Chemistry Monitoring Requirements.** The Discharger shall conduct effluent and receiving water (South Fork of Putah Creek or the Arboretum Waterway) baseline monitoring in accordance with Table E-8. **Quarterly monitoring shall be conducted for one year** concurrent with the Effluent and Receiving Water Characterization Monitoring (see section IX.E of this MRP for specific dates). The discharger shall also submit a minimum of one quality assurance/quality control (QA/QC) sample during the year to be analyzed for the constituents listed in Table E-8.

The monitoring shall be conducted in the effluent at monitoring location EFF-001 and downstream receiving water at monitoring location RSW-D and the results of such monitoring be submitted to the Central Valley Water Board with the quarterly self-monitoring reports. The Discharger shall use Environmental Laboratory Accreditation Program (ELAP)-accredited laboratories and methods for pyrethroid pesticides water column chemistry monitoring. ELAP-accredited methods are acceptable for pyrethroid chemical analysis provided that the method meets the analytical capability described in Table E-8. A current list of ELAP approved laboratories and points of contact can be found on the [Central Valley Water Board's website](https://www.waterboards.ca.gov/centralvalley/water_issues/tmdl/central_valley_projects/central_valley_pesticides/pyrethroid_tmdl_bpa/index.html) ([https://www.waterboards.ca.gov/centralvalley/water\\_issues/tmdl/central\\_valley\\_projects/central\\_valley\\_pesticides/pyrethroid\\_tmdl\\_bpa/index.html](https://www.waterboards.ca.gov/centralvalley/water_issues/tmdl/central_valley_projects/central_valley_pesticides/pyrethroid_tmdl_bpa/index.html)).

Monitoring can either be conducted by the Discharger or can be done as part of a group monitoring effort. If the Discharger chooses to participate in a group monitoring effort, the timing of the monitoring can be modified by the Executive Officer.

**Table E-8. Pyrethroid Pesticides Monitoring**

Parameter	CAS Number	Sample Units	Sample Type	Analytical Method	Reporting Level
Total Bifenthrin	82657-04-3	ng/L	Grab	To be determined	1.3



Parameter	CAS Number	Sample Units	Sample Type	Analytical Method	Reporting Level
Total Cyfluthrin	68359-37-5	ng/L	Grab	To be determined	1.3
Total Cypermethrin	52315-07-8	ng/L	Grab	To be determined	1.7
Total Esfenvalerate	51630-58-1	ng/L	Grab	To be determined	3.3
Total Lambda-cyhalothrin	91465-08-6	ng/L	Grab	To be determined	1.2
Total Permethrin	52645-53-1	ng/L	Grab	To be determined	10
Freely Dissolved Bifenthrin	82657-04-3	ng/L	Calculated	Calculated from total concentration	--
Freely Dissolved Cyfluthrin	68359-37-5	ng/L	Calculated	Calculated from total concentration	--
Freely Dissolved Cypermethrin	52315-07-8	ng/L	Calculated	Calculated from total concentration	--
Freely Dissolved Esfenvalerate	51630-58-1	ng/L	Calculated	Calculated from total concentration	--
Freely Dissolved Lambda-cyhalothrin	91465-08-6	ng/L	Calculated	Calculated from total concentration	--
Freely Dissolved Permethrin	52645-53-1	ng/L	Calculated	Calculated from total concentration	--
Dissolved Organic Carbon (DOC)	--	mg/L	Grab	--	--
Total Organic Carbon (TOC)	--	mg/L	Grab	--	--

The freely dissolved concentration of each quantified pyrethroid pesticide in a sample may be directly measured or estimated using partition coefficients. Methods for direct measurement must be approved by the Executive Officer before they are used to determine the freely dissolved pyrethroid concentrations that are used for determining exceedances of the pyrethroid pesticides numeric triggers.

To estimate the freely dissolved concentration of a pyrethroid pesticide with partition coefficients, the following equation shall be used:

$$C_{dissolved} = \frac{C_{total}}{1 + (K_{OC} \times [POC]) + (K_{DOC} \times [DOC])}$$

Where:

C dissolved = concentration of a an individual pyrethroid pesticide that is in the freely dissolved phase (ng/L),

C total = total concentration of an individual pyrethroid pesticide in water (ng/L),

KOC = organic carbon-water partition coefficient for the individual pyrethroid pesticide (L/kg),

[POC] = concentration of particulate organic carbon in the water sample (kg/L), which can be calculated as  $[POC]=[TOC]-[DOC]$ ,

[TOC] = total organic carbon in the sample (kg/L)

KDOC = dissolved organic carbon-water partition coefficient (L/kg),

[DOC] = concentration of dissolved organic carbon in the sample (kg/L).

Site-specific or alternative study-based partition coefficients approved by the Executive Officer may be used for KOC and KDOC in the above equation. If site-specific or alternative study-based partition coefficients are not available or have not been approved, the following partition coefficients shall be used for KOC and KDOC in the above equation:

**Table E-9. Pyrethroid Pesticide Partition Coefficients**

Pyrethroid Pesticide	Receiving water KOC (L/kg)	Receiving water KDOC (L/kg)	Effluent KOC (L/kg)	Effluent KDOC (L/kg)
Bifenthrin	4,228,000	1,737,127	15,848,932	800,000
Cyfluthrin	3,870,000	2,432,071	3,870,000	2,432,071
Cypermethrin	3,105,000	762,765	6,309,573	200,000
Esfenvalerate	7,220,000	1,733,158	7,220,000	1,733,158
Lambda-cyhalothrin	2,056,000	952,809	7,126,428	200,000
Permethrin	6,074,000	957,703	10,000,000	200,000

2. **Water Column Toxicity Monitoring Requirements.** When discharging to the South Fork of Putah Creek or the Arboretum Waterway, the Discharger shall monitor the toxicity of the downstream receiving water using U.S. EPA method U.S. EPA-821-R-02-012 (Methods for Measuring the Acute Toxicity of Effluents and Receiving Waters to Freshwater and Marine Organisms, Fifth Edition, U.S. EPA, October 2002, or most recent edition). Except as specified in this order, water column toxicity testing shall follow the measurement quality objectives provided in the Surface Water Ambient Monitoring Program (SWAMP) Quality Assurance Program Plan (SWRCB, 2018). When feasible, the Discharger shall use the Southern California Coastal Water Research Project (SCCWRP) guidance (Schiff and Greenstein, 2016) on test organism age and size for *Hyalella azteca*.

For consistency with EPA Method EPA-821-R-02-012 and ELAP accreditation, *Hyalella Azteca* water column toxicity testing for baseline monitoring must be performed at 20 degrees Celsius.

**Quarterly monitoring shall be conducted for one year** concurrent with the Pyrethroid Pesticides Water Column Chemistry Monitoring and the Effluent and Receiving Water Characterization Monitoring (see section IX.E of this MRP for specific dates). Downstream receiving water (South Fork of Putah Creek or the Arboretum Waterway) monitoring shall be conducted at monitoring location RSW-D when discharging to the South Fork of Putah Creek or the Arboretum Waterway and the results of such monitoring be submitted to the Central Valley Water Board with the quarterly self-monitoring reports. Monitoring can either be conducted by the Discharger or can be done as part of a group monitoring effort. If the Discharger chooses to participate in a group monitoring effort, the timing of the monitoring can be modified by the Executive Officer.

## **E. Effluent and Receiving Water Characterization**

1. Monitoring Frequency
  - a. **Effluent Sampling.** Samples shall be collected from the effluent (Monitoring Location EFF-001) quarterly between **1 April 2022 and 31 March 2023**.
  - b. **Receiving Water Sampling.** Samples shall be collected from the upstream receiving water (Monitoring Location RSW-U) quarterly between **1 April 2022 and 31 March 2023**.

Constituents shall be collected and analyzed consistent with the Discharger's Analytical Methods Report (MRP, X.D.2) using sufficiently sensitive analytical methods and Reporting Levels per the SSM Rule specified in 40 C.F.R. 122.21(e)(3) and 122.44(i)(1)(iv). The "Reporting Level" is synonymous with the "Method Minimum Level" described in the SSM Rule. The results of the monitoring shall be submitted to the Central Valley Water Board with the quarterly self-monitoring reports. Each individual monitoring event shall provide representative sample results for the effluent and upstream receiving water.

2. **Concurrent Sampling.** Effluent and receiving water sampling shall be performed at approximately the same time, on the same date.
3. **Sample Type.** All receiving water samples shall be taken as grab samples. Effluent samples shall be taken as described in Table E-10, below.
4. **Analytical Methods Report Certification.** Prior to beginning the Effluent and Receiving Water Characterization monitoring, the Discharger shall provide a certification acknowledging the scheduled start date of the Effluent and Receiving Water Characterization monitoring and confirming that samples will be collected and analyzed as described in the previously submitted Analytical Methods Report. If there are changes to the previously submitted Analytical Methods Report, the Discharger shall outline those changes. A one-page certification form will be provided by Central Valley Water Board staff with the permit's Notice of Adoption that the Discharger can use to satisfy this requirement. The certification form shall be submitted electronically via the State Water Board's California Integrated Water Quality System (CIWQS) submittal by the due date in the Technical Reports Table E-12.
5. The Discharger shall conduct effluent and receiving water characterization monitoring in accordance with Table E-10 and the testing requirements described in section IX.D.6 below.

**Table E-10. Effluent and Receiving Water Characterization Monitoring**

**VOLATILE ORGANICS**

CTR Number	Volatile Organic Parameters	CAS Number	Units	Effluent Sample Type
25	2-Chloroethyl vinyl Ether	110-75-8	µg/L	Grab
17	Acrolein	107-02-8	µg/L	Grab
18	Acrylonitrile	107-13-1	µg/L	Grab
19	Benzene	71-43-2	µg/L	Grab
20	Bromoform	75-25-2	µg/L	Grab
21	Carbon Tetrachloride	56-23-5	µg/L	Grab
22	Chlorobenzene	108-90-7	µg/L	Grab
24	Chloroethane	75-00-3	µg/L	Grab
26	Chloroform	67-66-3	µg/L	Grab
35	Methyl Chloride	74-87-3	µg/L	Grab
23	Dibromochloromethane	124-48-1	µg/L	Grab
27	Dichlorobromomethane	75-27-4	µg/L	Grab
36	Methylene Chloride	75-09-2	µg/L	Grab
33	Ethylbenzene	100-41-4	µg/L	Grab
89	Hexachlorobutadiene	87-68-3	µg/L	Grab
34	Methyl Bromide (Bromomethane)	74-83-9	µg/L	Grab
94	Naphthalene	91-20-3	µg/L	Grab
38	Tetrachloroethylene (PCE)	127-18-4	µg/L	Grab

CTR Number	Volatile Organic Parameters	CAS Number	Units	Effluent Sample Type
39	Toluene	108-88-3	µg/L	Grab
40	trans-1,2-Dichloroethylene	156-60-5	µg/L	Grab
43	Trichloroethylene (TCE)	79-01-6	µg/L	Grab
44	Vinyl Chloride	75-01-4	µg/L	Grab
21	Methyl-tert-butyl ether (MTBE)	1634-04-4	µg/L	Grab
41	1,1,1-Trichloroethane	71-55-6	µg/L	Grab
42	1,1,2-Trichloroethane	79-00-5	µg/L	Grab
28	1,1-Dichloroethane	75-34-3	µg/L	Grab
30	1,1-Dichloroethylene (DCE)	75-35-4	µg/L	Grab
31	1,2-Dichloropropane	78-87-5	µg/L	Grab
32	1,3-Dichloropropylene	542-75-6	µg/L	Grab
37	1,1,2,2-Tetrachloroethane	79-34-5	µg/L	Grab
101	1,2,4-Trichlorobenzene	120-82-1	µg/L	Grab
29	1,2-Dichloroethane	107-06-2	µg/L	Grab
75	1,2-Dichlorobenzene	95-50-1	µg/L	Grab
76	1,3-Dichlorobenzene	541-73-1	µg/L	Grab
77	1,4-Dichlorobenzene	106-46-7	µg/L	Grab

**SEMI-VOLATILE ORGANICS**

CTR Number	Semi-Organic Volatile Parameters	CAS Number	Units	Effluent Sample Type
60	Benzo(a)Anthracene	56-55-3	µg/L	Grab
85	1,2-Diphenylhydrazine	122-66-7	µg/L	Grab
45	2-Chlorophenol	95-57-8	µg/L	Grab
46	2,4-Dichlorophenol	120-83-2	µg/L	Grab
47	2,4-Dimethylphenol	105-67-9	µg/L	Grab
49	2,4-Dinitrophenol	51-28-5	µg/L	Grab
82	2,4-Dinitrotoluene	121-14-2	µg/L	Grab
55	2,4,6-Trichlorophenol	88-06-2	µg/L	Grab
83	2,6-Dinitrotoluene	606-20-2	µg/L	Grab
50	2-Nitrophenol	88-75-5	µg/L	Grab
71	2-Chloronaphthalene	91-58-7	µg/L	Grab
78	3,3-Dichlorobenzidine	91-94-1	µg/L	Grab
62	Benzo(b)Fluoranthene	205-99-2	µg/L	Grab
52	4-Chloro-3-methylphenol	59-50-7	µg/L	Grab
48	2-Methyl-4,6-Dinitrophenol	534-52-1	µg/L	Grab
51	4-Nitrophenol	100-02-7	µg/L	Grab
69	4-Bromophenyl Phenyl Ether	101-55-3	µg/L	Grab
72	4-Chlorophenyl Phenyl Ether	7005-72-3	µg/L	Grab
56	Acenaphthene	83-32-9	µg/L	Grab
57	Acenaphthylene	208-96-8	µg/L	Grab
58	Anthracene	120-12-7	µg/L	Grab

CTR Number	Semi-Organic Volatile Parameters	CAS Number	Units	Effluent Sample Type
59	Benzidine	92-87-5	µg/L	Grab
61	Benzo(a)Pyrene	50-32-8	µg/L	Grab
63	Benzo(ghi)Perylene	191-24-2	µg/L	Grab
64	Benzo(k)Fluoranthene	207-08-9	µg/L	Grab
65	Bis (2-Chloroethoxy) Methane	111-91-1	µg/L	Grab
66	Bis (2-Chloroethyl) Ether	111-44-4	µg/L	Grab
67	Bis (2-Chloroisopropyl) Ether	108-60-1	µg/L	Grab
68	Bis(2-Ethylhexyl) Phthalate	117-81-7	µg/L	Grab
70	Butylbenzyl Phthalate	85-68-7	µg/L	Grab
73	Chrysene	218-01-9	µg/L	Grab
81	Di-n-butyl Phthalate	84-74-2	µg/L	Grab
84	Di-n-Octyl Phthalate	117-84-0	µg/L	Grab
74	Dibenzo(a,h)anthracene	53-70-3	µg/L	Grab
79	Diethyl Phthalate	84-66-2	µg/L	Grab
80	Dimethyl Phthalate	131-11-3	µg/L	Grab
86	Fluoranthene	206-44-0	µg/L	Grab
87	Fluorene	86-73-7	µg/L	Grab
88	Hexachlorobenzene	118-74-1	µg/L	Grab
90	Hexachlorocyclopentadiene	77-47-4	µg/L	Grab
91	Hexachloroethane	67-72-1	µg/L	Grab
92	Indeno(1,2,3-cd) Pyrene	193-39-5	µg/L	Grab
93	Isophorone	78-59-1	µg/L	Grab
98	N-Nitrosodiphenylamine	86-30-6	µg/L	Grab
96	N-Nitrosodimethylamine	62-75-9	µg/L	Grab
97	N-Nitrosodi-n-Propylamine	621-64-7	µg/L	Grab
95	Nitrobenzene	98-95-3	µg/L	Grab
53	Pentachlorophenol (PCP)	87-86-5	µg/L	Grab
99	Phenanthrene	85-01-8	µg/L	Grab
54	Phenol	108-95-2	µg/L	Grab
100	Pyrene	129-00-0	µg/L	Grab

**INORGANICS**

CTR Number	Inorganic Parameters	CAS Number	Units	Effluent Sample Type
NL	Aluminum	7429-90-5	µg/L	24-hour Composite
1	Antimony, Total Recoverable	7440-36-0	µg/L	24-hour Composite
2	Arsenic, Total Recoverable	7440-38-2	µg/L	24-hour Composite
15	Asbestos	1332-21-4	µg/L	24-hour Composite
3	Beryllium, Total Recoverable	7440-41-7	µg/L	24-hour Composite
4	Cadmium, Total Recoverable	7440-43-9	µg/L	24-hour Composite
5a (III)	Chromium, Total	7440-47-3	µg/L	24-hour Composite
6	Copper, Total Recoverable	7440-50-8	µg/L	24-hour Composite

CTR Number	Inorganic Parameters	CAS Number	Units	Effluent Sample Type
14	Iron, Total Recoverable	7439-89-6	µg/L	24-hour Composite
7	Lead, Total Recoverable	7439-92-1	µg/L	24-hour Composite
8	Mercury, Total Recoverable	7439-97-6	µg/L	Grab
NL	Mercury, Methyl	22967-92-6	µg/L	Grab
NL	Manganese, Total Recoverable	7439-96-5	µg/L	24-hour Composite
9	Nickel, Total Recoverable	7440-02-0	µg/L	24-hour Composite
10	Selenium, Total Recoverable	7782-49-2	µg/L	24-hour Composite
11	Silver, Total Recoverable	7440-22-4	µg/L	24-hour Composite
12	Thallium, Total Recoverable	7440-28-0	µg/L	24-hour Composite
13	Zinc, Total Recoverable	7440-66-6	µg/L	24-hour Composite

**NON-METALS/MINERALS**

CTR Number	Non-Metal/Mineral Parameters	CAS Number	Units	Effluent Sample Type
NL	Boron	7440-42-8	µg/L	24-hour Composite
NL	Chloride	16887-00-6	mg/L	24-hour Composite
14	Cyanide, Total (as CN)	57-12-5	µg/L	Grab
NL	Phosphorus, Total (as P)	7723-14-0	mg/L	24-hour Composite
NL	Sulfate	14808-79-8	mg/L	24-hour Composite
NL	Sulfide (as S)	5651-88-7	mg/L	24-hour Composite

**PESTICIDES/PCBs/DIOXINS**

CTR Number	Pesticide/PCB/Dioxin Parameters	CAS Number	Units	Effluent Sample Type
110	4,4-DDD	72-54-8	µg/L	24-hour Composite
109	4,4-DDE	72-55-9	µg/L	24-hour Composite
108	4,4-DDT	50-29-3	µg/L	24-hour Composite
112	alpha-Endosulfan	959-98-8	µg/L	24-hour Composite
103	alpha-BHC (Benzene hexachloride)	319-84-6	µg/L	24-hour Composite
102	Aldrin	309-00-2	µg/L	24-hour Composite
113	beta-Endosulfan	33213-65-9	µg/L	24-hour Composite
104	beta-BHC (Benzene hexachloride)	319-85-7	µg/L	24-hour Composite
107	Chlordane	57-74-9	µg/L	24-hour Composite
106	delta-BHC (Benzene hexachloride)	319-86-8	µg/L	24-hour Composite
111	Dieldrin	60-57-1	µg/L	24-hour Composite
114	Endosulfan Sulfate	1031-07-8	µg/L	24-hour Composite
115	Endrin	72-20-8	µg/L	24-hour Composite
116	Endrin Aldehyde	7421-93-4	µg/L	24-hour Composite
117	Heptachlor	76-44-8	µg/L	24-hour Composite
118	Heptachlor Epoxide	1024-57-3	µg/L	24-hour Composite
105	gamma-BHC (Benzene hexachloride or Lindane)	58-89-9	µg/L	24-hour Composite

CTR Number	Pesticide/PCB/Dioxin Parameters	CAS Number	Units	Effluent Sample Type
119	Polychlorinated Biphenyl (PCB) 1016	12674-11-2	µg/L	24-hour Composite
120	PCB 1221	11104-28-2	µg/L	24-hour Composite
121	PCB 1232	11141-16-5	µg/L	24-hour Composite
122	PCB 1242	53469-21-9	µg/L	24-hour Composite
123	PCB 1248	12672-29-6	µg/L	24-hour Composite
124	PCB 1254	11097-69-1	µg/L	24-hour Composite
125	PCB 1260	11096-82-5	µg/L	24-hour Composite
126	Toxaphene	8001-35-2	µg/L	24-hour Composite
16	2,3,7,8-TCDD (Dioxin)	1746-01-6	mg/L	24-hour Composite

**CONVENTIONAL PARAMETERS**

CTR Number	Conventional Parameters	CAS Number	Units	Effluent Sample Type
NL	pH	--	SU	Grab
NL	Temperature	--	°F	Grab

**NON-CONVENTIONAL PARAMETERS**

CTR Number	Nonconventional Parameters	CAS Number	Units	Effluent Sample Type
NL	Foaming Agents (MBAS)	MBAS	mg/L	24-hour Composite
NL	Hardness (as CaCO <sub>3</sub> )	471-34-1	mg/L	Grab
NL	Total Dissolved Solids (TDS)	TDS	mg/L	24-hour Composite
NL	Dissolved Organic Carbon (DOC)	DOC	mg/L	24-hour Composite

**NUTRIENTS**

CTR Number	Nutrient Parameters	CAS Number	Units	Effluent Sample Type
7	Ammonia (as N)	7664-41-7	mg/L	24-hour Composite
8	Nitrate (as N)	14797-55-8	mg/L	24-hour Composite
9	Nitrite (as N)	14797-65-0	mg/L	24-hour Composite

**OTHER CONSTITUENTS OF CONCERN**

CTR Number	Other Constituents of Concern	CAS Number	Units	Effluent Sample Type
NL	1,2,3-Trichloropropane (TCP)	96-18-4	ug/L	Grab
NL	Trichlorofluoromethane	75-69-4	µg/L	Grab
NL	1,1,2-Trichloro-1,2,2-Trifluoroethane	76-13-1	µg/L	Grab
NL	Styrene	100-42-5	µg/L	Grab
NL	Xylenes	1330-20-7	µg/L	Grab



CTR Number	Other Constituents of Concern	CAS Number	Units	Effluent Sample Type
NL	Barium	7440-39-3	µg/L	24-hour Composite
NL	Fluoride	16984-48-8	mg/L	24-hour Composite
NL	Molybdenum	7439-98-7	µg/L	24-hour Composite
NL	Tributyltin	688-73-3	µg/L	24-hour Composite
NL	Alachlor	15972-60-8	µg/L	24-hour Composite
NL	Atrazine	1912-24-9	µg/L	24-hour Composite
NL	Bentazon	25057-89-0	µg/L	24-hour Composite
NL	Carbofuran	1563-66-2	µg/L	24-hour Composite
NL	2,4-D	94-75-7	µg/L	24-hour Composite
NL	Dalapon	75-99-0	µg/L	24-hour Composite
NL	1,2-Dibromo-3-chloropropane (DBCP)	96-12-8	µg/L	24-hour Composite
NL	Di(2-ethylhexyl)adipate	103-23-1	µg/L	24-hour Composite
NL	Dinoseb	88-85-7	µg/L	24-hour Composite
NL	Diquat	85-00-7	µg/L	24-hour Composite
NL	Endothal	145-73-3	µg/L	24-hour Composite
NL	Ethylene Dibromide (EDB)	106-93-4	µg/L	24-hour Composite
NL	Methoxychlor	72-43-5	µg/L	24-hour Composite
NL	Molinate (Ordram)	2212-67-1	µg/L	24-hour Composite
NL	Oxamyl	23135-22-0	µg/L	24-hour Composite
NL	Picloram	1918-02-1	µg/L	24-hour Composite
NL	Simazine (Princep)	122-34-9	µg/L	24-hour Composite
NL	Thiobencarb	28249-77-6	µg/L	24-hour Composite
NL	2,4,5-TP (Silvex)	93-72-1	µg/L	24-hour Composite
NL	Chlorpyrifos	2921-88-2	µg/L	24-hour Composite
NL	Diazinon	333-41-5	µg/L	24-hour Composite

6. **Table E-10 Testing Requirements.** The Discharger shall comply with the following testing requirements when monitoring for the parameters described in Table E-10.

- a. The Discharger is not required to conduct effluent monitoring for ammonia nitrogen, nitrate, and nitrite because this Order already includes at least monthly effluent monitoring for these constituents, as required in Table E-3. Hardness, pH, and temperature shall be conducted with the effluent characterization sampling.
- b. **Applicable to all parameters.** Parameters shall be analyzed using the analytical methods described in 40 CFR part 136 or by methods approved by the Central Valley Water Board or the State Water Board. In addition, if requested by the Discharger, the sample type may be modified by the Executive Officer to another 40 CFR part 136 allowed sample type.
- c. All **24-hour composite** samples shall be collected from a 24-hour flow proportional composite.

- d. A hand-held field meter may be used for **temperature** and **pH**, provided the meter utilizes a U.S. EPA-approved algorithm/method and is calibrated and maintained in accordance with the manufacturer's instructions. A calibration and maintenance log for each meter used for monitoring required by this MRP shall be maintained at the Facility.
- e. Receiving water **temperature** and **pH** shall be recorded at the time of the receiving water **ammonia nitrogen** sample collection.
- f. Receiving water **nitrate and nitrite nitrogen** monitoring shall be conducted concurrently with receiving water **hardness** sampling.
- g. **Hardness** samples shall be collected concurrently with **metals** samples.
- h. **Bis (2-ethylhexyl) phthalate**. In order to verify if bis (2-ethylhexyl) phthalate is truly present, the Discharger shall take steps to assure that sample containers, sampling apparatus, and analytical equipment are not sources of the detected contaminant.
- i. **Total Mercury and Methyl Mercury**. Unfiltered methyl mercury and total mercury samples shall be taken using **clean hands/dirty hands procedures**, as described in U.S. EPA method 1669: Sampling Ambient Water for Trace Metals at EPA Water Quality Criteria Levels, for collection of equipment blanks (section 9.4.4.2). The analysis of methyl mercury and total mercury shall be by U.S. EPA method 1630 and 1631 (Revision E), respectively, with a **reporting limit of 0.05 ng/L for methyl mercury and 0.5 ng/L for total mercury**.

## X. REPORTING REQUIREMENTS

### A. General Monitoring and Reporting Requirements

- 1. The Discharger shall comply with all Standard Provisions (Attachment D) related to monitoring, reporting, and recordkeeping.
- 2. Upon written request of the Central Valley Water Board, the Discharger shall submit a summary monitoring report. The report shall contain both tabular and graphical summaries of the monitoring data obtained during the previous year(s).
- 3. **Compliance Time Schedules**. For compliance time schedules included in the Order, the Discharger shall submit to the Central Valley Water Board, on or before each compliance due date, the specified document or a written report detailing compliance or noncompliance with the specific date and task. If noncompliance is reported, the Discharger shall state the reasons for noncompliance and include an estimate of the date when the Discharger will be in compliance. The Discharger shall notify the Central Valley Water Board by letter when it returns to compliance with the compliance time schedule.
- 4. The Discharger shall report to the Central Valley Water Board any toxic chemical release data it reports to the State Emergency Response Commission

within 15 days of reporting the data to the Commission pursuant to section 313 of the "Emergency Planning and Community Right to Know Act" of 1986.

**B. Self-Monitoring Reports (SMRs)**

1. The Discharger shall electronically submit SMRs using the State Water Board's [California Integrated Water Quality System \(CIWQS\) Program website](http://www.waterboards.ca.gov/water_issues/programs/ciwqs/) ([http://www.waterboards.ca.gov/water\\_issues/programs/ciwqs/](http://www.waterboards.ca.gov/water_issues/programs/ciwqs/)). The CIWQS website will provide additional information for SMR submittal in the event there will be a planned service interruption for electronic submittal.
2. The Discharger shall report in the SMR the results for all monitoring specified in this MRP under sections III through IX. The Discharger shall submit monthly SMRs including the results of all required monitoring using U.S. EPA-approved test methods or other test methods specified in this Order. SMRs are to include all new monitoring results obtained since the last SMR was submitted. If the Discharger monitors any pollutant more frequently than required by this Order, the results of this monitoring shall be included in the calculations and reporting of the data submitted in the SMR. Monthly SMRs are required even if there is no discharge. If no discharge occurs during the month, the monitoring report must be submitted stating that there has been no discharge.
3. Monitoring periods and reporting for all required monitoring shall be completed according to the following schedule:

**Table E-11. Monitoring Periods and Reporting Schedule**

Sampling Frequency	Monitoring Period Begins	Monitoring Period	SMR Due Date
Continuous	Permit effective date	All	Submit with monthly SMR
1/Day	Permit effective date	(Midnight through 11:59 PM) or any 24-hour period that reasonably represents a calendar day for purposes of sampling.	Submit with monthly SMR
1/Week	Permit effective date	Sunday through Saturday	Submit with monthly SMR
2/Week	Permit effective date	Sunday through Saturday	Submit with monthly SMR
3/Week	Permit effective date	Sunday through Saturday	Submit with monthly SMR
1/Month	Permit effective date	1st day of calendar month through last day of calendar month	First day of second calendar month following month of sampling

Sampling Frequency	Monitoring Period Begins	Monitoring Period	SMR Due Date
1/Quarter	Permit effective date	1 January through 31 March 1 April through 30 June 1 July through 30 September 1 October through 31 December	1 May 1 August 1 November 1 February of following year
1/Year	Permit effective date	1 January through 31 December	1 February of following year

4. **Reporting Protocols.** The Discharger shall report with each sample result the applicable Reporting Level (RL) and the current laboratory’s Method Detection Limit (MDL), as determined by the procedure in 40 C.F.R. part 136.

The Discharger shall report the results of analytical determinations for the presence of chemical constituents in a sample using the following reporting protocols:

- a. Sample results greater than or equal to the RL shall be reported as measured by the laboratory (i.e., the measured chemical concentration in the sample).
- b. Sample results less than the RL, but greater than or equal to the laboratory’s MDL, shall be reported as “Detected, but Not Quantified,” or DNQ. The estimated chemical concentration of the sample shall also be reported.

For the purposes of data collection, the laboratory shall write the estimated chemical concentration next to DNQ. The laboratory may, if such information is available, include numerical estimates of the data quality for the reported result. Numerical estimates of data quality may be percent accuracy ( $\pm$  a percentage of the reported value), numerical ranges (low to high), or any other means considered appropriate by the laboratory.

- c. Sample results less than the laboratory’s MDL shall be reported as “Not Detected,” or ND.
- d. Dischargers are to instruct laboratories to establish calibration standards so that the Minimum Level (ML) value (or its equivalent if there is differential treatment of samples relative to calibration standards) is the lowest calibration standard. At no time is the Discharger to use analytical data derived from extrapolation beyond the lowest point of the calibration curve.

5. **Multiple Sample Data.** When determining compliance with an average monthly eluent limitation (AMEL), average weekly effluent limitation (AWEL), maximum daily effluent limitation (MDEL), or average annual effluent limitation (AAEL) for priority pollutants and more than one sample result is available, the Discharger

shall compute the arithmetic mean unless the data set contains one or more reported determinations of “Detected, but Not Quantified” (DNQ) or “Not Detected” (ND). In those cases, the Discharger shall compute the median in place of the arithmetic mean in accordance with the following procedure:

- a. The data set shall be ranked from low to high, ranking the reported ND determinations lowest, DNQ determinations next, followed by quantified values (if any). The order of the individual ND or DNQ determinations is unimportant.
  - b. The median value of the data set shall be determined. If the data set has an odd number of data points, then the median is the middle value. If the data set has an even number of data points, then the median is the average of the two values around the middle unless one or both of the points are ND or DNQ, in which case the median value shall be the lower of the two data points where DNQ is lower than a value and ND is lower than DNQ.
6. The Discharger shall submit SMRs in accordance with the following requirements:
- a. The Discharger shall arrange all reported data in a tabular format. The data shall be summarized to clearly illustrate whether the Facility is operating in compliance with interim and/or final effluent limitations. The Discharger is not required to duplicate the submittal of data that is entered in a tabular format within CIWQS. When electronic submittal of data is required and CIWQS does not provide for entry into a tabular format within the system, the Discharger shall electronically submit the data in a tabular format as an attachment.
  - b. The Discharger shall attach a cover letter to the SMR. The information contained in the cover letter shall clearly identify violations of the waste discharge requirements; discuss corrective actions taken or planned; and the proposed time schedule for corrective actions. Identified violations must include a description of the requirement that was violated and a description of the violation.
  - c. The Discharger shall attach all final laboratory reports from all contracted commercial laboratories, including quality assurance/quality control information, with all its SMRs for which sample analyses were performed.
7. The Discharger shall submit in the SMRs calculations and reports in accordance with the following requirements:
- a. **Average Dry Weather Flow.** The Discharger shall calculate and report the average dry weather flow for the effluent. The average dry weather flow shall be calculated as specified in section VII.C of the Waste Discharge Requirements and reported in the December SMR.
  - b. **Calendar Average Annual Effluent Limitations.** For constituents with effluent limitations specified as “calendar average annual” (electrical

conductivity) the Discharger shall report the calendar average annual in the December SMR. The calendar average annual shall be calculated as the average of the samples gathered for the calendar year.

- c. **Mass Loading Limitations.** For ammonia, the Discharger shall calculate and report the mass loading (lbs/day) in the SMRs. The mass loading shall be calculated as follows:

$$\text{Mass Loading (lbs/day)} = \text{Flow (MGD)} \times \text{Concentration (mg/L)} \times 8.34$$

When calculating daily mass loading, the daily average flow and constituent concentration shall be used. For weekly average mass loading, the weekly average flow and constituent concentration shall be used. For monthly average mass loading, the monthly average flow and constituent concentration shall be used.

- d. **Removal Efficiency (BOD<sub>5</sub> and TSS).** The Discharger shall calculate and report the percent removal of BOD<sub>5</sub> and TSS in the SMRs. The percent removal shall be calculated as specified in section VII.A of the Waste Discharge Requirements.
- e. **Total Coliform Organisms Effluent Limitations.** The Discharger shall calculate and report the 7-day median of total coliform organisms for the effluent. The 7-day median of total coliform organisms shall be calculated as specified in section VII.D of the Waste Discharge Requirements.
- f. **Dissolved Oxygen Receiving Water Limitations.** The Discharger shall report monthly in the SMR the dissolved oxygen concentrations in the effluent (EFF-001) and the receiving water (RSW-U and RSW-D).
- g. **Turbidity Receiving Water Limitations.** The Discharger shall calculate and report the turbidity increase in the receiving water applicable to the natural turbidity condition specified in section V.A.16.a-e of the Waste Discharge Requirements.
- h. **Temperature Receiving Water Limitations.** The Discharger shall calculate and report the temperature increase in the receiving water based on the difference in temperature at Monitoring Locations RSW-U and RSW-D.

### C. Discharge Monitoring Reports (DMR's)

1. DMRs are U.S. EPA reporting requirements. The Discharger shall electronically certify and submit DMR's together with SMR's using Electronic Self-Monitoring Reports module eSMR 2.5 or any upgraded version. Electronic DMR submittal will be in addition to electronic SMR submittal.  
[Information about electronic DMR submittal](http://www.waterboards.ca.gov/water_issues/programs/discharge_monitoring/)  
([http://www.waterboards.ca.gov/water\\_issues/programs/discharge\\_monitoring/](http://www.waterboards.ca.gov/water_issues/programs/discharge_monitoring/)) is available on the Internet.

#### D. Other Reports

1. **Analytical Methods Report.** The Discharger shall complete and submit an Analytical Methods Report, electronically via CIWQS submittal, by the due date shown in the Technical Reports Table E-12. The Analytical Methods Report shall include the following for each constituent to be monitored in accordance with this Order: 1) applicable water quality objective, 2) reporting level (RL), 3) method detection limit (MDL), and 4) analytical method. The analytical methods shall be sufficiently sensitive with RLs consistent with the SSM Rule per 40 C.F.R. 122.21(e)(3) and 122.44(i)(1)(iv), and with the Minimum Levels (MLs) in the SIP, Appendix 4. The “Reporting Level or RL” is synonymous with the “Method Minimum Level” described in the SSM Rule. If an RL is not less than or equal to the applicable water quality objective for a constituent, the Discharger shall explain how the proposed analytical method complies with the SSM Rule. Central Valley Water Board staff will provide a tool with the permit’s Notice of Adoption to assist the Discharger in completing this requirement. The tool will include the constituents and associated applicable water quality objectives to be included in the Analytical Methods Report.
2. **Annual Operations Report.** The Discharger shall submit a written report to the Central Valley Water Board, electronically via CIWQS submittal, containing the following by the due date in the Technical Reports Table E-12:
  - a. The names, certificate grades, and general responsibilities of all persons employed at the Facility.
  - b. The names and telephone numbers of persons to contact regarding the plant for emergency and routine situations.
  - c. A statement certifying when the flow meter(s) and other monitoring instruments and devices were last calibrated, including identification of who performed the calibration.
  - d. A statement certifying whether the current operation and maintenance manual, and contingency plan, reflect the wastewater treatment plant as currently constructed and operated, and the dates when these documents were last revised and last reviewed for adequacy.
  - e. The Discharger may also be requested to submit an annual report to the Central Valley Water Board with both tabular and graphical summaries of the monitoring data obtained during the previous year. Any such request shall be made in writing. The report shall discuss the compliance record. If violations have occurred, the report shall also discuss the corrective actions taken and planned to bring the discharge into full compliance with the waste discharge requirements.
3. **Report of Waste Discharge (ROWD).** For the 5-year permit renewal, the Discharger shall submit a written report to the Central Valley Water Board, electronically via CIWQS submittal, containing, at minimum, the following by the due date in the Technical Reports Table E-12:

- a. Report of Waste Discharge (Form 200);
  - b. NPDES Form 1;
  - c. NPDES Form 2A; and
  - d. NPDES Form 2S;
  - e. **Salinity Evaluation and Minimization Plan.** The Discharger shall evaluate the effectiveness of the salinity evaluation and minimization plan and provide a summary with the Report of Waste Discharge.
4. **Recycled Water Policy Annual Reports.** In accordance with Section 3 of the Water Quality Control Policy for Recycled Water (Recycled Water Policy), the Discharger shall electronically submit an annual report of monthly data to the State Water Board by 30 April annually covering the previous calendar year using the State Water Board’s [GeoTracker website](https://geotracker.waterboards.ca.gov/) (<https://geotracker.waterboards.ca.gov/>). Information for setting up and using the GeoTracker system can be found in the ESI Guide for Responsible Parties document on the State Water Board’s website for [Electronic Submittal of Information](https://www.waterboards.ca.gov/ust/electronic_submittal/index.html) ([https://www.waterboards.ca.gov/ust/electronic\\_submittal/index.html](https://www.waterboards.ca.gov/ust/electronic_submittal/index.html)).

The annual report to GeoTracker must include volumetric reporting of the items listed in Section 3.2 of the [Recycled Water Policy](https://www.waterboards.ca.gov/board_decisions/adopted_orders/resolutions/2018/121118_7_final_amendment_oal.pdf) ([https://www.waterboards.ca.gov/board\\_decisions/adopted\\_orders/resolutions/2018/121118\\_7\\_final\\_amendment\\_oal.pdf](https://www.waterboards.ca.gov/board_decisions/adopted_orders/resolutions/2018/121118_7_final_amendment_oal.pdf)). A PDF of the upload confirmation from GeoTracker for the Recycled Water Policy Annual Report shall be uploaded into CIWQS to demonstrate compliance with this reporting requirement.

5. **Technical Report Submittals.** This Order includes requirements to submit a ROWD, special study technical reports, progress reports, and other reports identified in the MRP (hereafter referred to collectively as “technical reports”). The Technical Reports Table below summarizes all technical reports required by this Order and the due dates for submittal. All technical reports shall be submitted electronically via CIWQS submittal. Technical reports should be uploaded as a PDF, Microsoft Word, or Microsoft Excel file attachment.

**Table E-12. Technical Reports**

Report #	Technical Report	Due Date	CIWQS Report Name
Intentionally left blank	Standard Reporting Requirements	Intentionally left blank	Intentionally left blank
1	Report of Waste Discharge	31 March 2025	MRP X.D.4
2	Analytical Methods Report	20 April 2021	MRP X.D.2
3	Analytical Methods Report Certification	1 January 2022	MRP IX.D.4



Report #	Technical Report	Due Date	CIWQS Report Name
4	Annual Operations Report	1 February 2022	MRP X.D.3
5	Annual Operations Report	1 February 2023	MRP X.D.3
6	Annual Operations Report	1 February 2024	MRP X.D.3
7	Annual Operations Report	1 February 2025	MRP X.D.3
8	Annual Operations Report	1 February 2026	MRP X.D.3
9	Recycled Water Policy Annual Report Submittal Confirmation	30 April 2021	MRP X.D.4
10	Recycled Water Policy Annual Report Submittal Confirmation	30 April 2022	MRP X.D.4
11	Recycled Water Policy Annual Report Submittal Confirmation	30 April 2023	MRP X.D.4
12	Recycled Water Policy Annual Report Submittal Confirmation	30 April 2024	MRP X.D.4
13	Recycled Water Policy Annual Report Submittal Confirmation	30 April 2025	MRP X.D.4
14	Results of Most Sensitive Species Rescreening (if significant change in the nature of the discharge)	45 days following the last chronic toxicity test for rescreening	MRP V.E
15	Results of Most Sensitive Species Rescreening	31 March 2025	MRP V.E
Intentionally left blank	Compliance Schedule for Final Effluent Limitations for Chronic Toxicity (WDR section VI.C.7.a)	Intentionally left blank	Intentionally left blank
16	<b>Submit Method of Compliance Workplan.</b> Submit workplan that ensures compliance with final effluent limitation for chronic toxicity by the final compliance date.	16 June 2021	WDR VI.C.7.a
17	<b>Final Compliance.</b> Submit report demonstrating compliance with the final effluent limitation for chronic toxicity.	31 March 2028	WDR VI.C.7.a

Report #	Technical Report	Due Date	CIWQS Report Name
18	<b>Annual Progress Report.</b> The progress reports shall detail what steps have been implemented towards achieving compliance with waste discharge requirements, including studies, construction progress, evaluation of measures implemented, and recommendations for additional measures as necessary to achieve full compliance by the final compliance date.	28 February 2022	WDR VI.C.7.a
19	Annual Progress Report.	28 February 2023	WDR VI.C.7.a
20	Annual Progress Report.	28 February 2024	WDR VI.C.7.a
21	Annual Progress Report.	28 February 2025	WDR VI.C.7.a
22	Annual Progress Report.	28 February 2026	WDR VI.C.7.a
23	Annual Progress Report.	28 February 2027	WDR VI.C.7.a

## ATTACHMENT F – FACT SHEET

### Table of Contents

I.	Permit Information .....	3
II.	Facility Description .....	5
	A. Description of Wastewater and Biosolids Treatment and Controls .....	5
	B. Discharge Points and Receiving Waters.....	5
	C. Summary of Existing Requirements and Self-Monitoring Report (SMR) Data .....	6
	D. Compliance Summary.....	9
	E. Planned Changes .....	9
III.	Applicable Plans, Policies, and Regulations.....	9
	A. Legal Authorities .....	9
	B. California Environmental Quality Act (CEQA) .....	9
	C. State and Federal Laws, Regulations, Policies, and Plans .....	10
	D. Impaired Water Bodies on CWA 303(d) List .....	13
	E. Other Plans, Polices and Regulations.....	14
IV.	Rationale For Effluent Limitations and Discharge Specifications.....	14
	A. Discharge Prohibitions .....	15
	B. Technology-Based Effluent Limitations.....	16
	1. Scope and Authority.....	16
	2. Applicable Technology-Based Effluent Limitations .....	17
	C. Water Quality-Based Effluent Limitations (WQBELs).....	18
	1. Scope and Authority.....	18
	2. Applicable Beneficial Uses and Water Quality Criteria and Objectives .....	19
	3. Determining the Need for WQBELs .....	27
	4. WQBEL Calculations .....	45
	5. Whole Effluent Toxicity (WET) .....	47
	D. Final Effluent Limitation Considerations.....	51
	1. Mass-based Effluent Limitations .....	51
	2. Averaging Periods for Effluent Limitations .....	51
	3. Satisfaction of Anti-Backsliding Requirements.....	51
	4. Antidegradation Policies .....	53
	5. Stringency of Requirements for Individual Pollutants.....	54
	E. Interim Effluent Limitations.....	56
	F. Land Discharge Specifications – Not Applicable.....	58
	G. Recycling Specifications – Not Applicable .....	58
V.	Rationale for Receiving Water Limitations.....	58
	A. Surface Water.....	58
	B. Groundwater .....	59
VI.	Rationale for Provisions.....	59
	A. Standard Provisions.....	59
	B. Special Provisions.....	60
	1. Reopener Provisions.....	60
	2. Special Studies and Additional Monitoring Requirements.....	61
	3. Best Management Practices and Pollution Prevention .....	64

4. Construction, Operation, and Maintenance Specifications.....	64
5. Special Provisions for Publicly-Owned Treatment Works (POTWs) .....	66
6. Other Special Provisions.....	67
7. Compliance Schedules .....	67
VII. Rationale for Monitoring and Reporting Requirements.....	69
A. Influent Monitoring .....	69
B. Effluent Monitoring.....	69
C. Whole Effluent Toxicity Testing Requirements .....	71
D. Receiving Water Monitoring.....	71
1. Surface Water.....	71
2. Groundwater .....	71
E. Other Monitoring Requirements.....	72
VIII. Public Participation .....	73
A. Notification of Interested Persons .....	73
B. Written Comments .....	73
C. Public Hearing .....	73
D. Reconsideration of Waste Discharge Requirements.....	73
E. Information and Copying.....	74
F. Register of Interested Persons .....	74
G. Additional Information .....	74

**Tables**

Table F-1. Facility Information .....	3
Table F-2. Historic Effluent Limitations .....	7
Table F-3 Basin Plan Beneficial Uses .....	10
Table F-4. 303 (d) List for Putah Creek .....	14
Table F-5. Summary of Technology-based Effluent Limitations .....	17
Table F-6. Summary of CTR Criteria for Hardness-dependent Metals .....	22
Table F-7. Verification of CTR Compliance for Copper .....	27
Table F-8. Verification of CTR Compliance for Silver .....	27
Table F-9. Salinity Water Quality Criteria/Objectives.....	30
Table F-10. Summary of Water Quality-Based Effluent Limitations.....	47
Table F-11. Whole Effluent Chronic Toxicity Testing Results.....	49
Table F-12. Summary of Final Effluent Limitations .....	55

**ATTACHMENT F – FACT SHEET**

As described in section II.B of this Order, the Central Valley Water Board incorporates this Fact Sheet as findings of the Central Valley Water Board supporting the issuance of this Order. This Fact Sheet discusses the legal requirements and technical rationale that serve as the basis for the requirements of this Order.

This Order has been prepared under a standardized format to accommodate a broad range of discharge requirements for Dischargers in California. Only those sections or subsections of this Order that are specifically identified as “not applicable” have been determined not to apply to this Discharger. Sections or subsections of this Order not specifically identified as “not applicable” are fully applicable to this Discharger.

**I. PERMIT INFORMATION**

The following table summarizes administrative information related to the Facility.

**Table F-1. Facility Information**

<b>Waste Discharge ID:</b>	5A570800001
<b>CIWQS Facility Place ID:</b>	268926
<b>Discharger:</b>	Regents, University of California
<b>Name of Facility:</b>	University of California, Davis Wastewater Treatment Plant
<b>Facility Address:</b>	561 Trotter Way
<b>Facility City, State Zip:</b>	Davis, California 95616
<b>Facility County:</b>	Solano and Yolo Counties
<b>Facility Contact, Title and Phone Number:</b>	Michael Fan, Utilities Director, (530) 752-7553
<b>Authorized Person to Sign and Submit Reports:</b>	Michael Fan, Utilities Director, (530) 752-7553
<b>Mailing Address:</b>	Utilities Headquarters One Shields Avenue, Davis, CA 95616
<b>Billing Address:</b>	SAME as Mailing Address
<b>Type of Facility:</b>	Publicly Owned Treatment Works (POTW)
<b>Major or Minor Facility:</b>	Major
<b>Threat to Water Quality:</b>	1
<b>Complexity:</b>	A
<b>Pretreatment Program:</b>	Not Applicable
<b>Recycling Requirements:</b>	Not Applicable
<b>Facility Permitted Flow:</b>	3.6 million gallons per day (MGD), average dry weather flow (ADWF)
<b>Facility Design Flow:</b>	3.6 MGD, ADWF
<b>Watershed:</b>	Lower Sacramento

<b>Receiving Water:</b>	South Fork of Putah Creek
<b>Receiving Water Type:</b>	Inland Surface Water

- A.** Regents, University of California Davis is the owner (hereinafter Discharger) and the University of California, Davis is the operator of the University of California, Davis Wastewater Treatment Plant (hereinafter Facility), a POTW.

For the purposes of this Order, references to the “discharger” or “permittee” in applicable federal and state laws, regulations, plans, or policy are held to be equivalent to references to the Discharger herein.

- B.** The Facility discharges wastewater to the South Fork of Putah Creek (Discharge Point 001), a water of the United States within the Lower Sacramento Watershed, and to the Arboretum Waterway (Discharge Point 002), a water of the State and formerly known as the North Fork of Putah Creek. The Discharger was previously regulated by Order R5-2014-0152 and National Pollutant Discharge Elimination System (NPDES) Permit No. CA0077895 adopted on 5 December 2014 and expired on 31 January 2020. Attachment B provides a map of the area around the Facility. Attachment C provides a flow schematic of the Facility.
- C.** When applicable, state law requires dischargers to file a petition with the State Water Board, Division of Water Rights and receive approval for any change in a point of discharge, place of use, or purpose of use of treated wastewater that decreases the flow in any portion of a watercourse. The State Water Board retains separate jurisdictional authority to enforce any applicable requirements under Water Code section 1211. This is not an NPDES permit requirement.
- D.** The Discharger filed a Notice of Intent application for regulatory coverage under the Municipal General Wastewater Requirements Order (MGO) R5-2017-0085 on 24 July 2019. Central Valley Water Board staff determined the discharge was not eligible for the MGO R5-2017-0085 and proposed to reissue the Discharger’s waste discharge requirements (WDRs) and NPDES permit as an individual permit. The Notice of Intent meets the requirements of the report of waste discharge (ROWD) The Discharger also submitted U.S. EPA NPDES forms 1, 2A, and 2S. The application was deemed complete on 31 July 2019. A site visit was conducted on 13 December 2019, to observe operations and collect additional data to develop permit limitations and requirements for waste discharge.
- E.** Regulations at 40 C.F.R. section 122.46 limit the duration of NPDES permits to a fixed term not to exceed five years. Accordingly, Table 3 of this Order limits the duration of the discharge authorization. Under 40 C.F.R. section 122.6(d), States authorized to administer the NPDES program may administratively continue State-issued permits beyond their expiration dates until the effective date of the new permits, if State law allows it. Pursuant to California Code of Regulations, title 23, section 2235.4, the terms and conditions of an expired permit are automatically continued pending reissuance of the permit if the Discharger complies with all federal NPDES requirements for continuation of expired permits.

## II. FACILITY DESCRIPTION

The Discharger provides sewerage service for the University of California, Davis and serves a campus population of approximately 48,000. The design daily average flow capacity of the Facility is 3.6 MGD.

### A. Description of Wastewater and Biosolids Treatment and Controls

The treatment system at the Facility consists of manual and mechanical bar screens; an oxidation ditch activated sludge process with nitrification and denitrification, secondary clarifiers, gravity sand filter, disk cloth filter, and ultraviolet light (UV) disinfection system. Biosolids treatment consists of solids stabilization basins and sludge drying beds. Each summer, stabilized sludge is pumped into the drying beds for dewatering. Dewatered biosolids are transported and disposed at the Yolo County Central Landfill, a Class III non-hazardous municipal landfill as daily cover. Dried biosolids are stored onsite at the location(s) identified in Attachment C and are hauled to a landfill for disposal. Transportation and disposal/reuse of the biosolids is regulated by U.S. EPA under 40 C.F.R. part 503.

### B. Discharge Points and Receiving Waters

1. The Facility is located in Section 21, T8N, R2E, MDB&M, as shown in Attachment B, a part of this Order.
2. Treated municipal wastewater is discharged at Discharge Point No. 001 to the South Fork of Putah Creek, a water of the United States and a tributary to the Sacramento River, at a point latitude 38° 31' 2.7" N and longitude 121° 45' 26.7" W.
3. Treated municipal wastewater is also discharged at Discharge Point 002 to the Arboretum Waterway, a water of the state and a tributary to the South Fork of Putah Creek, at a point latitude 38° 31' 56.3" N and longitude 121° 45' 23.2" W.

The Arboretum Waterway exists within a channel that was originally a part of the North Fork of Putah Creek. The lower reach of Putah Creek historically branched into a North Fork and a South Fork. The original North Fork of Putah Creek flowed through the City of Davis where the University is located, but for flood control the North Fork was dammed near the junction with the South Fork channel, rerouting all Putah Creek flow south of town through the South Fork of Putah Creek. Today, the original North Fork channel of Putah Creek is known as the Arboretum Waterway. The Arboretum Waterway is still located on the University and is confined at both ends and used for storm water management purposes. For storm water management purposes, water in the Arboretum Waterway is pumped to a discharge point on the South Fork of Putah Creek, upstream of Discharge Point 001. During dry weather, the arboretum water becomes stagnant and fills with algae. The Facility discharge at Discharge Point 002 provides the benefit of freshening up the Arboretum Waterway and improving the water quality in the Arboretum Waterway.

Previous Orders R5-2003-0003 and R5-2008-0183 classified the Arboretum Waterway as a water of the United States. In Order R5-2003-0003, the Central Valley Water Board authorized the discharge of up to 2.7 MGD of tertiary treated wastewater commingled with arboretum water to the Arboretum Waterway as a reclamation discharge, but indicated that the discharge of reclaimed water from the Arboretum Waterway to the South Fork of Putah Creek may constitute a wastewater discharge requiring an NPDES permit.

In Order R5-2008-0183, the Central Valley Water determined that the discharge of tertiary treated wastewater to the Arboretum Waterway is a surface water discharge, thus losing the label “reclaimed water” as the discharge enters the Arboretum Waterway, and that the regulation of the downstream discharge from the Arboretum Waterway to the South Fork of Putah Creek, which includes storm water, is outside the scope of the permit and should be regulated by the NPDES Storm Water Program. Order R5-2008-0183 authorized the discharge of up to 3.6 MGD of tertiary treated wastewater to the Arboretum Waterway for 3 years following the adoption date (i.e., 5 December 2011), after which discharges to the waterway were prohibited. Order R5-2008-0183 included a reopener to modify the prohibition to allow discharges upon completion of a constituent study and an antidegradation analysis.

The Discharger completed the Constituent Study in 2009 and submitted an Antidegradation Analysis on 7 September 2010. The Discharger contacted DWR regarding the plan to reestablish the discharge to the Arboretum Waterway. The DWR approved the discharge on 8 August 2014 and informed the Discharger that a wastewater change petition was not required. Based on the results of the Antidegradation Analysis and the approval from DWR, Order R5-2014-0152 authorized discharges to the Arboretum Waterway at Discharge Point 002. This Order carries forward the authorized discharge at Discharge Point 002.

The Army Corps of Engineers (ACOE) concluded in a 14 June 1995 letter that the Arboretum Waterway is not a water of the United States. Consistent with the ACOE determination, the Arboretum Waterway is not considered a water of the United States for the purposes of this Order. However, the Arboretum Waterway is a water of the state. Consequently, this Order retains effluent limitations for discharges to the Arboretum Waterway at Discharge Point 002 and receiving water limitations for the South Fork of Putah Creek which the Arboretum Waterway is pumped into, which are necessary to protect the beneficial uses.

### **C. Summary of Existing Requirements and Self-Monitoring Report (SMR) Data**

1. Effluent limitations contained in Order R5-2014-0152 for discharges from Discharge Points 001 and 002 (Monitoring Location EFF-001) and



representative monitoring data from the term of Order R5-2014-0152 are as follows:

**Table F-2. Historic Effluent Limitations**

Parameter	Units	Historic Effluent Limitations	Highest Average Monthly Discharge	Highest Average Weekly Discharge	Highest Daily Discharge
Biochemical Oxygen Demand, 5-day @ 20°Celsius (BOD <sub>5</sub> )	mg/L	AMEL 10 AWEL 15 MDEL 20	6.4	7.3	10
BOD <sub>5</sub>	lbs/day	AMEL 300 AWEL 450 MDEL 600	59	67	98
BOD <sub>5</sub>	% removal	Average Monthly greater than or equal to 85	95	--	--
pH	standard units	Instantaneous Max 8.3 Instantaneous Min 6.5	--	--	6.5 - 8.0
Total Suspended Solids (TSS)	mg/L	AMEL 10 AWEL 15 MDEL 20	2.7	4.0	8.0
TSS	lbs/day	AMEL 300 AWEL 450 MDEL 600	30	45	101
TSS	% removal	Average Monthly greater than or equal to 85	96	--	--
Ammonia Nitrogen, Total (as N) (1 May – 31 October)	mg/L	AMEL 0.70 MDEL 1.6	0.39 DNQ	--	1.4
Ammonia Nitrogen, Total (as N) (1 May – 31 October)	lbs/day	AMEL 21 MDEL 48	3.7	--	18
Ammonia Nitrogen, Total (as N) (1 November – 30 April)	mg/L	AMEL 0.95 MDEL 2.9	0.16	--	1.2

Parameter	Units	Historic Effluent Limitations	Highest Average Monthly Discharge	Highest Average Weekly Discharge	Highest Daily Discharge
Ammonia Nitrogen, Total (as N) (1 November – 30 April)	lbs/day	AMEL 29 MDEL 87	2.9	--	14
Nitrate plus Nitrite (as N)	mg/L	AMEL 10	9.86	--	--
Acute Whole Effluent Toxicity (WET)	% survival	70 minimum any one bioassay; 90 median any 3 consecutive	98; 99	--	--
Total Residual Chlorine	mg/L	0.011 4-day average; 0.019 1-hour average		--	N/A
Total Coliform Organisms	MPN/100 mL	2.2 as 7-day median; 23 more than once/30-day period; 240 at any time	--	--	17
Average Dry Weather Flow	MGD	3.6	2.9	--	--
Mercury, Total	lbs/year	0.10	0.000015	--	--
Electrical Conductivity @ 25°Celsius	µmhos/cm	AAEL 1,100	1091	--	--

**Table F-2 Notes:**

1. **BOD<sub>5</sub> and TSS percent removal** represents the minimum monthly percent removal.
2. **DNQ** is detected but not quantified.
3. **Acute Whole Effluent Toxicity percent survival** represents minimum observed percent survival.
4. **Total Residual Chlorine.** Chlorine was not used in the treatment process and therefore, monitoring was not required.
5. **Average Dry Weather Flow.** The highest average monthly discharge represents the highest observed average dry weather flow.
6. **Total Mercury.** The highest average monthly discharge represents the highest calculated calendar year annual mass load.
7. **Electrical Conductivity @ 25 degrees Celsius.** The highest average monthly discharge represents the highest observed calendar year annual average.

#### **D. Compliance Summary**

1. Compliance inspections of the Facility were conducted on 1 September 2016 and 24 August 2017. During each inspection Central Valley Water Board staff found no violations or areas of concern.
2. Effluent from the Facility continues to cause ongoing, intermittent compliance issues with toxicity. In 2017, Facility staff implemented a Toxicity Identification Evaluation and Toxicity Reduction Evaluation (TIE/TRE) Plan, but results were inconclusive. The TIE/TRE Plan was reinitiated following chronic toxicity failure for *C. dubia* during the routine fourth quarter 2018 monitoring. Results were again inconclusive. The Discharger is participating in the Central Valley Clean Water Association Toxicity Special Project and is communicating with other Central Valley dischargers to best understand how to rectify the continuing low-level toxicity issues.

#### **E. Planned Changes**

1. The Discharger is planning for an expansion in campus population from 47,469 (in 2016/17) to 56,896 by 2030/31. However, the Facility has sufficient capacity to handle campus population growth and is not projected to reach 75 percent of the hydraulic capacity within the next 5 years.
2. The Discharger is planning to replace the existing UV disinfection system. The current system has reached the end of its useful life, experiences operations and maintenance challenges, and has increasing reliability risks due to equipment obsolescence. A preliminary replacement evaluation has been completed and a design consultant was selected in July 2019 through a competitive selection process. Construction is expected to begin in late 2021.

### **III. APPLICABLE PLANS, POLICIES, AND REGULATIONS**

The requirements contained in this Order are based on the requirements and authorities described in this section.

#### **A. Legal Authorities**

This Order serves as WDRs pursuant to article 4, chapter 4, division 7 of the California Water Code (commencing with section 13260). This Order is also issued pursuant to section 402 of the federal Clean Water Act (CWA) and implementing regulations adopted by the U.S. EPA and chapter 5.5, division 7 of the Water Code (commencing with section 13370). It shall serve as an NPDES permit for point source discharges from this Facility to surface waters.

#### **B. California Environmental Quality Act (CEQA)**

Under Water Code section 13389, this action to adopt an NPDES permit is exempt from the provisions of Chapter 3 of CEQA, (commencing with section 21100) of Division 13 of the Public Resources Code.

**C. State and Federal Laws, Regulations, Policies, and Plans**

1. **Water Quality Control Plan.** Requirements of this Order specifically implement the applicable Water Quality Control Plans.
  - a. **Basin Plan.** The Central Valley Water Board adopted a Water Quality Control Plan for the Sacramento River and San Joaquin River Basins, Fifth Edition, May 2018 (hereinafter Basin Plan) that designates beneficial uses, establishes water quality objectives, and contains implementation programs and policies to achieve those objectives for all waters addressed through the plan. Requirements in this Order implement the Basin Plan. In addition, the Basin Plan implements State Water Board Resolution 88-63, which established state policy that all waters, with certain exceptions, should be considered suitable or potentially suitable for municipal or domestic supply. Beneficial uses applicable to the South Fork of Putah Creek are as follows:

**Table F-3 Basin Plan Beneficial Uses**

Discharge Points	Receiving Water Name	Beneficial Use(s)
001 and 002	South Fork of Putah Creek	Existing: municipal and domestic supply (MUN); agricultural supply (AGR), irrigation and stock watering; water contact recreation (REC-1), contact, and canoeing and rafting; non-contact water recreation (REC-2), warm freshwater habitat (WARM); wildlife habitat (WILD); and spawning, reproduction, and/or early development (SPWN), warm. Potential: cold freshwater habitat (COLD).
--	Groundwater	Suitable or Potentially Suitable: municipal and domestic supply (MUN); agricultural supply (AGR), irrigation and stock watering; industrial service supply (IND); and industrial process supply (PRO).

2. **National Toxics Rule (NTR) and California Toxics Rule (CTR).** U.S. EPA adopted the NTR on 22 December 1992, and later amended it on 4 May 1995 and 9 November 1999. About forty criteria in the NTR applied in California. On 18 May 2000, U.S. EPA adopted the CTR. The CTR promulgated new toxics criteria for California and, in addition, incorporated the previously adopted NTR criteria that were applicable in the state. The CTR was amended on 13 February 2001. These rules contain federal water quality criteria for priority pollutants.
3. **State Implementation Policy.** On 2 March 2000, the State Water Board adopted the Policy for Implementation of Toxics Standards for Inland Surface

Waters, Enclosed Bays, and Estuaries of California (State Implementation Policy or SIP). The SIP became effective on 28 April 2000, with respect to the priority pollutant criteria promulgated for California by the U.S. EPA through the NTR and to the priority pollutant objectives established by the Central Valley Water Board in the Basin Plan. The SIP became effective on 18 May 2000, with respect to the priority pollutant criteria promulgated by the U.S. EPA through the CTR. The State Water Board adopted amendments to the SIP on 24 February 2005, that became effective on 13 July 2005. The SIP establishes implementation provisions for priority pollutant criteria and objectives and provisions for chronic toxicity control. Requirements of this Order implement the SIP.

4. **Antidegradation Policy.** Federal regulation 40 C.F.R. section 131.12 requires that the state water quality standards include an antidegradation policy consistent with the federal policy. The State Water Board established California's antidegradation policy in State Water Board Resolution 68-16 ("Statement of Policy with Respect to Maintaining High Quality of Waters in California") (State Anti-Degradation Policy). The State Anti-Degradation Policy is deemed to incorporate the federal antidegradation policy where the federal policy applies under federal law. The State Anti-Degradation Policy requires that existing water quality be maintained unless degradation is justified based on specific findings. The Central Valley Water Board's Basin Plan implements, and incorporates by reference, both the State and federal antidegradation policies. The permitted discharge must be consistent with the antidegradation provision of 40 C.F.R. section 131.12 and the State Anti-Degradation Policy. The Board finds this order is consistent with the Federal and State Water Board antidegradation regulations and policy.
5. **Anti-Backsliding Requirements.** Sections 402(o) and 303(d)(4) of the CWA and federal regulations at 40 C.F.R. section 122.44(l) restrict backsliding in NPDES permits. These anti-backsliding provisions require that effluent limitations in a reissued permit must be as stringent as those in the previous permit, with some exceptions in which limitations may be relaxed.
6. **Domestic Water Quality.** In compliance with Water Code section 106.3, it is the policy of the State of California that every human being has the right to safe, clean, affordable, and accessible water adequate for human consumption, cooking, and sanitary purposes. This Order promotes that policy by requiring discharges to meet maximum contaminant levels designed to protect human health and ensure that water is safe for domestic use.
7. **Endangered Species Act Requirements.** This Order does not authorize any act that results in the taking of a threatened or endangered species or any act that is now prohibited, or becomes prohibited in the future, under either the California Endangered Species Act (Fish and Game Code, sections 2050 to 2097) or the Federal Endangered Species Act (16 U.S.C.A. sections 1531 to 1544). This Order requires compliance with effluent limits, receiving water

limits, and other requirements to protect the beneficial uses of waters of the state. The Discharger is responsible for meeting all requirements of the applicable Endangered Species Act.

8. **Emergency Planning and Community Right to Know Act.** Section 13263.6(a) of the Water Code, requires that “the Regional Water Board shall prescribe effluent limitations as part of the waste discharge requirements of a POTW for all substances that the most recent toxic chemical release data reported to the state emergency response commission pursuant to section 313 of the Emergency Planning and Community Right to Know Act of 1986 (42 U.S.C. Sec. 11023) (EPCRA) indicate as discharged into the POTW, for which the State Water Board or the Regional Water Board has established numeric water quality objectives, and has determined that the discharge is or may be discharged at a level which will cause, have the reasonable potential to cause, or contribute to, an excursion above any numeric water quality objective”.

The most recent toxic chemical data report does not indicate any reportable off-site releases or discharges to the collection system for this Facility. Therefore, a reasonable potential analysis based on information from EPCRA cannot be conducted. Based on information from EPCRA, there is no reasonable potential to cause or contribute to an excursion above any numeric water quality objectives included within the Basin Plan or in any State Water Board plan, so no effluent limitations are included in this permit pursuant to Water Code section 13263.6(a).

However, as detailed elsewhere in this Order, available effluent data indicate that there are constituents present in the effluent that have a reasonable potential to cause or contribute to exceedances of water quality standards and require inclusion of effluent limitations based on federal and state laws and regulations.

9. **Storm Water Requirements.** U.S. EPA promulgated federal regulations for storm water on 16 November 1990 in 40 C.F.R. parts 122, 123, and 124. The NPDES Industrial Storm Water Program regulates storm water discharges from wastewater treatment facilities. Wastewater treatment plants are applicable industries under the storm water program and are obligated to comply with the federal regulations. The State Water Resources Control Board Water Quality Order 2014-0057-DWQ, General Permit for Storm Water Discharges Associated with Industrial Activities (NPDES General Permit No. CAS000001), does not require facilities to obtain coverage if discharges of storm water are regulated under another individual or general NPDES permit adopted by the State Water Board or Regional Water Board (Finding I.B.20). All storm water at the Facility is captured and directed to the Facility headworks for treatment and disposal under this Order. Therefore, coverage under the General Storm Water Permit is not required. The Discharger is covered by the State Water Board Water Quality Order 2013-0001, NPDES General Permit No. CAS000004, Waste Discharge Requirements for Discharges from Small Municipal Separate Storm Sewer Systems.

10. **Statewide General Waste Discharge Requirements for Sanitary Sewer Systems.** The State Water Board issued General Waste Discharge Requirements for Sanitary Sewer Systems, Water Quality Order 2006-0003-DWQ (General Order) on 2 May 2006. The State Water Board amended the Monitoring and Reporting Program (MRP) for the General Order through Order WQ 2013-0058-EXEC on 6 August 2013. The General Order requires public agencies that own or operate sanitary sewer systems with greater than 1 mile of pipes or sewer lines to enroll for coverage under the General Order. The General Order requires agencies to develop sanitary sewer management plans (SSMP's) and report all sanitary sewer overflows (SSO's), among other requirements and prohibitions.

The Discharger is subject to the requirements of, and must comply with, State Water Board Order 2006-0003-DWQ, Statewide General Waste Discharge Requirements for Sanitary Sewer Systems, as amended by State Water Board Order WQ 2013-0058-EXEC and any subsequent order.

11. **Sewage Sludge and Biosolids.** This Order does not authorize any act that results in violation of requirements administered by U.S. EPA to implement 40 C.F.R. Part 503, Standards for the Use or Disposal of Sewage Sludge. These standards regulate the final use or disposal of sewage sludge that is generated during the treatment of domestic sewage in a municipal wastewater treatment facility. The Discharger is responsible for meeting all applicable requirements of 40 C.F.R. Part 503 that are under U.S. EPA's enforcement authority.

#### **D. Impaired Water Bodies on CWA 303(d) List**

1. Under section 303(d) of the 1972 CWA, states, territories, and authorized tribes are required to develop lists of water quality limited segments. The waters on these lists do not meet water quality standards, even after point sources of pollution have installed the minimum required levels of pollution control technology. On 6 April 2018 U.S. EPA gave final approval to California's 2014-2016 section 303(d) List of Water Quality Limited Segments. The Basin Plan references this list of Water Quality Limited Segments (WQLSs), which are defined as "...those sections of lakes, streams, rivers or other fresh water bodies where water quality does not meet (or is not expected to meet) water quality standards even after the application of appropriate limitations for point sources (40 C.F.R. part 130, et seq.)." The Basin Plan also states, "Additional treatment beyond minimum federal standards will be imposed on dischargers to [WQLSs]. Dischargers will be assigned or allocated a maximum allowable load of critical pollutants so that water quality objectives can be met in the segment." The listing for Putah Creek includes mercury.
2. **Total Maximum Daily Loads (TMDLs).** Table F-4, below, identifies the 303(d) listings and any applicable TMDLs. At the time of this permit renewal, there are no approved TMDLs with waste load allocations that apply to this Facility.

**Table F-4. 303 (d) List for Putah Creek**

<b>Pollutant</b>	<b>Potential Sources</b>	<b>TMDL Status</b>
Mercury	Resource Extraction, Source Unknown	Under Development

3. The 303(d) listings and TMDLs have been considered in the development of the Order. A pollutant-by-pollutant evaluation of each pollutant of concern is described in section IV.C.3 of this Fact Sheet.

**E. Other Plans, Policies and Regulations**

1. **Title 27.** The discharge authorized herein and the treatment and storage facilities associated with the discharge of treated municipal wastewater, except for discharges of residual sludge and solid waste, are exempt from the requirements of Title 27, California Code of Regulations (CCR), section 20005 et seq (hereafter Title 27). The exemption, pursuant to Title 27 CCR section 20090(a), is based on the following:
  - a. The waste consists primarily of domestic sewage and treated effluent;
  - b. The waste discharge requirements are consistent with water quality objectives; and
  - c. The treatment and storage facilities described herein are associated with a municipal wastewater treatment plant.

**IV. RATIONALE FOR EFFLUENT LIMITATIONS AND DISCHARGE SPECIFICATIONS**

Effluent limitations and toxic and pretreatment effluent standards established pursuant to sections 301 (Effluent Limitations), 302 (Water Quality Related Effluent Limitations), 304 (Information and Guidelines), and 307 (Toxic and Pretreatment Effluent Standards) of the CWA and amendments thereto are applicable to the discharge.

The CWA mandates the implementation of effluent limitations that are as stringent as necessary to meet water quality standards established pursuant to state or federal law [33 U.S.C., section 1311(b)(1)(C); 40 C.F.R. section 122.44(d)(1)]. NPDES permits must incorporate discharge limits necessary to ensure that water quality standards are met. This requirement applies to narrative criteria as well as to criteria specifying maximum amounts of particular pollutants. Pursuant to federal regulations, 40 C.F.R. section 122.44(d)(1)(i), NPDES permits must contain limits that control all pollutants that “are or may be discharged at a level which will cause, have the reasonable potential to cause, or contribute to an excursion above any state water quality standard, including state narrative criteria for water quality.” Federal regulations, 40 C.F.R. section 122.44(d)(1)(vi), further provide that “[w]here a state has not established a water quality criterion for a specific chemical pollutant that is present in an effluent at a concentration that causes, has the reasonable potential to cause, or contributes to an excursion above a narrative criterion within an applicable State water quality standard, the permitting authority must establish effluent limits.”



The CWA requires point source dischargers to control the amount of conventional, non-conventional, and toxic pollutants that are discharged into the waters of the United States. The control of pollutants discharged is established through effluent limitations and other requirements in NPDES permits. There are two principal bases for effluent limitations in the Code of Federal Regulations: 40 C.F.R. section 122.44(a) requires that permits include applicable technology-based limitations and standards; and 40 C.F.R. section 122.44(d) requires that permits include water quality based effluent limitations (WQBELs) to attain and maintain applicable numeric and narrative water quality criteria to protect the beneficial uses of the receiving water where numeric water quality objectives have not been established. The Basin Plan at page 4-27, contains an implementation policy, "Policy for Application of Water Quality Objectives", that specifies that the Central Valley Water Board "will, on a case-by-case basis, adopt numerical limitations in orders which will implement the narrative objectives." This Policy complies with 40 C.F.R. section 122.44(d)(1). With respect to narrative objectives, the Central Valley Water Board must establish effluent limitations using one or more of three specified sources, including: (1) U.S. EPA's published water quality criteria, (2) a proposed state criterion (i.e., water quality objective) or an explicit state policy interpreting its narrative water quality criteria (i.e., the Central Valley Water Board's "Policy for Application of Water Quality Objectives")(40 C.F.R. section 122.44(d)(1)(vi)(A), (B) or (C)), or (3) an indicator parameter.

The Basin Plan includes numeric site-specific water quality objectives and narrative objectives for toxicity, chemical constituents, discoloration, radionuclides, and tastes and odors. The narrative toxicity objective states: "All waters shall be maintained free of toxic substances in concentrations that produce detrimental physiological responses in human, plant, animal, or aquatic life." (Basin Plan at section 3.1.20) The Basin Plan states that material and relevant information, including numeric criteria, and recommendations from other agencies and scientific literature will be utilized in evaluating compliance with the narrative toxicity objective. The narrative chemical constituents' objective states that waters shall not contain chemical constituents in concentrations that adversely affect beneficial uses. At minimum, "...water designated for use as domestic or municipal supply (MUN) shall not contain concentrations of chemical constituents in excess of the maximum contaminant levels (MCLs)" in Title 22 of CCR. The Basin Plan further states that, to protect all beneficial uses, the Central Valley Water Board may apply limits more stringent than MCLs. The narrative tastes and odors objective states: "Water shall not contain taste- or odor-producing substances in concentrations that impart undesirable tastes or odors to domestic or municipal water supplies or to fish flesh or other edible products of aquatic origin, or that cause nuisance, or otherwise adversely affect beneficial uses."

#### **A. Discharge Prohibitions**

- 1. Prohibition III.A (No discharge or application of waste other than that described in this Order).** This prohibition is based on Water Code section 13260 that requires filing of a ROWD before discharges can occur. The Discharger submitted a Notice of Intent application requesting coverage under the MGO R5-2017-0085. The Notice of Intent fulfills the filing requirements of

the ROWD for the discharges described in this Order; therefore, discharges not described in this Order are prohibited.

2. **Prohibition III.B (No bypasses or overflow of untreated wastewater, except under the conditions at CFR section 122.41(m)(4)).** As stated in section I.G of Attachment D, Standard Provisions, this Order prohibits bypass from any portion of the treatment facility. Federal regulations, 40 C.F.R. section 122.41(m), define “bypass” as the intentional diversion of waste streams from any portion of a treatment facility. This section of the federal regulations, 40 C.F.R. section 122.41(m)(4), prohibits bypass unless it is unavoidable to prevent loss of life, personal injury, or severe property damage. In considering the Regional Water Board’s prohibition of bypasses, the State Water Board adopted a precedential decision, Order No. WQO 2002-0015, which cites the federal regulations, 40 C.F.R. section 122.41(m), as allowing bypass only for essential maintenance to assure efficient operation.
3. **Prohibition III.C (No controllable condition shall create a nuisance).** This prohibition is based on Water Code section 13050 that requires water quality objectives established for the prevention of nuisance within a specific area. The Basin Plan prohibits conditions that create a nuisance
4. **Prohibition III.D (No discharge of hazardous waste).** This prohibition is based on California Code of Regulations, title 22, section 66261.1 et seq, that prohibits discharge of hazardous waste.
5. **Prohibition III.E (Average Dry Weather Flow).** This prohibition is based on the design average dry weather flow treatment capacity rating for the Facility and ensures the Facility is operated within its treatment capacity. Previous Order R5-2014-0152 included flow as an effluent limit based on the Facility design flow. Flow is not a pollutant and therefore has been changed from an effluent limit to a discharge prohibition in this Order, which is an equivalent level of regulation. This Order is not less stringent because compliance with flow as a discharge prohibition will be calculated the same way as the previous Order.

## **B. Technology-Based Effluent Limitations**

### **1. Scope and Authority**

Section 301(b) of the CWA and implementing U.S. EPA permit regulations at 40 C.F.R. section 122.44 require that permits include conditions meeting applicable technology-based requirements at a minimum, and any more stringent effluent limitations necessary to meet applicable water quality standards. The discharge authorized by this Order must meet minimum federal technology-based requirements based on Secondary Treatment Standards at 40 C.F.R. part 133.

Regulations promulgated in 40 C.F.R. section 125.3(a)(1) require technology-based effluent limitations for municipal Dischargers to be placed in NPDES

permits based on Secondary Treatment Standards or Equivalent to Secondary Treatment Standards.

The Federal Water Pollution Control Act Amendments of 1972 (PL 92-500) established the minimum performance requirements for POTWs [defined in section 304(d)(1)]. Section 301(b)(1)(B) of that Act requires that such treatment works must, as a minimum, meet effluent limitations based on secondary treatment as defined by the U.S. EPA Administrator.

Based on this statutory requirement, U.S. EPA developed secondary treatment regulations, which are specified in 40 C.F.R. part 133. These technology-based regulations apply to all municipal wastewater treatment plants and identify the minimum level of effluent quality attainable by secondary treatment in terms of BOD<sub>5</sub>, TSS, and pH.

**2. Applicable Technology-Based Effluent Limitations**

- a. **BOD<sub>5</sub> and TSS.** Federal regulations at 40 C.F.R. part 133, establish the minimum weekly and monthly average level of effluent quality attainable by secondary treatment for BOD<sub>5</sub> and TSS. A daily maximum effluent limitation for BOD<sub>5</sub> and TSS is also included in the Order to ensure that the treatment works are not organically overloaded and operate in accordance with design capabilities. In addition, 40 C.F.R. section 133.102, in describing the minimum level of effluent quality attainable by secondary treatment, states that the 30-day average percent removal shall not be less than 85 percent. This Order contains a limitation requiring an average of 85 percent removal of BOD<sub>5</sub> and TSS over each calendar month. This Order requires WQBELs that are equal to or more stringent than the secondary technology-based treatment described in 40 CFR part 133 (see section IV.C.3.c of this Fact Sheet for a discussion on Pathogens which includes WQBELs for BOD<sub>5</sub> and TSS.).
- b. **pH.** The secondary treatment regulations at 40 C.F.R. part 133 also require that pH be maintained between 6.0 and 9.0 standard units. This Order, however, requires more stringent WQBELs for pH to comply with the Basin Plan’s water quality objectives for pH.

**Summary of Technology-based Effluent Limitations  
 Discharge Points 001 and 002**

**Table F-5. Summary of Technology-based Effluent Limitations**

Parameter	Units	Effluent Limitations
BOD <sub>5</sub>	mg/L	AMEL 30 AWEL 45
BOD <sub>5</sub>	% removal	Average Monthly greater than or equal to 85

Parameter	Units	Effluent Limitations
TSS	mg/L	AMEL 30 AWEL 45
TSS	% removal	Average Monthly greater than or equal to 85
pH	standard units	Instantaneous Min 6.0 Instantaneous Max 9.0

**Table F-5 Note:**

- Note that more stringent WQBELs for **BOD<sub>5</sub>, pH, and TSS** are applicable and are established as final effluent limitations in this Order (see section IV.C.3.c of this Fact Sheet).

**C. Water Quality-Based Effluent Limitations (WQBELs)**

**1. Scope and Authority**

CWA section 301(b) and 40 C.F.R. section 122.44(d) require that permits include limitations more stringent than applicable federal technology-based requirements where necessary to achieve applicable water quality standards. This Order contains requirements, expressed as a technology equivalence requirement, more stringent than secondary treatment requirements that are necessary to meet applicable water quality standards. The rationale for these requirements, which consist of tertiary treatment or equivalent requirements or other provisions, is discussed in section IV.C.3.b in this Fact Sheet.

Section 122.44(d)(1)(i) of 40 C.F.R. requires that permits include effluent limitations for all pollutants that are or may be discharged at levels that have the reasonable potential to cause or contribute to an exceedance of a water quality standard, including numeric and narrative objectives within a standard. Where reasonable potential has been established for a pollutant, but there is no numeric criterion or objective for the pollutant, WQBELs must be established using: (1) U.S. EPA criteria guidance under CWA section 304(a), supplemented where necessary by other relevant information; (2) an indicator parameter for the pollutant of concern; or (3) a calculated numeric water quality criterion, such as a proposed state criterion or policy interpreting the state’s narrative criterion, supplemented with other relevant information, as provided in section 122.44(d)(1)(vi).

The process for determining reasonable potential and calculating WQBELs when necessary is intended to protect the designated uses of the receiving water as specified in the Basin Plan, and achieve applicable water quality objectives and criteria that are contained in other state plans and policies, or any applicable water quality criteria contained in the CTR and NTR.

Finally, 40 C.F.R. section 122(d)(1)(vii) requires effluent limits to be developed consistent with any available waste load allocations developed and approved for the discharge.

## 2. **Applicable Beneficial Uses and Water Quality Criteria and Objectives**

The Basin Plan designates beneficial uses, establishes water quality objectives, and contains implementation programs and policies to achieve those objectives for all waters addressed through the plan. In addition, the Basin Plan implements State Water Board Resolution No. 88-63, which established state policy that all waters, with certain exceptions, should be considered suitable or potentially suitable for municipal or domestic supply.

The Basin Plan on page II-1.00 states: "Protection and enhancement of existing and potential beneficial uses are primary goals of water quality planning..." and with respect to disposal of wastewaters states that "...disposal of wastewaters is [not] a prohibited use of waters of the State; it is merely a use which cannot be satisfied to the detriment of beneficial uses."

The federal CWA section 101(a)(2), states: "it is the national goal that wherever attainable, an interim goal of water quality which provides for the protection and propagation of fish, shellfish, and wildlife, and for recreation in and on the water be achieved by July 1, 1983." Federal Regulations, developed to implement the requirements of the CWA, create a rebuttable presumption that all waters be designated as fishable and swimmable. Federal Regulations, 40 CFR sections 131.2 and 131.10, require that all waters of the State regulated to protect the beneficial uses of public water supply, protection and propagation of fish, shellfish and wildlife, recreation in and on the water, agricultural, industrial and other purposes including navigation. 40 C.F.R. section 131.3(e) defines existing beneficial uses as those uses actually attained after 28 November 1975, whether or not they are included in the water quality standards. Federal Regulation, 40 C.F.R. section 131.10 requires that uses be obtained by implementing effluent limitations, requires that all downstream uses be protected and states that in no case shall a state adopt waste transport or waste assimilation as a beneficial use for any waters of the United States.

- a. **Receiving Water and Beneficial Uses.** Refer to III.C.1. above for a complete description of the receiving water and beneficial uses.
- b. **Effluent and Ambient Background Data.** The reasonable potential analysis (RPA), as described in section IV.C.3 of this Fact Sheet, was based on data from August 2016 through September 2019, which includes effluent and ambient background data submitted in SMRs.
- c. **Assimilative Capacity/Mixing Zone.** Based on the available information, the worst-case dilution is assumed to be zero to provide protection for the receiving water beneficial uses. The impact of assuming zero assimilative capacity within the receiving water is that discharge limitations are end-of-pipe limits with no allowance for dilution within the receiving water.

- d. **Conversion Factors.** The CTR contains aquatic life criteria for arsenic, cadmium, chromium III, chromium VI, copper, lead, nickel, silver, and zinc which are presented in dissolved concentrations. U.S. EPA recommends conversion factors to translate dissolved concentrations to total concentrations. The default U.S. EPA conversion factors contained in Appendix 3 of the SIP were used to convert the applicable dissolved criteria to total recoverable criteria.
- e. **Hardness-Dependent CTR Metals Criteria.** The CTR and the NTR contain water quality criteria for seven metals that vary as a function of hardness. The lower the hardness the lower the water quality criteria. The metals with hardness-dependent criteria include cadmium, copper, chromium III, lead, nickel, silver, and zinc.

This Order has established the criteria for hardness-dependent metals based on the hardness of the receiving water (actual ambient hardness) as required by the SIP<sup>1</sup> and the CTR<sup>2</sup>. The SIP and the CTR require the use of “receiving water” or “actual ambient” hardness, respectively, to determine effluent limitations for these metals. The CTR requires that the hardness values used shall be consistent with the design discharge conditions for design flows and mixing zones (40 C.F.R. section 131.3(c)(4)(ii)). Where design flows for aquatic life criteria include the lowest one-day flow with an average reoccurrence frequency of once in ten years (1Q10) and the lowest average seven consecutive day flow with an average reoccurrence frequency of once in ten years (7Q10).<sup>3</sup> This section of the CTR also indicates that the design conditions should be established such that the appropriate criteria are not exceeded more than once in a three year period on average.<sup>4</sup> The CTR requires that when mixing zones are allowed the CTR criteria apply at the edge of the mixing zone, otherwise the criteria apply throughout the water body including at the point of discharge.<sup>5</sup> The CTR does not define the term “ambient,” as applied in the regulations. Therefore, the Central Valley Water Board has considerable discretion to consider upstream and downstream ambient conditions when establishing the appropriate water quality criteria that fully complies with the CTR and SIP.

**Summary findings.**

The ambient hardness for the South Fork of Putah Creek is represented

---

<sup>1</sup> The SIP does not address how to determine the hardness for application to the equations for the protection of aquatic life when using hardness-dependent metals criteria. It simply states, in section 1.2, that the criteria shall be properly adjusted for hardness using the hardness of the receiving water.

<sup>2</sup> The CTR requires that, for waters with a hardness of 400 mg/L (as CaCO<sub>3</sub>), or less, the actual ambient hardness of the surface water must be used (40 C.F.R. section 131.38(c)(4)).

<sup>3</sup> 40 C.F.R. section 131.38(c)(2)(iii) Table 4

<sup>4</sup> 40 C.F.R. section 131.38(c)(2)(iii) Table 4, notes 1 and 2

<sup>5</sup> 40 C.F.R. section 131.38(c)(2)(i)

by the data in Figure F-1, below, which shows ambient hardness ranging from 96 mg/L to 210 mg/L based on collected ambient data from August 2016 through September 2019. Given the high variability in ambient hardness values, there is no single hardness value that describes the ambient receiving water for all possible scenarios (e.g., minimum, maximum). Because of this variability, staff has determined that based on the ambient hardness concentrations measured in the receiving water, the Central Valley Water Board has discretion to select ambient hardness values within the range of 96 mg/L (minimum) up to 210 mg/L (maximum). Staff recommends that the Board use the ambient hardness values shown in Table F-6 for the following reasons:

- i. Using the ambient receiving water hardness values shown in Table F-6 will result in criteria and effluent limitations that ensure protection of beneficial uses under all ambient receiving water conditions.
- ii. The Water Code mandates that the Central Valley Water Board establish permit terms that will ensure the reasonable protection of beneficial uses. In this case, using the lowest measured ambient hardness to calculate effluent limitations is not required to protect beneficial uses. Calculating effluent limitations based on the lowest measured ambient hardness is not required by the CTR or SIP and is not reasonable as it would result in overly conservative limits that will impart substantial costs to the Discharger and ratepayers without providing any additional protection of beneficial uses. In compliance with applicable state and federal regulatory requirements, after considering the entire range of ambient hardness values, Board staff has used the ambient hardness values shown in Table F-6 to calculate the proposed effluent limitations for hardness-dependent metals. The proposed effluent limitations are protective of beneficial uses under all flow conditions.
- iii. Using an ambient hardness that is higher than the minimum of 96 mg/L will result in limits that may allow increased metals to be discharged to the river, but such discharge is allowed under the State Antidegradation Policy (State Water Board Resolution 68-16). The Central Valley Water Board finds that this degradation is consistent with the antidegradation policy (see antidegradation findings in section IV.D.4 of this Fact Sheet). The Antidegradation policy requires the Discharger to meet waste discharge requirements which will result in the best practicable treatment or control of the discharge necessary to assure that: a) a pollution or nuisance will not occur, and b) the highest water quality consistent with maximum benefit to the people of the State will be maintained.
- iv. Using the ambient hardness values shown in Table F-6 is consistent with the CTR and SIP's requirements for developing metals criteria.

**Table F-6. Summary of CTR Criteria for Hardness-dependent Metals**

<b>CTR Metals</b>	<b>Ambient Hardness (mg/L)</b>	<b>CTR Criteria (µg/L, total recoverable) (Acute)</b>	<b>CTR Criteria (µg/L, total recoverable) (Chronic)</b>
Copper	120	17	11
Chromium III	120	2100	250
Cadmium	120 (acute) 120 (chronic)	5.6	2.8
Lead	120	110	4.1
Nickel	120	550	61
Silver	120	5.6	--
Zinc	120	140	140

**Table F-6 Notes:**

1. **CTR Criteria (ug/L total recoverable).** Acute and chronic numbers were rounded to two significant figures in accordance with the CTR (40 C.F.R. section 131.38(b)(2)).
2. **Ambient hardness (mg/L).** Values in Table F-7 represent actual observed receiving water hardness measurements from the dataset shown in Figure F-1.
3. **The CTR’s hardness dependent metals criteria** equations vary differently depending on the metal, which results in differences in the range of ambient hardness values that may be used to develop effluent limitations that are protective of beneficial uses and comply with CTR criteria for all ambient flow conditions.

**Background.**

The State Water Board provided direction regarding the selection of hardness in two precedential water quality orders; WQO 2008-0008 for the City of Davis Wastewater Treatment Plant (Davis Order) and WQO 2004-0013 for the Yuba City Wastewater Treatment Plant (Yuba City Order). The State Water Board recognized that the SIP and the CTR do not discuss the manner in which hardness is to be ascertained, thus regional water boards have considerable discretion in determining ambient hardness so long as the selected value is protective of water quality criteria under the given flow conditions. (Davis Order, p.10). The State Water Board explained that it is necessary that, “The [hardness] value selected should provide protection for all times of discharge under varying hardness conditions.” (Yuba City Order, p. 8). The Davis Order also provides that, “Regardless of the hardness used, the resulting limits must always be protective of water quality criteria under all flow conditions.” (Davis Order, p. 11)

For this discussion, all hardness values are expressed in mg/L as CaCO<sub>3</sub>. The equation describing the total recoverable regulatory criterion, as established in the CTR, is as follows:



$$\text{CTR Criterion} = \text{WER} \times (e^{m[\ln(H)]+b}) \text{ (Equation 1)}$$

Where:

H = ambient hardness (as CaCO<sub>3</sub>)

WER = water-effect ratio

m, b = metal- and criterion-specific constants

The direction in the CTR regarding hardness selection is that it must be based on ambient hardness and consistent with design discharge conditions for design flows and mixing zones. Consistent with design discharge conditions and design flows means that the selected “design” hardness must result in effluent limitations under design discharge conditions that do not result in more than one exceedance of the applicable criteria in a three year period.<sup>6</sup> Where design flows for aquatic life criteria include the lowest one-day flow with an average reoccurrence frequency of once in ten years (1Q10) and the lowest average seven consecutive day flow with an average reoccurrence frequency of once in ten years (7Q10). The 1Q10 and 7Q10 South Fork of Putah Creek flows are 2.2 cfs and 5.3 cfs, respectively.

**Ambient conditions.**

The ambient receiving water hardness varied from 96 mg/L to 210 mg/L, based on 42 samples from August 2016 through September 2019 (see Figure F-1 below).

**Figure F-1. Observed Ambient Hardness Concentrations 2016-2019**

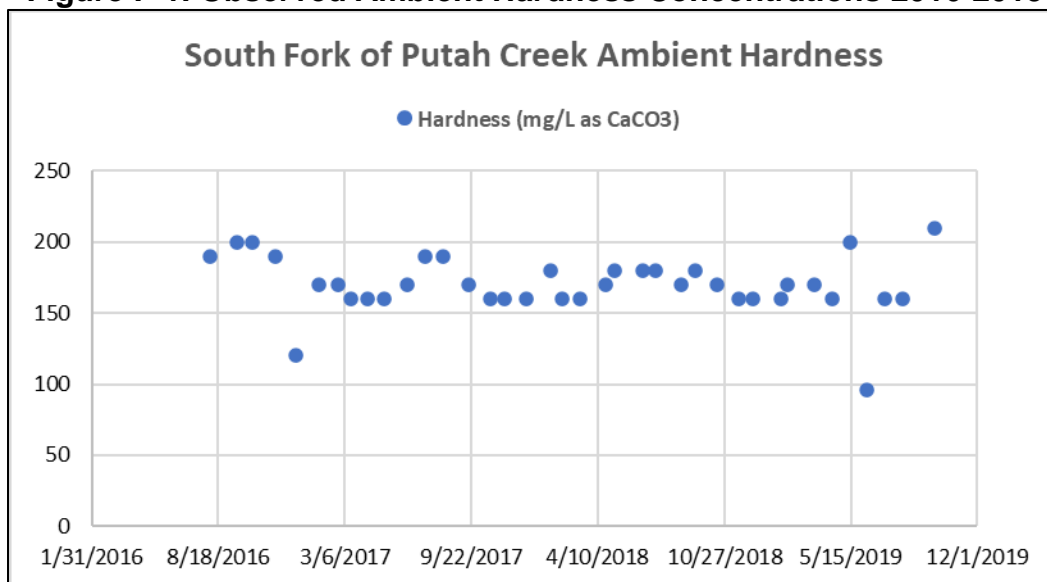

<sup>6</sup> 40 C.F.R. section 131.38(c)(2)(iii) Table 4, notes 1 and 2

In this analysis, the entire range of ambient hardness concentrations shown in Figure F-1 were considered to determine the appropriate ambient hardness to calculate the CTR criteria and effluent limitations that are protective under all discharge conditions.

**Approach to derivation of criteria.**

As shown above, ambient hardness varies substantially. Because of the variation, there is no single hardness value that describes the ambient receiving water for all possible scenarios (e.g., minimum, maximum, mid-point). While the hardness selected must be hardness of the ambient receiving water, selection of an ambient receiving water hardness that is too high would result in effluent limitations that do not protect beneficial uses. Also, the use of minimum ambient hardness would result in criteria that are protective of beneficial uses, but such criteria may not be representative considering the wide range of ambient conditions.

**Reasonable worst-case ambient conditions.**

To determine whether a selected ambient hardness value results in effluent limitations that are fully protective while complying with federal regulations and state policy, staff have conducted an analysis considering varying ambient hardness and flow conditions. To do this, the Central Valley Water Board has ensured that the receiving water hardness and criteria selected for effluent limitations are protective under “reasonable-worst case ambient conditions.” These conditions represent the receiving water conditions under which derived effluent limitations would ensure protection of beneficial uses under all ambient flow and hardness conditions.

Reasonable worst-case ambient conditions:

- “Low receiving water flow.” CTR design discharge conditions (1Q10 and 7Q10) have been selected to represent reasonable worst-case receiving water flow conditions.
- “High receiving water flow (maximum receiving water flow).” This additional flow condition has been selected consistent with the Davis Order, which required that the hardness selected be protective of water quality criteria under all flow conditions.
- “Low receiving water hardness.” The minimum receiving water hardness condition of 96 mg/L was selected to represent the reasonable worst-case receiving water hardness.
- “Background ambient metal concentration at criteria.” This condition assumes that the metal concentration in the background receiving water is equal to CTR criteria (upstream of the Facility’s discharge). Based on data in the record, this is a design condition that has not occurred in the receiving water and is used in this analysis to ensure that limits are

protective of beneficial uses even in the situation where there is no assimilative capacity.

**Iterative approach.**

An iterative analysis has been used to select the ambient hardness to calculate the criteria that will result in effluent limitations that protect beneficial uses under all flow conditions.

The iterative approach is summarized in the following algorithm and described below in more detail.

**Figure F-2. Criteria Calculation CTR**

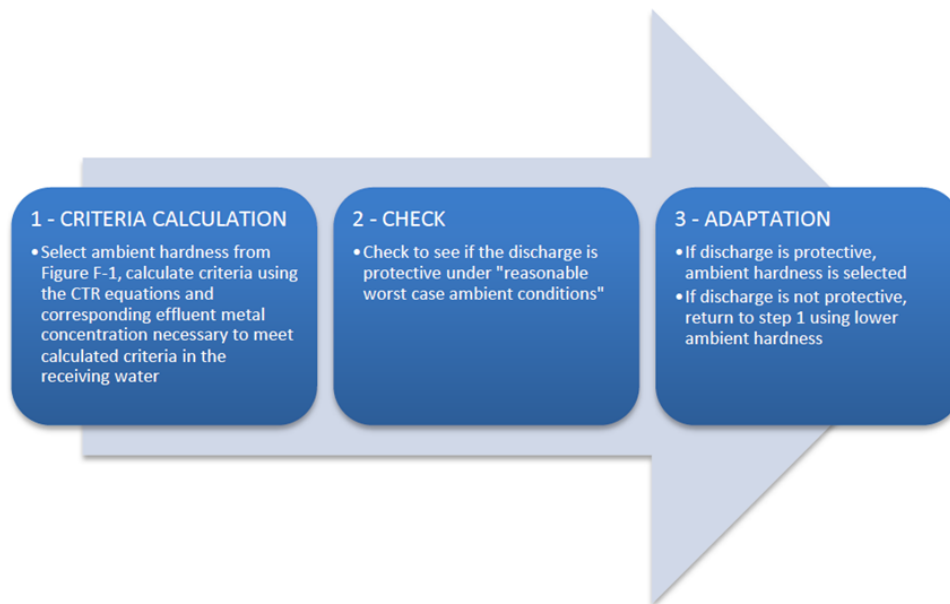

1. **CRITERIA CALCULATION.** CTR criteria are calculated using the CTR equations based on actual measured ambient hardness sample results, starting with the maximum observed ambient hardness of 210 mg/L. Effluent metal concentrations necessary to meet the above calculated CTR criteria in the receiving water are calculated in accordance with the SIP.<sup>7</sup> This should not be confused with an effluent limit. Rather, it is the Effluent Concentration Allowance (ECA), which is synonymous with the waste load allocation defined by U.S. EPA as “a definition of effluent water quality that is necessary to meet the water quality standards in the receiving water.”<sup>8</sup> If effluent limits are found to be needed, the limits are calculated to enforce the ECA considering effluent variability and the probability basis of the limit.

<sup>7</sup> SIP section 1.4.B, Step 2, provides direction for calculating the Effluent Concentration Allowance.

<sup>8</sup> U.S. EPA Technical Support Document for Water Quality-based Toxics Control (TSD), pg. 96.

2. CHECK. U.S. EPA's simple mass balance equation<sup>9</sup> is used to evaluate if discharge at the computed ECA is protective. Resultant downstream metal concentrations are compared with downstream calculated CTR criteria under reasonable worst-case ambient conditions.
3. ADAPT. If step 2 results in:
  - (A) receiving water metal concentration that complies with CTR criteria under reasonable worst-case ambient conditions, then the hardness value is selected.
  - (B) receiving water metal concentration greater than CTR criteria, then return to bullet 1, selecting a lower ambient hardness value.

The CTR's hardness dependent metals criteria equations contain metal-specific constants, so the criteria vary depending on the metal. Therefore, steps 1 through 3 above must be repeated separately for each metal until ambient hardness values are determined that will result in criteria and effluent limitations that comply with the CTR and protect beneficial uses for all metals.

#### **Results of iterative analysis.**

The iterative analysis for each CTR hardness-dependent metal results in the selected ambient hardness values are shown in Table F-6, above. Using these actual receiving water sample hardness values to calculate criteria will result in effluent limitations that are protective under all ambient flow conditions. Ambient hardness values are used in the CTR equations to derive criteria and effluent limitations. As an example of the three-step iterative process, Table F-7 below summarizes the numeric results for copper based on an ambient hardness of 96 mg/L and a calculated ECA of 11 µg/L. Table F-8 below summarizes the numeric results for silver based on an ambient hardness of 96 mg/L and a calculated ECA of 5.6 µg/L. The analysis evaluated all flow conditions, and the numeric values for the critical flow conditions are summarized in Tables F-8 and F-9, below. Ambient concentrations for copper and silver are calculated using the worst-case downstream ambient conditions, which allows for a conservative assumption that will ensure the receiving water complies with CTR criteria. Under the "check" step, worst-case ambient receiving water conditions are used to test whether the effluent discharge results in compliance with CTR criteria and protection of beneficial uses.

The results of the iterative analyses show that the ambient hardness values selected using the three-step iterative process results in protective effluent limitations that achieve CTR criteria under all flow conditions. Tables F-8 and F-9 below, summarize the critical flow conditions. There is

---

<sup>9</sup> U.S. EPA NPDES Permit Writers' Handbook (EPA 833-K-10-001 September 2010, pg. 6-24)

no effluent limitation for copper or silver as it demonstrates no reasonable potential.

**Table F-7. Verification of CTR Compliance for Copper**  
 Downstream Worst-Case Ambient Receiving Water Conditions

Critical Flow Conditions	Hardness (mg/L)	CTR Criteria (µg/L)	Ambient Copper Concentration (µg/L)	Complies with CTR?
1Q10	128	12	11	Yes
7Q10	119	11	10	Yes
Max receiving water flow	96	9.0	9.0	Yes

**Table F-8. Verification of CTR Compliance for Silver**  
 Downstream Worst-Case Ambient Receiving Water Conditions

Critical Flow Conditions	Hardness (mg/L)	CTR Criteria (µg/L)	Ambient Silver Concentration (µg/L)	Complies with CTR?
1Q10	128	6.2	5.1	Yes
7Q10	119	5.4	4.7	Yes
Max receiving water flow	96	3.8	3.8	Yes

**3. Determining the Need for WQBELs**

Clean Water Act section 301(b)(1)(C) requires effluent limitations necessary to meet water quality standards, and 40 C.F.R. section 122.44(d) requires NPDES permits to include conditions that are necessary to achieve water quality standards established under section 303 of the CWA, including State narrative criteria for water quality. Federal regulations at 40 C.F.R. 122.44(d)(1)(i) state, "Limitations must control all pollutants or pollutant parameters (either conventional, nonconventional, or toxic pollutants) which the Director determines are or may be discharged at a level that will cause, have the reasonable potential to cause, or contribute to an excursion above any State water quality standard, including State narrative criteria for water quality." Additionally, 40 C.F.R. section 122(d)(1)(vii) requires effluent limits to be developed consistent with any available waste load allocations developed and approved for the discharge. The process to determine whether a WQBEL is required as described in 40 C.F.R. section 122.44(d)(1)(i) is referred to as a reasonable potential analysis or RPA. Central Valley Water Board staff conducted RPAs for nearly 200 constituents, including the 126 U.S. EPA priority toxic pollutants. This section includes details of the RPAs for constituents of concern for the Facility. The entire RPA is included in the administrative record and a summary of the constituents of concern is provided in Attachment G. For priority pollutants, the SIP dictates the procedures for conducting the RPA. For non-priority pollutants the Central Valley Water Board

is not restricted to one particular RPA method, therefore, the RPAs have been conducted based on EPA guidance considering multiple lines of evidence and the site-specific conditions of the discharge.

- a. **Constituents with No Reasonable Potential.** Central Valley Water Board staff conducted reasonable potential analyses for nearly 200 constituents, including the 126 U.S. EPA priority toxic pollutants. All reasonable potential analyses are included in the administrative record and a summary of the constituents of concern is provided in Attachment G. WQBELs are not included in this Order for constituents that do not demonstrate reasonable potential to cause or contribute to an instream excursion of an applicable water quality objective; however, monitoring for those pollutants is established in this Order as required by the SIP. If the results of effluent monitoring demonstrate reasonable potential, this Order may be reopened and modified by adding an appropriate effluent limitation.

Most constituents with no reasonable potential are not discussed in this Order. This section provides the rationale for the reasonable potential analyses for the following constituents of concern that were found to have no reasonable potential after assessment of the data or that are no longer necessary to protect aquatic life.

- i. **Chlorine Residual**

- (a) **WQO.** U.S. EPA developed NAWQC for protection of freshwater aquatic life for chlorine residual. The recommended 4-day average (chronic) and 1-hour average (acute) criteria for chlorine residual are 0.011 mg/L and 0.019 mg/L, respectively. These criteria are protective of the Basin Plan's narrative toxicity objective.
- (b) **RPA Results.** Order R5-2014-0152 included effluent limitations for total residual chlorine because the Discharger periodically used chlorine for cleaning and maintenance of the cloth disc filter. However, the Discharger no longer uses chlorine at the Facility. Therefore, the discharge no longer has reasonable potential to cause or contribute to an instream excursion above the NAWQC and the effluent limitations have not been retained for total residual chlorine.

- ii. **Mercury**

- (a) **WQO.** The current NAWQC for protection of freshwater aquatic life, continuous concentration, for mercury is 0.77 µg/L (30-day average, chronic criteria). The CTR contains a human health criterion (based on a threshold dose level causing neurological effects in infants) of 0.050 µg/L for waters from which both water and aquatic organisms are consumed. Both values are controversial and subject to change. In 40 C.F.R. part 131, U.S.

EPA acknowledges that the human health criteria may not be protective of some aquatic or endangered species and that "...more stringent mercury limits may be determined and implemented through use of the State's narrative criterion." In the CTR, U.S. EPA reserved the mercury criteria for freshwater and aquatic life and may adopt new criteria at a later date.

The State Water Board adopted Resolution 2017-0027 on 2 May 2017, which approved Part 2 of the Water Quality Control Plan for Inland Surface Waters, Enclosed Bays, and Estuaries of California, Tribal and Subsistence Fishing Beneficial Uses and Mercury Provisions (Statewide Mercury Provisions). The Statewide Mercury Provisions establish a Sport Fish Water Quality Objective of an average 0.2 mg/kg methylmercury fish tissue concentration within a calendar year for waters with the beneficial uses of commercial and sport fishing (COMM), tribal tradition and culture (CUL), wildlife habitat (WILD), and marine habitat (MAR). This fish tissue objective corresponds to a water column concentration of 12 ng/L of total mercury for flowing water bodies (e.g., rivers, creeks, streams, and waters with tidal mixing). As shown in Table F-3, the beneficial uses of the South Fork of Putah Creek include WILD; therefore, the Sport Fish Water Quality Objective is applicable and is the most stringent objective.

- (b) **RPA Results.** The Statewide Mercury Provisions specify that the RPA shall be conducted using the maximum annual average effluent and background mercury concentrations for comparison with the Sport Fish Water Quality Objective. The maximum observed effluent mercury concentration was 0.61 ng/L, with a maximum annual average of 0.61 ng/L, based on six samples collected from November 2016 to December 2018. The maximum annual average background concentration for mercury was non-detect based on four samples collected during 2017.

Therefore, the discharge does not exhibit reasonable potential to cause or contribute to an exceedance of the Sport Fish Water Quality Objective in the receiving water. However, the South Fork of Putah Creek has been listed as an impaired water body pursuant to CWA section 303(d) because of mercury and the discharge must not cause or contribute to increased mercury levels.

- (c) **WQBELs.** This Order contains a performance-based calendar year annual mass effluent limitation of 0.015 lbs/year for mercury for the effluent discharged to the receiving water. This limitation is based on maintaining the mercury loading at the current level until a TMDL can be established. The performance-based mercury effluent mass limit was derived using current, representative data.

- (d) **Plant Performance and Attainability.** As shown above, analysis of the effluent and receiving water data shows that the observed concentrations are less than the applicable Sport Fish Water Quality Objective. The Central Valley Water Board concludes, therefore, that immediate compliance with these effluent limitations is feasible.

iii. **Salinity**

- (a) **WQO.** The Basin Plan contains a chemical constituent objective that incorporates state MCLs, contains a narrative objective, and contains numeric water quality objectives for certain specified water bodies for electrical conductivity, total dissolved solids, sulfate, and chloride. The U.S. EPA Ambient Water Quality Criteria for Chloride recommends acute and chronic criteria for the protection of aquatic life. There are no U.S. EPA water quality criteria for the protection of aquatic life for electrical conductivity, total dissolved solids, and sulfate. Additionally, there are no U.S. EPA numeric water quality criteria for the protection of agricultural, livestock, and industrial uses. Numeric values for the protection of these uses are typically based on site specific conditions and evaluations to determine the appropriate constituent threshold necessary to interpret the narrative chemical constituent Basin Plan objective. The Central Valley Water Board must determine the applicable numeric limit to implement the narrative objective for the protection of agricultural supply. Table F-9, below, contains various recommended levels for EC or TDS, sulfate, and chloride.

**Table F-9. Salinity Water Quality Criteria/Objectives**

Parameters	Secondary MCL Recommended Level.	Secondary MCL Upper Level	Secondary MCL Short-term Maximum	U.S. EPA NAWQC	Maximum Calendar Annual Average Effluent Concentration	Maximum Daily Effluent Concentration
EC (µmhos/cm) or TDS (mg/L)	EC 900 or TDS 500	EC 1,600 or TDS 1,000	EC 2,200 or TDS 1,500	N/A	EC 1091; TDS 664	EC 1698; TDS 833
Sulfate (mg/L)	250	500	600	N/A	54	110
Chloride (mg/L)	250	500	600	860 1-hour; 230 4-day	100	110

**Table F-9 Notes:**



1. **Agricultural Water Quality Objectives.** Applicable agricultural water quality objectives vary and the Basin Plan includes a narrative objective for salinity. Procedures for establishing the applicable numeric limitation to implement the narrative objective can be found in the Policy for Application of Water Quality Objectives, section 4.2.2.1.9 of the Basin Plan. However, the Basin Plan does not require improvement over naturally occurring background concentrations. In cases where the natural background concentration of a particular constituent exceeds an applicable water quality objective, the natural background concentration will be considered to comply with the objective.
2. **Secondary MCLs.** Secondary MCLs are for protection of public welfare and are stated as a recommended level, upper level, and a short-term maximum level.
3. **Chloride.** The Secondary MCL for chloride is 250 mg/L, as a recommended level, 500 mg/L as an upper level, and 600 mg/L as a short-term maximum.
4. **Electrical Conductivity or Total Dissolved Solids.** The Secondary MCL for EC is 900  $\mu\text{mhos/cm}$  as a recommended level, 1600  $\mu\text{mhos/cm}$  as an upper level, and 2200  $\mu\text{mhos/cm}$  as a short-term maximum, or when expressed as TDS is 500 mg/L as a recommended level, 1000 mg/L as an upper level, and 1500 mg/L as a short-term maximum.
5. **Sulfate.** The Secondary MCL for sulfate is 250 mg/L as a recommended level, 500 mg/L as an upper level, and 600 mg/L as a short-term maximum.

(b) **RPA Results.**

- (1) **Chloride.** Chloride concentrations in the effluent ranged from 91 mg/L to 110 mg/L, with an average of 100 mg/L, for 4 samples collected by the Discharger during 2017. These levels do not exceed the Secondary MCL. Background receiving water chloride ranged from 5.9 mg/L to 12 mg/L, with an average of 7.8 mg/L, for 4 samples collected by the Discharger during 2017.
- (2) **Electrical Conductivity or Total Dissolved Solids.** A review of the Discharger's monitoring reports shows an average effluent EC of 930  $\mu\text{mhos/cm}$ , with a range from 639  $\mu\text{mhos/cm}$  to 1698  $\mu\text{mhos/cm}$ , for 1197 samples collected from August 2016 through September 2019. These levels do not exceed the recommended Secondary MCL. The background receiving water EC averaged 352  $\mu\text{mhos/cm}$ , with a range of from 229  $\mu\text{mhos/cm}$  to 542  $\mu\text{mhos/cm}$ , for 47 samples collected from August 2016 through September 2019. The average TDS effluent concentration was 575 mg/L with a range from 443 mg/L to 833 mg/L, for 42 samples collected from August 2016 through September 2019. These levels do not exceed the recommended Secondary MCL. The background receiving water TDS ranged from 208 mg/L to 274

mg/L, with an average of 230 mg/L, for 4 samples collected during 2017.

- (3) **Sulfate.** Sulfate concentrations in the effluent ranged from ND mg/L to 110 mg/L, with an average of 54 mg/L, for 4 samples collected by the Discharger during 2017. These levels do not exceed the Secondary MCL. Background receiving water sulfate ranged from 16 mg/L to 24 mg/L, with an average of 20 mg/L, for 4 samples collected by the Discharger during 2017.
- (c) **WQBELs.** As discussed above, the discharge does not have reasonable potential to cause or contribute to an instream excursion of water quality objectives for salinity. However, allowing the Discharger to increase its current salt loading may be contrary to the Region-wide effort to address salinity in the Central Valley. Therefore, this Order includes a performance-based effluent limitation of 1,300  $\mu\text{mhos/cm}$  for EC to be applied as an average annual effluent limitation (AAEL) to limit the discharge to current levels.

This performance-based AAEL represents the maximum annual average effluent EC concentration for a calendar year using data from August 2016 through September 2019, adjusted to account for possible drought, water conservation, and water recycling efforts. The maximum annual average of 1091  $\mu\text{mhos/cm}$  occurred during the year 2016.

In order to ensure that the Discharger will continue to control the discharge of salinity, this Order includes a requirement for the Discharger to continue to implement its Salinity Evaluation and Minimization Plan. Also, water supply monitoring is required to evaluate the relative contribution of salinity from the source water to the effluent.

On 17 January 2020, certain amendments to the Basin Plan incorporating a Program to Control and Permit Salt Discharges to Surface and Groundwater (Salt Control Program) became effective. Other amendments became effective on 2 November 2020 when approved by the U.S. EPA. The Salt Control Program is a three-phased program, with each phase lasting 10 to 15 years. The Basin Plan requires all salt dischargers to comply with the provisions of the program. Two compliance pathways are available for salt dischargers during Phase 1.

The Phase 1 Compliance pathways are: 1) Conservative Salinity Permitting Approach, which utilizes the existing regulatory structure and focuses on source control, conservative salinity

limits on the discharge, and limits the use of assimilative capacity and compliance time schedules; and, 2) Alternative Salinity Permitting Approach, which is an alternative approach to compliance through implementation of specific requirements such as participating in the Salinity Prioritization and Optimization Study (P&O) rather than the application of conservative discharge limits.

The performance-based AAEL for EC in this Order is consistent with the Alternative Salinity Permitting Approach and compliance with the effluent limit does not ensure the Facility can participate in the Conservative Salinity Permitting Approach. If the Discharger is authorized to participate in the Conservative Salinity Permitting Approach the conservative salinity limits required by the Salinity Control Program will be applied, which may result in more stringent effluent limits.

- (d) **Plant Performance and Attainability.** Analysis of the effluent data shows that the discharge has not exceeded the applicable performance-based effluent limitation. The Central Valley Water Board concludes, therefore, that immediate compliance with these effluent limitations is feasible.
- b. **Constituents with Reasonable Potential.** The Central Valley Water Board finds that the discharge has a reasonable potential to cause or contribute to an instream excursion above a water quality standard for ammonia, BOD<sub>5</sub>, electrical conductivity, mercury, nitrate plus nitrite, pH, total coliform organisms, and TSS. WQBELs for these constituents are included in this Order. A summary of the RPA is provided in Attachment G, and a detailed discussion of the RPA for each constituent is provided below.

- i. **Ammonia**

- (a) **WQO.** The 2013 U.S. EPA National Ambient Water Quality Criteria (NAWQC) for the protection of freshwater aquatic life for total ammonia (2013 Criteria), recommends acute (1-hour average; criteria maximum concentration or CMC) and chronic (30-day average; criteria continuous concentration or CCC) standards based on pH and temperature. U.S. EPA also recommends that no 4-day average concentration should exceed 2.5 times the 30-day CCC.

The 2013 Criteria reflects the latest scientific knowledge on the toxicity of ammonia to certain freshwater aquatic life, including toxicity data on sensitive freshwater unionid mussels, non-pulmonary snails, and other freshwater organisms. The inclusion of new toxicity data for unionid mussels resulted in substantially more stringent criteria. In many cases, current wastewater

treatment technologies are not capable of complying with effluent limitations based on the more stringent criteria.

The Central Valley Clean Water Association (CVCWA) organized a coordinated effort for POTWs within the Central Valley Region, the Freshwater Mussel Collaborative Study for Wastewater Treatment Plants, to determine how the latest scientific knowledge on the toxicity of ammonia reflected in the 2013 Criteria could be implemented in the Central Valley Region. Phase I, completed in June 2015, included a State of Knowledge Report developed by a consultant team consisting of Robertson-Bryan, Inc., Larry Walker Associates, and Pacific EcoRisk. The collaborative study involved policy and permitting discussions among representatives from the Central Valley Water Board, U.S. EPA, United States Fish and Wildlife Service (USFWS), California Department of Fish and Wildlife (CDFW), and regional mussel experts regarding the implementation of the 2013 Criteria in POTW NPDES permits. The discussions evaluated permitting approaches that provide reasonable protection of aquatic life beneficial uses, including protection of freshwater mussels.

The State of Knowledge Report explained that the species of freshwater mussels in waters within the Central Valley Region are different than what U.S. EPA used in the toxicity dataset for development of the 2013 Criteria. The State of Knowledge Report indicated that one resident freshwater mussel species was shown to not be as sensitive as the eastern mussel species used to derive the 2013 Criteria. However, the sensitivity of the other Central Valley Region mussel species was unknown.

Initial work under this project indicated the need to understand whether freshwater mussels are present or absent in POTW receiving waters in order to properly permit the discharge of ammonia in NPDES permits. Hence, a Phase II of the CVCWA study was conducted that developed and validated an effective environmental DNA (eDNA) method for determining the presence/absence of the three freshwater mussel genera in water bodies of the Central Valley. A Phase IIb of the study involved further study and application of the eDNA methodology.

CVCWA submitted the Phase IIc Freshwater Mussel Collaborative Study for Wastewater Treatment Plants: Ammonia Criteria Recalculation Final Report, dated January 2020 (Criteria Recalculation Report) developed by the same consultant team. The Criteria Recalculation Report provides toxicity studies demonstrating all freshwater mussel species present in Central Valley Region waters are less sensitive than the eastern species used to develop the 2013 Criteria.

U.S. EPA developed the Guidelines for Deriving Numerical Aquatic Site-Specific Water Quality Criteria by Modifying National Criteria (EPA-600/S3-84-099 December 1984) that provides a Recalculation Procedure. U.S. EPA also developed the Revised Deletion Process for the Site-Specific Recalculation Procedure for Aquatic Life Criteria (EPA-823-R-13-001, April 2013) to guide the development of a site-specific toxicity dataset that is appropriate for deriving a site-specific aquatic life criterion, by modifying the national toxicity dataset for the pollutant of concern through correcting, adding, and/or deleting test results.

The Criteria Recalculation Report implemented U.S. EPA's Recalculation Procedure utilizing toxicity bioassays conducted on resident mussel species to replace the toxicity data for the eastern mussel species in the national dataset to develop site-specific ammonia criteria for waters within the Central Valley Region, including all surface waters in the Sacramento River, San Joaquin River, and Tulare Lake Basin Plans.

A draft Criteria Recalculation Report was provided to the Central Valley Water Board, U.S. EPA Region 9, U.S. EPA Office of Science and Technology, USFWS, and the Nature Conservancy. Comments were provided by Central Valley Water Board staff and U.S. EPA Office of Science and Technology. U.S. EPA agreed with the recalculation procedure for developing site-specific acute criterion. However, U.S. EPA recommended a more conservative approach for utilizing the acute-to-chronic ratio procedure for developing the site-specific chronic criterion. The final Criteria Recalculation Report addressed the comments and provided revised equations for the chronic criterion in Appendix D.

The Basin Plans' Policy for Application of Water Quality Objectives requires the Central Valley Water Board to consider, "...on a case-by-case basis, direct evidence of beneficial use impacts, all material and relevant information submitted by the discharger and other interested parties, and relevant numerical criteria and guidelines developed and/or published by other agencies and organizations...In considering such criteria, the Board evaluates whether the specific numerical criteria which are available through these sources and through other information supplied to the Board, are relevant and appropriate to the situation at hand and, therefore, should be used in determining compliance with the narrative objective."

The Central Valley Water Board finds that the site-specific ammonia criteria provided in the January 2020 Criteria Recalculation Report implement the Basin Plan's narrative toxicity objective to protect aquatic life beneficial uses of the receiving water. This Order implements the site-specific acute and chronic

criteria for ammonia provided by the January 2020 Criteria Recalculation Report, with the adjustments to the chronic criteria recommended by U.S. EPA.

**Site-specific Criteria for South Fork of Putah Creek.** Similar to the U.S. EPA 2013 Criteria, the recalculated site-specific criteria developed in the Criteria Recalculation Report for the acute and chronic criteria are presented based on equations that vary according to pH and temperature. The pH and temperature speciation relationships developed by U.S. EPA were utilized without modification. Equations were developed for situations where freshwater mussels are present and where they are absent. In this case, for the South Fork of Putah Creek freshwater mussels have been assumed to be present. In addition, the recalculated criteria include equations that provide enhanced protection for important salmonid species in the genus *Oncorhynchus*, that can be implemented for receiving waters where salmonid species are present. Because the South Fork of Putah Creek has a potential beneficial use of cold freshwater habitat and the presence of salmonids in the South Fork of Putah Creek is well-documented, the criteria equations for waters where salmonids are present were used.

Order R5-2014-0152 established seasonal effluent limitations because the pH and temperature of the receiving water vary seasonally. Consistent with Order R5-2014-0152, seasonal water quality criteria were calculated for the winter season (i.e., November through April) and the summer season (i.e., May through October).

The acute (1-hour average) criterion or CMC was calculated using paired effluent pH and temperature data, collected during the period from August 2016 and September 2019. The most stringent CMCs for winter and summer of 7.28 mg/L and 5.62 mg/L (ammonia as N), respectively, calculated using the paired effluent pH and temperature data have been implemented in this Order.

The chronic (30-day average) criterion or CCC was calculated using paired downstream receiving water pH and temperature data, collected during the period from August 2016 and September 2019. The most stringent 30-day rolling average CCCs for winter and summer of 1.20 mg/L and 0.61 mg/L (ammonia as N), respectively, have been implemented in this Order.

The chronic (4-day average) concentration is derived in accordance with the U.S. EPA criterion as 2.5 times the 30-day CCC. Based on the 30-day CCCs for winter and summer of 1.20

mg/L and 0.61 mg/L (ammonia as N), respectively, the 4-day average concentrations that should not be exceeded for winter and summer are 2.99 mg/L and 1.51 mg/L (ammonia as N), respectively.

- (b) **RPA Results.** The Facility is a POTW that treats domestic wastewater. Untreated domestic wastewater contains ammonia in concentrations that is harmful to aquatic life and exceed the Basin Plan narrative toxicity objective. Federal regulations at 40 C.F.R. section 122.44(d)(1)(i) requires that, "Limitations must control all pollutants or pollutant parameters (either conventional, nonconventional, or toxic pollutants) which the Director determines are or may be discharged at a level which will cause, have the reasonable potential to cause, or contribute to an excursion above any State water quality standard, including State narrative criteria for water quality." For priority pollutants, the SIP dictates the procedures for conducting the RPA. Ammonia is not a priority pollutant. Therefore, the Central Valley Water Board is not restricted to one particular RPA method. Due to the site-specific conditions of the discharge, the Central Valley Water Board has used professional judgment in determining the appropriate method for conducting the RPA for this non-priority pollutant constituent.

U.S. EPA's September 2010 NPDES Permit Writer's Manual, page 6-30, states, "State implementation procedures might allow, or even require, a permit writer to determine reasonable potential through a qualitative assessment process without using available facility-specific effluent monitoring data or when such data are not available...A permitting authority might also determine that WQBELs are required for specific pollutants for all facilities that exhibit certain operational or discharge characteristics (e.g., WQBELs for pathogens in all permits for POTWs discharging to contact recreational waters)." U.S. EPA's TSD also recommends that factors other than effluent data should be considered in the RPA, "When determining whether or not a discharge causes, has the reasonable potential to cause, or contributes to an excursion of a numeric or narrative water quality criterion for individual toxicants or for toxicity, the regulatory authority can use a variety of factors and information where facility-specific effluent monitoring data are unavailable. These factors also should be considered with available effluent monitoring data." With regard to POTWs, U.S. EPA recommends that, "POTWs should also be characterized for the possibility of chlorine and ammonia problems." (TSD, p. 50)

Nitrification is a biological process that converts ammonia to nitrite

and nitrite to nitrate. Denitrification is a process that converts nitrate to nitrite or nitric oxide and then to nitrous oxide or nitrogen gas, which is then released to the atmosphere. The Discharger currently uses nitrification to remove ammonia from the waste stream. Inadequate or incomplete nitrification may result in the discharge of ammonia to the receiving stream. Ammonia is known to cause toxicity to aquatic organisms in surface waters. Discharges of ammonia in concentrations that produce detrimental physiological responses to human, plant, animal, or aquatic life would violate the Basin Plan's narrative toxicity objective. Although the Discharger nitrifies the discharge, inadequate or incomplete nitrification creates the potential for ammonia to be discharged and provides the basis for the discharge to have a reasonable potential to cause or contribute to an instream excursion above the site-specific acute and chronic criteria for ammonia provided by the January 2020 Criteria Recalculation Report. Therefore, the Central Valley Water Board finds the discharge has reasonable potential for ammonia and WQBELs are required.

- (c) **WQBELs.** The Central Valley Water Board calculates WQBELs in accordance with SIP procedures for non-CTR constituents, and ammonia is a non-CTR constituent. The SIP procedure assumes a 4-day averaging period for calculating the long-term average discharge condition (LTA). However, U.S. EPA recommends modifying the procedure for calculating permit limits for ammonia using a 30-day averaging period for the calculation of the LTA corresponding to the 30-day CCC. Therefore, while the LTAs corresponding to the acute and 4-day chronic criteria were calculated according to SIP procedures, the LTA corresponding to the 30-day CCC was calculated assuming a 30-day averaging period. The lowest LTA representing the acute, 4-day CCC, and 30-day CCC is then selected for deriving the average monthly effluent limitation (AMEL) and the average weekly effluent limitation (AWEL). The remainder of the WQBEL calculation for ammonia was performed according to the SIP procedures. This Order contains an AMEL and an AWEL for ammonia of 1.1 mg/L and 3.3 mg/L, respectively, for 1 November through 30 April, based on the NAWQC. This Order contains an AMEL and an AWEL for ammonia of 0.51 mg/L and 1.8 mg/L, respectively, for 1 May through 31 October, based on the NAWQC.
- (d) **Plant Performance and Attainability.** Analysis of 233 effluent samples during the winter season shows that the maximum average weekly concentration of 0.20 mg/L and the maximum average monthly concentration of 0.22 mg/L are less than the applicable AWEL and AMEL. Analysis of 265 effluent samples during the summer season shows that the maximum average



weekly concentration of 0.33 mg/L and the maximum average monthly concentration of 0.39 mg/L are less than the applicable AWEL and AMEL. The Central Valley Water Board concludes, therefore, that immediate compliance with these effluent limitations is feasible.

ii. **Nitrate and Nitrite**

- (a) **WQO.** The Division of Drinking Water (DDW) has adopted Primary MCLs for the protection of human health for nitrite and nitrate that are equal to 1 mg/L and 10 mg/L (measured as nitrogen), respectively. DDW has also adopted a Primary MCL of 10 mg/L for the sum of nitrate and nitrite, measured as nitrogen.

U.S. EPA has developed a primary MCL and an MCL goal of 1 mg/L for nitrite (as nitrogen). For nitrate, U.S. EPA has developed Drinking Water Standards (10 mg/L as Primary MCL) and NAWQC for protection of human health (10 mg/L for non-cancer health effects).

- (b) **RPA Results.** The Facility is a POTW that treats domestic wastewater. Untreated domestic wastewater contains ammonia in concentrations that is harmful to aquatic life and exceed the Basin Plan's narrative toxicity objective. This Order, therefore, requires removal of ammonia (i.e., nitrification). Nitrification is a biological process that converts ammonia to nitrate and nitrite, and will result in effluent nitrate concentrations above the Primary MCL for nitrate plus nitrite. Nitrate concentrations in a drinking water supply above the Primary MCL threatens the health of human fetuses and newborn babies by reducing the oxygen-carrying capacity of the blood (methemoglobinemia).

Federal regulations at 40 C.F.R. section 122.44(d)(1)(i) requires that, "Limitations must control all pollutants or pollutant parameters (either conventional, nonconventional, or toxic pollutants) which the Director determines are or may be discharged at a level which will cause, have the reasonable potential to cause, or contribute to an excursion above any State water quality standard, including State narrative criteria for water quality." For priority pollutants, the SIP dictates the procedures for conducting the RPA. Nitrate and nitrite are not priority pollutants. Therefore, the Central Valley Water Board is not restricted to one particular RPA method. Due to the site-specific conditions of the discharge, the Central Valley Water Board has used professional judgment in determining the appropriate method for conducting the RPA for this non-priority pollutant constituent.

U.S. EPA's September 2010 NPDES Permit Writer's Manual, page 6-30, states, "State implementation procedures might allow,

or even require, a permit writer to determine reasonable potential through a qualitative assessment process without using available facility-specific effluent monitoring data or when such data are not available...A permitting authority might also determine that WQBEL's are required for specific pollutants for all facilities that exhibit certain operational or discharge characteristics (e.g., WQBEL's for pathogens in all permits for POTW's discharging to contact recreational waters)." U.S. EPA's TSD also recommends that factors other than effluent data should be considered in the RPA, "When determining whether or not a discharge causes, has the reasonable potential to cause, or contributes to an excursion of a numeric or narrative water quality criterion for individual toxicants or for toxicity, the regulatory authority can use a variety of factors and information where facility-specific effluent monitoring data are unavailable. These factors also should be considered with available effluent monitoring data." With regard to POTW'S, U.S. EPA recommends that, "POTW's should also be characterized for the possibility of chlorine and ammonia problems." (TSD, p. 50)

The concentration of nitrogen in raw domestic wastewater is sufficiently high that the resultant treated wastewater has a reasonable potential to exceed or threat to exceed the Primary MCL for nitrate plus nitrite unless the wastewater is treated for nitrogen removal, and therefore an effluent limit for nitrate plus nitrite is required. Denitrification is a process that converts nitrate to nitrite or nitric oxide and then to nitrous oxide or nitrogen gas, which is then released to the atmosphere. The Discharger currently uses nitrification/denitrification to remove ammonia, nitrite, and nitrate from the waste stream. Inadequate or incomplete denitrification may result in the discharge of nitrate and/or nitrite to the receiving stream. Discharges of nitrate plus nitrite in concentrations that exceed the Primary MCL would violate the Basin Plan's narrative chemical constituents' objective. Although the Discharger denitrifies the discharge, inadequate or incomplete denitrification creates the potential for nitrate and nitrite to be discharged and provides the basis for the discharge to have a reasonable potential to cause or contribute to an in-stream excursion above the Primary MCL. Therefore, the Central Valley Water Board finds the discharge has reasonable potential for nitrate plus nitrite and WQBEL's are required.

- (c) **WQBELs.** This Order contains an AMEL and an AWEL for nitrate plus nitrite of 10 mg/L and 15 mg/L, respectively, based on the Basin Plan's narrative chemical constituent objectives for protection of the MUN beneficial use. These effluent limitations are included in this Order to assure the treatment process

adequately nitrifies and denitrifies the waste stream to protect the beneficial use of municipal and domestic supply.

- (d) **Plant Performance and Attainability.** Analysis of the effluent data shows that the MEC for nitrate plus nitrite of 18.72 mg/L was the only sample that exceeded the Primary MCL. The discharge did not exceed the applicable AMEL contained in the existing permit. Therefore, the Central Valley Water Board concludes that immediate compliance with these effluent limitations is feasible.

### iii. Pathogens

- (a) **WQO.** DDW has developed reclamation criteria, CCR, Division 4, Chapter 3 (Title 22), for the reuse of wastewater. Title 22 requires that for spray irrigation of food crops, parks, playgrounds, schoolyards, and other areas of similar public access, wastewater be adequately disinfected, oxidized, coagulated, clarified, and filtered, and that the effluent total coliform levels not exceed 2.2 MPN/100 mL as a 7-day median; 23 MPN/100 mL, not to be exceeded more than once in a 30-day period; and 240 MPN/100 mL, at any time.

Title 22 also requires that recycled water used as a source of water supply for non-restricted recreational impoundments be disinfected tertiary recycled water that has been subjected to conventional treatment. A non-restricted recreational impoundment is defined as "...an impoundment of recycled water, in which no limitations are imposed on body-contact water recreational activities." Title 22 is not directly applicable to surface waters; however, the Central Valley Water Board finds that it is appropriate to apply an equivalent level of treatment to that required by the DDW's reclamation criteria because the receiving water is used for irrigation of agricultural land and for contact recreation purposes. The stringent disinfection criteria of Title 22 are appropriate since the undiluted effluent may be used for the irrigation of food crops and/or for body-contact water recreation. Coliform organisms are intended as an indicator of the effectiveness of the entire treatment train and the effectiveness of removing other pathogens.

- (b) **RPA Results.** Raw domestic wastewater inherently contains human pathogens that threaten human health and life, and constitute a threatened pollution and nuisance under CWC section 13050 if discharged untreated to the receiving water. Reasonable potential for pathogens therefore exists and WQBELs are required.

Federal regulations at 40 C.F.R. section 122.44(d)(1)(i) requires that, "Limitations must control all pollutants or pollutant

parameters (either conventional, nonconventional, or toxic pollutants) which the Director determines are or may be discharged at a level which will cause, have the reasonable potential to cause, or contribute to an excursion above any State water quality standard, including State narrative criteria for water quality." For priority pollutants, the SIP dictates the procedures for conducting the RPA. Pathogens are not priority pollutants. Therefore, the Central Valley Water Board is not restricted to one particular RPA method. Due to the site-specific conditions of the discharge, the Central Valley Water Board has used professional judgment in determining the appropriate method for conducting the RPA for this non-priority pollutant constituent.

U.S. EPA's September 2010 NPDES Permit Writer's Manual, page 6-30, states, "State implementation procedures might allow, or even require, a permit writer to determine reasonable potential through a qualitative assessment process without using available facility-specific effluent monitoring data or when such data are not available...A permitting authority might also determine that WQBELs are required for specific pollutants for all facilities that exhibit certain operational or discharge characteristics (e.g., WQBELs for pathogens in all permits for POTWs discharging to contact recreational waters)." U.S. EPA's TSD also recommends that factors other than effluent data should be considered in the RPA, "When determining whether or not a discharge causes, has the reasonable potential to cause, or contributes to an excursion of a numeric or narrative water quality criterion for individual toxicants or for toxicity, the regulatory authority can use a variety of factors and information where facility-specific effluent monitoring data are unavailable. These factors also should be considered with available effluent monitoring data." (TSD, p. 50)

The beneficial uses of the South Fork of Putah Creek include municipal and domestic supply, water contact recreation, and agricultural irrigation supply, and there is, at times, less than 20:1 dilution. To protect these beneficial uses, the Central Valley Water Board finds that the wastewater must be disinfected and adequately treated to prevent disease. Although the Discharger provides disinfection, inadequate or incomplete disinfection creates the potential for pathogens to be discharged. Therefore, the Central Valley Water Board finds the discharge has reasonable potential for pathogens and WQBELs are required.

- (c) **WQBELs.** In accordance with the requirements of Title 22, this Order includes effluent limitations for total coliform organisms of 2.2 MPN/100 mL as a 7-day median; 23 MPN/100 mL, not to be

exceeded more than once in a 30-day period; and 240 MPN/100 mL as an instantaneous maximum.

The tertiary treatment process, or equivalent, is capable of reliably treating wastewater to a turbidity level of 2 nephelometric turbidity units (NTU) as a daily average. Failure of the filtration system such that virus removal is impaired would normally result in increased particles in the effluent, which result in higher effluent turbidity. Turbidity has a major advantage for monitoring filter performance. Coliform testing, by comparison, is not conducted continuously and requires several hours, to days, to identify high coliform concentrations. Therefore, to ensure compliance with the DDW recommended Title 22 disinfection criteria, weekly average specifications are impracticable for turbidity. This Order includes operational specifications for turbidity of 2 NTU as a daily average; 5 NTU, not to be exceeded more than 5 percent of the time within a 24-hour period; and 10NTU as an instantaneous maximum.

This Order contains effluent limitations for BOD<sub>5</sub>, total coliform organisms, and TSS and requires a tertiary level of treatment, or equivalent, necessary to protect the beneficial uses of the receiving water. The Central Valley Water Board has previously considered the factors in Water Code section 13241 in establishing these requirements.

Final WQBELs for BOD<sub>5</sub> and TSS are based on the technical capability of the tertiary process, which is necessary to protect the beneficial uses of the receiving water. BOD<sub>5</sub> is a measure of the amount of oxygen used in the biochemical oxidation of organic matter. The tertiary treatment standards for BOD<sub>5</sub> and TSS are indicators of the effectiveness of the tertiary treatment process. The principal design parameter for wastewater treatment plants is the daily BOD<sub>5</sub> and TSS loading rates and the corresponding removal rate of the system. The application of tertiary treatment processes results in the ability to achieve lower levels for BOD<sub>5</sub> and TSS than the secondary standards currently prescribed. Therefore, this Order requires AMELs for BOD<sub>5</sub> and TSS of 10 mg/L, which is technically based on the capability of a tertiary system. In addition to the AMELs and AWELs, a maximum daily effluent limitation (MDEL) for BOD<sub>5</sub> and TSS is included in the Order to ensure that the treatment works are not organically overloaded and operate in accordance with design capabilities.

- (d) **Plant Performance and Attainability.** The Facility is designed to achieve Title 22 criteria. The Central Valley Water Board concludes, therefore, that immediate compliance with these effluent limitations is feasible.

iv. **pH**

- (a) **WQO.** The Basin Plan includes a water quality objective for surface waters (except for Goose Lake) that the “pH shall not be depressed below 6.5 nor raised above 8.5.”
- (b) **RPA Results.** Raw domestic wastewater inherently has variable pH. Additionally, some wastewater treatment processes can increase or decrease wastewater pH which if not properly controlled, would violate the Basin Plan’s numeric objective for pH in the receiving water. Therefore, reasonable potential exists for pH and WQBELs are required.

Federal regulations at 40 C.F.R. section 122.44(d)(1)(i) requires that, “Limitations must control all pollutants or pollutant parameters (either conventional, nonconventional, or toxic pollutants) which the Director determines are or may be discharged at a level which will cause, have the reasonable potential to cause, or contribute to an excursion above any State water quality standard, including State narrative criteria for water quality.” For priority pollutants, the SIP dictates the procedures for conducting the RPA. pH is not a priority pollutant. Therefore, the Central Valley Water Board is not restricted to one particular RPA method. Due to the site-specific conditions of the discharge, the Central Valley Water Board has used professional judgment in determining the appropriate method for conducting the RPA for this non-priority pollutant constituent.

U.S. EPA’s September 2010 NPDES Permit Writer’s Manual, page 6-30, states, “State implementation procedures might allow, or even require, a permit writer to determine reasonable potential through a qualitative assessment process without using available facility-specific effluent monitoring data or when such data are not available...A permitting authority might also determine that WQBELs are required for specific pollutants for all facilities that exhibit certain operational or discharge characteristics (e.g., WQBELs for pathogens in all permits for POTWs discharging to contact recreational waters).” U.S. EPA’s TSD also recommends that factors other than effluent data should be considered in the RPA, “When determining whether or not a discharge causes, has the reasonable potential to cause, or contributes to an excursion of a numeric or narrative water quality criterion for individual toxicants or for toxicity, the regulatory authority can use a variety of factors and information where facility-specific effluent monitoring data are unavailable. These factors also should be considered with available effluent monitoring data.” (TSD, p. 50)

The Facility is a POTW that treats domestic wastewater. Based on 1159 samples taken from August 2016 through September

2019, the maximum pH reported was 8.0 and the minimum was 6.5. The Facility did not exceed the instantaneous maximum or minimum effluent limitations. Although the Discharger has proper pH controls in place, the pH for the Facility's influent varies due to the nature of municipal sewage, which provides the basis for the discharge to have a reasonable potential to cause or contribute to an instream excursion above the Basin Plan's numeric objective for pH in the receiving water. Therefore, WQBELs for pH are required in this Order.

- (c) **WQBELs.** Effluent limitations for pH of 6.5 as an instantaneous minimum and 8.5 as an instantaneous maximum are included in this Order based on protection of the Basin Plan objectives for pH.
- (d) **Plant Performance and Attainability.** Analysis of the effluent data shows that the discharge has not exceeded the applicable WQBELs. The Central Valley Water Board concludes, therefore, that immediate compliance with these effluent limitations is feasible.

#### 4. WQBEL Calculations

- a. This Order includes WQBELs for ammonia, BOD<sub>5</sub>, nitrate plus nitrite, pH, total coliform organisms, and TSS. The general methodology for calculating WQBELs based on the different criteria/objectives is described in subsections IV.C.4.b through e, below. See Attachment H for the WQBEL calculations.
- b. **Effluent Concentration Allowance.** For each water quality criterion/objective, the ECA is calculated using the following steady-state mass balance equation from section 1.4 of the SIP:

$$\text{ECA} = C + D(C - B) \text{ where } C \text{ greater than } B, \text{ and}$$
$$\text{ECA} = C \text{ where } C \text{ less than or equal to } B$$

where:

ECA = effluent concentration allowance  
D = dilution credit  
C = the priority pollutant criterion/objective  
B = the ambient background concentration.

According to the SIP, the ambient background concentration (B) in the equation above shall be the observed maximum with the exception that an ECA calculated from a priority pollutant criterion/objective that is intended to protect human health from carcinogenic effects shall use the arithmetic mean concentration of the ambient background samples.

- c. **Primary and Secondary MCLs.** For non-priority pollutants with primary MCL's to protect human health (e.g., nitrate plus nitrite), the AMEL is set equal to the primary MCL and the AWEL is calculated using the AWEL/AMEL multiplier, where the AWEL multiplier is based on a 98<sup>th</sup> percentile occurrence probability and the AMEL multiplier is from Table 2 of the SIP.

For non-priority pollutants with secondary MCL's that protect public welfare (e.g., taste, odor, and staining), WQBELs were calculated by setting the LTA equal to the secondary MCL and using the AMEL multiplier to set the AMEL. The AWEL was calculated using the MDEL/AMEL multiplier from Table 2 of the SIP.

- d. **Aquatic Toxicity Criteria.** For priority pollutants with acute and chronic aquatic toxicity criteria, the WQBELs are calculated in accordance with section 1.4 of the SIP. The ECAs are converted to equivalent long-term averages (i.e. LTA<sub>acute</sub> and LTA<sub>chronic</sub>) using statistical multipliers and the lowest LTA is used to calculate the AMEL and MDEL using additional statistical multipliers. For non-priority pollutants, WQBELs are calculated using similar procedures, except that an AWEL is determined utilizing multipliers based on a 98<sup>th</sup> percentile occurrence probability.
- e. **Human Health Criteria.** For priority pollutants with human health criteria, the WQBELs are calculated in accordance with section 1.4 of the SIP. The AMEL is set equal to the ECA and the MDEL is calculated using the MDEL/AMEL multiplier from Table 2 of the SIP. For non-priority pollutants with human health criteria, WQBELs are calculated using similar procedures, except that an AWEL is established using the MDEL/AMEL multiplier from Table 2 of the SIP.

$$AMEL = mult_{AMEL} \left[ \min \left( \overbrace{M_A ECA_{acute}}^{LTA_{acute}}, M_C ECA_{chronic} \right) \right]$$

$$MDEL = mult_{MDEL} \left[ \min \left( M_A ECA_{acute}, \underbrace{M_C ECA_{chronic}}_{LTA_{chronic}} \right) \right]$$

$$MDEL_{HH} = \left( \frac{mult_{MDEL}}{mult_{AMEL}} \right) AMEL_{HH}$$

where:

- mult<sub>AMEL</sub> = statistical multiplier converting minimum LTA to AMEL
- mult<sub>MDEL</sub> = statistical multiplier converting minimum LTA to MDEL
- M<sub>A</sub> = statistical multiplier converting acute ECA to LTA<sub>acute</sub>
- M<sub>C</sub> = statistical multiplier converting chronic ECA to LTA<sub>chronic</sub>



**Summary of Water Quality-Based Effluent Limitations  
Discharge Points 001 and 002**

**Table F-10. Summary of Water Quality-Based Effluent Limitations**

<b>Parameter</b>	<b>Units</b>	<b>Average Monthly Effluent Limitations</b>	<b>Average Weekly Effluent Limitations</b>	<b>Maximum Daily Effluent Limitations</b>
BOD <sub>5</sub>	mg/L	10	15	--
TSS	mg/L	10	15	--
Ammonia Nitrogen, Total (as N) (1 May – 31 October)	mg/L	0.51	1.8	--
Ammonia Nitrogen, Total (as N) (1 May – 31 October)	lbs/day	16	55	--
Ammonia Nitrogen, Total (as N) (1 November – 30 April)	mg/L	1.1	3.3	--
Ammonia Nitrogen, Total (as N) (1 November – 30 April)	lbs/day	34	100	--
Nitrate plus Nitrite (as N)	mg/L	10	15	--
pH	standard units	--	--	8.5; 6.5
Total Coliform Organisms	MPN/100mL	2.2 as 7-day median; 23 more than once/30-day period; 240 at any time	--	--

**Table F-10 Notes:**

1. **Mass limits** are based on an average dry weather flow of 3.6 MGD.
2. **The pH effluent limits** are an instantaneous maximum and an instantaneous minimum.

**5. Whole Effluent Toxicity (WET)**

For compliance with the Basin Plan’s narrative toxicity objective, this Order requires the Discharger to conduct whole effluent toxicity testing for acute and chronic toxicity, as specified in the MRP (Attachment E section V.). This Order also contains effluent limitations for acute and chronic toxicity and requires the Discharger to implement best management practices to investigate the causes of and identify corrective actions to reduce or eliminate effluent toxicity.

- a. **Acute Aquatic Toxicity.** The Basin Plan contains a narrative toxicity objective that states, “All waters shall be maintained free of toxic

substances in concentrations that produce detrimental physiological responses in human, plant, animal, or aquatic life.” (Basin Plan at section 3.1.20) The Basin Plan also states that, “...effluent limits based upon acute biotoxicity tests of effluents will be prescribed where appropriate...”.

For priority pollutants, the SIP dictates the procedures for conducting the RPA. Acute toxicity is not a priority pollutant. Therefore, the Central Valley Water Board is not restricted to one particular RPA method. Acute whole effluent toxicity is not a priority pollutant. Therefore, due to the site-specific conditions of the discharge, the Central Valley Water Board has used professional judgment in determining the appropriate method for conducting the RPA. U.S. EPA’s September 2010 NPDES Permit Writer’s Manual, page 6-30, states, “State implementation procedures might allow, or even require, a permit writer to determine reasonable potential through a qualitative assessment process without using available facility-specific effluent monitoring data or when such data are not available...A permitting authority might also determine that WQBELs are required for specific pollutants for all facilities that exhibit certain operational or discharge characteristics (e.g., WQBELs for pathogens in all permits for POTWs discharging to contact recreational waters).” Although the discharge has been consistently in compliance with the acute effluent limitations, the Facility is a POTW that treats domestic wastewater containing ammonia and other acutely toxic pollutants. Acute toxicity effluent limits are required to ensure compliance with the Basin Plan’s narrative toxicity objective.

U.S. EPA Region 9 provided guidance for the development of acute toxicity effluent limitations in the absence of numeric water quality objectives for toxicity in its document titled "Guidance for NPDES Permit Issuance", dated February 1994. In section B.2. "Toxicity Requirements" (pgs. 14-15) it states that, "In the absence of specific numeric water quality objectives for acute and chronic toxicity, the narrative criterion 'no toxics in toxic amounts' applies. Achievement of the narrative criterion, as applied herein, means that ambient waters shall not demonstrate for acute toxicity: 1) less than 90% survival, 50% of the time, based on the monthly median, or 2) less than 70% survival, 10% of the time, based on any monthly median. For chronic toxicity, ambient waters shall not demonstrate a test result of greater than 1 TUc." Accordingly, effluent limitations for acute toxicity have been included in this Order as follows:

**Acute Toxicity.** Survival of aquatic organisms in 96-hour bioassays of undiluted waste shall be no less than:

70%, minimum for any one bioassay; and

90%, median for any three consecutive bioassays.

- b. **Chronic Aquatic Toxicity.** The Basin Plan contains a narrative toxicity objective that states, “All waters shall be maintained free of toxic

substances in concentrations that produce detrimental physiological responses in human, plant, animal, or aquatic life.” (Basin Plan at page section 3.1.20) The table below is chronic WET testing performed by the Discharger from August 2016 through September 2019. This data was used to determine if the discharge has reasonable potential to cause or contribute to an instream excursion above the Basin Plan’s narrative toxicity objective.

**Table F-11. Whole Effluent Chronic Toxicity Testing Results**

Date	Fathead Minnow Pimephales promelas Survival (TUc)	Fathead Minnow Pimephales Growth (TUc)	Water Flea Ceriodaphnia dubia Survival (TUc)	Water Flea Ceriodaphnia dubia Reproduction (TUc)	Green Algae Selenastrum capricornutum Growth (TUc)
3 <sup>rd</sup> Quarter 2016	1	1	1	1	greater than 1
Retest 3 <sup>rd</sup> Quarter 2016	--	--	--	--	1
4 <sup>th</sup> Quarter 2016	1	1	1	1	1
1 <sup>st</sup> Quarter 2017	1	1	1	1	1
2 <sup>nd</sup> Quarter 2017	1	1	1	1	greater than 1
3 <sup>rd</sup> Quarter 2017	less than 100%	greater than 1	1	greater than 1	1
Accelerated Monitoring	--	--	1	greater than 1	--
4 <sup>th</sup> Quarter 2017	1	1	1	1	1
1 <sup>st</sup> Quarter 2018	1	greater than 1	1	1	1
2 <sup>nd</sup> Quarter 2018	1	1	1	1	1
3 <sup>rd</sup> Quarter 2018	1	1	1	1	greater than 1
4 <sup>th</sup> Quarter 2018	1	1	1	greater than 1	1
4 <sup>th</sup> Quarter 2018 TRE	--	--	1	greater than 8	--
1 <sup>st</sup> Quarter 2019 TRE	--	--	1	1	--
1 <sup>st</sup> Quarter 2019	1	1	1	1	1

Date	Fathead Minnow Pimephales promelas Survival (TUc)	Fathead Minnow Pimephales promelas Growth (TUc)	Water Flea Ceriodaphnia dubia Survival (TUc)	Water Flea Ceriodaphnia dubia Reproduction (TUc)	Green Algae Selenastrum capricornutum Growth (TUc)
2 <sup>nd</sup> Quarter 2019	1	1	1	greater than 1	1
3 <sup>rd</sup> Quarter 2019	1	1	1	1	1

- i. **RPA.** No dilution has been granted for chronic whole effluent toxicity. Chronic toxicity testing results exceeding 1.3 chronic toxicity units (TUc) (as 100/NOEC) and a percent effect at 100 percent effluent exceeding 25 percent demonstrates the discharge has a reasonable potential to cause or contribute to an exceedance of the Basin Plan’s narrative toxicity objective. Based on chronic toxicity testing conducted between August 2016 and September 2019, the maximum chronic toxicity result was greater than 8 TUc for Ceriodaphnia dubia reproduction during a TRE on 4 December 2018 with a percent effect at 100 percent effluent of 21.65 percent.

The discharger experiences intermittent low-level toxicity and the Discharger initiated a TRE following the WET test in the third quarter of 2018 when the chronic toxicity result for Ceriodaphnia dubia reproduction was greater than 1 TUc with a percent effect of 57.75 percent. The TRE has been inconclusive and is ongoing. Therefore, the discharge does have reasonable potential to cause or contribute to an instream exceedance of the Basin Plan’s narrative toxicity objective.

- ii. **WQBELs.** The effluent chronic toxicity shall not exceed 1.3 chronic toxicity units (as 100/NOEC) AND a percent effect of 25 percent at 100 percent effluent, for any endpoint as the median of up to three consecutive chronic toxicity tests within a 6-week period. Per the compliance schedule described in section VI.C.7.a of the Order, these final effluent limits are effective 1 April 2028. The State Water Board is developing new statewide toxicity provisions through the Water Quality Control Plan for Inland Surface Waters, Enclosed Bays, and Estuaries of California that will be applicable to the Discharger. Upon the effective date of the Water Quality Control Plan, the Central Valley Water Board intends to incorporate the new toxicity provisions at the next 5-year permit renewal. It is expected the new Statewide toxicity provisions will be effective prior to implementation of the final WQBELs for chronic WET in this Order.

## D. Final Effluent Limitation Considerations

### 1. Mass-based Effluent Limitations

40 C.F.R section 122.45(f)(1) requires effluent limitations be expressed in terms of mass, with some exceptions, and 40 C.F.R. section 122.45(f)(2) allows pollutants that are limited in terms of mass to additionally be limited in terms of other units of measurement. This Order includes effluent limitations expressed in terms of mass and concentration. In addition, pursuant to the exceptions to mass limitations provided in 40 C.F.R. section 122.45(f)(1), some effluent limitations are not expressed in terms of mass, such as pH and temperature, and when the applicable standards are expressed in terms of concentration (e.g., CTR criteria and MCL's) and mass limitations are not necessary to protect the beneficial uses of the receiving water.

Mass-based effluent limitations were calculated based upon the design flow (Average Dry Weather Flow) permitted in Prohibition III.E of this Order.

### 2. Averaging Periods for Effluent Limitations

40 C.F.R. section 122.45 (d) requires average weekly and average monthly discharge limitations for POTWs unless impracticable. For pH, weekly average effluent limitations have been replaced with instantaneous maximum and instantaneous minimum effluent limitations. The rationale for using shorter averaging periods for these constituents is discussed in section IV.C.3 of this Fact Sheet.

### 3. Satisfaction of Anti-Backsliding Requirements

The CWA specifies that a revised permit may not include effluent limitations that are less stringent than the previous permit unless a less stringent limitation is justified based on exceptions to the anti-backsliding provisions contained in CWA sections 402(o) or 303(d)(4), or, where applicable, 40 C.F.R. section 122.44(l).

The effluent limitations in this Order are at least as stringent as the effluent limitations in the previous Order, with the exception of effluent limitations for ammonia (the seasonal AMEL from 1 November to 30 April), electrical conductivity, total residual chlorine, and the MDELs and mass limits for BOD<sub>5</sub> and TSS. The effluent limitations for these pollutants are less stringent than those in Order R5-2014-0152. This relaxation of effluent limitations is consistent with the anti-backsliding requirements of the CWA and federal regulations.

- a. **CWA section 402(o)(1) and 303(d)(4).** CWA section 402(o)(1) prohibits the establishment of less stringent water quality-based effluent limits "except in compliance with Section 303(d)(4)." CWA section 303(d)(4) has two parts: paragraph (A) which applies to nonattainment waters and paragraph (B) which applies to attainment waters.

- i. For waters where standards are not attained, CWA section 303(d)(4)(A) specifies that any effluent limit based on a TMDL or other WLA may be revised only if the cumulative effect of all such revised effluent limits based on such TMDLs or WLAs will assure the attainment of such water quality standards.
- ii. For attainment waters, CWA section 303(d)(4)(B) specifies that a limitation based on a water quality standard may be relaxed where the action is consistent with the antidegradation policy.

The South Fork of Putah Creek is considered an attainment water for ammonia, electrical conductivity, total residual chlorine, BOD<sub>5</sub>, and TSS because the receiving water is not listed as impaired on the 303(d) list for these parameters.<sup>10</sup> As discussed in section IV.D.4, below, removal or relaxation of the effluent limits complies with federal and state antidegradation requirements. Thus, removal or relaxation of the effluent limitations for ammonia, electrical conductivity, total residual chlorine, BOD<sub>5</sub>, and TSS from Order R5-2014-0152 meets the exception in CWA section 303(d)(4)(B).

- b. **CWA section 402(o)(2).** CWA section 402(o)(2) provides several exceptions to the anti-backsliding regulations. CWA 402(o)(2)(B)(i) allows a renewed, reissued, or modified permit to contain a less stringent effluent limitation for a pollutant if information is available which was not available at the time of permit issuance (other than revised regulations, guidance, or test methods) and which would have justified the application of a less stringent effluent limitation at the time of permit issuance.

As described further in section IV.C.3 of this Fact Sheet, updated information that was not available at the time Order R5-2014-0152 was issued indicates that total residual chlorine does not exhibit reasonable potential to cause or contribute to an exceedance of water quality objectives in the receiving water. Additionally, based on updated information that was not available at the time Order R5-2014-0152 was issued indicates that less stringent effluent limitations for ammonia, BOD<sub>5</sub>, and TSS satisfy requirements in CWA section 402(o)(2). The updated information that supports the relaxation of effluent limitations for these constituents includes the following:

- i. **Ammonia.** Effluent and receiving water monitoring data collected between August 2016 and September 2019 resulted in an AMEL for the winter season that is less stringent than the AMEL for the winter season in Order R5-2014-0152. The ammonia effluent limits are based on the current dataset for ammonia, pH, and temperature, and updated

---

<sup>10</sup> “The exceptions in section 303(d)(4) address both waters in attainment with water quality standards and those not in attainment, i.e. waters on the section 303(d) impaired waters list.” State Water Board Order WQ 2008-0006, Berry Petroleum Company, Poso Creek/McVan Facility.

ammonia criteria. Calculation of the ammonia limits are detailed in section IV.C.3.b.i.

- ii. **Total Residual Chlorine.** The Facility uses UV disinfection to treat the effluent discharge. Order R5-2014-0152 included effluent limits for total residual chlorine because chlorine was previously used at the Facility for cleaning and maintenance of the cloth disc filter. The Discharger no longer uses chlorine at the Facility. Therefore, there is no reasonable potential to cause or contribute to an exceedance of the NAWQC criterion for chlorine.

Thus, removal or relaxation of the effluent limitations for ammonia and total residual chlorine from Order R5-2014-0152 is in accordance with CWA section 402(o)(2)(B)(i), which allows for the removal or relaxation of effluent limitations based on information that was not available at the time of permit issuance.

- c. **Flow.** Order R5-2014-0152 included flow as an effluent limit based on the Facility design flow. Compliance with the effluent limit for flow in Order R5-2014-0152 was calculated annually based on the average daily flow collected over three consecutive dry weather months. Flow is not a pollutant and therefore has been changed from an effluent limit to a discharge prohibition in this Order, which is an equivalent level of regulation. This Order is not less stringent because compliance with flow as a discharge prohibition will be calculated the same way as the previous Order. Flow as a discharge prohibition adequately regulates the Facility, does not allow for an increase in the discharge of pollutants, and does not constitute backsliding.

#### 4. Antidegradation Policies

This Order does not allow for an increase in flow or mass of pollutants to the receiving water. Therefore, a complete antidegradation analysis is not necessary. The Order requires compliance with applicable federal technology-based standards and with WQBELs where the discharge could have the reasonable potential to cause or contribute to an exceedance of water quality standards. The permitted discharge is consistent with the antidegradation provisions of 40 C.F.R. section 131.12 and the State Anti-Degradation Policy. Compliance with these requirements will result in the use of best practicable treatment or control of the discharge. The impact on existing water quality will be insignificant.

- a. **Surface Water.** This Order removes effluent limitations for total residual chlorine because chlorine is not used at the Facility and therefore will not cause or contribute to an exceedance of the applicable water quality criteria or objectives in the receiving water. This Order relaxes effluent limitations for ammonia and electrical conductivity based on updated monitoring data. The removal and relaxation of effluent limits for these parameters will maintain the best practicable treatment or control of the

discharge necessary to assure that a pollution or nuisance will not occur and the highest water quality consistent with maximum benefit to the people of the State will be maintained. Thus, the removal and relaxation of effluent limitations is consistent with the antidegradation provisions of 40 C.F.R. section 131.12 and State Water Board Resolution No. 68-16.

This Order also removes the MDELs and mass-based effluent limitations for BOD<sub>5</sub> and TSS based on 40 CFR parts 122.45 (d) and (f). The removal of MDELs and mass-based effluent limits for BOD<sub>5</sub> and TSS will not result in a decrease in the level of treatment or control or a reduction in water quality.

Furthermore, both concentration-based AMELs and AWELs remain for BOD<sub>5</sub> and TSS, as well as an average dry weather flow prohibition that limits the amount of flow that can be discharged to the receiving water during dry weather months. The combination of concentration-based effluent limits and a flow prohibition in this Order are equivalent to mass-based effluent limitations, which were redundant limits contained in previous Orders by multiplying the concentration-based effluent limits and permitted average dry weather flow by a conversion factor to determine the mass-based effluent limitations. The Central Valley Water Board finds that the removal of MDELs and mass-based effluent limits for BOD<sub>5</sub> and TSS does not result in an allowed increase in pollutants or any additional degradation of the receiving water. Thus, the removal of MDELs and mass-based effluent limits for BOD<sub>5</sub> and TSS is consistent with the antidegradation provisions of 40 C.F.R. section 131.12 and the State Antidegradation Policy.

- b. **Groundwater.** The Discharger utilizes sludge stabilization ponds and sludge drying beds to process sludge solids removed from the waste stream. The stabilization ponds are clay-lined and the drying beds are lined with asphalt. Groundwater monitoring data gathered from April 2015 through August 2019 for electrical conductivity and nitrate show that the stabilization ponds and drying beds are not contributing to degradation of the groundwater.

## 5. Stringency of Requirements for Individual Pollutants

This Order contains both technology-based effluent limitations and WQBELs for individual pollutants. The technology-based effluent limitations consist of restrictions on BOD<sub>5</sub>, pH, and TSS. Restrictions on BOD<sub>5</sub>, pH, and TSS are discussed in IV.B.2 in this Fact Sheet. This Order's technology-based pollutant restrictions implement the minimum, applicable federal technology-based requirements. In addition, this Order contains effluent limitations more stringent than the minimum, federal technology-based requirements that are necessary to meet water quality standards. For pH, both technology-based effluent limitations and water quality-based effluent limitations are applicable. The more stringent of these effluent limitations are implemented by this Order. These



requirements include some limitations that are more stringent than required by the CWA.

WQBELs have been derived to implement water quality objectives that protect beneficial uses. Both the beneficial uses and the water quality objectives have been approved pursuant to federal law and are the applicable federal water quality standards. To the extent that toxic pollutant WQBELs were derived from the CTR, the CTR is the applicable standard pursuant to 40 C.F.R. section 131.38. The procedures for calculating the individual water quality-based effluent limitations for priority pollutants are based on the CTR implemented by the SIP, which was approved by U.S. EPA on 18 May 2000. Collectively, this Order's restrictions on individual pollutants are no more stringent than required to implement the requirements of the CWA.

**Summary of Final Effluent Limitations  
Discharge Points 001 and 002**

**Table F-12. Summary of Final Effluent Limitations**

<b>Parameter</b>	<b>Units</b>	<b>Effluent Limitations</b>	<b>Basis</b>
BOD <sub>5</sub>	mg/L	AMEL 10 AWEL 15	TTC
BOD <sub>5</sub>	% removal	Average Monthly greater than or equal to 85	CFR
pH	standard units	Instantaneous Max 8.5 Instantaneous Min 6.5	BP; PB
TSS	mg/L	AMEL 10 AWEL 15	TTC
TSS	% removal	Average Monthly greater than or equal to 85	CFR
Ammonia Nitrogen, Total (as N) (1 May – 31 October)	mg/L	AMEL 0.51 AWEL 1.8	NAWQC
Ammonia Nitrogen, Total (as N) (1 May – 31 October)	lbs/day	AMEL 16 AWEL 55	NAWQC
Ammonia Nitrogen, Total (as N) (1 November – 30 April)	mg/L	AMEL 1.1 AWEL 3.3	NAWQC
Ammonia Nitrogen, Total (as N) (1 November – 30 April)	lbs/day	AMEL 34 AWEL 100	NAWQC
Electrical Conductivity @ 25°Celsius	µmhos/cm	AAEL 1,300	PB; SECMCL
Mercury, Total	lbs/year	0.015	PB
Nitrate plus Nitrite (as N)	mg/L	AMEL 10 AWEL 15	MCL
Total Coliform Organisms	MPN/100m L	2.2 as 7-day median; 23 more than once in any 30-day period; 240 at any time	Title 22

Parameter	Units	Effluent Limitations	Basis
Acute Toxicity	% survival	70% minimum for any one bioassay; 90% median for any three consecutive bioassays	BP
Chronic Toxicity	TUc	1 TUc	BP

**Table F-12 Notes:**

1. **Abbreviations used in this table are as follows:**

**TTC** – Based on tertiary treatment capability. These effluent limitations reflect the capability of a properly operated tertiary treatment plant.

**CFR** – Based on secondary treatment standards contained in 40 CFR part 133.

**BP** – Based on water quality objectives contained in the Basin Plan.

**PB** – Based on treatment plant performance.

**NAWQC** – Based on U.S. EPA’s National Ambient Water Quality Criteria for the protection of freshwater aquatic life.

**SECMCL** – Based on the Secondary Maximum Contaminant Level.

**TMDL** – Based on impaired water body CWA section 303(d) listing and developing TMDL for mercury.

**MCL** – Based on the Primary Maximum Contaminant Level.

**Title 22** – Based on State Water Board Division of Drinking Water Reclamation Criteria, CCR, Division 4, Chapter 3 (Title 22).

2. **Mass limits** are based on average dry weather flow of 3.6 MGD.

3. **Electrical Conductivity @ 25 degrees Celsius.** Effluent limitation is applied as a calendar year annual average effluent limitation.

4. **Total Mercury.** Effluent limitation is applied as a calendar year average annual total mass load.

**E. Interim Effluent Limitations**

The State Water Board’s Resolution 2008-0025 “Policy for Compliance Schedules in National Pollutant Discharge Elimination System Permits” (Compliance Schedule Policy) requires the Central Valley Water Board to establish interim numeric effluent limitations in this Order for compliance schedules longer than 1 year. As discussed in section VI.B.7 of this Fact Sheet, the Central Valley Water Board is approving compliance schedules longer than 1 year for chronic WET. The Compliance Schedule Policy requires that interim effluent limitations be based on current Facility performance or existing permit limitations, whichever is more stringent.

1. **Chronic WET**

a. **Compliance Schedule.** The Discharger has complied with the application requirements in paragraph 4 of the State Water Board’s Compliance Schedule Policy, and the Discharger’s application demonstrates the need for additional time to implement actions to comply with the final effluent

limitation for chronic WET. Therefore, a compliance schedule for compliance with the final effluent limitation for chronic WET is established in this Order.

A compliance schedule is necessary because the Discharger must implement actions to comply with the final effluent limitation for chronic WET.

The Discharger has made diligent efforts to quantify chronic WET in the discharge and the sources of chronic WET in the waste stream. The Discharger conducted quarterly chronic WET monitoring during the term of Order R5-2014-0152.

The compliance schedule is as short as possible. An interim performance-based limitation has been included in this Order and was determined as described in section IV.E.1.b, below. The interim effluent limitation for chronic WET is in effect until the final effluent limitation takes effect on 1 April 2028. The interim numeric effluent limitation for chronic WET and source control measures will result in the highest discharge quality that can reasonably be achieved until final compliance is attained.

- b. **Interim Requirements.** The Compliance Schedule Policy requires the Central Valley Water Board to establish interim requirements and dates for their achievement in the NPDES permit. Interim numeric effluent limitations are required for a compliance schedule longer than 1 year. Interim effluent limitations must be based on current treatment plant performance or previous final permit limitations, whichever is more stringent. When feasible, interim limitations must correspond with final permit effluent limitations with respect to averaging bases (e.g., AMEL, MDEL, AWEL, etc.) for effluent limitations for which compliance protection is intended.
  - i. **Monitoring Requirements.** The Discharger shall perform quarterly chronic toxicity testing, concurrent with effluent ammonia sampling.
  - ii. **Chronic WET Interim Effluent Limitation.** The interim effluent limitation for chronic WET is based on Facility performance. Based on quarterly chronic WET testing conducted over the term of Order R5 2014-0152, the maximum observed result was greater than 8 TUc (as 100/NOEC) and a percent effect of 21.65 percent at 100 percent effluent. The Central Valley Water Board has established an interim effluent limitation for chronic WET of 16 TUc (as 100/NOEC) and a percent effect of 25 percent at 6.25 percent effluent.
  - iii. **Toxicity Reduction Evaluation (TRE) Requirements.** The Special Provision in section VI.C.2.a of the Order requires the Discharger to investigate the causes of and identify corrective actions to reduce or eliminate effluent toxicity.

The Central Valley Water Board finds that the Discharger can undertake source control and treatment plant measures to maintain compliance with the interim limitations included in this Order. Interim limitations are established when compliance with final effluent limitations cannot be achieved by the existing discharge. Discharge of constituents in concentrations in excess of the final effluent limitations, but in compliance with the interim effluent limitations, can significantly degrade water quality and adversely affect the beneficial uses of the receiving stream on a long-term basis. The interim limitations, however, establish an enforceable ceiling concentration until compliance with the final effluent limitations can be achieved.

**F. Land Discharge Specifications – Not Applicable**

**G. Recycling Specifications – Not Applicable**

**V. RATIONALE FOR RECEIVING WATER LIMITATIONS**

**A. Surface Water**

1. CWA section 303(a-c), requires states to adopt water quality standards, including criteria where they are necessary to protect beneficial uses. The Central Valley Water Board adopted water quality criteria as water quality objectives in the Basin Plan. The Basin Plan states that “[t]he numerical and narrative water quality objectives define the least stringent standards that the Regional Water Board will apply to regional waters in order to protect the beneficial uses.” The Basin Plan includes numeric and narrative water quality objectives for various beneficial uses and water bodies. This Order contains receiving surface water limitations based on the Basin Plan numerical and narrative water quality objectives for bacteria, biostimulatory substances, chemical constituents, color, dissolved oxygen, floating material, oil and grease, pH, pesticides, radioactivity, suspended sediment, settleable substances, suspended material, tastes and odors, temperature, toxicity, and turbidity.
2. The receiving water limitations in this Order are applicable to both the South Fork of Putah Creek and the Arboretum Waterway. However, because the Arboretum Waterway is an isolated stormwater basin with several influences, this Order does not require receiving water monitoring for pH, temperature, and turbidity in the Arboretum Waterway for compliance purposes. However, as discussed further in section VII.D of this Fact Sheet, receiving water monitoring is required in the South Fork of Putah Creek upstream and downstream of the confluence with the Arboretum Waterway (which includes discharges from Discharge Point 002) and Discharge Point 001 to determine the impact of both discharges to the receiving water.

**B. Groundwater**

1. The beneficial uses of the underlying groundwater are municipal and domestic supply, industrial service supply, industrial process supply, and agricultural supply.
2. Basin Plan water quality objectives include narrative objectives for chemical constituents, tastes and odors, and toxicity of groundwater. The toxicity objective requires that groundwater be maintained free of toxic substances in concentrations that produce detrimental physiological responses in humans, plants, animals, or aquatic life. The chemical constituent objective states groundwater shall not contain chemical constituents in concentrations that adversely affect any beneficial use. The tastes and odors objective prohibit taste- or odor-producing substances in concentrations that cause nuisance or adversely affect beneficial uses. The Basin Plan also establishes numerical water quality objectives for chemical constituents and radioactivity in groundwaters designated as municipal supply. These include, at a minimum, compliance with MCLs in Title 22 of the CCR. The bacteria objective prohibits coliform organisms at or above 2.2 MPN/100 mL. The Basin Plan requires the application of the most stringent objective necessary to ensure that waters do not contain chemical constituents, toxic substances, radionuclides, taste- or odor-producing substances, or bacteria in concentrations that adversely affect municipal or domestic supply, agricultural supply, industrial supply or some other beneficial use.
3. Groundwater limitations are required to protect the beneficial uses of the underlying groundwater.

**VI. RATIONALE FOR PROVISIONS**

**A. Standard Provisions**

Standard Provisions, which apply to all NPDES permits in accordance with 40 C.F.R. section 122.41, and additional conditions applicable to specified categories of permits in accordance with 40 C.F.R. section 122.42, are provided in Attachment D. The discharger must comply with all standard provisions and with those additional conditions that are applicable under section 122.42.

Sections 122.41(a)(1) and (b) through (n) of 40 C.F.R. establish conditions that apply to all state issued NPDES permits. These conditions must be incorporated into the permits either expressly or by reference. If incorporated by reference, a specific citation to the regulations must be included in the Order. Section 123.25(a)(12) of 40 C.F.R. allows the state to omit or modify conditions to impose more stringent requirements. In accordance with 40 C.F.R. section 123.25, this Order omits federal conditions that address enforcement authority specified in 40 C.F.R. sections 122.41(j)(5) and (k)(2) because the enforcement authority under the Water Code is more stringent. In lieu of these conditions, this Order incorporates by reference Water Code section 13387(e).

## B. Special Provisions

### 1. Reopener Provisions

- a. **Mercury.** This provision allows the Central Valley Water Board to reopen this Order in the event mercury is found to be causing toxicity based on acute or chronic toxicity test results, or if a TMDL program is adopted. In addition, this Order may be reopened if the Central Valley Water Board determines that a mercury offset program is feasible for dischargers subject to NPDES permits.
- b. **Whole Effluent Toxicity.** This Order requires the Discharger to investigate the causes of, and identify corrective actions to reduce or eliminate, effluent toxicity through a site-specific TRE. This Order may be reopened to include a revised chronic toxicity limitation, a revised acute toxicity limitation, and/or a limitation for a specific toxicant identified in the TRE.
- c. **Ultraviolet (UV) Disinfection Operating Specifications.** The UV operating specifications in this Order are based on UV guidelines developed by the National Water Research Institute and American Water Works Association Research Foundation titled, "Ultraviolet Disinfection Guidelines for Drinking Water and Water Reuse", and the recommendations of the Division of Drinking Water's from results of a spot-check bioassay included with the letter dated 14 June 2019. The Discharger is planning to replace the current UV disinfection system in late 2021 because the existing system has reached the end of its useful life. If the Discharger conducts a site-specific UV engineering study on the new UV disinfection system that identifies site-specific UV operating specifications that will achieve the virus inactivation equivalent to Title 22 disinfected tertiary recycled water, this Order may be reopened to modify the UV operating specifications.
- d. **Central Valley Salinity Alternatives for Long-Term Sustainability (CV-SALTS).** On 17 January 2020, certain Basin Plan Amendments to incorporate new strategies for addressing ongoing salt and nitrate accumulation in the Central Valley became effective. Other provisions subject to U.S. EPA approval became effective on 2 November 2020, when approved by U.S. EPA. As the Central Valley Water Board moves forward to implement those provisions that are now in effect, this Order may be amended or modified to incorporate new or modified requirements necessary for implementation of the Basin Plan Amendments. More information regarding these Amendments can be found at the following link:

[Central Valley Salinity Alternatives for Long-Term Sustainability \(CVSALTS\) web page:](https://www.waterboards.ca.gov/centralvalley/water_issues/salinity/)

([https://www.waterboards.ca.gov/centralvalley/water\\_issues/salinity/](https://www.waterboards.ca.gov/centralvalley/water_issues/salinity/))

## 2. Special Studies and Additional Monitoring Requirements

- a. **Chronic WET Requirements.** The Basin Plan contains a narrative toxicity objective that states, “All waters shall be maintained free of toxic substances in concentrations that produce detrimental physiological responses in human, plant, animal, or aquatic life.” (Basin Plan at section 3.1.20). Based on whole effluent chronic toxicity testing performed by the Discharger from August 2016 through September 2019, the discharge has reasonable potential to cause or contribute to an instream excursion above of the Basin Plan’s narrative toxicity objective.

The MRP of this Order requires chronic WET monitoring to demonstrate compliance with the numeric chronic toxicity effluent limitations. If the discharge exceeds the chronic toxicity monitoring trigger specified in section VI.C.2 of the Order, this provision requires the Discharger either participate in an approved Toxicity Evaluation Study (TES) or conduct a site-specific TRE.

A TES may be conducted in lieu of a TRE if the percent effect at 100 percent effluent is less than or equal to 50 percent. Determining the cause of toxicity can be challenging when the toxicity signal is low. Several Central Valley facilities with similar treatment systems have been experiencing intermittent low-level toxicity. The dischargers have not been successful identifying the cause of the toxicity because of the low toxicity signal and the intermittent nature of the toxicity. Due to these challenges, the Central Valley Clean Water Association (CVCWA), in collaboration with staff from the Central Valley Water Board, has initiated a Special Study to Investigate Low Level Toxicity Indications (Group Toxicity Study). This Order allows the Discharger to participate in an approved TES, which may be conducted individually or as part of a coordinated group effort with other similar dischargers that are exhibiting toxicity. Although the current CVCWA Group Toxicity Study is related to low-level toxicity, participation in an approved TES is not limited to only low-level toxicity issues.

See the WET Monitoring Flow Chart (Figure F-3), below, for further clarification of the decision points for determining the need for TES/TRE initiation.

**TRE Guidance.** The Discharger is required to prepare a TRE Work Plan in accordance with U.S. EPA guidance. Numerous guidance documents are available, as identified below:

- i. Toxicity Reduction Evaluation Guidance for Municipal Wastewater Treatment Plants, EPA/833-B-99/002, August 1999.
- ii. Generalized Methodology for Conducting Industrial Toxicity Reduction Evaluations (TREs), EPA/600/2-88/070, April 1989.

- iii. Methods for Aquatic Toxicity Identification Evaluations: Phase I Toxicity Characterization Procedures, Second Edition, EPA 600/6-91/003, February 1991.
- iv. Toxicity Identification Evaluation: Characterization of Chronically Toxic Effluents, Phase I, EPA/600/6-91/005F, May 1992.
- v. Methods for Aquatic Toxicity Identification Evaluations: Phase II Toxicity Identification Procedures for Samples Exhibiting Acute and Chronic Toxicity, Second Edition, EPA/600/R-92/080, September 1993.
- vi. Methods for Aquatic Toxicity Identification Evaluations: Phase III Toxicity Confirmation Procedures for Samples Exhibiting Acute and Chronic Toxicity, Second Edition, EPA 600/R-92/081, September 1993.
- vii. Methods for Measuring the Acute Toxicity of Effluents and Receiving Waters to Freshwater and Marine Organisms, Fifth Edition, EPA-821-R-02-012, October 2002.
- viii. Short-term Methods for Estimating the Chronic Toxicity of Effluents and Receiving Waters to Freshwater Organisms, Fourth Edition, EPA-821-R-02-013, October 2002.
- ix. Technical Support Document for Water Quality-based Toxics Control, EPA/505/2-90-001, March 1991.



**Figure F-3: WET Accelerated Monitoring Flow Chart**

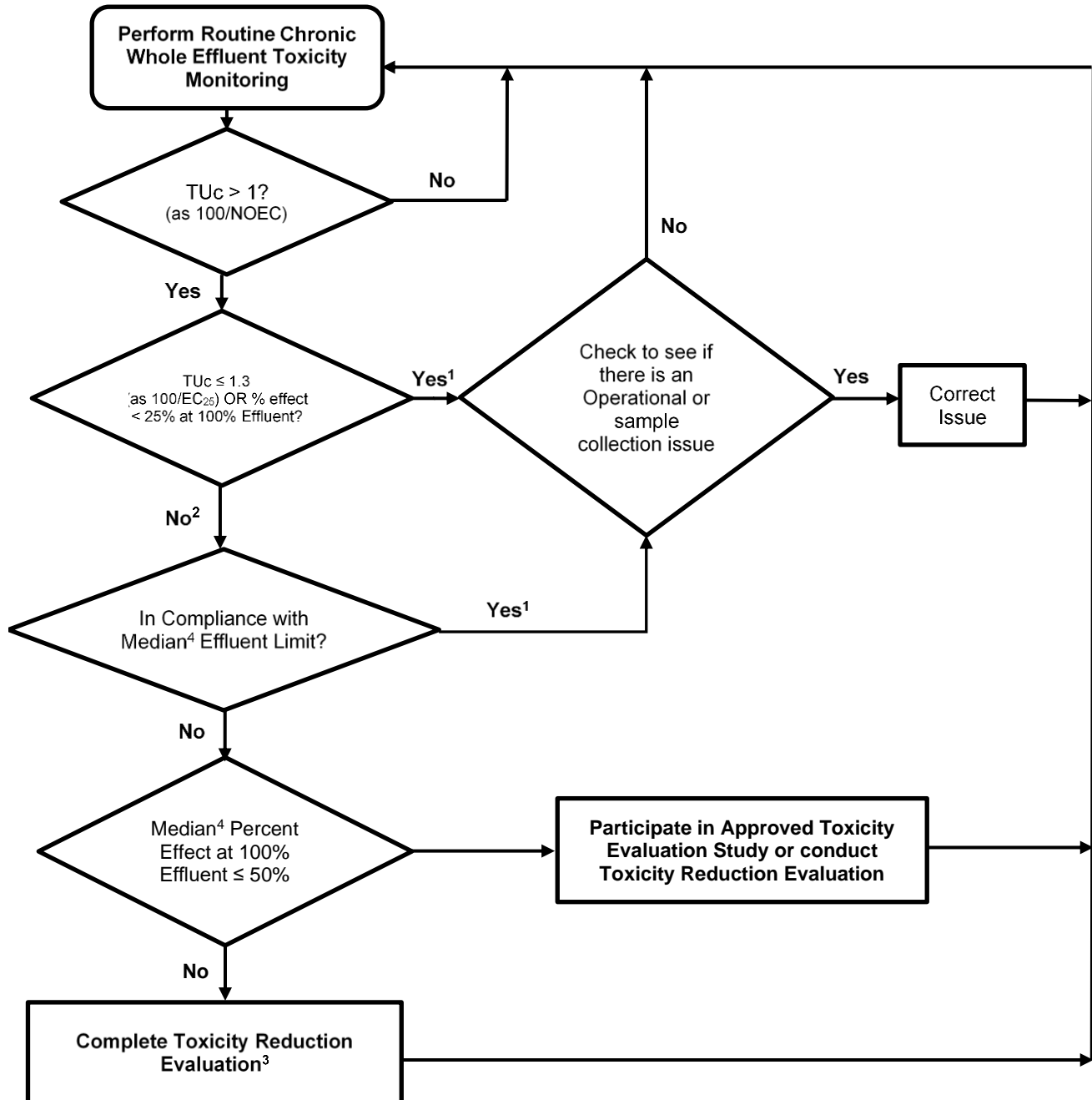

**Figure F-3 Notes:**

1. The Discharger may participate in an approved TES if the discharge has exceeded the chronic toxicity effluent limitations twice or more in the past 12-month period and the cause is not identified and/or addressed.
2. The Discharger may elect to take additional samples to determine the 3-sample median. The samples shall be collected at least one week apart and the final sample shall be within 6 weeks of the initial sample exhibiting toxicity.

3. The Discharger may participate in an approved TES instead of a TRE if the Discharger has conducted a TRE within the past 12 months and has been unsuccessful in identifying the toxicant.
4. See Compliance Determination section VII.J for procedures for calculating 6-week median.

### 3. Best Management Practices and Pollution Prevention

- a. **Salinity Evaluation and Minimization Plan.** A Salinity Evaluation and Minimization Plan for salinity is required to be maintained in this Order to ensure adequate measures are developed and implemented by the Discharger to reduce the discharge of salinity to the South Fork of Putah Creek.

### 4. Construction, Operation, and Maintenance Specifications

- a. **Filtration System Operating Specifications.** Turbidity is included as an operational specification as an indicator of the effectiveness of the filtration system for providing adequate disinfection. The tertiary treatment process utilized at this Facility is capable of reliably meeting a turbidity limitation of 2 nephelometric turbidity units (NTU) as a daily average. Failure of the treatment system such that virus removal is impaired would normally result in increased particles in the effluent, which result in higher effluent turbidity and could impact UV dosage. Turbidity has a major advantage for monitoring filter performance, allowing immediate detection of filter failure and rapid corrective action. The operational specification requires that turbidity prior to disinfection shall not exceed 2 NTU as a daily average; 5 NTU, more than 5 percent of the time within a 24-hour period, and an instantaneous maximum of 10 NTU.
- b. **Ultraviolet (UV) Disinfection System Operating Specifications.** This Order requires that wastewater shall be oxidized, coagulated, filtered, and adequately disinfected pursuant to the DDW reclamation criteria, CCR, Title 22, division 4, chapter 3, (Title 22), or equivalent. To ensure that the UV disinfection system is operated to achieve the required pathogen removal, this Order includes effluent limits for total coliform organisms, filtration system operating specifications, and UV disinfection system operating specifications. Compliance with total coliform effluent limits alone does not ensure that pathogens in the municipal wastewater have been deactivated by the UV disinfection system. Compliance with the effluent limits and the filtration system and UV disinfection operating specifications demonstrates compliance with the equivalency to Title 22 disinfection requirement.

The NWRI guidelines include UV operating specifications for compliance with Title 22. For water recycling in accordance with Title 22, the UV system shall be an approved system included in the Treatment Technology Report for Recycled Water, December 2009 (or a later version, as applicable) published by the DDW. The UV system shall also

conform to all requirements and operating specifications of the NWRI guidelines. A memorandum dated 1 November 2004 issued by DDW to Regional Water Board executive offices recommended that provisions be included in permits for water recycling treatment plants employing UV disinfection requiring dischargers to establish fixed cleaning frequency of lamp sleeves, as well as, include provisions that specify minimum delivered UV dose that must be maintained (per the NWRI Guidelines).

The DDW, in a letter dated 14 June 2019, based on the spot-check bioassay test of the UV disinfection system provided the specifications for the Facility. Therefore, in lieu of the UV dose and transmittance requirements of the NWRI Guidelines, the UV disinfection system must be operated in accordance with the operating specifications outlined DDW's 14 June 2019 letter, which assures adequate disinfection to provide virus inactivation equivalent to Title 22 Disinfected Tertiary Recycled Water. The following UV disinfection operating specifications will be evaluated to determine compliance with this requirement:

- i. **UV Dose.** The minimum hourly average UV dose in the UV reactor shall be 127 millijoules per square centimeter ( $\text{mJ}/\text{cm}^2$ ).
  - ii. **UV Transmittance.** The minimum hourly average UV transmittance (at 254 nanometers) in the wastewater measured at UVS-001 shall not fall below 28 percent.
  - iii. The lamp sleeves and cleaning system components must be visually inspected per the manufacturer's operations manual for physical wear (scoring, solarization, seal leaks, cleaning fluid levels, etc.) and to check the efficacy of the cleaning system.
  - iv. The lamp sleeves must be cleaned periodically as necessary to meet the UV dose requirements.
  - v. Lamps must be replaced per the manufacturer's operations manual, or sooner, if there are indications the lamps are failing to provide adequate disinfection. Lamp age and lamp replacement records must be maintained.
- c. **Solids Stabilization Basins Operating Requirements.**
- i. The treatment facilities, which include two solids stabilization basins that may also provide temporary emergency storage, shall be designed, constructed, operated, and maintained to prevent inundation or washout due to floods with a 100-year return frequency.
  - ii. Public contact with wastewater shall be precluded through such means as fences, signs, and other acceptable alternatives.
  - iii. Ponds shall be managed to prevent breeding of mosquitoes. In particular,

- (a) An erosion control program should assure that small coves and irregularities are not created around the perimeter of the water surface.
  - (b) Weeds shall be minimized.
  - (c) Dead algae, vegetation, and debris shall not accumulate on the water surface.
- iv. Freeboard in the emergency storage pond shall never be less than 2 feet (measured vertically to the lowest point of overflow), except if lesser freeboard does not threaten the integrity of the pond, no overflow of the pond occurs, and lesser freeboard is due to direct precipitation or storm water runoff occurring as a result of annual precipitation with greater than a 100-year recurrence interval, or a storm event with an intensity greater than a 25-year, 24-hour storm event.
  - v. Ponds shall have sufficient capacity to accommodate allowable wastewater flow and design seasonal precipitation and ancillary inflow and infiltration during the non-irrigation season. Design seasonal precipitation shall be based on total annual precipitation using a return period of 100 years, distributed monthly in accordance with historical rainfall patterns. Freeboard shall never be less than 2 feet (measured vertically to the lowest point of overflow).
  - vi. Prior to the onset of the rainy season of each year, available pond storage capacity shall at least equal the volume necessary to comply with section VI.C.4.c.v, above.
  - vii. Objectional odors originating at this Facility shall not be perceivable beyond the limits of the wastewater treatment plant.

**5. Special Provisions for Publicly-Owned Treatment Works (POTWs)**

- a. **Sludge/Biosolids Treatment.** Sludge in this Order means the solid, semisolid, and liquid residues removed during primary, secondary, or advanced wastewater treatment processes. Solid waste refers to grit and screening material generated during preliminary treatment. Residual sludge means sludge that will not be subject to further treatment at the wastewater treatment plant. Biosolids refer to sludge that has been treated and tested and shown to be capable of being beneficially and legally used pursuant to federal and state regulations as a soil amendment for agricultural, silvicultural, horticultural, and land reclamation activities as specified under 40 C.F.R. part 503. This Order does not regulate offsite use or disposal of biosolids, which are regulated instead under 40 C.F.R. part 503; administered by U.S. EPA. The Sludge/Biosolids Treatment or Discharge Specifications in this Order implement the California Water Code to ensure sludge/biosolids are

properly handled onsite to prevent nuisance, protect public health, and protect groundwater quality.

- b. **Resource Recovery from Anaerobically Digestible Material.** Some POTWs choose to accept organic material such as food waste, fats, oils, and grease into their anaerobic digesters for co-digestion to increase production of methane and other biogases for energy production and to prevent such materials from being discharged into the collection system, which could cause sanitary sewer overflows. The California Department of Resources Recycling and Recovery has proposed an exemption from requiring Process Facility/Transfer Station permits where this activity is regulated under waste discharge requirements or NPDES permits. The proposed exemption is restricted to anaerobically digestible material that has been prescreened, slurried, and processed/conveyed in a closed system to be co-digested with regular POTW sludge. The proposed exemption requires that a POTW develop Standard Operating Procedures for the proper handling, processing, tracking, and management of the anaerobically digestible material before it is received by the POTW.

Standard Operating Procedures are required for POTWs that accept hauled food waste, fats, oil, and grease for injection into anaerobic digesters. The development and implementation of Standard Operating Procedures for management of these materials is intended to allow the California Department of Resources Recycling and Recovery to exempt this activity from separate and redundant permitting programs. If the POTW does not accept food waste, fats, oil, or grease for resource recovery purposes, it is not required to develop and implement Standard Operating Procedures.

The Discharger currently does not accept hauled-in ADM for direct injection into its anaerobic digester for co-digestion. However, if the Discharger proposes to receive hauled-in ADM for injection into its anaerobic digester for co-digestion, this provision requires the Discharger to notify the Central Valley Water Board and develop and implement SOP's for this activity prior to initiation of the hauling. The requirements of the SOP's are discussed in section VI.C.5.b.

## 6. Other Special Provisions

- a. **Title 22, or Equivalent, Disinfection Requirements.** Wastewater shall be oxidized, coagulated, filtered, and adequately disinfected pursuant to the State Water Board, Division of Drinking Water reclamation criteria, CCR, Title 22, division 4, chapter 3, (Title 22), or equivalent.

## 7. Compliance Schedules

In general, an NPDES permit must include final effluent limitations that are consistent with CWA section 301 and with 40 C.F.R. section 122.44(d). There are exceptions to this general rule. The State Water Board's Resolution 2008-

0025 "Policy for Compliance Schedules in National Pollutant Discharge Elimination System Permits" (Compliance Schedule Policy) allows compliance schedules for new, revised, or newly interpreted water quality objectives or criteria, or in accordance with a TMDL. All compliance schedules must be as short as possible, and may not exceed 10 years from the effective date of the adoption, revision, or new interpretation of the applicable water quality objective or criterion, unless a TMDL allows a longer schedule. Where a compliance schedule for a final effluent limitation exceeds one year, the Order must include interim numeric effluent limitations for that constituent or parameter, interim requirements and dates toward achieving compliance, and compliance reporting within 14 days after each interim date. The Order may also include interim requirements to control the pollutant, such as pollutant minimization and source control measures.

In accordance with the Compliance Schedule Policy and 40 C.F.R. section 122.47, a discharger who seeks a compliance schedule must demonstrate additional time is necessary to implement actions to comply with a more stringent permit limitation. The Discharger must provide the following documentation as part of the application requirements:

- a. Diligent efforts have been made to quantify pollutant levels in the discharge and the sources of the pollutant in the waste stream, and the results of those efforts;
- b. Source control efforts are currently underway or completed, including compliance with any pollution prevention programs that have been established;
- c. A proposed schedule for additional source control measures or waste treatment;
- d. Data demonstrating current Facility performance to compare against existing permit effluent limits, as necessary to determine which is the more stringent interim, permit effluent limit to apply if a schedule of compliance is granted;
- e. The highest discharge quality that can reasonably be achieved until final compliance is attained;
- f. The proposed compliance schedule is as short as possible, given the type of facilities being constructed or programs being implemented, and industry experience with the time typically required to construct similar facilities or implement similar programs; and
- g. Additional information and analyses to be determined by the Regional Water Board on a case-by-case basis.

Based on information submitted with the Notice of Intent, SMR's, and other miscellaneous submittals, it has been demonstrated to the satisfaction of the Central Valley Water Board that the Discharger needs time to implement actions to comply with the final effluent limitations for the chronic WET effluent limitation.

**Chronic Whole Effluent Toxicity.** The Discharger submitted a request and justification, dated 20 October 2020, for a compliance schedule for chronic WET. The compliance schedule justification included all items specified in subsections (a) through (g), above. This Order establishes a compliance schedule for the final WQBEL's for chronic WET, with compliance required by 1 April 2028.

## VII. RATIONALE FOR MONITORING AND REPORTING REQUIREMENTS

CWA section 308 and 40 C.F.R. sections 122.41(h), (j)-(l), 122.44(i), and 122.48 require that all NPDES permits specify monitoring and reporting requirements. Water Code sections 13267 and 13383 also authorize the Central Valley Water Board to establish monitoring, inspection, entry, reporting, and recordkeeping requirements.

Water Code section 13176, subdivision (a)(1) requires that laboratory analyses shall be performed by laboratories accredited by the State Water Resources Control Board, Division of Drinking Water, which accredits laboratories through its Environmental Laboratory Accreditation Program (ELAP). Data generated using field tests are exempt from this requirement pursuant to Water Code Section 13176, subdivision (a)(2).

The MRP (Attachment E) of this Order establishes monitoring, reporting, and recordkeeping requirements that implement federal and state requirements. The following provides the rationale for the monitoring and reporting requirements contained in the MRP for this facility.

### A. Influent Monitoring

1. Influent monitoring is required to collect data on the characteristics of the wastewater and to assess compliance with effluent limitations (e.g., BOD<sub>5</sub> and TSS reduction requirements). The monitoring frequency for flow (continuous) had been retained from Order R5-2014-0152.
2. Order R5-2014-0152 required regular influent monitoring for BOD<sub>5</sub> (3/week), TSS (3/week), and electrical conductivity (monthly). This Order reduces the regular influent monitoring for BOD<sub>5</sub> and TSS to twice per week, and for electrical conductivity to once per quarter. The Central Valley Water Board finds that the reduced frequency is sufficient to characterize the influent.

### B. Effluent Monitoring

1. Pursuant to the requirements of 40 C.F.R. section 122.44(i)(2) effluent monitoring is required for all constituents with effluent limitations. Effluent monitoring is necessary to assess compliance with effluent limitations, assess the effectiveness of the treatment process, and to assess the impacts of the discharge on the receiving stream and groundwater.
2. Effluent monitoring frequencies and sample types for flow (continuous), electrical conductivity (monthly), hardness (monthly), nitrate nitrogen (monthly),

nitrite nitrogen (monthly), pH (daily), temperature (daily), turbidity (continuous), and mercury (annually) have been retained from Order R5-2014-0152 to determine compliance with effluent limitations for these parameters.

3. Monitoring data collected over the previous permit term for selenium did not demonstrate reasonable potential to exceed water quality objectives/criteria. In addition, chlorine is no longer used at the Facility and the effluent limitations for total residual chlorine have been removed in this Order. Thus, specific effluent monitoring requirements for these parameters have not been retained from Order R5-2014-0152.
4. Order R5-2014-0152 required regular effluent monitoring for BOD<sub>5</sub> (3/week), TSS (3/week), and ammonia nitrogen (3/week). This Order reduces the regular effluent monitoring for BOD<sub>5</sub> and TSS to twice per week, and for ammonia nitrogen to once per week. The Central Valley Water Board finds that the reduced frequency is sufficient to characterize the effluent.
5. Order R5-2014-0152 required regular effluent monitoring for TDS. This Order includes regular effluent monitoring of electrical conductivity. Therefore, regular effluent monitoring of TDS is not necessary to adequately evaluate the effluent for salinity. Effluent monitoring for TDS is required during the characterization monitoring. The Central Valley Water Board finds that removing regular effluent monitoring for TDS is not necessary to characterize the effluent.
6. Order R5-2014-0152 did not require regular effluent monitoring for dissolved oxygen. This Order includes regular effluent monthly monitoring for dissolved oxygen. The Central Valley Water Board finds that the addition of regular monitoring for dissolved oxygen is necessary to characterize the effluent.
7. Order R5-2014-0152 did not require regular effluent monitoring for dissolved organic carbon. This Order includes quarterly effluent monitoring for dissolved organic carbon to calculate site-specific freshwater aluminum criteria in accordance with the 2018 U.S. EPA NAWQC for aluminum in freshwater for the next permit renewal.
8. **Pyrethroid Pesticides Monitoring.** A Basin Plan Amendment and TMDL for the Control of Pyrethroid Pesticide Discharges in the Sacramento and San Joaquin River basins (Resolution R5-2017-0057) was approved by the Central Valley Water Board on 8 June 2017 and is now effective. The Pyrethroids Control Program established by Resolution R5-2017-0057 requires monitoring by domestic and municipal wastewater dischargers discharging at least 1 MGD for the concentrations of pyrethroid pesticides, total and dissolved organic carbon in the water column, and water column toxicity testing. Monitoring is required to evaluate the potential impacts of discharges of pyrethroid pesticides to receiving waters.



**C. Whole Effluent Toxicity Testing Requirements**

1. **Acute Toxicity.** Quarterly 96-hour bioassay testing is required to demonstrate compliance with the effluent limitations for acute toxicity.
2. **Chronic Toxicity.** Quarterly chronic whole effluent toxicity testing is required in order to demonstrate compliance with the numeric chronic toxicity effluent limitation.

**D. Receiving Water Monitoring**

**1. Surface Water**

- a. Receiving water monitoring is necessary to assess compliance with receiving water limitations and to assess the impacts of the discharge on the receiving stream.
- b. Regular monthly receiving water monitoring for electrical conductivity, hardness, and dissolved oxygen have been retained from Order R5-2014-0152 to determine compliance with receiving water limitations for these parameters.
- c. Regular receiving water monitoring for pH and temperature has been increased in this Order to once per week from once per month contained in Order R5-2014-0152 to increase the dataset for calculating the ammonia criteria for the next permit renewal.
- d. Monitoring data collected over the previous permit term for selenium did not demonstrate reasonable potential to exceed water quality objectives/criteria. Thus, quarterly receiving water monitoring requirements for selenium have not been retained from Order R5-2014-0152.
- e. This Order includes quarterly receiving water monitoring for dissolved organic carbon to calculate site-specific freshwater aluminum criteria in accordance with the 2018 U.S. EPA NAWQC for aluminum in freshwater for the next permit renewal.

**2. Groundwater**

- a. Groundwater monitoring data collected over the previous permit term shows that the sludge stabilization ponds and the sludge drying beds are not negatively impacting groundwater. The ponds are designed with a clay-liner and the drying beds are lined with asphalt. Thus, groundwater monitoring requirements have not been retained from Order R5-2014-0152.

**E. Other Monitoring Requirements**

**1. Biosolids Monitoring – Not Applicable**

**2. Water Supply Monitoring**

Quarterly water supply monitoring for electrical conductivity is retained and quarterly water supply monitoring for TDS has not been retained from Order R5-2014-0152. Monitoring of electrical conductivity is adequate to evaluate the municipal water supply.

**3. UV Disinfection System Monitoring**

UV system monitoring and reporting are required to ensure that the UV system is operated to adequately inactivate pathogens in the wastewater. UV disinfection system monitoring is imposed to achieve equivalency to requirements established by the DDW, and the NWRI, Guidelines. Monitoring frequency for total coliform organisms at monitoring location UVS-002 has been reduced from five times per week to three times per week. The Central Valley Water Board finds that the reduced frequency is sufficient to maintain proper operation of the disinfection system.

**4. Discharge Monitoring Report-Quality Assurance (DMR-QA) Study Program**

Under the authority of section 308 of the CWA (33 U.S.C. section 1318), U.S. EPA requires all dischargers under the NPDES Program to participate in the annual DMR-QA Study Program. The DMR-QA Study evaluates the analytical ability of laboratories that routinely perform or support self-monitoring analyses required by NPDES permits. There are two options to satisfy the requirements of the DMR-QA Study Program: (1) The Discharger can obtain and analyze a DMR-QA sample as part of the DMR-QA Study; or (2) Per the waiver issued by U.S.EPA to the State Water Board, the Discharger can submit the results of the most recent Water Pollution Performance Evaluation Study from their own laboratories or their contract laboratories. A Water Pollution Performance Evaluation Study is similar to the DMR-QA Study. Thus, it also evaluates a laboratory's ability to analyze wastewater samples to produce quality data that ensure the integrity of the NPDES Program. The Discharger shall submit annually the results of the DMR-QA Study or the results of the most recent Water Pollution Performance Evaluation Study to the State Water Board. The State Water Board's Quality Assurance Program Officer will send the DMR-QA Study results or the results of the most recent Water Pollution Performance Evaluation Study to U.S. EPA's DMR-QA Coordinator and Quality Assurance Manager.

## VIII. PUBLIC PARTICIPATION

The Central Valley Water Board has considered the issuance of WDRs that will serve as an NPDES permit for the University of California, Davis, Wastewater Treatment Plant. As a step in the WDR adoption process, the Central Valley Water Board staff has developed tentative WDRs and has encouraged public participation in the WDR adoption process.

### A. Notification of Interested Persons

The Central Valley Water Board notified the Discharger and interested agencies and persons of its intent to prescribe WDRs for the discharge and provided an opportunity to submit written comments and recommendations. Notification was provided through posting on the Central Valley Waterboard's website on **22 October 2020** and through posting by the Discharger at Davis City Hall on **22 October 2020** and at the Facility entrance on **23 October 2020**.

The public had access to the agenda and any changes in dates and locations through the [Central Valley Water Board's website](http://www.waterboards.ca.gov/centralvalley/board_info/meetings/) ([http://www.waterboards.ca.gov/centralvalley/board\\_info/meetings/](http://www.waterboards.ca.gov/centralvalley/board_info/meetings/))

### B. Written Comments

Interested persons were invited to submit written comments concerning tentative WDRs as provided through the notification process. Comments were due either in person or by mail to the Executive Office at the Central Valley Water Board at the address on the cover page of this Order.

To be fully responded to by staff and considered by the Central Valley Water Board, the written comments were due at the Central Valley Water Board office by 5:00 p.m. on **23 November 2020**.

### C. Public Hearing

The Central Valley Water Board held a public hearing on the tentative WDRs during its regular Board meeting on the following date and time and at the following location:

Date: **18 February 2021**  
Time: **8:30 a.m.**  
Location: **Online**

Interested persons were invited to attend. At the public hearing, the Central Valley Water Board heard testimony pertinent to the discharge, WDRs, and permit. For accuracy of the record, important testimony was requested in writing.

### D. Reconsideration of Waste Discharge Requirements

Any person aggrieved by this action of the Central Valley Water Board may petition the State Water board to review the action in accordance with Water Code section

13320 and California Code of Regulations, title 23, sections 2050 and following. The State Water Board must receive the petition by 5:00 p.m., within 30 calendar days of the date of adoption of this Order at the following address, except that if the thirtieth day following the date of this Order falls on a Saturday, Sunday, or state holiday, the petition must be received by the State Water Board by 5:00 p.m. on the next business day:

State Water Resources Control Board  
Office of Chief Counsel  
P.O. Box 100, 1001 I Street  
Sacramento, CA 95812-0100

Or by email to the [State Water Board](mailto:waterqualitypetitions@waterboards.ca.gov) (waterqualitypetitions@waterboards.ca.gov).

[Instructions on how to file a petition for review](http://www.waterboards.ca.gov/public_notices/petitions/water_quality/wqpetition_instructions.shtml)

([http://www.waterboards.ca.gov/public\\_notices/petitions/water\\_quality/wqpetition\\_instructions.shtml](http://www.waterboards.ca.gov/public_notices/petitions/water_quality/wqpetition_instructions.shtml)) are available on the Internet.

**E. Information and Copying**

The Report of Waste Discharge, other supporting documents, and comments received are on file and may be inspected at the address above at any time between 8:30 a.m. and 4:45 p.m., Monday through Friday. Copying of documents may be arranged through the Central Valley Water Board by calling (916) 464-3291.

**F. Register of Interested Persons**

Any person interested in being placed on the mailing list for information regarding the WDRs and NPDES permit should contact the Central Valley Water Board, reference this facility, and provide a name, address, and phone number.

**G. Additional Information**

Requests for additional information or questions regarding this order should be directed to David Kirn at (916) 464-4761.

**ATTACHMENT G – SUMMARY OF REASONABLE POTENTIAL ANALYSIS**

**Abbreviations used in this table:**

- MEC = Maximum Effluent Concentration
- B = Maximum Receiving Water Concentration or lowest detection level, if non-detect
- C = Criterion used for Reasonable Potential Analysis
- CMC = Criterion Maximum Concentration (CTR or NTR)
- CCC = Criterion Continuous Concentration (CTR or NTR)
- Water & Org = Human Health Criterion for Consumption of Water & Organisms (CTR or NTR)
- Org Only = Human Health Criterion for Consumption of Organisms Only (CTR or NTR)
- Basin Plan = Numeric Site-Specific Basin Plan Water Quality Objective
- MCL = Drinking Water Standards Maximum Contaminant Level
- NA = Not Available
- ND = Non-detect

General Note: All inorganic concentrations are given as a total recoverable.

Constituent	Units	MEC	B	C	CMC	CCC	Water & Org	Org. Only	Basin Plan	MCL	Reasonable Potential
Ammonia Nitrogen, Total (as N) (1 May – 31 October)	mg/L	1.40	0.05	0.61	5.62	0.61	--	--	--	--	Yes
Ammonia Nitrogen, Total (as N) (1 November – 30 April)	mg/L	1.15	0.05	1.20	7.28	1.20	--	--	--	--	Yes
Nitrate plus Nitrite (as N)	mg/L	18.7	--	10	--	--	--	--	--	10	Yes
Mercury, Total	µg/L	0.00041	ND	0.012	--	--	--	--	--	0.012	No

Constituent	Units	MEC	B	C	CMC	CCC	Water & Org	Org. Only	Basin Plan	MCL	Reasonable Potential
Electrical Conductivity at 25 Celsius	µmhos/cm	1091	542	1600	--	--	--	--	--	1600	No

**Table Notes:**

1. U.S. EPA NAWQC, Freshwater Aquatic Life Protection, 1-hour average.
2. U.S. EPA NAWQC, Freshwater Aquatic Life Protection, 30-day average.
3. See section IV.C.3 of the Fact Sheet for a discussion of the RPA results.
4. State Water Board Sport Fish Water Quality Objective for mercury.
5. Represents the maximum observed annual average concentration for comparison with the Secondary MCL.
6. Represents the Secondary MCL recommended level.

**ATTACHMENT H – CALCULATION OF WQBELS**

**Abbreviations used in this table:**

CV = Coefficient of Variation  
 MDEL = Maximum Daily Effluent Limitation  
 AMEL = Average Monthly Effluent Limitation  
 AWEL = Average Weekly Effluent Limitation

**HUMAN HEALTH WQBELS CALCULATIONS**

Parameter	Units	Criteria	Mean Background Concentration	Effluent CV	Dilution Factor	MDEL/AMEL Multiplier	AMEL Multiplier	AMEL	MDEL	AWEL
Nitrate plus Nitrite, Total (as N)	mg/L	10	1.38	0.41	--	--	1.36	10	--	15

**Table Notes:**

1. CV is established in accordance with section 1.4 of the SIP.
2. Criteria based on the Secondary MCL recommended level.

**ATTACHMENT H – CALCULATION OF WQBELS**

**Abbreviations used in the following table:**

- B = Maximum Receiving Water Concentration or lowest detection level, if non-detect
- CMC = Criterion Maximum Concentration (CTR or NTR) Criteria
- CCC = Criterion Continuous Concentration (CTR or NTR) Criteria
- CV = Coefficient of Variation (established in accordance with section 1.4 of the SIP)
- DF = Dilution Factor
- ECA = Effluent Concentration Allowance
- Eff = Effluent
- LTA = Aquatic Life Calculations – Long-Term Average
- Mult = Multiplier
- MDEL = Maximum Daily Effluent Limitation
- AMEL = Average Monthly Effluent Limitation
- MDEL = Maximum Daily Effluent Limitation
- AWEL = Average Weekly Effluent Limitation

**AQUATIC LIFE WQBELS CALCULATIONS**

Parameter	Units	CMC	CCC	B	Eff CV	CMC DF	CCC DF	ECA Mult <sub>acute</sub>	LTA <sub>acute</sub>	ECA Mult <sub>chronic</sub>	LTA <sub>chronic</sub>	AMEL Mult <sub>95</sub>	AWEL Mult	MDEL Mult <sub>99</sub>	AMEL	AWEL
Ammonia Nitrogen, Total (as N) (1 May – 31 October)	mg/L	5.62	0.61	0.05	1.40	--	--	0.15	0.86	0.58	0.35	1.47	4.94	--	0.51	1.8
Ammonia Nitrogen, Total (as N) (1 November – 30 April)	mg/L	7.28	1.2	0.05	1.20	--	--	0.17	1.26	0.62	0.74	1.40	4.45	--	1.1	3.3

**Table Notes:**

CV was established in accordance with section 1.4 of the SIP.

AMELs are calculated according to section 1.4 of the SIP using a 95th percentile occurrence probability.

AWELs are calculated according to section 1.4 of the SIP using a 98th percentile occurrence probability.