

**CALIFORNIA REGIONAL WATER QUALITY CONTROL BOARD  
LAHONTAN REGION**

**BOARD ORDER NO. R6-2026-0010  
WDID No. 6B142509005**

**WASTE DISCHARGE REQUIREMENTS  
FOR  
DEATH VALLEY NATIONAL PARK  
COW CREEK REVERSE OSMOSIS WATER TREATMENT FACILITY**

Inyo County

---

The California Regional Water Quality Control Board, Lahontan Region (Water Board) finds:

1. Facility

The Cow Creek Reverse Osmosis (RO) Water Treatment Plant (Facility) is owned and operated by the Death Valley National Park (Discharger). The Facility provides potable water to the Cow Creek area. A map of the Facility is included as Attachment B, which is made part of this Order.

2. Discharger

The Death Valley National Park (owner/operator) operates and owns the Facility and is referred to as the “Discharger.”

3. Facility Location

The Facility is located in Death Valley, Inyo County, as shown on Attachment A. The Facility is located in Section 35, Township 28 North, Range 1 East, San Bernardino Principal Meridian. The discharge area is located in Section 34, Township 28 North, Range 1 East, San Bernardino Baseline and Meridian. Both the Facility and discharge area are located within Parcel No. 041-180-06.

4. Reason for Action

This Order is being issued to regulate the discharge of RO concentrate from the Facility to the irrigation ditch system in the Cow Creek housing area. The Order reflects operational conditions and establishes the requirement to install an adequate groundwater monitoring network. All monitoring and reporting requirements are established in the Monitoring and Reporting Program (MRP) No. R6-2026-0010.

5. Order History

The Facility has been in operation since 2002. The discharge of RO concentrate has not been regulated by the Water Board prior to this Order. Historically, RO concentrate was discharged to the irrigation ditch system in the Cow Creek housing area from 2002 to 2013. In 2013, discharge to the irrigation system ceased and the RO concentrate was sent to the Furnace Creek Wastewater Treatment Plant for disposal. However, the wastewater plant was not authorized to accept the RO concentrate, and the high

volume of RO concentrate often exceeded the plant's treatment capacity. In 2024, the Discharger ceased discharge to the wastewater treatment plant and resumed discharging the RO concentrate to the irrigation ditch system in the Cow Creek housing area.

6. Facility Description

The Facility collects and treats spring water (source water) to provide potable water to various residences, businesses, and facilities within the Cow Creek area. The source water is Nevares Springs, located 8,700 feet to the east of the Facility. The Facility has the capacity to produce a maximum of 50,000 gallons per day (gpd) of potable water. Potable water is stored in a 350,000-gallon tank for distribution.

The Facility has the capacity to produce a maximum of 28,800 gpd of RO concentrate. Recorded flows of RO concentrate between April 2024 and June 2025 provide an average daily discharge of 15,334 gpd. RO concentrate is commingled with untreated source water via pipeline to the Cow Creek housing area. Once reaching the housing area, flow is diverted to two irrigation ditches. The north ditch is 473 feet long and the south ditch is 1,214 feet long, as shown in Attachment C.

7. RO Concentrate and Source Water Quality

Water quality data of RO concentrate prior to commingling with untreated source water was collected between February 2025 and August 2025. The following table is a summary of the highest concentration in milligrams per liter (mg/L) of RO concentrate data collected in 2025 compared to water quality data for the source water (Nevares Springs) collected in October 2023 and to the Maximum Contaminant Levels (MCLs). The source water exceeds MCLs for total dissolved solids (TDS) and fluoride, and the RO concentrate exceeds MCLs for TDS, fluoride, sulfate, and arsenic.

<b>Constituent</b>	<b>RO Concentrate Highest Concentration 2025 (mg/L)</b>	<b>Source Water October 2023 (mg/L)</b>	<b>MCL (mg/L)</b>
TDS	3,800	580	500
Nitrogen	Non-Detect	Non-Detect	None
Chloride	230	37	250
Fluoride	16	2.8	2
Sulfate	1,100	170	250
Calcium	300	41	None
Magnesium	138	20	None
Potassium	87	12	None
Sodium	1,000	150	None
Arsenic	0.041	0.0061	0.010

8. Authorized Discharge Locations

This Order authorizes the discharge of RO concentrate from the pipeline connecting the plant to the Cow Creek housing area north and south irrigation ditches. The volume of discharge is not sufficient to exceed the limits of the irrigation ditch system shown in Attachment C.

9. Land Uses

The Facility is located in the Cow Creek area within Death Valley in Inyo County. The Facility is located between State Route 190 (SR-190) to the west and Nevares Springs to the east. Potable water produced by the Facility serves administrative areas, school district facilities, campgrounds, and the housing area. The discharge of RO concentrate will assist with the irrigation of vegetation along the ditch system in the Cow Creek housing area.

10. Site Topography

The Cow Creek RO plant is located at an approximate elevation of about 190 feet below sea level. The topography is defined by its position within a desert basin surrounded by steep mountain ranges like the Funeral and Black Mountains. The terrain features broad alluvial fans, salt flats, and eroded badlands, shaped by tectonic activity and extreme arid conditions.

11. Climatology

Death Valley experiences an extreme arid desert climate characterized by high temperatures in the summer often exceeding 110 degrees Fahrenheit, average annual rainfall under 2 inches, and high evaporation rates. While precipitation is rare, occasional storms can trigger flash flooding, impacting local infrastructure and groundwater levels. The harsh environment accelerates material degradation and poses challenges for construction and maintenance, particularly for water and wastewater systems.

12. Geology / Soil Conditions

The Cow Creek area is characterized by young granular alluvium consisting of unconsolidated sandy gravel with silty fines. This type of soil provides a high percolation rate, calculated at 5.5 minutes per inch, which equates to 163 gallons per day per square foot. Nevares Springs is fed by groundwater from an underlying carbonate formation. Artesian pressure from this formation forces groundwater to the surface.

The irrigation ditches in the Cow Creek housing area show a build-up of travertine, a result of the naturally high mineral content in the spring water. These ditches serve as infiltration trenches, and under current conditions, all irrigation water is taken up by the vegetation or absorbed into the soil within the housing area.

13. Surface Water

The Facility is located in the Death Valley Hydrologic Area (HA No. 609.10) of the Amargosa Hydrologic Unit. The surface waters in Death Valley are primarily ephemeral, appearing during significant events such as flash floods. Most ephemeral flows are short lived, usually evaporating rapidly or by infiltration. The closest surface water that directly affects the Facility is Nevares Springs located 8,700 feet to the east. Nevares Springs flows year-round and is the source of potable water for the Cow Creek area.

14. Groundwater

The Facility is located in the Death Valley Groundwater Basin. Groundwater conditions at Cow Creek in Death Valley are variable and influenced by both natural features and recent climatic events. Near the Facility, groundwater typically flows from northeast to southwest from the Cow Creek area towards Furnace Creek based on the topographical gradient.

Geotechnical investigations in the vicinity of the proposed discharge points in the housing area revealed that groundwater was not encountered at depths of 13.4 feet and 30.5 feet below ground surface, indicating that the saturated zone is deeper than these levels. Geotechnical investigations conducted approximately 0.5 miles to the west (downgradient) of the irrigation ditch system revealed that groundwater was encountered at depths between 9.5 and 10.5 feet below the ground surface. These groundwater levels are not static and can fluctuate seasonally due to precipitation, runoff, and nearby spring activity.

Groundwater quality data from public water supply wells, located approximately four miles south of the Facility, indicate that some constituents of concern exceed the MCLs in the Death Valley Groundwater Basin. Specifically, TDS, fluoride, and arsenic have been detected in these public water supply wells at concentrations that exceed their respective MCL. There are no known anthropogenic sources near the public water supply wells. Therefore, these exceedances are thought to be attributed to natural water quality conditions related to geologic and hydrogeologic characteristics of the groundwater basin.

15. Lahontan Basin Plan

The Water Board adopted a *Water Quality Control Plan for the Lahontan Region* (Basin Plan), which became effective on March 31, 1995, which contains beneficial use designations and water quality objectives for waters of the Lahontan Region. Subsequent amendments to the Basin Plan were adopted. This Order implements the Basin Plan, as amended.

16. Receiving Waters and Beneficial Uses

The receiving waters are the groundwaters of the Death Valley Groundwater Basin (California Department of Water Resources, Basin No. 6-18). The beneficial uses for the groundwaters of Death Valley as set forth and defined in the Basin Plan are the following:

- a. Municipal and domestic supply (MUN),
- b. Agricultural supply (AGR),
- c. Freshwater replenishment (FRSH), and
- d. Wildlife Habitat (WILD).

17. Maintenance of High-Quality Waters in California, State Board Resolution 68-16, Degradation Analysis

State Water Resources Control Board, Resolution No. 68-16, "Statement of Policy with

Respect to Maintaining High Quality Waters in California,” also called the non-degradation policy, states:

1. *"Whenever the existing quality of water is better than the quality established in policies as of the date on which such policies become effective, such existing high quality will be maintained until it has been demonstrated to the State that a change will be consistent with the maximum benefit to the people of the State, will not unreasonably affect present and anticipated beneficial use of such water and will not result in water quality less than that prescribed in the policies.*
2. *Any activity which produces or may produce a waste ... and which discharges or proposes to discharge to existing high quality waters will be required to meet waste discharge requirements which will result in the best practicable treatment or control of the discharge necessary to assure that (a) pollution or nuisance will not occur, and (b) the highest water quality consistent with maximum benefit to the people of the State will be maintained."*

To the extent a discharge covered under this permit may be to high quality waters, this permit authorizes the degradation consistent with the Antidegradation Policy, and the Basin Plan as described below.

The RO process generates a concentrate waste stream, which is proposed to be blended with source water and discharged into two existing irrigation ditches (North and South) within the Cow Creek staff housing area. This reuse is intended to support irrigation of historic vegetation and reduce the burden on the Furnace Creek Wastewater Treatment Facility (WWTF). The WWTF had been receiving RO concentrate discharge for approximately 10 years. This practice ceased in 2024.

The primary constituents of concern (COCs) from Facility discharges are salts (total dissolved solids), sulfate, fluoride, and other minerals. The system is not introducing any additional COCs back into the natural environment, as the COCs generated during the RO process is from the source water itself. Furthermore, concentrate is blended with source water prior to discharge, reducing constituent concentrations. For reference, TDS was reduced from 3,400 mg/L in the RO concentrate to approximately 2,460 mg/L when applying a weighted average to blended source water and RO concentrate. Therefore, any degradation is expected to be limited.

The irrigation ditches are constructed in an upland area and designed to fully infiltrate the flow with no runoff expected beyond the housing area. A groundwater monitoring program will assess any potential impacts to groundwater, and the project will support beneficial reuse by irrigating vegetation and reduce reliance on discharging to the WWTF. The Cow Creek area is underlain by young granular alluvium with high percolation capacity (163 gallons per day per square foot). Downgradient of the Facility, there are no potable water sources or production wells making the Facility the only source for potable water in the area.

These waste discharge requirements will result in best practicable treatment and control measures to ensure water quality protection. Through the use of RO treatment to produce potable water for the region, contaminants such as fluoride and TDS will be

removed from the potable water supply. Other measures include blending with source water to dilute the RO concentrate's elevated constituents to acceptable levels.

These measures would ensure that pollution or nuisance will not occur, and that the discharge will not unreasonably affect beneficial uses of groundwater or result in water quality less than water quality objectives. Impacts to groundwater would be assessed with the installation of a groundwater monitoring well network.

Degradation of high-quality water that results from discharges regulated by this Order is consistent with the maximum benefit to the people of the State. The reverse osmosis system is required to provide potable water to the population surrounding the national park, which supports many national parks employees, as source water is unsuitable for potable uses with its high arsenic content. The use of RO is vital in providing potable water to park employees, and visitors of the Cow Creek area. Maintaining the potable water supply for the Death Valley National Park is to the maximum benefit of the people of the state to prevent a loss of function at the Death Valley National Park.

The proposed discharge is consistent with the state antidegradation policy.

18. Basis for Numerical Receiving Groundwater Limitations

The water quality objectives for groundwater with a "Municipal" beneficial use are defined in the Basin Plan and include both the primary and secondary drinking water standards (maximum contaminant levels, or MCLs), which are set by the Division of Drinking Water. For TDS there is a three-part standard: 500 mg/L Recommended, 1,000 mg/L Upper, and 1,500 mg/L Short-Term. Samples of the source water collected on October 17, 2023, detected TDS at a concentration of 580 mg/L, indicating that background water levels naturally exceed recommended MCL. Additionally, fluoride is naturally occurring in the source water at concentrations that exceed the MCL of 2.0 mg/L.

19. California Code of Regulations, Title 27

California Code of Regulations, title 27, Division 2, (Title 27) specifies regulatory and design criteria for discharges of solid wastes to land for treatment, storage, or disposal. CCR, title 27, sections 20090(b) state that discharges are exempt from title 27 requirements for waste disposal provided the activity meets and continues to meet the following pre-conditions:

*"(b) Wastewater - Discharges of wastewater to land, including but not limited to evaporation ponds, percolation ponds, or subsurface leachfields if the following conditions are met:*

- (1) The applicable RWQCB has issued WDRs, reclamation requirements, or waived such issuance;*
- (2) The discharge is in compliance with the applicable water quality control plan;*

*and*

*(3) The wastewater does not need to be managed according to Chapter 11, Division 4.5, title 22 of this code as a hazardous waste."*

Discharges from the Facility satisfy this exemption because: 1) the discharge is regulated by WDRs, 2) the discharge requirements and expected effluent quality are consistent with applicable water quality objectives, and 3) the discharge consists of waste from material that was filtered from local raw spring water that do not need to be managed as a hazardous waste.

20. California Environmental Quality Act (CEQA)

The National Park Service (NPS) prepared a Finding of No Significant Impact (FONSI) for the Rehabilitation of Water and Wastewater Systems at Furnace Creek and Cow Creek. The FONSI follows the development of an Environmental Assessment for a project to rehabilitate water and wastewater systems in Furnace Creek and Cow Creek.

The Water Board finds that the proposed issuance of WDRs for the Discharge of RO concentrate from the Cow Creek Facility to be categorically exempt from CEQA under the following provisions:

1. Existing Facilities (CCR Title 14, Section 15301) – The project involves negligible or no expansion of existing use. The RO systems are already in place, and the discharge is consistent with current operations.
2. Minor Alterations to Land (CCR Title 14, Section 15304) – The discharge occurs within existing conveyance infrastructure and does not involve significant grading or land disturbance.

21. Water Code Section 13241 considerations

Pursuant to Water Code section 13241, the requirements of this Order take into consideration the following factors.

- a. Past, present, and probable future beneficial uses of water – The receiving waters are the groundwaters of the Death Valley Groundwater Basin. The requirements in this Board Order are to maintain the most sensitive beneficial use: Municipal and Domestic Supply (MUN). The best management practices and receiving water limitations in this Order are based on water quality objectives and will not adversely affect present or probable future beneficial uses of groundwater, including municipal and domestic supply, and freshwater recharge.
- b. Environmental characteristics of the hydrographic unit under consideration, including the quality of the water available thereto –Death Valley is a closed groundwater basin and will experience increases in salt loading from natural and anthropogenic sources over time. The discharge of RO concentrate is not intended to introduce waste from sources outside of Cow Creek. The RO concentrate is the result of treatment of drinking water sourced from Nevares Springs upgradient from

the Facility and will be reintroduced to the same region during discharge.

- c. Water quality conditions that could reasonably be achieved through the coordinated control of all factors which will affect water quality in the area – Compliance with the requirements of this Order will protect groundwater quality. The Water Board will use its existing authority and these WDRs to ensure protection of water from these discharges.
- d. Economic considerations – The most economically efficient option is onsite discharge. Discharger may incur costs to install and improve infrastructure for properly discharging in compliance with these requirements.
- e. The need for developing housing within the region – Continued operation and eventual expansion or modification of the treatment plant is needed to treat raw spring water for potable use for the Cow Creek area. The Cow Creek housing area will benefit directly from the use of potable water from the Facility.
- f. The need to develop and use recycled water – This Order does not establish requirements on the need to develop and use recycled water. Under this Order the Facility will discharge RO concentrate to two irrigation ditches from the Cow Creek RO Plant.

## 22. Human Right to Safe, Clean, Affordable, and Accessible Water

It is the policy of the state that every human being has the right to safe, clean, affordable, and accessible water adequate for human consumption, cooking, and sanitary purposes. This Order promotes that policy by requiring Dischargers to meet water quality objectives, designed to protect human health and ensure that water is safe for domestic use.

## 23. Technical and Monitoring Reports

CWC, section 13267, provides the Lahontan Water Board with the authority to require technical and monitoring reports. Such technical reports are required by this Order, and the Monitoring and Reporting Program (MRP) that is attached to and made part of this Order.

The reports required by this Order are necessary to ensure the Discharger takes actions to demonstrate compliance and ensure water quality is protected. As such, the burden, including costs, of this monitoring bears a reasonable relationship to the need for that information and the benefits to be obtained from that information.

The Executive Officer may authorize additions or changes to monitoring and reporting requirements pursuant to CWC, section 13267.

## 24. Right to Petition

Any person aggrieved by this action of the Water Board may petition the State Water Board to review the action in accordance with California Water Code, section 13320, and CCR, title 23, sections 2050 et. seq. The State Water Board must receive the

petition by 5:00 p.m., 30 days after the date of this Order, except that if the thirtieth day following the date of this Order falls on a Saturday, Sunday, or state holiday, the petition must be received by the State Water Board by 5:00 p.m. on the next business day. Copies of the law and regulations applicable to filing petitions may be found on the internet at [http://www.waterboards.ca.gov/public\\_notices/petitions/water\\_quality](http://www.waterboards.ca.gov/public_notices/petitions/water_quality), or will be provided in hard copy or electronic format upon request.

25. Public Notification

The Lahontan Water Board has notified the Discharger and interested agencies and persons of its intent to issue Waste Discharge Requirements for this Facility and has provided them with an opportunity to submit their written views and recommendations.

26. Consideration of Public Comments

The Lahontan Water Board, in a public meeting, heard and considered all comments pertaining to this matter.

**IT IS HEREBY ORDERED**, pursuant to Water Code sections 13263, and 13267, that the Discharger must comply with the following:

**I. FLOW**

- A. The average daily flow of discharge during a 24-hour period must not exceed 57,600 gallons.
- B. The discharge must consist of RO concentrate blended with source water at all times to dilute concentrations of COC except when the RO treatment plant is not operating and only bypass source water is discharged.

**II. RECEIVING WATER LIMITATIONS**

- A. The discharge must not cause the presence of the following substances or conditions in the groundwater of the Death Valley Groundwater Basin:
  - 1. Chemical constituents: Groundwater which is designated as MUN must not contain concentrations of chemical constituents in excess of the MCL or Secondary MCL (SMCL) based upon drinking water standards specified in the following provisions of CCR, title 22.
    - a. Table 64431-A of section 64431 (Inorganic Chemicals),
    - b. Table 64431-B of section 64431 (Fluoride),
    - c. Table 64444-A of section 64444 (Organic Chemicals),
    - d. Table 64449-A of section 64449 (SMCLs – Consumer Acceptance Limits),
    - e. Table 64449-B of Section 64449 (SMCLs – Consumer Acceptance Ranges), and
    - f. This incorporation-by-reference is prospective including future changes to the incorporated provisions as the changes take effect.

2. The discharge must not cause an exceedance of background concentrations found in groundwater for constituents listed in II.A.1 with background concentrations that exceed WQOs.
3. Waters designated as AGR must not contain concentrations of chemical constituents in amounts that adversely affect the water for beneficial uses (i.e. agricultural purposes).

### III. REQUIREMENTS

#### A. General

1. The Discharger must ensure that all site operating personnel are familiar with the contents of this Order. A copy of the Order, and technical reports required by the Order (not including previously submitted monitoring reports) must be kept on the Facility premises and be available to operating personnel and Water Board staff.
2. The Discharger must implement Best Management Practices (BMPs) in the collection, treatment, storage, discharge, or waste disposal system to prevent spills, pollution, or nuisance.

#### B. Groundwater Monitoring

1. The Discharger must install a groundwater monitoring network in accordance with section VII.A. The groundwater monitoring network must be designed to monitor the water quality at the top of the water table upgradient and downgradient of the Facility. A minimum of three groundwater monitoring wells (one upgradient and two downgradient) is required for the monitoring network.
2. The construction, repair/maintenance, abandonment, or destruction of groundwater monitoring wells must be in accordance with the standards under water wells and monitoring wells in the California Well Standards Bulletin 74-81 (December 1981) and Supplemental Bulletin 74-90 (June 1991), adopted by the California Department of Water Resources (DWR). This incorporation-by-reference is prospective, including future changes to the incorporated California Well Standards as the changes take effect. Should any county or local agency have more stringent standards than that adopted by DWR, then these local standards must supersede the well standards of DWR, and the Discharger must comply with the more stringent standards.

#### C. Soil Monitoring

1. Arsenic loading in soil from RO concentrate discharge to the irrigation ditches must be monitored. Arsenic concentrations in soils of the irrigation ditch system must be within risk-based screening levels for residential areas. The San Francisco Bay Regional Water Quality Control Board developed the 2025 Environmental Screening Level Summary Tables for arsenic and other constituents.  
([https://www.waterboards.ca.gov/sanfranciscobay/water\\_issues/programs/ESL/](https://www.waterboards.ca.gov/sanfranciscobay/water_issues/programs/ESL/))

ESL\_Summary\_Tables\_Rev3.pdf) The table establishes the residential direct contact screening level for arsenic in soil at 0.032 mg/kg. Soil samples must not exceed this screening level.

2. The Discharger must propose a Soil Management Plan to address the actions to be taken to prevent arsenic in soil from exceeding screening levels listed in III.C.1. The Soil Management Plan must be accepted by Water Board staff prior to implementation.

#### **IV. PROHIBITIONS**

- A. Creation of pollution is prohibited.
- B. The discharge of waste classified as hazardous (CCR, title 22, section 66261) is prohibited.
- C. The discharge of waste to surface waters is prohibited.
- D. The discharge of waste except to the authorized discharge locations identified in Finding No. 8 in this Board Order is prohibited.
- E. The discharge, bypass, or diversion of RO concentrate from the Facility, except as authorized by this Order, or to adjacent land areas is prohibited.
- F. The Facility's discharge of RO concentrate to a location other than the authorized location described in this Order is prohibited.
- G. Failure to maintain and operate the Facility in compliance with this Order is prohibited.
- H. Failure to immediately notify the Regional Water Board of any planned changes that would alter the method of treatment or the discharge is prohibited.

#### **V. PROVISIONS**

##### **A. Licensed Professionals**

1. A California licensed professional geologist must prepare groundwater monitoring well installation work plans and certify as-built well completion reports.
2. A California licensed surveyor must survey groundwater monitoring wells (e.g., northing and easting, ground surface elevation, top of casing elevation, top of monument elevation, and well measuring point), which is to be included in any as-built well completion reports.

##### **B. Standard Provisions**

The Discharger must comply with the "Standard Provisions for Waste Discharge Requirements," in Attachment E which is made part of this Order.

C. Monitoring and Reporting

Pursuant to CWC, section 13267, subdivision (b), the Discharger must comply with the monitoring and reporting requirements as established in the attached MRP No. R6-2026-0010 and as specified by the Executive Officer. The MRP may be modified by the Water Board Executive Officer.

D. Electronic Submittal of Information

All technical reports, laboratory analytical results (including but not limited to soil and water data), groundwater monitoring well survey data, site maps, groundwater monitoring well construction logs, boring logs, and depth to groundwater must be uploaded electronically over the internet to the State Water Board's GeoTracker website. This requirement is in addition to, and not superseded by, any other applicable reporting requirement.

E. Site Protections

The Facility must be adequately protected against overflow, washout, inundation, structural damage or a significant reduction in efficiency resulting from a storm or flood having a recurrence interval of once in 100 years

**VI. REPORTING FACILITY CHANGES**

A. Material Changes

Pursuant to CWC, section 13260(c), any proposed material changes in the character of the waste, manner or method of treatment or disposal, increase of discharge, or location of discharge, requires submittal of an updated Report of Waste Discharge. The Discharger must submit the updated ROWD to the Water Board at least 120 days prior to making any material change. Material changes include, but are not limited to, any of the following:

1. Increase in area or location used for waste discharge beyond that described in this Order.
2. Significant change in storage or application method, location, or volume of waste discharged (e.g., change from the use of irrigation ditches to a different system).
3. Change in source water treated at the Facility (e.g., water from a source other than Nevares Springs being used for RO treatment).
4. Closure of the Facility on either a temporary or permanent basis must be submitted to the Water Board at least 30 days in advance.

**VII. REQUIRED PLANS AND REPORTS**

A. Groundwater Monitoring Well Network

Pursuant to the CWC, section 13267, the Discharger must submit the following:

1. **No later than 90 days** following the adoption of this Order, the Discharger must submit for Water Board staff review and concurrence a work plan for the installation of groundwater monitoring wells, establishing a groundwater monitoring network consisting of at least three (3) groundwater monitoring wells (one upgradient and two downgradient) to adequately monitor water quality upgradient and downgradient of the Facility. Prior to constructing the well network, a work plan must be submitted to include:
  - a. Proposed new well location(s) on a Facility site map.
  - b. Proposed well design: casing diameter and material; screen interval, slot size, and depth of well; drilling method; well development and purging methods; and waste handling and disposal.
  - c. A list of initial water quality analyses that includes the constituents of concern in MRP No. R6-2026-0010, Attachment A.
2. **No later than 12 months** after work plan approval, the Discharger must implement the approved work plan and submit to the Water Board notification of well installation completion.
3. **No later than 90 days** following well installation, the Discharger must submit to the Water Board (upload to GeoTracker) an As-Built Well Completion Report. The report must include, at minimum, the drillers log, field data sheets, water quality analytical data and laboratory report, a Facility site map showing all well locations, and survey data (coordinate location in decimal degrees, top of casing elevation in feet above mean sea level [amsl], and ground surface elevations in feet amsl).

B. Sample and Analysis Plan

**No later than 90 days** following adoption of this Order, the Discharger must submit a revised Sampling and Analysis Plan (SAP) for Water Board staff review and concurrence, including procedures for sampling of and analysis for effluent and groundwater monitoring wells. Periodic updates to the SAP may be necessary to reflect changes in the monitoring network (i.e. new groundwater monitoring wells installed), sampling procedures, or analytical methods and must be submitted for Water Board staff review and concurrence prior to implementation.

I, Ben Letton, Executive Officer, do hereby certify that the foregoing is a full, true, and correct copy of an Order adopted by the California Regional Water Quality Control Board, Lahontan Region, on May 6, 2026.

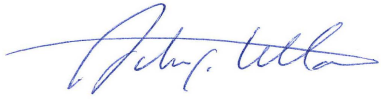

---

BEN LETTON  
EXECUTIVE OFFICER

- Attachments:
- A. Cow Creek Area – General Location Map
  - B. Cow Creek RO Plant – Site Map
  - C. Cow Creek – Discharge Area and Groundwater Monitoring Wells
  - D. Cow Creek RO Plant – Process Flow Diagram
  - E. Standard Provisions for Waste Discharge Requirements

ATTACHMENT A – GENERAL LOCATION MAP

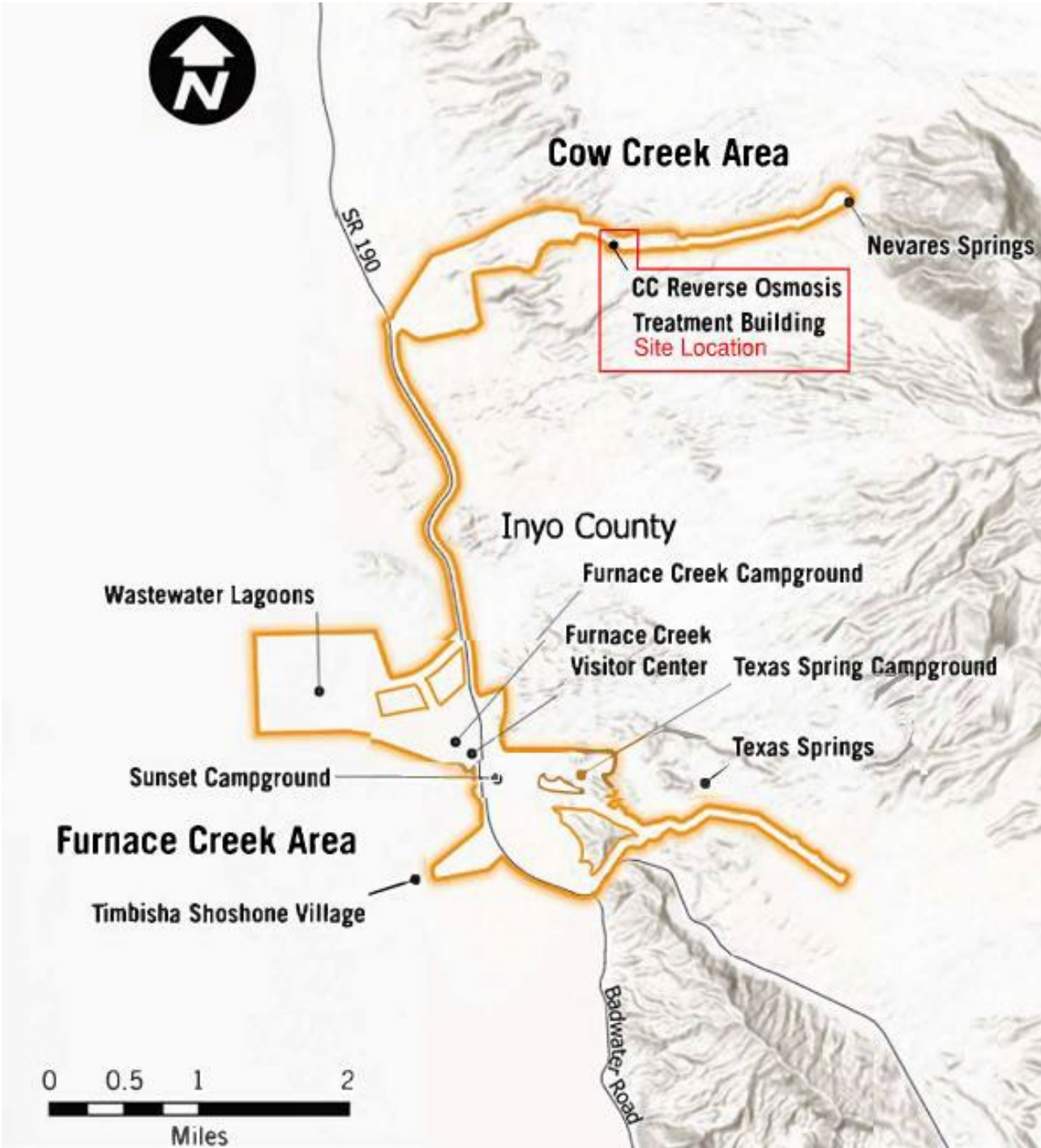

# ATTACHMENT B – COW CREEK RO PLANT SITE MAP

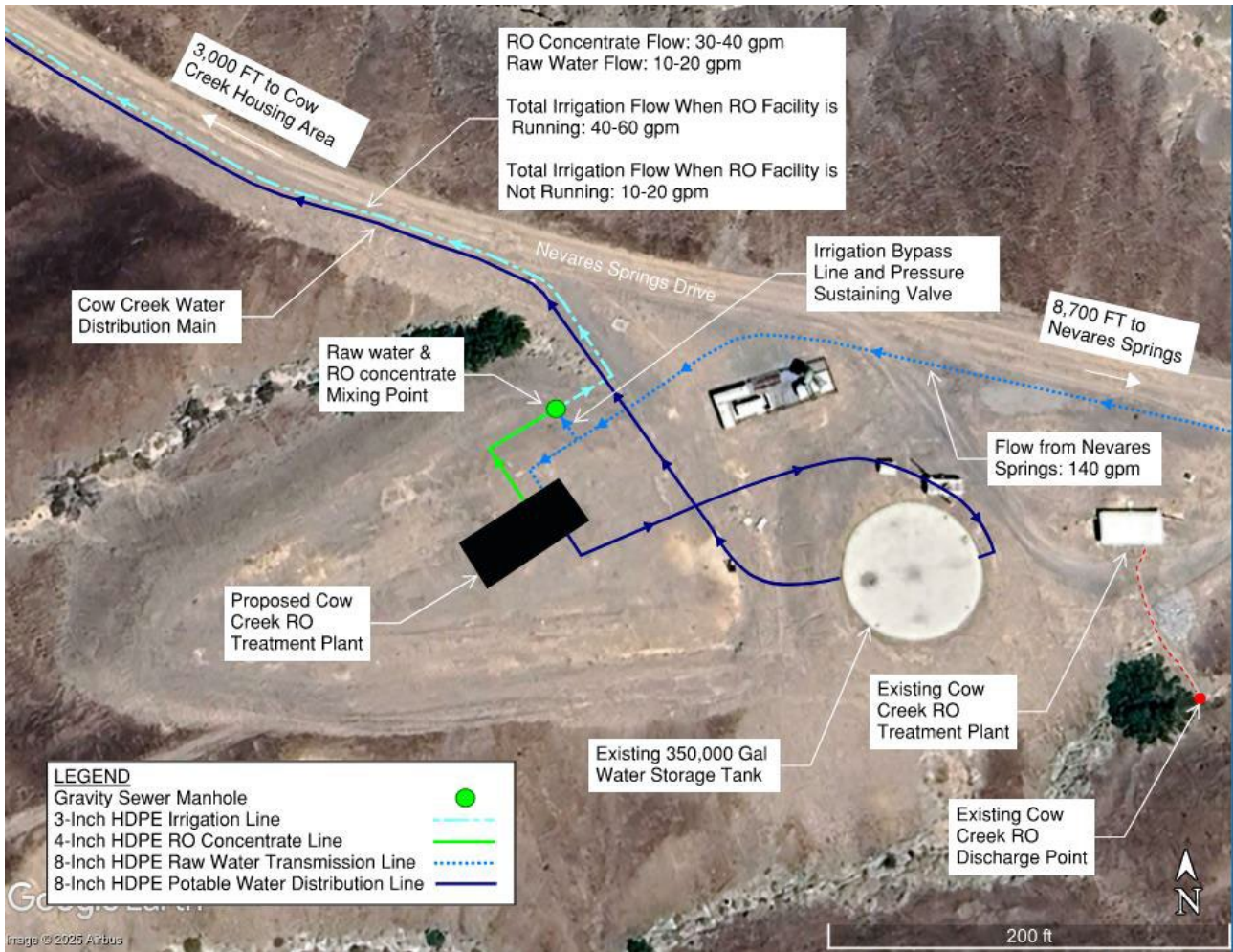

# ATTACHMENT C – COW CREEK DISCHARGE AREA AND PROPOSED GROUNDWATER MONITORING WELL NETWORK

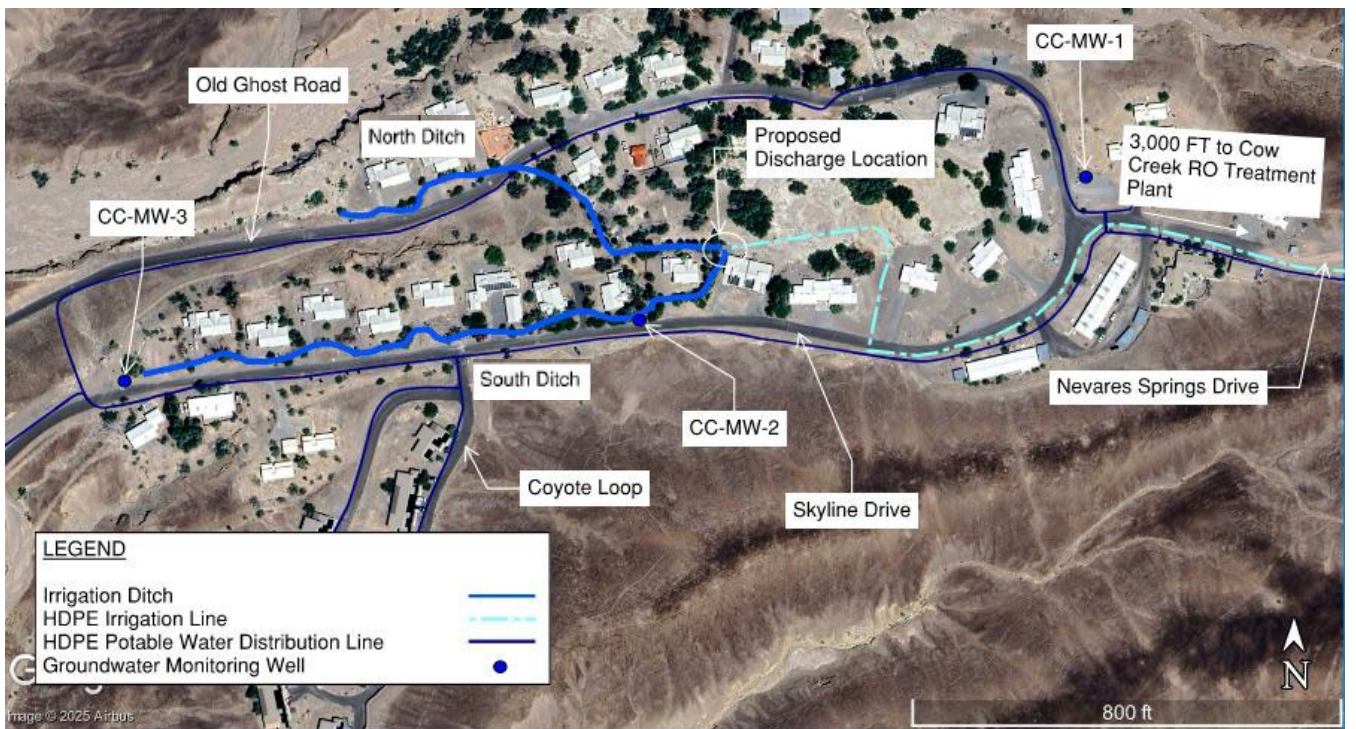
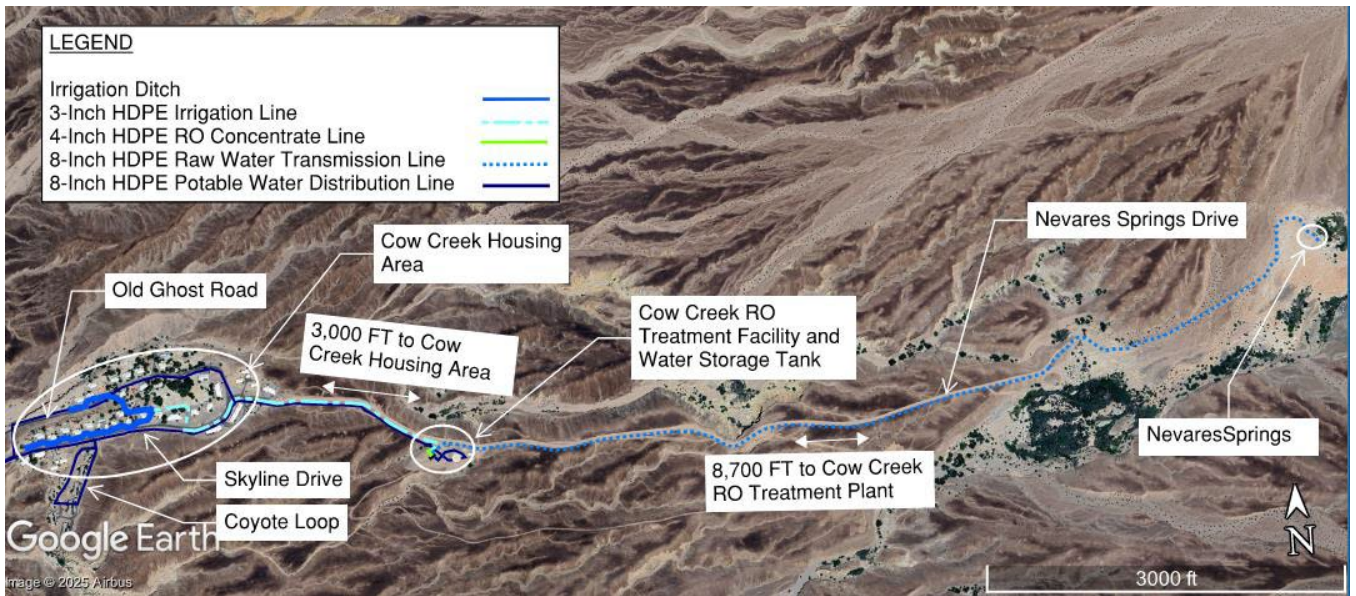

# ATTACHMENT D – COW CREEK RO PLANT – PROCESS FLOW DIAGRAM

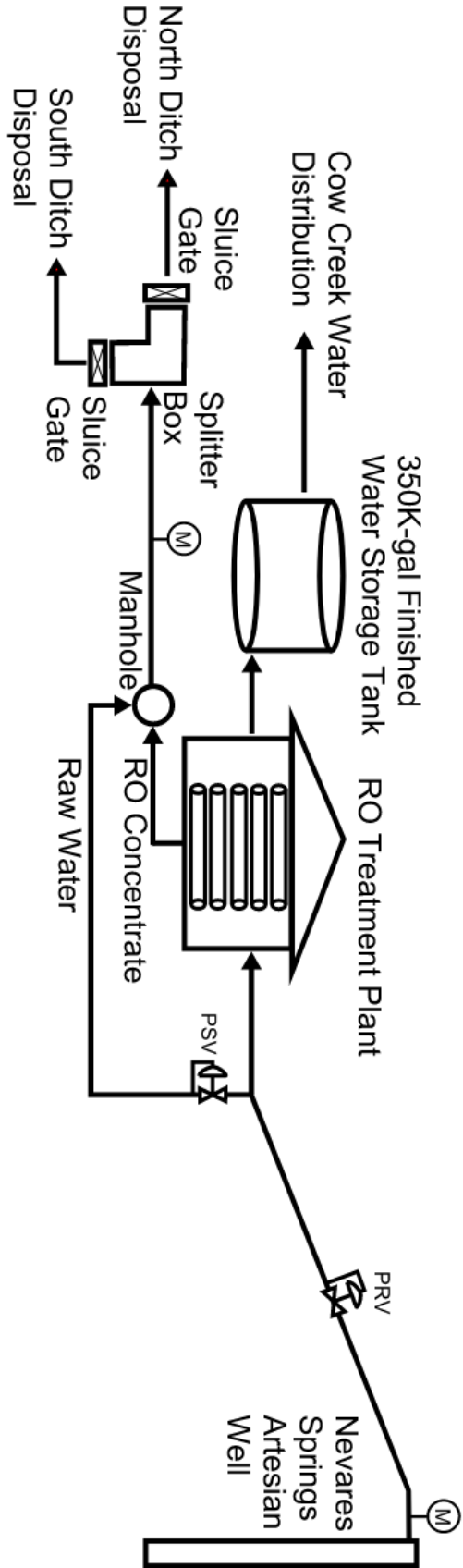

## ATTACHMENT E

### STANDARD PROVISIONS FOR WASTE DISCHARGE REQUIREMENTS

#### 1. Inspection and Entry

The Discharger must allow Lahontan Water Board staff, upon presentation of credentials, to:

- a. Enter upon premises at reasonable times where an effluent source is located or in which any required records are kept;
- b. Access and copy at reasonable times any records relating to the discharge or relating to compliance with the waste discharge requirements;
- c. Inspect monitoring and control equipment, practices, or operations regulated or required under this Order at reasonable times; and
- d. Sample or monitor at reasonable times, for the purpose of assuring compliance with this Order or as otherwise authorized by the Water Code, any substances or parameters at this location.

#### 2. Reporting Requirements

- a. Pursuant to California Water Code 13267(b), the Discharger must report any noncompliance that may endanger human health or the environment. The Discharger must immediately notify the Lahontan Water Board after becoming aware of when an adverse condition occurred as a result of this discharge; a written report shall be provided within ten days of the time the Discharger becomes aware of the incident. The written report shall contain a description of the noncompliance and its cause, the period of noncompliance, the anticipated time to achieve full compliance, and the steps taken or planned to reduce, eliminate, and prevent recurrence of the noncompliance. A final certified report must be submitted through the online GeoTracker system. An adverse condition includes, but is not limited to, spills of petroleum products or toxic chemicals, sanitary sewer overflows, or damage to control facilities that could affect compliance.
- b. Pursuant to California Water Code Section 13260 (c), any proposed material changes in the character of the waste, manner or method of treatment or disposal, increase of discharge, or location of discharge, shall be reported to the Lahontan Water Board at least 120 days in advance of implementation of any such proposal. This shall include, but not be limited to, all significant soil disturbances.

- c. The owner(s) of, and Discharger upon, property subject to waste discharge requirements shall be considered to have a continuing responsibility for ensuring compliance with applicable waste discharge requirements in the operations or use of the owned property. Pursuant to California Water Code Section 13260(c), any change in the ownership and/or operation of property subject to the waste discharge requirements shall be reported to the Lahontan Water Board. Notification of applicable waste discharge requirements shall be furnished in writing to the new owners and/or operators, and a copy of such notification shall be sent to the Lahontan Water Board.
- d. If a Discharger becomes aware that any information submitted to the Lahontan Water Board is incorrect, the Discharger shall immediately notify the Lahontan Water Board, in writing, and correct that information.
- e. Reports required by the waste discharge requirements, and other information requested by the Lahontan Water Board, must be signed by a duly authorized representative of the Discharger. Under Section 13268 of the California Water Code, any person failing or refusing to furnish technical or monitoring reports, or falsifying any information provided therein, is guilty of a misdemeanor and may be liable civilly in an amount of up to one thousand dollars (\$1000) for each day of violation.
- f. If the Discharger becomes aware that their waste discharge requirements are no longer needed (because the project will not be built or the discharge will cease) the Discharger shall notify the Lahontan Water Board in writing and request that their waste discharge requirements be rescinded.

3. Right to Revise Waste Discharge Requirements

The Lahontan Water Board reserves the privilege of changing all or any portion of the waste discharge requirements upon legal notice to and after opportunity to be heard is given to all concerned parties.

4. Duty to Comply

Failure to comply with the waste discharge requirements may constitute a violation of the California Water Code and is grounds for enforcement action or for permit termination, revocation and reissuance, or modification.

5. Duty to Mitigate

The Discharger shall take all reasonable steps to minimize or prevent any discharge in violation of the waste discharge requirements which has a reasonable likelihood of adversely affecting human health or the environment.

6. Proper Operation and Maintenance

The Discharger shall at all times properly operate and maintain all facilities and systems of treatment and control (and related appurtenances) that are installed or used by the Discharger to achieve compliance with the waste discharge requirements. Proper operation and maintenance includes adequate laboratory control, where appropriate, and appropriate quality assurance procedures. This provision requires the operation of backup or auxiliary facilities or similar systems that are installed by the Discharger, when necessary to achieve compliance with the conditions of the waste discharge requirements.

7. Waste Discharge Requirement Actions

The waste discharge requirements may be modified, revoked and reissued, or terminated for cause. The filing of a request by the Discharger for waste discharge requirement modification, revocation and reissuance, termination, or a notification of planned changes or anticipated noncompliance, does not stay any of the waste discharge requirements conditions.

8. Property Rights

The waste discharge requirements do not convey any property rights of any sort, or any exclusive privileges, nor does it authorize any injury to private property or any invasion of personal rights, nor any infringement of federal, state or local laws or regulations.

9. Enforcement

The California Water Code provides for civil liability and criminal penalties for violations or threatened violations of the waste discharge requirements including imposition of civil liability or referral to the Attorney General.

10. Availability

A copy of the waste discharge requirements, monitoring and reporting requirements, and sampling and analysis plan shall be kept and maintained by the Discharger and always be available to operating personnel.

11. Severability

Provisions of the waste discharge requirements are severable. If any provision of the requirements is found invalid, the remainder of the requirements shall not be affected.

**CALIFORNIA REGIONAL WATER QUALITY CONTROL BOARD  
LAHONTAN REGION**

**MONITORING AND REPORTING PROGRAM  
R6-2026-0010  
WDID NO. 6B142509005**

**FOR**

**DEATH VALLEY NATIONAL PARK  
COW CREEK REVERSE OSMOSIS WATER TREATMENT FACILITY**

Inyo County

---

This Monitoring and Reporting Program (MRP) No. R6-2026-0010 is issued to Death Valley National Park (Discharger) for the Cow Creek Reverse Osmosis Water Treatment Plant (Facility) pursuant to California Water Code (CWC), section 13267 and incorporates requirements for influent, effluent, and groundwater monitoring and reporting; and Facility monitoring, maintenance, and reporting. The technical reports required by Board Order No. R6-2026-0010 and MRP No. R6-2026-0010 are necessary to assure compliance with the Waste Discharge Requirements (WDRs). The burden, including costs, of these reports, bears a reasonable relationship to the need for the report and the benefits to be obtained from the reports.

**I. MONITORING**

The Discharger must comply with the monitoring requirements outlined below. All monitoring and inspecting activities must be documented, and all sampling must be conducted in accordance with an approved Sampling and Analysis Plan (SAP) that includes quality assurance and quality control standards and procedures, as described in the General Provisions for Monitoring and Reporting (Attachment B of this MRP).

All samples collected in accordance with this MRP, except for field parameters, are to be analyzed by a California state-certified laboratory using United States Environmental Protection Agency (USEPA) analytical methods or the most recently approved SW-846 USEPA method or other equivalent USEPA method. An alternate method may be used if acceptable to the Executive Officer.

**A. Influent**

The Discharger must collect samples of the influent source water to be analyzed for the COCs in accordance with the frequencies listed in Attachment A of this MRP. Samples are to be collected from Nevares Springs prior to treatment by the Facility.

**B. Effluent**

The Discharger must monitor the effluent to ensure compliance with Board Order No. R6-2026-0010. The Discharger must collect the following data and record it in a permanent logbook kept on site.

1. Volumes

Total volume of flow, in million gallons (MG), of RO concentrate from the Facility prior to blending with source water for each day and month as measured by the RO concentrate flow meter.

Total volume of flow, in MG, of discharge of RO concentrate after blending with source water for each day and month before entry to the ditch irrigation system.

2. Average Daily Flow Rates

Calculated average daily flow rate, in million gallons per day (MGD), of RO concentrate from the Facility prior to blending with source water for each month.

Calculated average daily flow rate, in MGD, of discharge of RO concentrate after blending with source water for each month to the ditch irrigation system.

3. Constituents of Concern (COCs)

Samples must be analyzed for the COCs in accordance with the frequencies listed in Attachment A of this MRP. Samples are to be collected at the following locations: (1) the inlet to the pipe prior to blending, (2) the discharge outfall to the irrigation ditch system after blending, and (3) the last point where liquid samples can be collected in both the north and south ditch.

4. Inspections

Monthly visual inspections of the Facility's discharge equipment must be performed to identify areas needing maintenance or repair. These inspections should include routine infrastructure evaluations to address material degradation. If there is nothing noteworthy for a given month, that must be noted.

C. Groundwater

The groundwater monitoring program monitors the quality of groundwater upgradient and downgradient of the Facility through the collection of groundwater samples for laboratory analysis and field measurements of water quality parameters.

1. Monitoring Points

Board Order No. R6-2026-0010 requires the Discharger to install groundwater monitoring wells in the Cow Creek area, establishing a groundwater monitoring network to adequately monitor upgradient and downgradient of the irrigation ditch system.

2. Depth to Groundwater

Prior to purging and sampling, the Discharger must measure and record the depth below the ground surface of the static groundwater elevation (feet below ground surface [bgs]) in all groundwater monitoring wells. The measurements must be accurate to the nearest 0.01 foot.

3. Groundwater Purging and Sampling

Prior to sampling, all groundwater monitoring wells must be purged using either standard or low-flow techniques until dissolved oxygen (DO), electrical conductivity, pH, temperature, and turbidity of extracted well water have stabilized. These parameters will be considered stable when three consecutive readings have pH values within +/- 0.1 pH units, temperature values within +/- two (2) degrees Celsius, and electrical conductivity values within +/- three (3) percent.

4. Constituents of Concern and Field Parameters

The Discharger must monitor, at each groundwater monitoring well, all COCs and field parameters in accordance with the frequencies listed in Attachment A of this MRP.

5. Calibration Documentation

The Discharger must document instrument calibration and performance checks to verify proper operation of the field monitoring equipment.

6. Locational Data

Permanent groundwater sampling locations must be surveyed by a California registered surveyor. The surveyed locational information for these sampling points must be submitted using the Geo\_XY file to the GeoTracker database.

D. Soil

The soil monitoring program monitors the quality of soil within the irrigation ditches through the collection of soil samples for laboratory analysis.

1. Monitoring Points and Constituents of Concern

The Discharger must collect grab soil samples at the outlet pipe where the discharge enters the irrigation ditch system and the midpoints of the north and south ditches for a total of three soil samples. The soil samples must be analyzed for all COCs in accordance with the frequencies listed in Attachment A of this MRP.

## 2. Soil Management Work Plan

Soil concentrations must be compared with the screening level (0.032 mg/kg) outlined in the [https://www.waterboards.ca.gov/sanfranciscobay/water\\_issues/programs/ESL/ESL\\_Summary\\_Tables\\_Rev3.pdf](https://www.waterboards.ca.gov/sanfranciscobay/water_issues/programs/ESL/ESL_Summary_Tables_Rev3.pdf) developed by the San Francisco Bay Regional Water Board. A work plan for soil removal must be developed for Regional Water Board staff acceptance when arsenic concentrations in soil reach or exceed the screening level of 0.032 mg/kg. Procedures contained in the Soil Management Work Plan must be followed to address arsenic concentrations in soil. Soil samples must be collected after soil removal.

## II. DATA ANALYSIS

- A. Time series plots must be prepared for all constituents sampled in groundwater to determine whether concentrations are increasing, decreasing, or staying the same for each monitoring well. Time series plots must show all data collected for each constituent in each groundwater monitoring well.
- B. The Discharger must compare concentrations for all constituents sampled in downgradient groundwater monitoring wells to constituent concentrations in the background groundwater monitoring well and prepare a narrative of that comparison.
- C. For those constituents sampled that have a receiving water limit established in Board Order No. R6-2026-0010, Section II, the Discharger must compare the constituent concentration in each groundwater monitoring well for the reporting period to the receiving water limit value and prepare a narrative analysis of that comparison.

## III. REPORTING REQUIREMENTS

The Discharger must comply with the following reporting requirements.

### A. Submittal of Electronic Laboratory Data

All laboratory data collected during the corresponding reporting period (Table 1), must be submitted electronically to the Water Board by uploading to the State Water Board's GeoTracker system under Global Identification number WDR100057301, per the following schedule. The laboratory data must be uploaded in Electronic Data Format (EDF).

**Table 1. Laboratory Reporting Schedule**

<b>Sampling and Reporting Period</b>	<b>EDF Upload Due Date</b>
January 1 – March 31	May 1
April 1 – June 30	August 1
July 1 – September 30	November 1
October 1 – December 31	February 1

**B. Scheduled Reports to be Filed with the Water Board**

The following periodic reports (Table 2) must be submitted electronically to the Water Board by uploading to the State Water Board's GeoTracker system under Global Identification number WDR100057301, per the following schedule.

**Table 2. Monitoring and Reporting Schedule**

<b>Report Name</b>	<b>Sampling and Reporting Period</b>	<b>Report Due Date</b>
First Quarter Monitoring Report	January 1 – March 31	May 1
Second Quarter Monitoring Report	April 1 – June 30	August 1
Third Quarter Monitoring Report	July 1 – September 30	November 1
Fourth Quarter Monitoring Report	October 1 – December 31	February 1
Annual Report	January 1 – December 31	March 1

The Discharger must use the example form provided in Attachment C of this MRP, or other form with the same information, as a cover letter for all reports submitted to the Water Board associated with this MRP.

**1. Quarterly Monitoring Reports**

Each quarterly self-monitoring report must include the following information.

- a. All laboratory and field data collected during the reporting period in accordance with the approved SAP, as outlined in MRP, Section I.
- b. All visual observations made during the reporting period, as outlined in MRP, Section I.
- c. Tabulated results of all sampling and laboratory analyses collected in compliance with MRP, Section I.
- d. All data analyses performed during the reporting period, as outlined in MRP, Section II.
- e. A written explanation for all violations identified during the reporting period, including dates and cause of violations and measures to prevent violation recurrence. Include a specific assessment as to whether any data indicate a violation of receiving water quality objective as a result of the discharge.
- f. Calculate and illustrate on a site plan and/or aerial photograph, the following aquifer characteristics: the depth to groundwater (feet bgs) in each groundwater monitoring well; the static water level (feet above mean sea level) in each groundwater monitoring well; the direction of the groundwater gradient beneath and around the Facility (degrees from true north); and the current groundwater surface elevation contours for the reporting period.

- g. Any operational problems and maintenance activities affecting Facility performance, RO concentrate discharges, and irrigation ditch system, including any corrective actions taken and/or a schedule for completion of corrective actions, if needed.
- h. Copies of all field and well sampling data sheets for the reporting period.
- i. Copies of all laboratory analytical reports for the reporting period.
- j. Where additional data are collected above minimum monitoring requirements, that additional data must be reported.

## 2. Annual Monitoring Reports

Each annual self-monitoring report must include, but not be limited to, the following information.

- a. Tabulated results of all sampling and laboratory analyses collected in compliance with MRP, Section I, for the last five years at minimum and current reporting period data.
- b. A scaled Facility site map showing Facility components, discharge location(s), and monitoring well locations, and the most current groundwater surface elevation contours.
- c. Calibration methods and any discrepancies of any meters used for field parameter evaluations after calibration is performed.
- d. A brief chronological summary of dates of any operational problems and maintenance activities that may impact water quality at the site.
- e. Names and grades of all certified operators.

## C. Unscheduled Reports to be Filed with the Water Board

The following reports must be submitted to the Water Board as specified below.

### 1. Spill and Incident Reporting

- a. Within 24 hours of becoming aware of any spill or incident that results in noncompliance with the Board Order, the Discharger must report the occurrence of noncompliance to the Water Board's Victorville office by calling the general telephone number listed below. The report must include the time, date, place, and nature of noncompliance, and the name and number of the reporting person. If prompted to leave a voicemail, the message must include the same reporting information listed above. Spills of hazardous substances must be reported to the California Office of Emergency Services (Cal OES) at 1-800-852-7550 and Victorville Office (760) 241-6583.

- b. Within two weeks of becoming aware of any spill or incident that results in noncompliance with the Board Order, the Discharger must submit a written incident report to the Water Board. The report must contain a description of the noncompliance, its causes, duration, associated volumes of discharges, and the actual or anticipated time for achieving compliance. The report must include complete details of the steps that the Discharger has taken or intends to take, to prevent recurrence.

## 2. Significant Earthquake Event

After a significant<sup>1</sup> or greater earthquake event at or near the Facility, the Discharger must notify the Water Board within 72 hours of any physical damage to infrastructure, treatment components, containment features, or groundwater monitoring systems. All repairs must be documented in the Annual Report required under MRP Section III.B.2.

## 3. Extreme Weather Event

After an extreme weather event<sup>2</sup> at or near the Facility, the Discharger must notify the Water Board within 72 hours of any physical damages to infrastructure, waste collection components, containment features, or groundwater monitoring systems. All repairs must be documented in the Annual Report required under MRP Section III.B.2.

## D. Sample and Analysis Plan

**No later than 90 days** following adoption of the Order, the Discharger must submit a revised Sampling and Analysis Plan (SAP) for Water Board staff review and concurrence, including procedures for sampling of and analysis for effluent and groundwater monitoring wells. Periodic updates to the SAP may be necessary to reflect changes in the monitoring network (i.e. new groundwater monitoring wells installed), sampling procedures, or analytical methods and must be submitted for Water Board staff review and concurrence prior to implementation.

## E. Monitoring Well Logs

All groundwater monitoring wells and all other borings installed to satisfy the requirements of this MRP must be drilled by a licensed drilling contractor and must

---

<sup>1</sup> 1 A significant earthquake is a seismic event classified according to the United States Geological Survey (USGS) Earthquake Hazard Program as a moderate earthquake measuring between 5 and 5.9 on the Richter scale, or higher. The Discharger may use the Modified Mercalli Intensity Scale VI or higher for equivalent ground shaking generated by a significant earthquake of Richter magnitude 5.0 or higher as contained with the USGS Earthquake Hazard Program Magnitude/Intensity Comparison chart found at <https://earthquake.usgs.gov>

<sup>2</sup> An extreme weather event refers to a weather phenomenon with enough intensity to cause physical damage to the Facility or any of its infrastructure or disruption in wastewater conveyance or treatment systems. Extreme weather refers to unusual, severe, or unseasonal weather conditions, and can include extreme heat, excessive or unusual precipitation and flooding, wildfires, severe wind, and extended droughts.

be logged during drilling under the direct supervision of either a California licensed Professional Geologist or Professional Civil Engineer with expertise in stratigraphic well logging. Such logs must be submitted to the Water Board within 90 days following completion of fieldwork and uploaded to the State Water Board's GeoTracker system under Global Identification number WDR100027966.

F. Monitoring Well Repairs

When groundwater monitoring wells are repaired, replaced, destroyed, or installed, a work plan must be prepared under the direct supervision of either a California licensed Professional Geologist or Professional Civil Engineer with competence in groundwater hydrogeology and submitted to Water Board staff for review and acceptance prior to the beginning of any work.

G. General Provisions

The Discharger must comply with Attachment B, "General Provisions for Monitoring and Reporting," which is attached to and made part of this MRP.

H. Failure to Furnish Reports

Any person failing or refusing to furnish technical or monitoring reports or falsifying any information provided therein is guilty of a misdemeanor and may be liable civilly in an amount of up to one thousand dollars (\$1,000) for each day of violation pursuant to CWC, section 13268.

I. Electronic Reporting Requirements

The Discharger must submit reports, including soil and water data, electronically over the internet to the State Water Resources Control Board's GeoTracker system. This requirement is in addition to, and not superseded by, any other applicable reporting requirement. The Discharger must provide the monitoring report to the Water Board, as specified in this MRP, and upload the full monitoring report into GeoTracker, as stipulated by CCR, title 23.

For all other types of documents and correspondence, please send it to the Water Board's email address at [Lahontan@waterboards.ca.gov](mailto:Lahontan@waterboards.ca.gov) and include the WDID No. and Facility name in the subject line.

Ordered by:   
BEN LETTON  
EXECUTIVE OFFICER

Dated: May 6, 2026

Attachments: A. Monitoring Program  
B. General Provisions for Monitoring and Reporting  
C. Example Cover Form for Self-Monitoring Reports

## ATTACHMENT A – MONITORING PROGRAM

RO Concentrate and Source Water				
Constituents of Concern	Units	Sample Type	Sample Frequency	Reporting Frequency
Electrical conductivity	micro siemens per centimeter ( $\mu\text{S}/\text{cm}$ )	Grab	Weekly	Quarterly
pH	pH units	Grab	Weekly	Quarterly
Total dissolved solids	mg/L	Grab	Monthly	Quarterly
Arsenic	mg/L	Grab	Monthly	Quarterly
Fluoride	mg/L	Grab	Monthly	Quarterly
Calcium	mg/L	Grab	Annually	Annually
Magnesium	mg/L	Grab	Annually	Annually
Potassium	mg/L	Grab	Annually	Annually
Sodium	mg/L	Grab	Annually	Annually
Bicarbonate	mg/L	Grab	Annually	Annually
Carbonate	mg/L	Grab	Annually	Annually
Chloride	mg/L	Grab	Annually	Annually
Nitrate as nitrogen	mg/L	Grab	Annually	Annually
Sulfate	mg/L	Grab	Annually	Annually
Anion sum	milliequivalents per Liter (meq/L)	Grab	Annually	Annually
Cation sum	meq/L	Grab	Annually	Annually
Total alkalinity	mg/L	Grab	Annually	Annually
Total Hardness	mg/L	Grab	Annually	Annually
Aluminum	micrograms per Liter ( $\mu\text{g}/\text{L}$ )	Grab	Annually	Annually
Barium	$\mu\text{g}/\text{L}$	Grab	Annually	Annually
Cadmium	$\mu\text{g}/\text{L}$	Grab	Annually	Annually
Total chromium	$\mu\text{g}/\text{L}$	Grab	Annually	Annually
Cobalt	$\mu\text{g}/\text{L}$	Grab	Annually	Annually
Copper	$\mu\text{g}/\text{L}$	Grab	Annually	Annually
Iron	$\mu\text{g}/\text{L}$	Grab	Annually	Annually
Lead	$\mu\text{g}/\text{L}$	Grab	Annually	Annually
Mercury	$\mu\text{g}/\text{L}$	Grab	Annually	Annually
Molybdenum	$\mu\text{g}/\text{L}$	Grab	Annually	Annually
Nickel	$\mu\text{g}/\text{L}$	Grab	Annually	Annually
Selenium	$\mu\text{g}/\text{L}$	Grab	Annually	Annually
Silver	$\mu\text{g}/\text{L}$	Grab	Annually	Annually
Thallium	$\mu\text{g}/\text{L}$	Grab	Annually	Annually
Vanadium	$\mu\text{g}/\text{L}$	Grab	Annually	Annually
Zinc	$\mu\text{g}/\text{L}$	Grab	Annually	Annually

Groundwater				
Constituent/Parameter	Units	Sample Type	Sample Frequency	Reporting Frequency
<b>Field Parameters</b>				
Color	visual	field	Quarterly	Quarterly
Electrical conductivity	µS/cm	field	Quarterly	Quarterly
pH	pH units	field	Quarterly	Quarterly
Depth to Groundwater	feet below ground surface	field	Quarterly	Quarterly
Temperature	degrees Celsius	field	Quarterly	Quarterly
<b>Constituents of Concern</b>				
Total dissolved solids	mg/L	Grab	Quarterly	Quarterly
Arsenic	mg/L	Grab	Quarterly	Quarterly
Fluoride	mg/L	Grab	Quarterly	Quarterly
Calcium	mg/L	Grab	Annually	Annually
Magnesium	mg/L	Grab	Annually	Annually
Potassium	mg/L	Grab	Annually	Annually
Sodium	mg/L	Grab	Annually	Annually
Bicarbonate	mg/L	Grab	Annually	Annually
Carbonate	mg/L	Grab	Annually	Annually
Chloride	mg/L	Grab	Annually	Annually
Nitrate as nitrogen	mg/L	Grab	Annually	Annually
Sulfate	mg/L	Grab	Annually	Annually
Anion sum	meq/L	Grab	Annually	Annually
Cation sum	meq/L	Grab	Annually	Annually
Total alkalinity	mg/L	Grab	Annually	Annually
Total Hardness	mg/L	Grab	Annually	Annually
Aluminum	µg/L	Grab	Annually	Annually
Barium	µg/L	Grab	Annually	Annually
Cadmium	µg/L	Grab	Annually	Annually
Total chromium	µg/L	Grab	Annually	Annually
Cobalt	µg/L	Grab	Annually	Annually
Copper	µg/L	Grab	Annually	Annually
Iron	µg/L	Grab	Annually	Annually
Lead	µg/L	Grab	Annually	Annually
Mercury	µg/L	Grab	Annually	Annually
Molybdenum	µg/L	Grab	Annually	Annually
Nickel	µg/L	Grab	Annually	Annually
Selenium	µg/L	Grab	Annually	Annually
Silver	µg/L	Grab	Annually	Annually
Thallium	µg/L	Grab	Annually	Annually
Vanadium	µg/L	Grab	Annually	Annually
Zinc	µg/L	Grab	Annually	Annually

<b>Soil</b>				
<b>Constituent of Concern</b>	<b>Units</b>	<b>Sample Type</b>	<b>Sample Frequency</b>	<b>Reporting Frequency</b>
Arsenic	Milligrams per kilogram (mg/kg)	Grab	Annual	Annual

## ATTACHMENT B

### CALIFORNIA REGIONAL WATER QUALITY CONTROL BOARD LAHONTAN REGION

#### **GENERAL PROVISIONS** FOR MONITORING AND REPORTING

##### 1. **SAMPLING AND ANALYSIS**

- a. All analyses shall be performed in accordance with the current edition(s) of the following documents:
  - i. Standard Methods for the Examination of Water and Wastewater
  - ii. Methods for Chemical Analysis of Water and Wastes, EPA
- b. All analyses shall be performed in a laboratory certified to perform such analyses by the California State Department of Health Services or a laboratory approved by the Regional Board Executive Officer. Specific methods of analysis must be identified on each laboratory report.
- c. Any modifications to the above methods to eliminate known interferences shall be reported with the sample results. The methods used shall also be reported. If methods other than EPA-approved methods or Standard Methods are used, the exact methodology must be submitted for review and must be approved by the Regional Board prior to use.
- d. The Discharger shall establish chain-of-custody procedures to insure that specific individuals are responsible for sample integrity from commencement of sample collection through delivery to an approved laboratory. Sample collection, storage, and analysis shall be conducted in accordance with an approved Sampling and Analysis Plan (SAP). The most recent version of the approved SAP shall be kept at the facility.
- e. The Discharger shall calibrate and perform maintenance procedures on all monitoring instruments and equipment to ensure accuracy of measurements, or shall insure that both activities will be conducted. The calibration of any wastewater flow measuring device shall be recorded and maintained in the permanent log book described in 2.b, below.
- f. A grab sample is defined as an individual sample collected in fewer than 15 minutes.

##### 2. **OPERATIONAL REQUIREMENTS**

###### a. Sample Results

Pursuant to California Water Code Section 13267(b), the Discharger shall

maintain all sampling and analytical results including: strip charts; date, exact place, and time of sampling; date analyses were performed; sample collector's name; analyst's name; analytical techniques used; and results of all analyses. Such records shall be retained for a minimum of three years.

This period of retention shall be extended during the course of any unresolved litigation regarding this discharge, or when requested by the Regional Board.

b. Operational Log

Pursuant to California Water Code Section 13267(b), an operation and maintenance log shall be maintained at the facility. All monitoring and reporting data shall be recorded in a permanent log book.

3. REPORTING

- a. For every item where the requirements are not met, the Discharger shall submit a statement of the actions undertaken or proposed which will bring the discharge into full compliance with requirements at the earliest time, and shall submit a timetable for correction.
- b. Pursuant to California Water Code Section 13267(b), all sampling and analytical results shall be made available to the Regional Board upon request. Results shall be retained for a minimum of three years. This period of retention shall be extended during the course of any unresolved litigation regarding this discharge, or when requested by the Regional Board.
- c. The Discharger shall provide a brief summary of any operational problems and maintenance activities to the Board with each monitoring report. Any modifications or additions to, or any major maintenance conducted on, or any major problems occurring to the wastewater conveyance system, treatment facilities, or disposal facilities shall be included in this summary.
- d. Monitoring reports shall be signed by Facility operator.
- e. Monitoring reports are to include the following:
  - i. Name and telephone number of individual who can answer questions about the report.
  - ii. The Monitoring and Reporting Program Number.
  - iii. WDID Number.
- f. Modifications

This Monitoring and Reporting Program may be modified at the discretion of the Regional Board Executive Officer.

4. NONCOMPLIANCE

Under Section 13268 of the Water Code, any person failing or refusing to furnish technical or monitoring reports, or falsifying any information provided therein, is guilty of a misdemeanor and may be liable civilly in an amount of up to one thousand dollars (\$1,000) for each day of violation under Section 13268 of the Water Code.



**c) Reported Value(s) or Volume:**

---

---

**d) WDRs/NPDES  
Limit/Condition:**

---

---

**e) Date(s) and Duration of  
Violation(s):**

---

---

**f) Explanation of Cause(s):**

---

---

---

---

**g) Corrective Action(s)  
(Specify actions taken and a schedule  
for actions to be taken)**

---

---

---

---

---

I certify under penalty of law that this document and all attachments were prepared under my direction or supervision following a system designed to ensure that qualified personnel properly gather and evaluate the information submitted. Based on my knowledge of the person(s) who manage the system, or those directly responsible for data gathering, the information submitted is, to the best of my knowledge and belief, true, accurate, and complete. I am aware that there are significant penalties for submitting false information, including the possibility of fine and imprisonment.

If you have any questions or require additional information, please contact \_\_\_\_\_ at the number provided above. Sincerely,

Signature: \_\_\_\_\_

Name: \_\_\_\_\_

Title: \_\_\_\_\_