

CALIFORNIA REGIONAL WATER QUALITY CONTROL BOARD
LAHONTAN REGION

MEETING OF JULY 23-24, 2008
TRUCKEE

ITEM: 6

SUBJECT: UPDATED WASTE DISCHARGE REQUIREMENTS AND
NATIONAL POLLUTANT DISCHARGE ELIMINATION SYSTEM
FOR THE SUSANVILLE SANITARY DISTRICT WASTEWATER
TREATMENT FACILITY, LASSEN COUNTY

CHRONOLOGY:

<u>Date</u>	<u>Action</u>
May 8, 2002	Water Board adopted updated requirements allowing facility expansion.

ISSUES: Are waste discharge requirements for the Susanville Sanitary District (Discharger) adequate to protect water quality from the continued discharge of treated wastewater to an irrigation channel that flows to Jensen Slough, a water of the United States?

DISCUSSION: The Discharger treats and disinfects up to two million gallons of municipal wastewater per day before discharging into an irrigation channel that crosses several large ranches and connects to the Jensen Slough. The Jensen Slough is a controlled waterway that receives water diverted by the federal water master from the Susan River to irrigate private lands southeast of Susanville. The Jensen Slough may also receive some return inflow in the form of runoff from the irrigated lands that it serves (termed *tailwater*). The Jensen Slough also returns to the Susan River, a water of the United States, and so the Jensen Slough is considered a water of the U.S. by the "tributary rule" as defined in the Basin Plan. In accordance with the federal Clean Water Act, the point-source discharge of pollutants to Jensen Slough requires a National Discharge Elimination System (NPDES) Permit. The Discharger does not control the flow of wastewater after it enters the irrigation channel and has applied for reissued NPDES requirements for existing operations.

The nearest downstream location where numeric Water Quality Objectives (WQO) are established for the Susan River is at Litchfield, approximately 16 miles (by road) from the Discharger's facility. By the tributary rule, these standards are also applicable to the Jensen Slough. Discharge effluent concentrations for total dissolved solids (TDS), total nitrogen, total phosphorous, sulfate and boron are typically higher than the corresponding WQOs for the Susan River at Litchfield. This is a potential concern because there are times when the Jensen Slough may consist predominantly of treated effluent (a

06-0001

condition termed *effluent-dominated*). During winter, reclamation is generally not practiced, water from the Susan River is not being diverted to Jensen Slough, and most of the wastewater flows to Jensen Slough. Effluent dominated flows in Jensen Slough may, but are not likely to occur in the late summer and early fall, when diversions from the Susan River to the Jensen Slough are low, irrigation usage is high, and tailwater runoff is low. During these hot, dry times there is high demand for the Discharger's treated wastewater to irrigate in supplement to Jensen Slough water, such that the treated water is typically used up and no discharge to Jensen Slough occurs.

Past monitoring requirements have been insufficient to determine whether excursions above WQOs due to the discharge have occurred in Jensen Slough, or have caused adverse impacts to the beneficial uses for its waters. Similarly, staff can not determine if the discharge has potential to cause the Jensen Slough to exceed WQOs, other than during periods of effluent dominated flows. The proposed Order includes significantly revised monitoring requirements for monitoring the effluent and the receiving water (Jensen Slough), both in terms of concentrations and flow rates so as to better evaluate water quality conditions during different flow regimes.

The ranchers who use the recycled water have been doing so since 1971 or earlier. Consistent with previous Orders, this Order does not include reclamation requirements for the Discharger pursuant to California Code of Regulations title 22 regulations for reuse of treated wastewater. Previous waste discharge requirements included disinfection to assure Basin Plan WQOs for total coliform were met. The proposed updated permit carries these disinfection requirements forward, but the wastewater is not required (by title 22) to be disinfected for the current agricultural uses (stock fodder and water). (Also, the Water Board has not required the users of the treated wastewater to file waste discharge reports for reclamation uses, a typical precursor to the imposition of reclamation requirements by the Water Board. Ranchers may work together informally to manage the wastewater. It is presently not known if all of the irrigation water is used prior to making it to the Jensen Slough because this is not monitored.)

In summary, the current uses of the discharge have been occurring for several decades and available information does not indicate that this has resulted in impairments to water quality or beneficial uses of the receiving waters. The proposed Order modifies and increases the surface water monitoring to assist in determining whether the discharge is adversely affecting the receiving water. There is no immediate alternative available to the Discharger for the disposal of the treated effluent. Potential future actions by the Water Board may

1) include requiring the Discharger to evaluate use of existing storage facilities and new on- or off-site storage facilities to eliminate the winter discharge to surface water, and 2) developing reclamation requirements for the Discharger (and/or the ranchers receiving the Discharger's wastewater).

Public notice of the availability of a draft NPDES Permit, a planned public meeting to consider adoption, and opportunities to comment were placed in the Lassen County Times. Tentative requirements were mailed out to the Discharger and interested parties for comments on May 7, 2008, with a request for written comments by June 6, 2008. No written comments were received. Staff met with the Discharger to discuss the requirements on June 6, 2008, and incorporated minor changes to the Order.

RECOMMENDATION: Adoption of the Order as proposed.

Enclosure: 1. Proposed Board Order, with Fact Sheet

ENCLOSURE 1

06-0004

CALIFORNIA REGIONAL WATER QUALITY CONTROL BOARD

LAHONTAN REGION

2501 Lake Tahoe Blvd.
South Lake Tahoe, CA 96150
Phone (530) 542 - 5400 • Fax (530) 542 - 2271
<http://www.waterboards.ca.gov>

**ORDER NO. R6T-2008-(PROPOSED)
NPDES NO. CA0102695**

**WASTE DISCHARGE REQUIREMENTS FOR THE
SUSANVILLE SANITARY DISTRICT, WASTEWATER TREATMENT PLANT
DISCHARGE TO THE JENSEN SLOUGH VIA OUTFALL 001**

The following Discharger is subject to waste discharge requirements as set forth in this Order:

Table 1. Discharger Information

Discharger	Susanville Sanitary District
Name of Facility	Wastewater Treatment Plant
Facility Address	476-200 Paul Bunyan Road
	Susanville, CA 96130
	Lassen County
The U.S. Environmental Protection Agency (USEPA) and the California Regional Water Quality Control Board, Lahontan Region (Lahontan Water Board) have classified this discharge as a <u>major</u> discharge.	

The discharge by the Susanville Sanitary District from the discharge points identified below is subject to waste discharge requirements as set forth in this Order:

Table 2. Discharge Location

Discharge Point	Effluent Description	Discharge Point Latitude	Discharge Point Longitude	Receiving Water
001 (JA-1)	Dechlorinated wastewater effluent	40°, 24', 50" N	120°, 37', 0" W	Jensen Slough

Table 3. Administrative Information

This Order was adopted by the Lahontan Water Board on:	July 23, 2008
This Order shall become effective on:	August 22, 2008
This Order shall expire on:	July 23, 2013
The Discharger shall file a Report of Waste Discharge in accordance with title 23, California Code of Regulations, as application for issuance of new waste discharge requirements no later than:	180 days prior to the Order expiration date

I, Harold J. Singer, Executive Officer, do hereby certify that this Order with all attachments is a full, true, and correct copy of an Order adopted by the California Regional Water Quality Control Board, Lahontan Region, on July 23, 2008.

Harold J. Singer, Executive Officer

06-0005

Table of Contents

I.	Facility Information	3
II.	Findings	3
III.	Discharge Prohibitions	10
IV.	Effluent Limitations and Discharge Specifications	11
	A. Effluent Limitations – Discharge Point 001	11
	C. Land Discharge Specifications – Not Applicable	12
V.	Receiving Water Limitations	12
	A. Surface Water Limitations	12
	B. Groundwater Limitations	17
VI.	Provisions	17
	A. Standard Provisions	18
	B. Monitoring and Reporting Program (MRP) Requirements	18
	C. Special Provisions	18
	1. Reopener Provisions	18
	2. Special Studies, Technical Reports and Additional Monitoring Requirements	18
	3. Best Management Practices and Pollution Prevention	20
	4. Construction, Operation and Maintenance Specifications	21
	5. Special Provisions for Municipal Facilities (POTWs Only)	21
	6. Other Special Provisions – Not Applicable	22
7.	Compliance Schedules – Not Applicable	22
VII.	Compliance Determination	22

List of Tables

Table 1.	Discharger Information	1
Table 2.	Discharge Location	1
Table 3.	Administrative Information	1
Table 4.	Facility Information	3
Table 5.	Basin Plan Beneficial Uses	5
Table 6.	Ground Water Basin Plan Beneficial Uses	6
Table 7.	Final Effluent Limitations	12
Table 8.	Receiving Water Limitations	13

List of Attachments

Attachment A –	Definitions	A-1
Attachment B –	Map	B-1
Attachment C –	Flow Schematic and Site Map	C-1
Attachment D –	Standard Provisions	D-1
Attachment E –	Monitoring and Reporting Program (MRP)	E-1
Attachment F –	Fact Sheet	F-1
Attachment G –	List of Priority Pollutants	G-1
Attachment H –	State Water Board Minimum Levels	H-1
Attachment I –	Cover sheet	I-1

I. FACILITY INFORMATION

The following Discharger is subject to waste discharge requirements as set forth in this Order:

Table 4. Facility Information

Discharger	Susanville Sanitary District
Name of Facility	Wastewater Treatment Facility, Susanville
Facility Address	476-200 Bunyan Road
	Susanville, CA 96130
	Lassen County
Facility Contact, Title, and Phone	Randy O'Hern, General Manager, (530) 257 - 5665
Mailing Address	45 S. Roop Street P.O. Box 152 Susanville, CA 96130
Type of Facility	Publicly Owned Treatment Works
Facility Design Flow	2.0 Million Gallons per Day (MGD)

II. FINDINGS

The California Regional Water Quality Control Board, Lahontan Region (hereinafter Lahontan Water Board), finds:

A. Background. The Susanville Sanitary District (hereinafter Discharger) is currently discharging pursuant to Order No. R6T-2002-0031 and National Pollutant Discharge Elimination System (NPDES) Permit No. CA0102695. The Discharger submitted a Report of Waste Discharge, dated November 1, 2006, and applied for a NPDES permit renewal to discharge up to 2.0 MGD of treated wastewater from the Susanville Sanitary District Wastewater Treatment Plant, hereinafter Facility. The application was deemed complete on March 24, 2007.

For the purposes of this Order, references to the "discharger" or "permittee" in applicable federal and state laws, regulations, plans, or policy are held to be equivalent to references to the Discharger herein.

B. Facility Description. The Discharger owns and operates the wastewater treatment plant. The treatment system consists of screening, grit removal, extended aeration sludge processing, secondary clarification, disinfection and dechlorination processes. The treatment system also includes two emergency storage ponds that can receive wastewater from the influent distribution box or from the chlorine contact chamber box. The two emergency storage ponds are shown in Attachment C1 and C2 and may be used during system problems to store wastewater and return the wastewater back into the head works. The wastewater is discharged from a polishing wetland to an irrigation channel that crosses three separate ranches not under the ownership or control of the Discharger.

Each ranch flood irrigates using water from both the wastewater irrigation channel and from Jensen Slough. The Jensen Slough is considered a water of the United States, and a tributary to the Susan River. Tail water from irrigation practice, which may be a mixture of water from Jensen slough and treated effluent, is returned to Jensen Slough for use at the next ranch. At the third property the wastewater combined with Jensen slough water is used for irrigation or the combined flow goes to the Susan River, which is where the Jensen Slough terminates. Attachment B provides a map of the area around the Facility. Attachment C provides a flow schematic of the Facility.

- C. Legal Authorities.** This Order is issued pursuant to section 402 of the federal Clean Water Act (CWA) and implementing regulations adopted by the U.S. Environmental Protection Agency (USEPA) and chapter 5.5, division 7 of the California Water Code (commencing with section 13370). It shall serve as a NPDES permit for point source discharges from this facility to surface waters. This Order also serves as Waste Discharge Requirements (WDRs) pursuant to article 4, chapter 4, division 7 of the Water Code (commencing with section 13260).
- D. Background and Rationale for Requirements** The Lahontan Water Board developed the requirements in this Order based on information submitted as part of the application, through monitoring and reporting programs, and other available information. The Fact Sheet (Attachment F), which contains background information and rationale for Order requirements, is hereby incorporated into this Order and constitutes part of the Findings for this Order. Attachment A through I are also incorporated into this Order.
- E. California Environmental Quality Act (CEQA).** Under Water Code section 13389, this action to adopt an NPDES permit is exempt from the provisions of CEQA, Public Resources Code sections 21100-21177.
- F. Technology-Based Effluent Limitations.** Section 301(b) of the CWA and implementing USEPA permit regulations at section 122.44, title 40 of the Code of Federal Regulations¹, require that permits include conditions meeting applicable technology-based requirements at a minimum, and any more stringent effluent limitations necessary to meet applicable water quality standards. The discharge authorized by this Order must meet minimum federal technology-based requirements based on Secondary Treatment Standards at Part 133. A detailed discussion of the technology-based effluent limitations development is included in the Fact Sheet.
- G. Water Quality-Based Effluent Limitations.** Section 301(b) of the CWA and section 122.44(d) require that permits include limitations more stringent than applicable federal technology-based requirements where necessary to achieve applicable water quality standards.

Section 122.44(d)(1)(i) mandates that permits include effluent limitations for all pollutants that are or may be discharged at levels that have the reasonable potential to cause or contribute to an exceedance of a water quality standard, including numeric and narrative objectives within a standard. Where reasonable potential has been established for a pollutant, but there is no numeric criterion or objective for the pollutant,

¹ All further statutory references are to title 40 of the Code of Federal Regulations unless otherwise indicated.

water quality-based effluent limitations (WQBELs) must be established using: (1) USEPA criteria guidance under CWA section 304(a), supplemented where necessary by other relevant information; (2) an indicator parameter for the pollutant of concern; or (3) a calculated numeric water quality criterion, such as a proposed state criterion or policy interpreting the state's narrative criterion, supplemented with other relevant information, as provided in section 122.44(d)(1)(vi).

H. Water Quality Control Plans. The Lahontan Water Board adopted a Water Quality Control Plan for the Lahontan Region on March 31, 1995 that designates beneficial uses, establishes water quality objectives, and contains implementation programs and policies to achieve those objectives for all waters addressed through the plan. The Basin Plan on page 2-3 states that the beneficial uses of any specifically identified water body generally apply to its tributary streams. The Basin Plan does not specifically identify beneficial uses for the Jensen Slough, but does identify present and potential uses for the Susan River, to which the Jensen Slough, is tributary. Because the Jensen Slough is tributary to the Susan River, this permit continues to use the water quality objectives for the Susan River at Litchfield based on the Basin Plan's "tributary rule," which provides that water quality standards for specific waterbodies apply upstream to tributaries for which no site-specific standards have been adopted."

These beneficial uses are: municipal and domestic supply, agricultural supply, industrial supply, ground water recharge, freshwater replenishment, navigation, water-contact recreation, non-contact water recreation, commercial and sport fishing, warm freshwater habitat, cold freshwater habitat, wildlife habitat, migration of aquatic organisms, spawning, reproduction and development. In addition, the Basin Plan implements State Water Resources Control Board (State Water Board) Resolution No. 88-63, which established state policy that all waters, with certain exceptions, should be considered suitable or potentially suitable for municipal or domestic supply. Thus, as discussed in detail in the Fact Sheet, beneficial uses applicable to the Jensen Slough are as follows:

Table 5. Basin Plan Beneficial Uses

Discharge Point	Receiving Water Name	Beneficial Use(s)
001	Jensen Slough	<u>Existing:</u> Municipal and domestic water supply (MUN); Agricultural supply (AGR); Industrial supply (IND); Ground water recharge (GWR); Freshwater replenishment (FRSH); Navigation (NAV); contact (REC-1) and non-contact (REC-2) water recreation; Commercial and sportfishing (COMM); Warm freshwater habitat (WARM); Cold freshwater habitat (COLD); Wildlife habitat (WILD); Migration of aquatic organisms (MIGR); Spawning, reproduction and development (SPWN).

The Basin Plan also identifies beneficial uses of ground water at page 4.6-1 that are applicable to all subsurface waters in the Lahontan Region. Beneficial uses of specific ground water basins in the Lahontan Region are designated in Table 2-2 of the Basin Plan. The Facility is located within the Honey Lake Ground Water Basin. Unless otherwise designated by the Lahontan Water Board, all ground waters are considered suitable, or potentially suitable, for municipal or domestic water supply (MUN).

Table 6. Ground Water Basin Plan Beneficial Uses

Basin Name	Beneficial Use(s)
Honey Lake Ground Water Basin	Beneficial Uses; <u>Existing:</u> Municipal and domestic water supply (MUN); Agricultural supply (AGR); Industrial supply (IND); Freshwater replenishment (FRSH); Wildlife habitat (WILD);

Requirements of this Order implement the Basin Plan.

On June 28, 2007 USEPA gave final approval to California's 2006 section 303(d) List of Water Quality Limited Segments. The Susan River is listed as an impaired water body for toxicity pursuant to Section 303(d) of the Clean Water Act. US EPA testing in 1990 on the Susan River identified toxicity to larval fish and the aquatic plant, duckweed. The cause(s) of toxicity were not identified.

The Susan River was placed on the federal Clean Water Act, Section 303(d) list of impaired water bodies for unknown toxicity. While the toxicity observed in the Susan River samples is a violation of the Lahontan Basin Plan narrative water quality objective for toxicity, potential impacts of the toxicity results on biological communities in the Susan River is incompletely known. The Susan River will continue to be 303(d)-listed for "unknown toxicity", but a TMDL is not currently recommended as the appropriate regulatory response since the pollutant(s) causing toxicity has not been decisively identified.

I. National Toxics Rule (NTR) and California Toxics Rule (CTR). USEPA adopted the NTR on December 22, 1992, and later amended it on May 4, 1995 and November 9, 1999. About forty criteria in the NTR applied in California. On May 18, 2000, USEPA adopted the CTR. The CTR promulgated new toxics criteria for California and, in addition, incorporated the previously adopted NTR criteria that were applicable in the state. The CTR was amended on February 13, 2001. These rules contain water quality criteria for priority pollutants.

J. State Implementation Policy. On March 2, 2000, the State Water Board adopted the *Policy for Implementation of Toxics Standards for Inland Surface Waters, Enclosed Bays, and Estuaries of California* (State Implementation Policy or SIP). The SIP became effective on April 28, 2000 with respect to the priority pollutant criteria promulgated for California by the USEPA through the NTR and to the priority pollutant objectives established by the Lahontan Water Board in the Basin Plan. The SIP became effective on May 18, 2000 with respect to the priority pollutant criteria promulgated by the USEPA through the CTR. The State Water Board adopted amendments to the SIP on February 24, 2005 that became effective on July 13, 2005. The SIP establishes implementation provisions for priority pollutant criteria and objectives and provisions for chronic toxicity control. Requirements of this Order implement the SIP.

K. Compliance Schedules and Interim Requirements. Section 2.1 of the SIP provides that, based on a Discharger's request and demonstration that it is infeasible for an existing Discharger to achieve immediate compliance with an effluent limitation derived from a CTR criterion, compliance schedules may be allowed in an NPDES permit. Unless an exception has been granted under section 5.3 of the SIP, a compliance schedule may not exceed 5 years from the date that the permit is issued or reissued, nor may it extend beyond 10 years from the effective date of the SIP (or May 18, 2010) to establish and comply with CTR criterion-based effluent limitations. Where a compliance schedule for a final effluent limitation exceeds 1 year, the Order must include interim numeric limitations for that constituent or parameter. Where allowed by the Lahontan Water Board, compliance schedules and interim effluent limitations or discharge specifications may also be granted to allow time to implement a new or revised water quality objective. This Order does not include compliance schedules and interim effluent limitations.

L. Alaska Rule. On March 30, 2000, USEPA revised its regulation that specifies when new and revised state and tribal water quality standards (WQS) become effective for CWA purposes. (40 C.F.R. § 131.21; 65 Fed. Reg. 24641 (April 27, 2000).) Under the revised regulation (also known as the Alaska rule), new and revised standards submitted to USEPA after May 30, 2000, must be approved by USEPA before being used for CWA purposes. The final rule also provides that standards already in effect and submitted to USEPA by May 30, 2000 may be used for CWA purposes, whether or not approved by USEPA.

M. Stringency of Requirements for Individual Pollutants. This Order contains both technology-based and water quality-based effluent limitations for individual pollutants. The technology-based effluent limitations consist of restrictions on biological oxygen demand, suspended solids and pH. These restrictions are discussed in the Fact Sheet, section IV.B.2. This Order's technology-based pollutant restrictions implement the minimum, applicable federal technology-based requirements.

Water quality-based effluent limitations have been scientifically derived to implement water quality objectives that protect beneficial uses. Both the beneficial uses and the water quality objectives have been approved pursuant to federal law and are the applicable federal water quality standards. To the extent that toxic pollutant water quality-based effluent limitations were derived from the CTR, the CTR is the applicable standard pursuant to section 131.38. The scientific procedures for calculating the individual water quality-based effluent limitations for priority pollutants are based on the CTR-SIP, which was approved by USEPA on May 18, 2000. All beneficial uses and water quality objectives contained in the Basin Plan were approved under state law and submitted to and approved by USEPA prior to May 30, 2000. Any water quality objectives and beneficial uses submitted to USEPA prior to May 30, 2000, but not approved by USEPA before that date, are nonetheless "applicable water quality standards for purposes of the CWA" pursuant to section 131.21(c)(1). Collectively, this Order's restrictions on individual pollutants are no more stringent than required to implement the requirements of the CWA.

This Order contains pollutant restrictions that are more stringent than applicable federal requirements and standards. Specifically, this Order includes effluent limitations for pH that are more stringent than applicable federal standards, but that are nonetheless necessary to meet numeric objectives or protect beneficial uses. The rationale for including these limitations is explained in the Fact Sheet section IV.C.3.

- N. Antidegradation Policy.** Section 131.12 requires that the state water quality standards include an antidegradation policy consistent with the federal policy. The State Water Board established California's antidegradation policy in State Water Board Resolution No. 68-16. Resolution No. 68-16 incorporates the federal antidegradation policy where the federal policy applies under federal law. Resolution No. 68-16 requires that existing quality of waters be maintained unless degradation is justified based on specific findings. The Lahontan Water Board's Basin Plan implements, and incorporates by reference, both the state and federal antidegradation policies. As discussed in detail in the Fact Sheet the permitted discharge is consistent with the antidegradation provision of section 131.12 and State Water Board Resolution No. 68-16.
- O. Anti-Backsliding Requirements.** Sections 402(o)(2) and 303(d)(4) of the CWA and federal regulations at title 40, Code of Federal Regulations section 122.44(l) prohibit backsliding in NPDES permits. These anti-backsliding provisions require effluent limitations in a reissued permit to be as stringent as those in the previous permit, with some exceptions where limitations may be relaxed. All effluent limitations in this Order are at least as stringent as the effluent limitations in the previous Order.
- P. Monitoring and Reporting.** Section 122.48 requires that all NPDES permits specify requirements for recording and reporting monitoring results. Water Code sections 13267 and 13383 authorizes the Lahontan Water Board to require technical and monitoring reports. The Monitoring and Reporting Program establishes monitoring and reporting requirements to implement federal and State requirements. This Monitoring and Reporting Program is provided in Attachment E.
- Q. Standard and Special Provisions.** Standard Provisions, which apply to all NPDES permits in accordance with section 122.41, and additional conditions applicable to specified categories of permits in accordance with section 122.42, are provided in Attachment D. The discharger must comply with all standard provisions and with those additional conditions that are applicable under section 122.42. The Lahontan Water Board has also included in this Order special provisions applicable to the Discharger. A rationale for the special provisions contained in this Order is provided in the attached Fact Sheet.
- R. Provisions and Requirements Implementing State Law.** The provisions/requirements in subsections IV.B, IV.C, V.B, and VI.C. of this Order are included to implement state law only. These provisions/requirements are not required or authorized under the federal CWA; consequently, violations of these provisions/requirements are not subject to the enforcement remedies that are available for NPDES violations.

- S. Notification of Interested Parties.** The Lahontan Water Board has notified the Discharger and interested agencies and persons of its intent to prescribe Waste Discharge Requirements for the discharge and has provided them with an opportunity to submit their written comments and recommendations. Details of notification are provided in the Fact Sheet of this Order.
- T. Consideration of Public Comment.** The Lahontan Water Board, in a public meeting, heard and considered all comments pertaining to the discharge. Details of the Public Hearing are provided in the Fact Sheet of this Order.

PROPOSED

IT IS HEREBY ORDERED, that Order No. R6T-2002-0031 is rescinded upon the effective date of this Order except for enforcement purposes, and, in order to meet the provisions contained in division 7 of the Water Code (commencing with section 13000) and regulations adopted thereunder, and the provisions of the federal Clean Water Act (CWA) and regulations and guidelines adopted thereunder, the Discharger shall comply with the requirements in this Order.

III. DISCHARGE PROHIBITIONS

A. General Requirements and Prohibitions

1. The discharge of wastewater, except to the authorized disposal site (001 as described in this Order) and to the emergency storage ponds, is prohibited.
2. There shall be no discharge, bypass, or diversion of raw or partially treated wastewater, wastewater sludge, grease, or oils from the collection, transport, treatment, emergency storage, or disposal facilities to adjacent land areas, or surface waters.
3. All facilities used for collection, transport, treatment, or disposal of waste shall be adequately protected against overflow, washout or inundation from a storm, or flood having a recurrence interval of once of in 100 years.
4. Waste organic sludge shall be discharged only at a legal point of disposal in accordance with the provisions of Title 23, Division 3, Chapter 15 and Title 27, section 20220 (c) of the California Code of Regulations.
5. The discharge shall not cause pollution, or a threatened pollution as defined by Section 13050(l) of California Water Code.
6. The collection, transport, treatment, storage, or discharge of waste shall not cause a nuisance as defined by Section 13050(m) of California Water Code.

B. Emergency Storage Ponds

1. The discharge of untreated or partially treated wastewater to the emergency storage ponds is prohibited, except when any of the following occur:
 - a. Loss of electrical power at the wastewater treatment facility;
 - b. Major equipment failure at the wastewater treatment facility;
 - c. Wastewater treatment process upset;
 - d. Excessive infiltration/inflow into sewerage facilities;
 - e. Any other emergency that could threaten the public health;

- f. Vacuum truck wastes are discharged from maintenance or spills;
 - g. For routine maintenance of the chlorine contact chamber; or
 - h. Emergency maintenance activities upon written approval of Lahontan Water Board Executive Officer.
2. The Discharger shall notify Lahontan Water Board staff by telephone as soon as it or its agents have knowledge of any discharge in any single continuous event in excess of 10,000 gallons of untreated or partially treated wastewater to the emergency storage basin, and confirm this notification in writing within one week of the telephone notification. The written notification shall contain pertinent information explaining reasons for the discharge, and indicating steps taken, and dates thereof, to correct the problem and prevent it from reoccurring. An estimate of the amount of flow discharged should also be included.
 3. The Discharger must, as soon as is practicable, treat the wastes discharged into the emergency storage ponds by pumping the waste back into the treatment system for treatment prior to being discharged to Jensen slough.

IV. EFFLUENT LIMITATIONS AND DISCHARGE SPECIFICATIONS

A. Effluent Limitations – Discharge Point 001

1. Final Effluent Limitations – Discharge Point 001

- a. The rate of flow from the facility averaged for any month must not be more than 2.0 million gallons per day (MGD).
- b. The effluent must not contain trace elements, pollutants, contaminants, or combinations thereof, in concentrations which are toxic or harmful to human, aquatic, terrestrial plant or animal life.
- c. The Discharger shall maintain compliance with the following effluent limitations at Discharge Point 001, with compliance measured described in Attachment E, Table E-3:

Table 7. Final Effluent Limitations

Parameter	Units	Effluent Limitations				
		Average Monthly	Average Weekly	Maximum Daily	Instantaneous Minimum	Instantaneous Maximum
Daily Effluent Flow	MGD	2.0	---	---	---	---
Biochemical Oxygen Demand (BOD) (5-day @ 20 Deg. C)	mg/L	30	45	---	---	---
	Lbs/day ¹	500	751	---	---	---
Total Suspended Solids (TSS)	mg/L	30	45	---	---	---
	Lbs/day ¹	500	751	---	---	---
pH	pH units	---	---	---	6.5	8.5
Removal Efficiency for BOD and TSS	%	85	---	---	---	---
Residual Chlorine	mg/L	0.01	---	---	---	0.02

“---” No effluent limitation is applicable.

¹ The mass-based effluent limitations are based on a design capacity of 2.0 MGD.

2. Effluent Limitation within the treatment system EFF-002

The Discharger must meet the California Code of Federal Regulations, Title 22 for “Disinfected secondary-23 recycled water,” recycled water that has been oxidized and disinfected so that the median concentration of total coliform bacteria in the disinfected effluent does not exceed a most probable number (MPN) of 23 per 100 milliliters utilizing the bacteriological results of the last seven days for which analyses have been completed, and the number of total coliform bacteria does not exceed an MPN of 240 per 100 milliliters in more than one sample in any 30 day period.

3. Interim Effluent Limitations – Not Applicable

C. Land Discharge Specifications – Not Applicable

D. Reclamation Specifications – Not Applicable

V. RECEIVING WATER LIMITATIONS

A. Surface Water Limitations

1. The surface water receiving water limitations in the proposed Order are based upon the water quality objectives contained in the Basin Plan and are carried forward from the previous Order. As such, they are a required part of the proposed Order.
2. The discharge shall not cause the following limits to be exceeded in the Susan River and its tributaries:

Table 8. Receiving Water Limitations

Parameter	Units	Receiving Water Limitation	
		Annual Mean	Maximum
Total Dissolved Solids	mg/L	185	250
Chloride	mg/L	4.2	7.5
Total Nitrogen	mg/L	0.65	0.85
Total Phosphorus	mg/L	0.25	0.30
Sulfate	mg/L	25	40
Un-ionized Ammonia	mg/L	--	0.025
Boron	mg/L	0.1	0.2
Adjusted Sodium Adsorption Ratio (calculated)	N/A	2.5	--

3. If the constituent concentration of the receiving water just above the discharge point exceeds the level in Table 7, the discharge must not cause a statistically significant increase (at a 90 percent confidence level) in the concentration below the discharge point when compared to the concentration upstream of the discharge.
4. Water Quality Objectives Which Apply to All Surface Waters: these narrative and numerical water quality objectives apply to all surface waters (including wetlands) within the Lahontan Region and can be found at section 3-3 of the Basin Plan. The discharge to surface waters of flows generated within, or as a result of, the Facility shall not cause a violation of the following water quality objectives for the waters of the Susan River Hydrologic Area:

Ammonia: The neutral, unionized ammonia species (NH_3) is highly toxic to freshwater fish. The fraction of toxic NH_3 to total ammonia species ($\text{NH}_4^+ + \text{NH}_3$) is a function of temperature and pH. Ammonia concentrations shall not exceed the values listed for the corresponding conditions in the table 3-1 through 3-4 of the Basin Plan. For temperature and pH values not explicitly in these tables, the most conservative value neighboring the actual value may be used or criteria can be calculated from numerical formulas developed by the USEPA.

Bacteria, Coliform: Waters shall not contain concentrations of coliform organisms attributable to anthropogenic sources, including human and livestock wastes. The fecal coliform concentration during any 30-day period shall not exceed a log mean of 20 MPN per 100 ml, nor shall more than 10 percent of all samples collected during any 30-day period exceed 40 MPN per 100 ml. *The log mean shall ideally be based on a minimum of not less than five samples collected as evenly spaced as practicable during any 30-day period. However, a log mean concentration exceeding 20 MPN per 100 ml for any 30-day period shall indicate violation of this objective even if fewer than five samples were collected.*

Biostimulatory Substances: Waters shall not contain biostimulatory substances in concentrations that promote aquatic growths to the extent that such growths cause nuisance or adversely affect the water for beneficial uses.

Chemical Constituents: Waters designated as MUN shall not contain concentrations of chemical constituents in excess of the maximum contaminant level (MCL) or secondary maximum contaminant level (SMCL) based upon drinking water standards specified in the following provisions in the California Code of Regulations Title 22, Division 4, Chapter 15 in the following Articles: Article 4 - Inorganic Chemicals, Article 4, section 644422.2 - Fluoride, Article 5.5 - Organic Chemicals, and Article 16- both the Secondary Maximum Contaminant Levels Consumer Acceptance Limits and Secondary Maximum Contaminant Levels-Ranges. This incorporation-by-reference is prospective including future changes to the incorporated provisions as the changes take effect.

Waters designated as AGR shall not contain concentrations of chemical constituents in amounts that adversely affect the water for beneficial uses (i.e., agricultural purposes).

Waters shall not contain concentrations of chemical constituents in amounts that adversely affect the water for beneficial uses.

Chlorine, Total Residual: For the protection of aquatic life, total chlorine residual shall not exceed either a median value of 0.002 mg/L or a maximum value of 0.003 mg/L in the receiving water. Median values shall be based on daily measurements taken within any six-month period.

Color: Waters shall be free of coloration that causes nuisance or adversely affects the water for beneficial uses.

Dissolved Oxygen: The dissolved oxygen concentration, as percent saturation, shall not be depressed by more than 10 percent, nor shall the minimum dissolved oxygen concentration be less than 80 percent of saturation. For waters with the beneficial uses of COLD, COLD with SPWN, WARM, and WARM with SPWN, the minimum dissolved oxygen concentration shall not be less than that specified in Table 3-6 of the Basin Plan.

Floating Materials: Waters shall not contain floating material, including solids, liquids, foams, and scum, in concentrations that cause nuisance or adversely affect the water for beneficial uses.

For natural high quality waters, the concentrations of floating material shall not be altered to the extent that such alterations are discernable at the 10 percent significance level.

Oil and Grease: Waters shall not contain oils, greases, waxes or other materials in concentrations that result in a visible film or coating on the surface of the water or on

objects in the water, that cause nuisance, or that otherwise adversely affect the water for beneficial uses.

For natural high quality waters, the concentration of oils, greases, or other film or coat generating substances shall not be altered.

Non-degradation of Aquatic Communities and Populations: All wetlands shall be free from substances attributable to wastewater or other discharges that produce adverse physiological responses in humans, animals, or plants; or which lead to the presence of undesirable or nuisance aquatic life.

All wetlands shall be free from activities that would substantially impair the biological community as it naturally occurs due to physical, chemical and hydrologic processes.

Pesticides: For the purposes of this Basin Plan, pesticides are defined to include insecticides, herbicides, rodenticides, fungicides, piscicides and all other economic poisons. An economic poison is any substance intended to prevent, repel, destroy, or mitigate the damage from insects, rodents, predatory animals, bacteria, fungi or weeds capable of infesting or harming vegetation, humans, or animals (California Food & Agricultural Code § 12754.5).

Pesticide concentrations, individually or collectively, shall not exceed the lowest detectable levels, using the most recent detection procedures available. There shall not be an increase in pesticide concentrations found in bottom sediments. There shall be no detectable increase in bioaccumulation of pesticides in aquatic life.

Waters designated as MUN shall not contain concentrations of pesticides or herbicides in excess of the limiting concentrations specified in the California Code of Regulation Title 22, Division 4, Chapter 15, Article 5.5 -Organic Chemicals is incorporated by reference into this order. This incorporation-by-reference is prospective including future changes to the incorporated provisions as the changes take effect.

pH: In fresh waters with designated beneficial uses of COLD or WARM, changes in normal ambient pH levels shall not exceed 0.5 pH units. For all other waters of the Region, the pH shall not be depressed below 6.5 nor raised above 8.5.

The Lahontan Water Board recognizes that some waters of the Region may have natural pH levels outside of the 6.5 to 8.5 range. Compliance with the pH objective for these waters will be determined on a case-by case basis.

Radioactivity: Radionuclides shall not be present in concentrations which are deleterious to human, plant, animal, or aquatic life nor which result in the accumulation of radionuclides in the food web to an extent which presents a hazard to human, plant, animal, or aquatic life.

Waters designated as MUN shall not contain concentrations of radionuclides in excess of the limits specified in the California Code of Regulations Title 22, Division 4, Chapter 15, Article 5, which is incorporated by reference into this order. This incorporation-by-reference is prospective including future changes to the incorporated provisions as the changes take effect.

Sediment: The suspended sediment load and suspended sediment discharge rate of surface waters shall not be altered in such a manner as to cause nuisance or adversely affect the water for beneficial uses.

Settleable Materials: Waters shall not contain substances in concentrations that result in deposition of material that causes nuisance or that adversely affects the water for beneficial uses. For natural high quality waters, the concentration of settleable materials shall not be raised by more than 0.1 milliliter per liter.

Suspended Materials: Waters shall not contain suspended materials in concentrations that cause nuisance or that adversely affects the water for beneficial uses.

For natural high quality waters, the concentration of total suspended materials shall not be altered to the extent that such alterations are discernible at the 10 percent significance level.

Taste and Odor: Waters shall not contain taste or odor-producing substances in concentrations that impart undesirable tastes or odors to fish or other edible products of aquatic origin, that cause nuisance, or that adversely affect the water for beneficial uses. For naturally high quality waters, the taste and odor shall not be altered.

Temperature: The natural receiving water temperature of all waters shall not be altered unless it can be demonstrated to the satisfaction of the Lahontan Water Board that such an alteration in temperature does not adversely affect the water for beneficial uses.

For waters designated WARM, water temperature shall not be altered by more than five degrees Fahrenheit (5°F) above or below the natural temperature. For waters designated COLD, the temperature shall not be altered.

Toxicity: All waters shall be maintained free of toxic substances in concentrations that are toxic to, or that produce detrimental physiological responses in human, plant, animal, or aquatic life. *Compliance with this objective will be determined by use of indicator organisms, analyses of species diversity, population density, growth anomalies, bioassays of appropriate duration and/or other appropriate methods as specified by the Lahontan Water Board.*

The survival of aquatic life in surface waters subjected to a waste discharge, or other controllable water quality factors, shall not be less than that for the same water body in areas unaffected by the waste discharge, or when necessary, for other control

water that is consistent with the requirements for "experimental water" as defined in the most recent edition of *Standard Methods for the Examination of Water and Wastewater* (American Public Health Association, et al.).

Turbidity: Waters shall be free of changes in turbidity that cause nuisance or adversely affect the water for beneficial uses. Increases in turbidity shall not exceed natural levels by more than 10 percent.

B. Groundwater Limitations

1. The ground water limitations in the proposed Order are based upon the water quality objectives contained in the Basin Plan and are carried forward from the previous Order. As such, they are a required part of the proposed Order.
2. The discharge shall not cause a violation of the following water quality objectives for the waters of the Honey Lake Valley Ground Water Basin (Dept. of Water Resource Basin No. 6-4):

Bacteria, Coliform: In ground waters designated as MUN, the median concentration of coliform organisms over any 7-day period shall be less than 1.1 MPN per 100 ml.

Chemical Constituents: Waters designated as MUN shall not contain concentrations of chemical constituents in excess of the maximum contaminant level (MCL) or secondary maximum contaminant level (SMCL) based upon drinking water standards specified in the following provisions in the California Code of Regulations Title 22, Division 4, Chapter 15 in the following Articles: Article 4 - Inorganic Chemicals, Article 4, section 644422.2 - Fluoride, Article 5.5 - Organic Chemicals, and Article 16- both the Secondary Maximum Contaminant Levels Consumer Acceptance Limits and Secondary Maximum Contaminant Levels-Ranges. This incorporation-by-reference is prospective including future changes to the incorporated provisions as the changes take effect.

Ground waters shall not contain concentrations of chemical constituents in amounts that adversely affect the water for beneficial uses.

Radioactivity: Ground waters designated as MUN shall not contain concentrations of radionuclides in excess of the limits specified in the California Code of Regulations Title 22, Division 4, Chapter 15, Article 5 Radioactivity.

Tastes and Odors: Ground waters shall not contain taste or odor-producing substances in concentrations that cause nuisance or that adversely affect beneficial uses. For ground waters designated as MUN, at a minimum, concentrations shall not exceed adopted secondary maximum contaminant levels specified in the California Code of Regulations, Title 22, Division 4, Chapter 15, Article 16.

VI. PROVISIONS

A. Standard Provisions

- 1. Federal Standard Provisions.** Standard Provisions, which apply to all NPDES permits in accordance with section 122.41, and additional conditions applicable to specified categories of permits in accordance with section 122.42, are provided in Attachment D. The Discharger must comply with all standard provisions and with those additional conditions that are applicable under section 122.42.

Section 122.41(a)(1) and (b) through (n) establish conditions that apply to all State-issued NPDES permits. These conditions must be incorporated into the permits either expressly or by reference. If incorporated by reference, a specific citation to the regulations must be included in the Order. Section 123.25(a)(12) allows the state to omit or modify conditions to impose more stringent requirements. In accordance with section 123.25, this Order omits federal conditions that address enforcement authority specified in sections 122.41(j)(5) and (k)(2) because the enforcement authority under the Water Code is more stringent. In lieu of these conditions, this Order incorporates by reference Water Code section 13387(e).

- 2. Water Board Standard Provisions – Not Applicable**

B. Monitoring and Reporting Program (MRP) Requirements

The Discharger shall comply with the MRP, and future revisions thereto, in Attachment E of this Order.

C. Special Provisions

- 1. Reopener Provisions**

This Order may be reopened for modification, or revocation and reissuance, as a result of the detection of a reportable priority pollutant generated by special conditions included in this Order. These special conditions may be, but are not limited to, fish tissue sampling, whole effluent toxicity, monitoring requirements on internal waste stream(s), and monitoring for surrogate parameters. Additional requirements may be included in this Order as a result of the special condition monitoring data.

- 2. Special Studies, Technical Reports and Additional Monitoring Requirements**

Toxicity Reduction Requirements

If the discharge causes or contributes to chronic toxicity in the receiving water, a Toxicity Reduction Evaluation (TRE) as defined in Attachment A shall be required. The Lahontan Water Board shall require the Discharger to conduct a TRE if repeated tests reveal toxicity as a result of waste discharge under this Order. The Discharger shall take all reasonable steps to control toxicity once the source of toxicity is identified. Failure to conduct the required toxicity tests or a TRE may result in reopening this Order to establish effluent limitations for chronic toxicity, and/or enforcement action as authorized by law.

PROPOSED

3. Best Management Practices and Pollution Prevention

a. Pollutant Minimization Program

The Discharger shall develop and conduct a Pollutant Minimization Program (PMP) as further described below when there is evidence (e.g., sample results reported as DNQ when the effluent limitation is less than the MDL, sample results from analytical methods more sensitive than those methods required by this Order, presence of whole effluent toxicity, health advisories for fish consumption, results of benthic or aquatic organism tissue sampling) that a priority pollutant is present in the effluent above an effluent limitation and either:

- i. A sample result is reported as DNQ and the effluent limitation is less than the RL; or
- ii. A sample result is reported as ND and the effluent limitation is less than the MDL, using definitions described in Attachment A and reporting protocols described in MRP section X.B.4.

b. The PMP shall include, but not be limited to, the following actions and submittals acceptable to the Lahontan Water Board.

- i. An annual review and semi-annual monitoring of potential sources of the reportable priority pollutant(s), which may include fish tissue monitoring and other bio-uptake sampling;
- ii. Quarterly monitoring for the reportable priority pollutant(s) in the influent to the wastewater treatment system;
- iii. Submittal of a control strategy designed to proceed toward the goal of maintaining concentrations of the reportable priority pollutant(s) in the effluent at or below the effluent limitation;
- iv. Implementation of appropriate cost-effective control measures for the reportable priority pollutant(s), consistent with the control strategy; and
- v. An annual status report that shall be sent to the Lahontan Water Board including:
 - (a) All PMP monitoring results for the previous year;
 - (b) A list of potential sources of the reportable priority pollutant(s);
 - (c) A summary of all actions undertaken pursuant to the control strategy; and
 - (d) A description of actions to be taken in the following year.

4. Construction, Operation and Maintenance Specifications

- a. The Discharger's wastewater treatment facility shall be supervised by people who possess a wastewater treatment plant operator certificate of appropriate grade pursuant to the California Code of Regulations, Title 23, Division 3, Chapter 26, Article 3.
- b. Infiltration/inflow into sewerage facilities from stormwater or nuisance water shall be minimized to the maximum extent practicable.
- c. All facilities used for collection, transportation, treatment, or disposal of waste shall be adequately protected against overflow, washout, inundation, structural damage or a significant reduction in efficiency resulting from a storm or flood having a recurrence interval of once in 100 years.

5. Special Provisions for Municipal Facilities (POTWs Only)

- a. Pretreatment Specifications – Not Applicable
- b. Sludge/Biosolids Disposal
 - i. Pursuant to 40 CFR part 503.1 the Discharger is a public owned treatment works that has a design flow of greater than 1 MGD and is subject to record keeping associated with removed biosolids/sewage sludge.
 - ii. The Discharger must maintain a permanent log of all solids and biosolids hauled away from the treatment facility for use or disposal elsewhere. The log shall include a summary of the volume, type (screening, grit, raw sludge, and digested sludge), use (agricultural, composting, etc.) and destination in accordance with the monitoring and reporting program of this Order.
 - iii. Collected screenings, biosolids, and other solids removed from liquid wastes shall be disposed of in a manner that is consistent with State Water Resources Control Board and Integrated Waste Management Board's joint regulations (Title 27) of the CCR.
 - iv. The Discharger shall submit to the Lahontan Water Board a copy of the annual biosolids report required to be submitted to USEPA, if one is prepared pursuant to 40 CFR Part 503.
- c. The Discharger's collection system is part of the system that is subject to this Order. As such, the Discharger must properly operate and maintain its collection system (40 C.F.R. § 122.41(e)). The Discharger must report any non-compliance (40 C.F.R. § 122.41(l)(6) and (7)) and mitigate any discharge from the collection system in violation of this Order (40 C.F.R. § 122.41(d)). See Attachment D, subsections I.D, V.E, V.H, and I.C.

6. Other Special Provisions – Not Applicable

7. Compliance Schedules – Not Applicable

VII. COMPLIANCE DETERMINATION

Compliance with the effluent limitations contained in section IV of this Order will be determined as specified below:

A. General.

Compliance with effluent limitations for priority pollutants shall be determined using sample reporting protocols defined in the MRP and Attachment A of this Order. For purposes of reporting and administrative enforcement by the Regional and State Water Boards, the Discharger shall be deemed out of compliance with effluent limitations if the concentration of the priority pollutant in the monitoring sample is greater than the effluent limitation and greater than or equal to the reporting level (RL).

B. Multiple Sample Data.

When determining compliance with an AMEL, AWEL, or MDEL for priority pollutants and more than one sample result is available, the Discharger shall compute the arithmetic mean unless the data set contains one or more reported determinations of "Detected, but Not Quantified" (DNQ) or "Not Detected" (ND). In those cases, the Discharger shall compute the median in place of the arithmetic mean in accordance with the following procedure:

1. The data set shall be ranked from low to high, ranking the reported ND determinations lowest, DNQ determinations next, followed by quantified values (if any). The order of the individual ND or DNQ determinations is unimportant.
2. The median value of the data set shall be determined. If the data set has an odd number of data points, then the median is the middle value. If the data set has an even number of data points, then the median is the average of the two values around the middle unless one or both of the points are ND or DNQ, in which case the median value shall be the lower of the two data points where DNQ is lower than a value and ND is lower than DNQ.

C. Average Monthly Effluent Limitation (AMEL).

If the average (or when applicable, the median determined by subsection B above for multiple sample data) of daily discharges over a calendar month exceeds the AMEL for a given parameter, this will represent a single violation, though the Discharger will be considered out of compliance for each day of that month for that parameter (e.g., resulting in 31 days of non-compliance in a 31-day month). If only a single sample is taken during the calendar month and the analytical result for that sample exceeds the AMEL, the Discharger will be considered out of compliance for that calendar month. The Discharger will only be considered out of compliance for days when the discharge occurs. For any one calendar month during which no sample (daily discharge) is taken, no compliance determination can be made for that calendar month.

D. Average Weekly Effluent Limitation (AWEL).

If the average (or when applicable, the median determined by subsection B above for multiple sample data) of daily discharges over a calendar week exceeds the AWEL for a given parameter, this will represent a single violation, though the Discharger will be considered out of compliance for each day of that week for that parameter, resulting in 7 days of non-compliance. If only a single sample is taken during the calendar week and the analytical result for that sample exceeds the AWEL, the Discharger will be considered out of compliance for that calendar week. The Discharger will only be considered out of compliance for days when the discharge occurs. For any one calendar week during which no sample (daily discharge) is taken, no compliance determination can be made for that calendar week.

E. Maximum Daily Effluent Limitation (MDEL).

If a daily discharge (or when applicable, the median determined by subsection B above for multiple sample data of a daily discharge) exceeds the MDEL for a given parameter, the Discharger will be considered out of compliance for that parameter for that 1 day only within the reporting period. For any 1 day during which no sample is taken, no compliance determination can be made for that day.

F. Instantaneous Minimum Effluent Limitation.

If the analytical result of a single grab sample is lower than the instantaneous minimum effluent limitation for a parameter, the Discharger will be considered out of compliance for that parameter for that single sample. Non-compliance for each sample will be considered separately (e.g., the results of two grab samples taken within a calendar day that both are lower than the instantaneous minimum effluent limitation would result in two instances of non-compliance with the instantaneous minimum effluent limitation).

G. Instantaneous Maximum Effluent Limitation.

If the analytical result of a single grab sample is higher than the instantaneous maximum effluent limitation for a parameter, the Discharger will be considered out of compliance for that parameter for that single sample. Non-compliance for each sample will be considered separately (e.g., the results of two grab samples taken within a calendar day that both exceed the instantaneous maximum effluent limitation would result in two instances of non-compliance with the instantaneous maximum effluent limitation).

ATTACHMENT A

06-0028

ATTACHMENT A – DEFINITIONS

Arithmetic Mean (μ), also called the average, is the sum of measured values divided by the number of samples. For ambient water concentrations, the arithmetic mean is calculated as follows:

Arithmetic mean = $\mu = \Sigma x / n$ where: Σx is the sum of the measured ambient water concentrations, and n is the number of samples.

Average Monthly Effluent Limitation (AMEL): the highest allowable average of daily discharges over a calendar month, calculated as the sum of all daily discharges during a calendar month divided by the number of daily discharges measured during that month.

Average Weekly Effluent Limitation (AWEL): the highest allowable average of daily discharges over a calendar week (Sunday through Saturday), calculated as the sum of all daily discharges during a calendar week divided by the number of daily discharges measured during that week.

Bioaccumulative pollutants are those substances taken up by an organism from its surrounding medium through gill membranes, epithelial tissue, or from food and subsequently concentrated and retained in the body of the organism.

Carcinogenic pollutants are substances that are known to cause cancer in living organisms.

Coefficient of Variation (CV) is a measure of the data variability and is calculated as the estimated standard deviation divided by the arithmetic mean of the observed values.

Daily Discharge: Daily Discharge is defined as either: (1) the total mass of the constituent discharged over the calendar day (12:00 am through 11:59 pm) or any 24-hour period that reasonably represents a calendar day for purposes of sampling (as specified in the permit), for a constituent with limitations expressed in units of mass or; (2) the unweighted arithmetic mean measurement of the constituent over the day for a constituent with limitations expressed in other units of measurement (e.g., concentration).

The daily discharge may be determined by the analytical results of a composite sample taken over the course of one day (a calendar day or other 24-hour period defined as a day) or by the arithmetic mean of analytical results from one or more grab samples taken over the course of the day.

For composite sampling, if 1 day is defined as a 24-hour period other than a calendar day, the analytical result for the 24-hour period will be considered as the result for the calendar day in which the 24-hour period ends.

Detected, but Not Quantified (DNQ) are those sample results less than the RL, but greater than or equal to the laboratory's MDL.

Dilution Credit is the amount of dilution granted to a discharge in the calculation of a water quality-based effluent limitation, based on the allowance of a specified mixing zone. It is calculated from the dilution ratio or determined through conducting a mixing zone study or modeling of the discharge and receiving water.

Effluent Concentration Allowance (ECA) is a value derived from the water quality criterion/objective, dilution credit, and ambient background concentration that is used, in conjunction with the coefficient of variation for the effluent monitoring data, to calculate a long-term average (LTA) discharge concentration. The ECA has the same meaning as waste load allocation (WLA) as used in U.S. EPA guidance (Technical Support Document For Water Quality-based Toxics Control, March 1991, second printing, EPA/505/2-90-001).

Enclosed Bays means indentations along the coast that enclose an area of oceanic water within distinct headlands or harbor works. Enclosed bays include all bays where the narrowest distance between the headlands or outermost harbor works is less than 75 percent of the greatest dimension of the enclosed portion of the bay. Enclosed bays include, but are not limited to, Humboldt Bay, Bodega Harbor, Tomales Bay, Drake's Estero, San Francisco Bay, Morro Bay, Los Angeles-Long Beach Harbor, Upper and Lower Newport Bay, Mission Bay, and San Diego Bay. Enclosed bays do not include inland surface waters or ocean waters.

Estimated Chemical Concentration is the estimated chemical concentration that results from the confirmed detection of the substance by the analytical method below the ML value.

Estuaries means waters, including coastal lagoons, located at the mouths of streams that serve as areas of mixing for fresh and ocean waters. Coastal lagoons and mouths of streams that are temporarily separated from the ocean by sandbars shall be considered estuaries. Estuarine waters shall be considered to extend from a bay or the open ocean to a point upstream where there is no significant mixing of fresh water and seawater. Estuarine waters included, but are not limited to, the Sacramento-San Joaquin Delta, as defined in Water Code section 12220, Suisun Bay, Carquinez Strait downstream to the Carquinez Bridge, and appropriate areas of the Smith, Mad, Eel, Noyo, Russian, Klamath, San Diego, and Otay rivers. Estuaries do not include inland surface waters or ocean waters.

Inland Surface Waters are all surface waters of the State that do not include the ocean, enclosed bays, or estuaries.

Instantaneous Maximum Effluent Limitation: the highest allowable value for any single grab sample or aliquot (i.e., each grab sample or aliquot is independently compared to the instantaneous maximum limitation).

Instantaneous Minimum Effluent Limitation: the lowest allowable value for any single grab sample or aliquot (i.e., each grab sample or aliquot is independently compared to the instantaneous minimum limitation).

Maximum Daily Effluent Limitation (MDEL) means the highest allowable daily discharge of a pollutant, over a calendar day (or 24-hour period). For pollutants with limitations expressed in units of mass, the daily discharge is calculated as the total mass of the pollutant discharged over the day. For pollutants with limitations expressed in other units of measurement, the daily discharge is calculated as the arithmetic mean measurement of the pollutant over the day.

Median is the middle measurement in a set of data. The median of a set of data is found by first arranging the measurements in order of magnitude (either increasing or decreasing order). If the number of measurements (n) is odd, then the median = $X_{(n+1)/2}$. If n is even, then the median = $(X_{n/2} + X_{(n/2)+1})/2$ (i.e., the midpoint between the $n/2$ and $n/2+1$).

Method Detection Limit (MDL) is the minimum concentration of a substance that can be measured and reported with 99 percent confidence that the analyte concentration is greater than zero, as defined in title 40 of the Code of Federal Regulations, Part 136, Attachment B, revised as of July 3, 1999.

Minimum Level (ML) is the concentration at which the entire analytical system must give a recognizable signal and acceptable calibration point. The ML is the concentration in a sample that is equivalent to the concentration of the lowest calibration standard analyzed by a specific analytical procedure, assuming that all the method specified sample weights, volumes, and processing steps have been followed.

Mixing Zone is a limited volume of receiving water that is allocated for mixing with a wastewater discharge where water quality criteria can be exceeded without causing adverse effects to the overall water body.

Not Detected (ND) are those sample results less than the laboratory's MDL.

Ocean Waters are the territorial marine waters of the State as defined by California law to the extent these waters are outside of enclosed bays, estuaries, and coastal lagoons. Discharges to ocean waters are regulated in accordance with the State Water Board's California Ocean Plan.

Persistent pollutants are substances for which degradation or decomposition in the environment is nonexistent or very slow.

Pollutant Minimization Program (PMP) means waste minimization and pollution prevention actions that include, but are not limited to, product substitution, waste stream recycling, alternative waste management methods, and education of the public and businesses. The goal of the PMP shall be to reduce all potential sources of a priority pollutant(s) through pollutant minimization (control) strategies, including pollution prevention measures as appropriate, to maintain the effluent concentration at or below the water quality-based effluent limitation. Pollution prevention measures may be particularly appropriate for persistent bioaccumulative priority pollutants where there is evidence that beneficial uses are being impacted. The Lahontan Water Board may consider cost effectiveness when establishing the requirements of a PMP. The completion and implementation of a Pollution Prevention Plan, if required pursuant to Water Code section 13263.3(d), shall be considered to fulfill the PMP requirements.

Pollution Prevention means any action that causes a net reduction in the use or generation of a hazardous substance or other pollutant that is discharged into water and includes, but is not limited to, input change, operational improvement, production process change, and product reformulation (as defined in Water Code section 13263.3). Pollution prevention does not include actions that merely shift a pollutant in wastewater from one environmental medium to

another environmental medium, unless clear environmental benefits of such an approach are identified to the satisfaction of the State or Lahontan Water Board.

Reporting Level (RL) is the ML (and its associated analytical method) chosen by the Discharger for reporting and compliance determination from the MLs included in this Order. The MLs included in this Order correspond to approved analytical methods for reporting a sample result that are selected by the Lahontan Water Board either from Appendix 4 of the SIP in accordance with section 2.4.2 of the SIP or established in accordance with section 2.4.3 of the SIP. The ML is based on the proper application of method-based analytical procedures for sample preparation and the absence of any matrix interferences. Other factors may be applied to the ML depending on the specific sample preparation steps employed. For example, the treatment typically applied in cases where there are matrix-effects is to dilute the sample or sample aliquot by a factor of ten. In such cases, this additional factor must be applied to the ML in the computation of the RL.

Satellite Collection System is the portion, if any, of a sanitary sewer system owned or operated by a different public agency than the agency that owns and operates the wastewater treatment facility that a sanitary sewer system is tributary to.

Source of Drinking Water is any water designated as municipal or domestic supply (MUN) in the Lahontan Water Board Basin Plan.

Standard Deviation (σ) is a measure of variability that is calculated as follows:

$$\sigma = \left(\frac{\sum[(x - \mu)^2]}{(n - 1)} \right)^{0.5}$$

where:

x is the observed value;

μ is the arithmetic mean of the observed values; and

n is the number of samples.

Toxicity Reduction Evaluation (TRE) is a study conducted in a step-wise process designed to identify the causative agents of effluent or ambient toxicity, isolate the sources of toxicity, evaluate the effectiveness of toxicity control options, and then confirm the reduction in toxicity.

The first steps of the TRE consist of the collection of data relevant to the toxicity, including additional toxicity testing, and an evaluation of facility operations and maintenance practices, and best management practices. A Toxicity Identification Evaluation (TIE) may be required as part of the TRE, if appropriate. (A TIE is a set of procedures to identify the specific chemical(s) responsible for toxicity. These procedures are performed in three phases (characterization, identification, and confirmation) using aquatic organism toxicity tests.)

ATTACHMENT B

06-0033

ATTACHMENT C

06-0035

ATTACHMENT C1 - FLOW SCHEMATIC

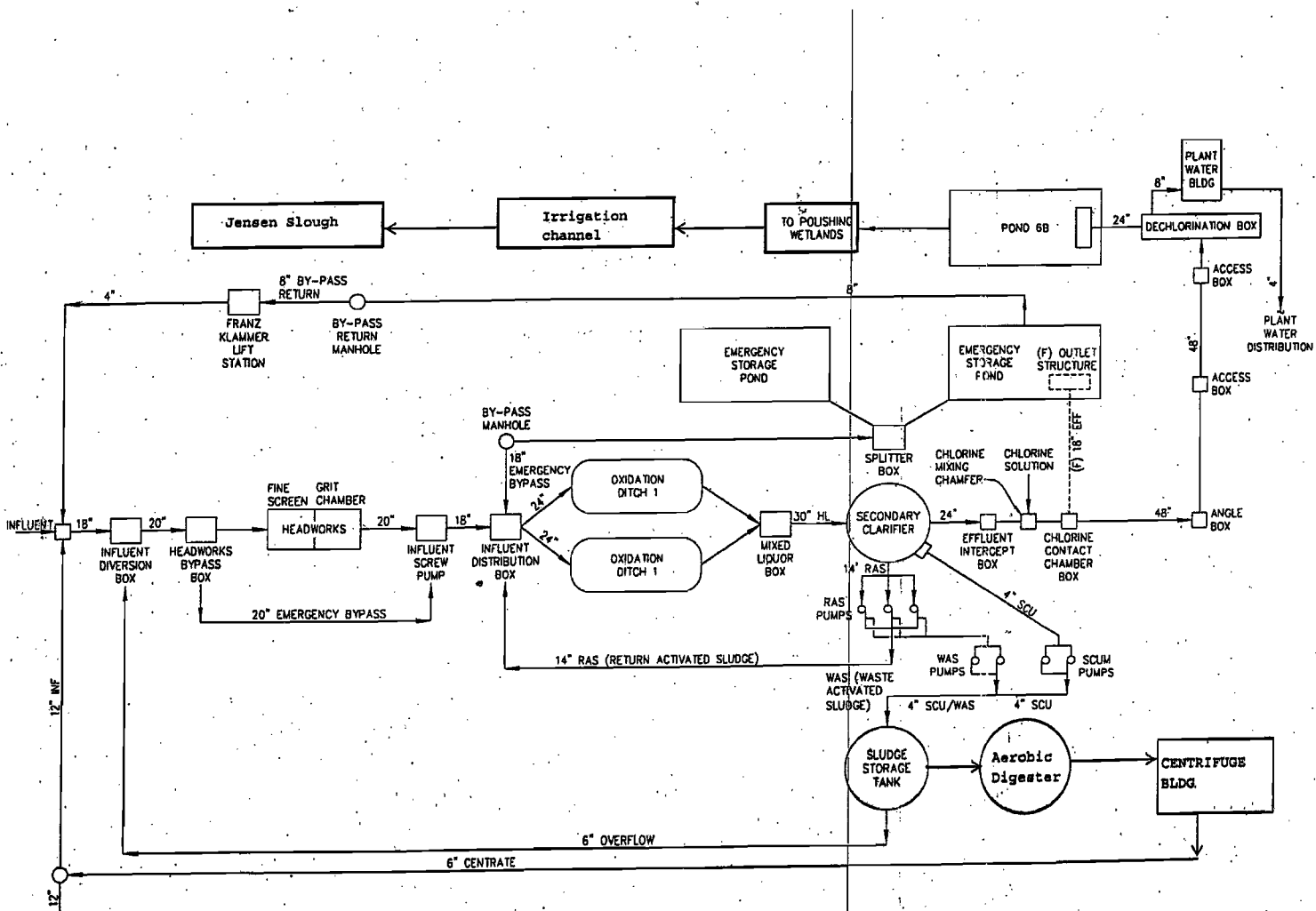

ATTACHMENT C2 - SITE MAP

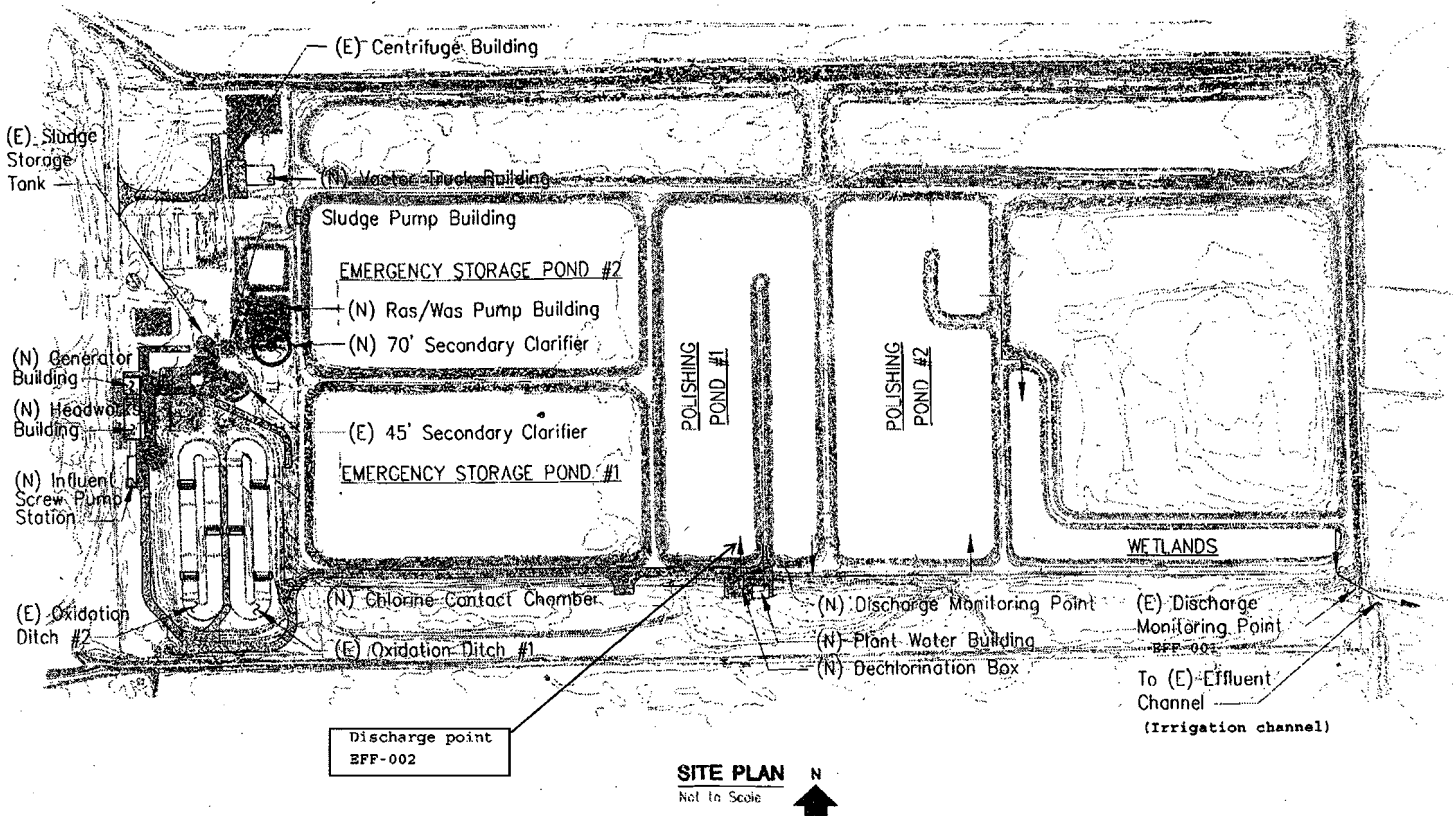

Discharge point
BFF-002

SITE PLAN
Not to Scale



(E) Existing
(N) New after completion of 2002

ATTACHMENT D

06-0038

ATTACHMENT D – STANDARD PROVISIONS

I. STANDARD PROVISIONS – PERMIT COMPLIANCE

A. Duty to Comply

1. The Discharger must comply with all of the conditions of this Order. Any noncompliance constitutes a violation of the Clean Water Act (CWA) and the California Water Code and is grounds for enforcement action, for permit termination, revocation and reissuance, or modification; or denial of a permit renewal application. (40 C.F.R. § 122.41(a).)
2. The Discharger shall comply with effluent standards or prohibitions established under Section 307(a) of the CWA for toxic pollutants and with standards for sewage sludge use or disposal established under Section 405(d) of the CWA within the time provided in the regulations that establish these standards or prohibitions, even if this Order has not yet been modified to incorporate the requirement. (40 C.F.R. § 122.41(a)(1).)

B. Need to Halt or Reduce Activity Not a Defense

It shall not be a defense for a Discharger in an enforcement action that it would have been necessary to halt or reduce the permitted activity in order to maintain compliance with the conditions of this Order. (40 C.F.R. § 122.41(c).)

C. Duty to Mitigate

The Discharger shall take all reasonable steps to minimize or prevent any discharge or sludge use or disposal in violation of this Order that has a reasonable likelihood of adversely affecting human health or the environment. (40 C.F.R. § 122.41(d).)

D. Proper Operation and Maintenance

The Discharger shall at all times properly operate and maintain all facilities and systems of treatment and control (and related appurtenances) which are installed or used by the Discharger to achieve compliance with the conditions of this Order. Proper operation and maintenance also includes adequate laboratory controls and appropriate quality assurance procedures. This provision requires the operation of backup or auxiliary facilities or similar systems that are installed by a Discharger only when necessary to achieve compliance with the conditions of this Order. (40 C.F.R. § 122.41(e).)

E. Property Rights

1. This Order does not convey any property rights of any sort or any exclusive privileges. (40 C.F.R. § 122.41(g).)
2. The issuance of this Order does not authorize any injury to persons or property or invasion of other private rights, or any infringement of state or local law or regulations. (40 C.F.R. § 122.5(c).)

F. Inspection and Entry

The Discharger shall allow the Lahontan Water Board, State Water Board, United States Environmental Protection Agency (USEPA), and/or their authorized representatives (including an authorized contractor acting as their representative), upon the presentation of credentials and other documents, as may be required by law, to (40 C.F.R. § 122.41(i); Water. Code, § 13383):

1. Enter upon the Discharger's premises where a regulated facility or activity is located or conducted, or where records are kept under the conditions of this Order (40 C.F.R. § 122.41(i)(1));
2. Have access to and copy, at reasonable times, any records that must be kept under the conditions of this Order (40 C.F.R. § 122.41(i)(2));
3. Inspect and photograph, at reasonable times, any facilities, equipment (including monitoring and control equipment), practices, or operations regulated or required under this Order (40 C.F.R. § 122.41(i)(3)); and
4. Sample or monitor, at reasonable times, for the purposes of assuring Order compliance or as otherwise authorized by the CWA or the Water Code, any substances or parameters at any location. (40 C.F.R. § 122.41(i)(4).)

G. Bypass

1. Definitions

- a. "Bypass" means the intentional diversion of waste streams from any portion of a treatment facility. (40 C.F.R. § 122.41(m)(1)(i).)
- b. "Severe property damage" means substantial physical damage to property, damage to the treatment facilities, which causes them to become inoperable, or substantial and permanent loss of natural resources that can reasonably be expected to occur in the absence of a bypass. Severe property damage does not mean economic loss caused by delays in production. (40 C.F.R. § 122.41(m)(1)(ii).)

2. Bypass not exceeding limitations. The Discharger may allow any bypass to occur which does not cause exceedances of effluent limitations, but only if it is for essential maintenance to assure efficient operation. These bypasses are not subject to the provisions listed in Standard Provisions – Permit Compliance I.G.3, I.G.4, and I.G.5 below. (40 C.F.R. § 122.41(m)(2).)
3. Prohibition of bypass. Bypass is prohibited, and the Lahontan Water Board may take enforcement action against a Discharger for bypass, unless (40 C.F.R. § 122.41(m)(4)(i)):

- a. Bypass was unavoidable to prevent loss of life, personal injury, or severe property damage (40 C.F.R. § 122.41(m)(4)(i)(A));

- b. There were no feasible alternatives to the bypass, such as the use of auxiliary treatment facilities, retention of untreated wastes, or maintenance during normal periods of equipment downtime. This condition is not satisfied if adequate back-up equipment should have been installed in the exercise of reasonable engineering judgment to prevent a bypass that occurred during normal periods of equipment downtime or preventive maintenance (40 C.F.R. § 122.41(m)(4)(i)(B)); and
 - c. The Discharger submitted notice to the Lahontan Water Board as required under Standard Provisions – Permit Compliance I.G.5 below. (40 C.F.R. § 122.41(m)(4)(i)(C).)
4. The Lahontan Water Board may approve an anticipated bypass, after considering its adverse effects, if the Lahontan Water Board determines that it will meet the three conditions listed in Standard Provisions – Permit Compliance I.G.3 above. (40 C.F.R. § 122.41(m)(4)(ii).)
5. Notice
- a. Anticipated bypass. If the Discharger knows in advance of the need for a bypass, it shall submit a notice, if possible at least 10 days before the date of the bypass. (40 C.F.R. § 122.41(m)(3)(i).)
 - b. Unanticipated bypass. The Discharger shall submit notice of an unanticipated bypass as required in Standard Provisions - Reporting V.E below (24-hour notice). (40 C.F.R. § 122.41(m)(3)(ii).)

H. Upset

Upset means an exceptional incident in which there is unintentional and temporary noncompliance with technology based permit effluent limitations because of factors beyond the reasonable control of the Discharger. An upset does not include noncompliance to the extent caused by operational error, improperly designed treatment facilities, inadequate treatment facilities, lack of preventive maintenance, or careless or improper operation. (40 C.F.R. § 122.41(n)(1).)

1. Effect of an upset. An upset constitutes an affirmative defense to an action brought for noncompliance with such technology based permit effluent limitations if the requirements of Standard Provisions – Permit Compliance I.H.2 below are met. No determination made during administrative review of claims that noncompliance was caused by upset, and before an action for noncompliance, is final administrative action subject to judicial review. (40 C.F.R. § 122.41(n)(2).)
2. Conditions necessary for a demonstration of upset. A Discharger who wishes to establish the affirmative defense of upset shall demonstrate, through properly signed, contemporaneous operating logs or other relevant evidence that (40 C.F.R. § 122.41(n)(3)):

- a. An upset occurred and that the Discharger can identify the cause(s) of the upset (40 C.F.R. § 122.41(n)(3)(i));
 - b. The permitted facility was, at the time, being properly operated (40 C.F.R. § 122.41(n)(3)(ii));
 - c. The Discharger submitted notice of the upset as required in Standard Provisions – Reporting V.E.2.b below (24-hour notice) (40 C.F.R. § 122.41(n)(3)(iii)); and
 - d. The Discharger complied with any remedial measures required under Standard Provisions – Permit Compliance I.C above. (40 C.F.R. § 122.41(n)(3)(iv).)
3. Burden of proof. In any enforcement proceeding, the Discharger seeking to establish the occurrence of an upset has the burden of proof. (40 C.F.R. § 122.41(n)(4).)

II. STANDARD PROVISIONS – PERMIT ACTION

A. General

This Order may be modified, revoked and reissued, or terminated for cause. The filing of a request by the Discharger for modification, revocation and reissuance, or termination, or a notification of planned changes or anticipated noncompliance does not stay any Order condition. (40 C.F.R. § 122.41(f).)

B. Duty to Reapply

If the Discharger wishes to continue an activity regulated by this Order after the expiration date of this Order, the Discharger must apply for and obtain a new permit. (40 C.F.R. § 122.41(b).)

C. Transfers

This Order is not transferable to any person except after notice to the Lahontan Water Board. The Lahontan Water Board may require modification or revocation and reissuance of the Order to change the name of the Discharger and incorporate such other requirements as may be necessary under the CWA and the Water Code. (40 C.F.R. § 122.41(l)(3); § 122.61.)

III. STANDARD PROVISIONS – MONITORING

- A. Samples and measurements taken for the purpose of monitoring shall be representative of the monitored activity. (40 C.F.R. § 122.41(j)(1).)
- B. Monitoring results must be conducted according to test procedures under Part 136 or, in the case of sludge use or disposal, approved under Part 136 unless otherwise specified

in Part 503 unless other test procedures have been specified in this Order. (40 C.F.R. § 122.41(j)(4); § 122.44(i)(1)(iv).)

IV. STANDARD PROVISIONS – RECORDS

A. Except for records of monitoring information required by this Order related to the Discharger's sewage sludge use and disposal activities, which shall be retained for a period of at least five years (or longer as required by Part 503), the Discharger shall retain records of all monitoring information, including all calibration and maintenance records and all original strip chart recordings for continuous monitoring instrumentation, copies of all reports required by this Order, and records of all data used to complete the application for this Order, for a period of at least three (3) years from the date of the sample, measurement, report or application. This period may be extended by request of the Lahontan Water Board Executive Officer at any time. (40 C.F.R. § 122.41(j)(2).)

B. Records of monitoring information shall include:

1. The date, exact place, and time of sampling or measurements (40 C.F.R. § 122.41(j)(3)(i));
2. The individual(s) who performed the sampling or measurements (40 C.F.R. § 122.41(j)(3)(ii));
3. The date(s) analyses were performed (40 C.F.R. § 122.41(j)(3)(iii));
4. The individual(s) who performed the analyses (40 C.F.R. § 122.41(j)(3)(iv));
5. The analytical techniques or methods used (40 C.F.R. § 122.41(j)(3)(v)); and
6. The results of such analyses. (40 C.F.R. § 122.41(j)(3)(vi).)

C. Claims of confidentiality for the following information will be denied (40 C.F.R. § 122.7(b)):

1. The name and address of any permit applicant or Discharger (40 C.F.R. § 122.7(b)(1)); and
2. Permit applications and attachments, permits and effluent data. (40 C.F.R. § 122.7(b)(2).)

V. STANDARD PROVISIONS – REPORTING

A. Duty to Provide Information

The Discharger shall furnish to the Lahontan Water Board, State Water Board, or USEPA within a reasonable time, any information which the Lahontan Water Board, State Water Board, or USEPA may request to determine whether cause exists for modifying, revoking and reissuing, or terminating this Order or to determine compliance with this Order. Upon request, the Discharger shall also furnish to the Lahontan Water

Board, State Water Board, or USEPA copies of records required to be kept by this Order. (40 C.F.R. § 122.41(h); Water Code, § 13267.)

B. Signatory and Certification Requirements

1. All applications, reports, or information submitted to the Lahontan Water Board, State Water Board, and/or USEPA shall be signed and certified in accordance with Standard Provisions – Reporting V.B.2, V.B.3, V.B.4, and V.B.5 below. (40 C.F.R. § 122.41(k).)

2. All permit applications shall be signed as follows:

All permit applications shall be signed by either a principal executive officer or ranking elected official. For purposes of this provision, a principal executive officer of a federal agency includes: (i) the chief executive officer of the agency, or (ii) a senior executive officer having responsibility for the overall operations of a principal geographic unit of the agency (e.g., Regional Administrators of USEPA). (40 C.F.R. § 122.22(a)(3).)

3. All reports required by this Order and other information requested by the Lahontan Water Board, State Water Board, or USEPA shall be signed by a person described in Standard Provisions – Reporting V.B.2 above, or by a duly authorized representative of that person. A person is a duly authorized representative only if:

a. The authorization is made in writing by a person described in Standard Provisions – Reporting V.B.2 above (40 C.F.R. § 122.22(b)(1));

b. The authorization specifies either an individual or a position having responsibility for the overall operation of the regulated facility or activity such as the position of plant manager, operator of a well or a well field, superintendent, position of equivalent responsibility, or an individual or position having overall responsibility for environmental matters for the company. (A duly authorized representative may thus be either a named individual or any individual occupying a named position.) (40 C.F.R. § 122.22(b)(2)); and

c. The written authorization is submitted to the Lahontan Water Board and State Water Board. (40 C.F.R. § 122.22(b)(3).)

4. If an authorization under Standard Provisions – Reporting V.B.3 above is no longer accurate because a different individual or position has responsibility for the overall operation of the facility, a new authorization satisfying the requirements of Standard Provisions – Reporting V.B.3 above must be submitted to the Lahontan Water Board and State Water Board prior to or together with any reports, information, or applications, to be signed by an authorized representative. (40 C.F.R. § 122.22(c).)

5. Any person signing a document under Standard Provisions – Reporting V.B.2 or V.B.3 above shall make the following certification:

"I certify under penalty of law that this document and all attachments were prepared under my direction or supervision in accordance with a system designed to assure that qualified personnel properly gather and evaluate the information submitted. Based on my inquiry of the person or persons who manage the system or those persons directly responsible for gathering the information, the information submitted is, to the best of my knowledge and belief, true, accurate, and complete. I am aware that there are significant penalties for submitting false information, including the possibility of fine and imprisonment for knowing violations." (40 C.F.R. § 122.22(d).)

C. Monitoring Reports

1. Monitoring results shall be reported at the intervals specified in the Monitoring and Reporting Program (Attachment E) in this Order. (40 C.F.R. § 122.22(l)(4).)
2. Monitoring results must be reported on a Discharge Monitoring Report (DMR) form or forms provided or specified by the Lahontan Water Board or State Water Board for reporting results of monitoring of sludge use or disposal practices. (40 C.F.R. § 122.41(l)(4)(i).)
3. If the Discharger monitors any pollutant more frequently than required by this Order using test procedures approved under Part 136 or, in the case of sludge use or disposal, approved under Part 136 unless otherwise specified in Part 503, or as specified in this Order, the results of this monitoring shall be included in the calculation and reporting of the data submitted in the DMR or sludge reporting form specified by the Lahontan Water Board. (40 C.F.R. § 122.41(l)(4)(ii).)
4. Calculations for all limitations, which require averaging of measurements, shall utilize an arithmetic mean unless otherwise specified in this Order. (40 C.F.R. § 122.41(l)(4)(iii).)

D. Compliance Schedules

Reports of compliance or noncompliance with, or any progress reports on, interim and final requirements contained in any compliance schedule of this Order, shall be submitted no later than 14 days following each schedule date. (40 C.F.R. § 122.41(l)(5).)

E. Twenty-Four Hour Reporting

1. The Discharger shall report any noncompliance that may endanger health or the environment. Any information shall be provided orally within 24 hours from the time the Discharger becomes aware of the circumstances. A written submission shall also be provided within five (5) days of the time the Discharger becomes aware of the circumstances. The written submission shall contain a description of the noncompliance and its cause; the period of noncompliance, including exact dates and times, and if the noncompliance has not been corrected, the anticipated time it is expected to continue; and steps taken or planned to reduce, eliminate, and prevent reoccurrence of the noncompliance. (40 C.F.R. § 122.41(l)(6)(i).)

2. The following shall be included as information that must be reported within 24 hours under this paragraph (40 C.F.R. § 122.41(l)(6)(ii)):
 - a. Any unanticipated bypass that exceeds any effluent limitation in this Order. (40 C.F.R. § 122.41(l)(6)(ii)(A).)
 - b. Any upset that exceeds any effluent limitation in this Order. (40 C.F.R. § 122.41(l)(6)(ii)(B).)
3. The Lahontan Water Board may waive the above-required written report under this provision on a case-by-case basis if an oral report has been received within 24 hours. (40 C.F.R. § 122.41(l)(6)(iii).)

F. Planned Changes

The Discharger shall give notice to the Lahontan Water Board as soon as possible of any planned physical alterations or additions to the permitted facility. Notice is required under this provision only when (40 C.F.R. § 122.41(l)(1)):

1. The alteration or addition to a permitted facility may meet one of the criteria for determining whether a facility is a new source in section 122.29(b) (40 C.F.R. § 122.41(l)(1)(i)); or
2. The alteration or addition could significantly change the nature or increase the quantity of pollutants discharged. This notification applies to pollutants that are not subject to effluent limitations in this Order. (40 C.F.R. § 122.41(l)(1)(ii).)
3. The alteration or addition results in a significant change in the Discharger's sludge use or disposal practices, and such alteration, addition, or change may justify the application of permit conditions that are different from or absent in the existing permit, including notification of additional use or disposal sites not reported during the permit application process or not reported pursuant to an approved land application plan. (40 C.F.R. § 122.41(l)(1)(iii).)

G. Anticipated Noncompliance

The Discharger shall give advance notice to the Lahontan Water Board or State Water Board of any planned changes in the permitted facility or activity that may result in noncompliance with General Order requirements. (40 C.F.R. § 122.41(l)(2).)

H. Other Noncompliance

The Discharger shall report all instances of noncompliance not reported under Standard Provisions – Reporting V.C, V.D, and V.E above at the time monitoring reports are submitted. The reports shall contain the information listed in Standard Provision – Reporting V.E above. (40 C.F.R. § 122.41(l)(7).)

I. Other Information

When the Discharger becomes aware that it failed to submit any relevant facts in a permit application, or submitted incorrect information in a permit application or in any report to the Lahontan Water Board, State Water Board, or USEPA, the Discharger shall promptly submit such facts or information. (40 C.F.R. § 122.41(l)(8).)

VI. STANDARD PROVISIONS – ENFORCEMENT

- A. The Lahontan Water Board is authorized to enforce the terms of this permit under several provisions of the Water Code, including, but not limited to, sections 13385, 13386, and 13387.

VII. ADDITIONAL PROVISIONS – NOTIFICATION LEVELS

A. Publicly-Owned Treatment Works (POTWs)

All POTWs shall provide adequate notice to the Lahontan Water Board of the following (40 C.F.R. § 122.42(b)):

1. Any new introduction of pollutants into the POTW from an indirect discharger that would be subject to sections 301 or 306 of the CWA if it were directly discharging those pollutants (40 C.F.R. § 122.42(b)(1)); and
2. Any substantial change in the volume or character of pollutants being introduced into that POTW by a source introducing pollutants into the POTW at the time of adoption of the Order. (40 C.F.R. § 122.42(b)(2).)
3. Adequate notice shall include information on the quality and quantity of effluent introduced into the POTW as well as any anticipated impact of the change on the quantity or quality of effluent to be discharged from the POTW. (40 C.F.R. § 122.42(b)(3).)

ATTACHMENT E

06-0048

ATTACHMENT E – MONITORING AND REPORTING PROGRAM

Table of Contents

I.	General Monitoring Provisions	E-2
II.	Monitoring Locations	E-5
III.	Influent Monitoring Requirements	E-5
	A. Monitoring Location INF-001.....	E-5
IV.	Effluent Monitoring Requirements	E-6
	A. Monitoring Location EFF-001.....	E-6
	B. Monitoring Location EFF-002.....	E-7
V.	Whole Effluent Toxicity (WET) Testing Requirements	E-8
	A. Monitoring Requirements.....	E-8
	B. Acute WET Testing – Monitoring Location EFF-001.....	E-9
	C. Chronic WET Testing – Monitoring Location EFF-001.....	E-9
	D. Definition of Toxicity.....	E-10
	E. Reporting	E-11
VI.	Land Discharge Monitoring Requirements – Not Applicable	E-11
VII.	Reclamation Monitoring Requirements – Not Applicable	E-11
VIII.	Receiving Water Monitoring Requirements – Surface Water	E-11
	A. Monitoring Location RSW-001	E-11
	B. Monitoring Location RSW-002.....	E-12
	C. Visual Monitoring at RSW-001 and RSW-002	E-13
IX.	Other Monitoring Requirements	E-13
	A. Monitoring Location SLD-001 Sludge Monitoring.....	E-13
X.	Reporting Requirements	E-14
	A. General Monitoring and Reporting Requirements.....	E-14
	B. Self Monitoring Reports (SMRs).....	E-14
	C. Discharge Monitoring Reports (DMRs).....	E-16
	D. Other Reports	E-17

List of Tables

Table E-1.	Monitoring Station Locations	E-5
Table E-2.	Influent Monitoring INF-001	E-6
Table E-3.	Effluent Monitoring EFF-001	E-7
Table E-4.	Effluent Monitoring EFF-002.....	E-8
Table E-5a.	Receiving Water Monitoring Requirements RSW-001	E-12
Table E-5b.	Receiving Water Monitoring Requirements RSW-002	E-13
Table E-6.	Monitoring Periods and Reporting Schedule	E-15

ATTACHMENT E- MONITORING AND REPORTING PROGRAM (MRP)

40 CFR section 122.48 requires that all NPDES permits specify monitoring and reporting requirements. Water Code Section 13267 and 13383 also authorize the Lahontan Water Board to require technical and monitoring reports. Pursuant to Water Code Section 13267 and 13383, this MRP establishes monitoring and reporting requirements which implement the federal and California regulations.

I. GENERAL MONITORING PROVISIONS

A. Sampling and Analysis

1. All analyses shall be performed in accordance with the current edition(s) of the following documents:
 - a. Standard Methods for the Examination of Water and Wastewater
 - b. Methods for Chemical Analysis of Water and Wastes, EPA
2. All analyses shall be performed in a laboratory certified to perform such analyses by the California Department of Public Health or a laboratory approved by the Lahontan Water Board's Executive Officer. Specific methods of analysis must be identified on each laboratory report.
3. Any modifications to the above methods to eliminate known interferences shall be reported with the sample results. The methods used shall also be reported. If methods other than EPA approved methods or Standard Methods are used, the exact methodology must be submitted for review and must be approved by the Lahontan Water Board's Executive Officer prior to use.
4. The Discharger shall establish chain of custody procedures to insure that specific individuals are responsible for sample integrity from commencement of sample collection through delivery to an approved laboratory. Sample collection, storage, and analysis shall be conducted in accordance with an approved Sampling and Analysis Plan (SAP). The most recent version of the approved SAP shall be kept at the facility.
5. The Discharger shall calibrate and perform maintenance procedures on all monitoring instruments and equipment to ensure accuracy of measurements, or shall insure that both activities will be conducted. The calibration of any wastewater flow measuring device shall be recorded and maintained in a permanent log book.
6. A grab sample is defined as an individual sample collected in fewer than 15 minutes.
7. A composite sample is defined as a combination of no fewer than eight individual samples obtained over the specified sampling period at equal intervals. The volume of each individual sample shall be proportional to the discharge flow rate at the time of sampling. The sampling period shall equal the discharge period, or 24 hours, whichever period is shorter.

8. The Discharger must provide information on how the flow measurement is obtained at each location where flow monitoring is required. The information must include the instrument used, last calibration date and results and, for field measurements, the name of the person who conducted the measurement.

B. Operational Requirements

1. Sample results

Pursuant to California Water Code Section 13267(b), the Discharger shall maintain all sampling and analytical results including: strip charts; date; exact place, and time of sampling; date analyses were performed; sample collector's name; analyst's name; analytical techniques used; and results of all analyses. Such records shall be retained for a minimum of three years. This period of retention shall be extended during the course of any unresolved litigation regarding this discharge, or when requested by the Lahontan Water Board.

2. Operational Log

Pursuant to California Water Code Section 13267(b), an operation and maintenance log shall be maintained at the facility. All monitoring and reporting data shall be recorded in a permanent log book.

PROPOSED

C. Reporting

1. For every item where the requirements are not met, the Discharger shall submit a statement of the actions undertaken or proposed which will bring the discharge into full compliance with requirements at the earliest time, and shall submit a timetable for correction.
2. Pursuant to California Water Code Section 13267(b), all sampling and analytical results shall be made available to the Lahontan Water Board upon request. Results shall be retained for a minimum of three years. This period of retention shall be extended during the course of any unresolved litigation regarding this discharge, or when requested by the Lahontan Water Board.
3. The Discharger shall provide a brief summary of any operational problems and maintenance activities to the Lahontan Water Board with each monitoring report. Any modifications or additions to, or any major maintenance conducted on, or any major problems occurring to the wastewater conveyance system, treatment facilities, or disposal facilities shall be included in this summary.
4. Monitoring reports shall be signed by
 - a. In the case of a corporation, by a principle executive officer at least of the level of vice president or his duly authorized representative, if such representative is responsible for the overall operation of the facility from which the discharge originates.
 - b. In the case of a partnership, by a general partner.
 - c. In the case of a sole proprietorship, by the proprietor; or
 - d. In the case of a municipal, state or other public facility, by either a principle executive officer, ranking elected official, or other duly authorized employee.
5. Monitoring reports are to include the following:
 - a. Name and telephone number of individual who can answer questions about the report.
 - b. The Monitoring and Reporting Program Number.
 - c. WDID Number 6A181554001.
 - d. All monitoring reports submitted to the Lahontan Water Board shall be transmitted using the cover letter form in Attachment I or a cover letter containing the same information and certification as in Attachment I.

D. Noncompliance

Under section 13268 of the Water Code, any person failing or refusing to furnish technical or monitoring reports required pursuant to Water Code section 13267, or falsifying any information provided therein, is guilty of a misdemeanor and may be liable civilly in an amount of up to one thousand dollars (\$1,000) for each day of violation.

II. MONITORING LOCATIONS

The Discharger shall establish the following monitoring locations to demonstrate compliance with the effluent limitations, discharge specifications, and other requirements in this Order:

Table E-1. Monitoring Station Locations

Discharge Point Name	Monitoring Location Name	Monitoring Location Description
--	INF-001	Wastewater influent collected prior to the fine screen in the headworks of the facility
001	EFF-001	Effluent wastewater from the treatment facility, at final discharge from the wetlands to the irrigation channel that is tributary to Jensen Slough (formerly Monitoring Location 03).
--	EFF-002	Wastewater from within the treatment facility, at the point of release from the dechlorination facility (formerly Monitoring Location 03A).
--	RSW-001	Receiving water (Jensen Slough) monitoring location just upstream from where the Jensen Slough crosses Skyline Drive
--	RSW-002	Receiving water monitoring location approximately 50 feet downstream from the confluence of the irrigation channel and the Jensen Slough

III. INFLUENT MONITORING REQUIREMENTS

A. Monitoring Location INF-001

1. Inflow to the treatment works shall be measured at INF-001. The total volume, daily flow and average monthly flow (as MGD) shall be computed, as well as the volumes of daily and monthly diversions to and from the emergency storage ponds, and the amount of wastewater in emergency storage ponds.
2. The influent shall be sampled on the same days that the effluent is sampled during the months of January, April, July, and October (at least four (4) samples per year unless otherwise noted below).
3. The Discharger shall monitor influent to the facility at INF-001 as follows:

Table E-2. Influent Monitoring INF-001

Parameter	Units	Sample Type	Minimum Sampling Frequency	Required Analytical Test Method
Flow	MGD	Continuous	Continuous	Not Applicable
BOD 5-day 20°C	mg/L	24-Hr. Composite	1x/Week	Per Standard Methods
Total Suspended Solids	mg/L	24-Hr. Composite	1x/Week	Per Standard Methods
Total Dissolved Solids	mg/L	24 hr Composite	1x/Week	Per Standard Methods
Copper	mg/L	8-hour Composite	1x/Year	Per Standard Methods
Zinc	mg/L	8-hour Composite	1x/Year	Per Standard Methods

IV. EFFLUENT MONITORING REQUIREMENTS

A. Monitoring Location EFF-001

1. The Discharger shall monitor the wastewater effluent at EFF-001 as follows. If more than one analytical test method is listed for a given parameter, the Discharger must select from the listed methods and corresponding Minimum Level.
2. To the maximum extent practical, effluent samples shall be collected during times when wastewater treatment facilities are under maximum stress due to high flow, high organic loading conditions, etc.
3. Effluent samples for BOD and Total Suspended Solids must be collected after an appropriate residence time from the influent sampling so as to facilitate proper determination of plant removal efficiencies.

PROPOSED

Table E-3. Effluent Monitoring EFF-001

Parameter	Units	Sample Type	Minimum Sampling Frequency	Required Analytical Test Method
Flow	MGD	Continuous	Continuous	Not applicable
Residual Chlorine	mg/L	Grab	1x/Week	Per Standard Methods
BOD 5-day 20°C	mg/L	24-hr composite	1x/Week	Per Standard Methods
Total Suspended Solids	mg/L	24-hr composite	1x/Week	Per Standard Methods
Settleable Solids	mg/L	24-hr composite	1x/Week	Per Standard Methods
pH	Standard Units	Grab	1x/Week	Per Standard Methods
Electrical Conductivity	µmhos/cm	Grab	1x/Week	Per Standard Methods
Turbidity	NTU	Grab	1x/Week	Per Standard Methods
Fecal Coliform	MPN/100mL or MFC/100mL	Grab	1x/Week	Per Standard Methods
Total Coliform	MPN/100ml	Grab	1x/Week	Per Standard Methods
Dissolved Oxygen	mg/L	Grab	1x/Month	Per Standard Methods
Temperature	°C	Grab	1x/Month	Not applicable
Total Dissolved Solids	mg/L	Grab	1x/Month	Per Standard Methods
Chloride	mg/L	Grab	1x/Month	Per Standard Methods
Sulfate	mg/L	24-hr composite	1x/Month	Per Standard Methods
Boron	mg/L	24-hr composite	1x/Month	Per Standard Methods
Total Nitrogen	mg/L as N	24-hr composite	1x/Month	Per Standard Methods
Total Phosphorus	mg/L as P	24-hr composite	1x/Month	Per Standard Methods
Sodium	mg/L	24-hr composite	1x/Month	Per Standard Methods
Calcium	mg/L	24-hr composite	1x/Month	Per Standard Methods
Magesium	mg/l	24-hr composite	1x/Month	Per Standard Methods
Un-ionized Ammonia	mg/L	24-hr composite	1x/Month	Per Standard Methods
Hardness	mg/L as CaCO ₃	24-hr composite	1x/Month	Per Standard Methods
Chronic Toxicity	TU _c	24-hr Composite	2x/Year	Per Standard Methods
Organophosphates, Carbamates, and other Pesticide/Herbicide Groups (EPA 608, 614, and 632)	mg/L	24-hour composite	1x/Year	Per Standard Methods
Trihalomethanes	mg/L	24-hour composite	4x/Year	Per Standard Methods
Priority Pollutants (see attachment G)	µg/L	24-hour composite	1x/Year	Per Standard Methods

B. Monitoring Location EFF-002

1. The Discharger shall monitor wastewater effluent at EFF-002 as follows:

Table E-4. Effluent Monitoring EFF-002

Parameter	Units	Sample Type	Minimum Sampling Frequency	Required Analytical Test Method
Fecal Coliform	MPN/100mL or MFC/100mL	Grab	1x/Month	Per Standard Methods
Total Coliform	MPN/100ml	Grab	1X/Month	Per Standard Methods
Total Dissolved Solids	mg/L	Grab	1x/Quarter	Per Standard Methods
Electrical Conductivity	µmhos/cm	Grab	1x/Month	Per Standard Methods

V. WHOLE EFFLUENT TOXICITY (WET) TESTING REQUIREMENTS

A. Monitoring Requirements

1. The Discharger must conduct chronic and acute toxicity testing on the final effluent discharged at monitoring point EFF-001.

Test	Units	Sample Type	Minimum Sampling Frequency
Chronic Toxicity	TU _c ¹	24-hr Composite	Semi-Annual
Acute Toxicity	TU _a ^{2,3,4}	24 hr composite	Semi-Annual

¹ Chronic toxicity units

² Acute toxicity units

³ Acute Bioassay results can be calculated from chronic bioassay test for *Pimephales promelas*

⁴ Discharger can provide Pass/Fail when using a t-test

2. Toxicity Test References for Conducting Toxicity Tests

- a. Methods for Measuring the Acute Toxicity of Effluents and Receiving Waters to Freshwater and Marine Organisms, Fifth Edition, EPA/821-R-02-012, October 2002 or subsequent editions.
- c. Short Term Methods for Estimating the Chronic Toxicity of Effluents and Receiving Water for Freshwater Organisms, Fourth Edition, EPA/821-R-02-013, October 2002 or subsequent editions.

3. Test species given below shall be used to measure chronic toxicity and if in the case of *Pimephales promelas* the acute toxicity will be calculated:

Species	Effect	Test Duration (days)	Reference
Fathead Minnow (<i>Pimephales promelas</i>)	Larval Survival and Growth	7	EPA/821-R-02-013 (Chronic) EPA/821-R-02-012 ¹ (Acute)
Water Flea (<i>Ceriodaphnia dubia</i>)	Survival and Reproduction	6-8	EPA/821-R-02-013 (Chronic) EPA/821-R-02-012 (Acute)
Alga (<i>Selenastrum Capricornutum</i>)	Growth rate	4	EPA/821-R-02-013 (Chronic) EPA/821-R-02-012 (Acute)

¹ Acute bioassay results can be calculated from chronic bioassay test for *Pimephales promelas*

B. Acute WET Testing – Monitoring Location EFF-001

1. The discharger shall conduct acute WET tests on grab samples of undiluted effluent and an appropriate control water, as specified in the test method, a minimum of twice per calendar year.
2. Acute WET results shall be reported in percent survival.
5. Concurrent testing with reference toxicants shall be conducted using the same test conditions as the effluent toxicity test (i.e., same test duration, etc.).
6. If either the reference toxicant tests or the effluent tests do not meet all test acceptability criteria as specified in the test methods manual, the Discharger must re-sample and re-test within 14 days of receiving the results of the failed test.
7. The Discharger shall submit with the monthly report in which WET test results are due, a full report of acute WET testing that includes: (1) the toxicity test results; (2) the dates of sample collection and initiation of each toxicity test; and (3) the flow rate at the time of sample collection.
8. If survival is less than 90 percent in two consecutive semi-annual WET samples, the discharger shall increase the frequency of acute WET testing to one time per month. When three consecutive monthly tests demonstrate a survival rate of greater than 90 percent of the test organisms, the Discharger may resume acute WET testing at a frequency of twice per calendar year.
9. If any of the accelerated (monthly) tests demonstrate a survival rate of less than 70 percent, the Discharger shall initiate a Toxicity Reduction Evaluation in accordance with the requirements of Section VI.C.2 of the Order

C. Chronic WET Testing – Monitoring Location EFF-001

1. The presence of chronic toxicity shall be determined as specified in USEPA's short-term chronic toxicity test methods in 40 CFR Part 136 for the test listed above Ceriodaphnia dubia survival and reproduction, Pimephales promelas larval survival and growth and Alga Selenastrum capricornutum for growth rate.
2. The discharger shall conduct chronic WET tests on undiluted (100% effluent) grab samples a minimum of twice per calendar year and shall use an appropriate control water, as specified in the test method.
3. Where possible, the Discharger shall perform both chronic WET testing and chemical-specific testing for parameters limited by this Order for which a grab sample is required using a split sample.

4. For routine testing, Analysis of Variance (ANOVA) with $\alpha = 0.05$ shall be used to determine whether differences between control and effluent data are significant.
5. If a chronic toxicity test indicates a statistically significant difference between a sample of 100% effluent and a control, the discharger shall initiate accelerated chronic WET testing at a frequency of one time per month.
6. Accelerated chronic WET results shall be reported in TU_c where:

$$TU_c = \frac{100}{NOEC}$$

NOEC = No Observed Effect Concentration: the highest concentration of effluent to which organisms are exposed in a chronic test that causes no observable adverse effect on the test organisms (e.g., the highest concentration of effluent to which the values for the observed response show no statistically significant difference from a control).

Accelerated chronic WET testing shall use a series of five dilutions and a control. The dilutions shall be 12.5, 25, 50, 75, and 100 percent effluent, along with the control (0 percent effluent). Concurrent testing with reference toxicants shall be conducted using the same test conditions as the effluent toxicity test (i.e., same test duration, etc.).

7. When three consecutive accelerated monthly tests demonstrate no chronic toxicity, which is defined as WET test results not exceeding 1.0 TU_c , the Discharger may resume routine chronic WET testing at a frequency of twice per calendar year.
8. If either the reference toxicant tests or the effluent tests do not meet all test acceptability criteria as specified in the test methods manual, the Discharger must re-sample and re-test within 14 days of receiving the results of the failed test.
9. The Discharger must submit with the monthly report in which WET test results are due, a full report of chronic WET testing that includes: (1) the toxicity test results; (2) the dates of sample collection and initiation of each toxicity test; and (3) the flow rate at the time of sample collection.
10. If any of the accelerated (monthly) tests demonstrate chronic toxicity ($TU_c > 1.0$), the Discharger shall initiate a Toxicity Reduction Evaluation in accordance with the requirements of Section VI.C.2 of the Order.

D. Definition of Toxicity

1. Chronic toxicity measures sublethal effect (e.g., reduced growth, reproduction) to experimental test organisms exposed to an effluent or ambient waters compared to that of the control organisms.

2. Chronic toxicity shall be measured in TU_c , where $TU_c = 100/NOEC$. The no observed effect concentration (NOEC) is the highest concentration of toxicant to which organisms are exposed in a chronic test that causes no observable adverse effect on the test organisms (e.g., the highest concentration of toxicant to which the values for the observed responses are not statistically significantly different from the controls).
3. Acute toxicity is a measure of primarily lethal effects that occur over a ninety-six (96) hour period. Acute toxicity for *Pimephales promelas* can be calculated from the results of the chronic toxicity test for *Pimephales promelas* and reported along with the results of each chronic test. Acute toxicity for *Ceriodaphnia dubia* cannot be calculated from the results of the chronic toxicity test for *Ceriodaphnia dubia* because the test design is not amenable to calculation of a lethal concentration (LC50) value as needed for the acute requirement.
4. Acute toxicity shall be measured in Tu_a , where $Tu_a = 100/LC50$ or as pass/fail using a t-test. LC50 is the toxicant concentration that would cause death in 50 percent of the test organisms.

E. Reporting

1. The Discharger must submit with the discharge monitoring reports for the month in which the last test is conducted the analysis and results of the toxicity test, including any accelerated testing, in toxicity units.
2. If a TIE is conducted the Discharger shall submit the results of the TIE with the discharge monitoring reports for the month in which the final report is completed.
3. If the TRE Workplan has been initiated, the Discharger shall report on the progress of the actions being taken and include this information with each monthly monitoring report.

VI. LAND DISCHARGE MONITORING REQUIREMENTS – NOT APPLICABLE

VII. RECLAMATION MONITORING REQUIREMENTS – NOT APPLICABLE

VIII. RECEIVING WATER MONITORING REQUIREMENTS – SURFACE WATER

A. Monitoring Location RSW-001

The Discharger must monitor RSW-001 for the following constituents listed in Table E-5a: However, if there is no flow at this location, no samples are required provided the no flow condition is noted.

Table E-5a. Receiving Water Monitoring Requirements RSW-001

Parameter	Units	Sample Type	Minimum Sampling Frequency	Required Analytical Test Method
Flow	MGD	Field Measurement	1x/Month	Not Applicable
pH	Standard Units	Grab	1x/Month	Per Standard Methods
Electrical Conductivity	µmhos/cm	Grab	1x/Month	Per Standard Methods
Turbidity	NTU	Grab	1x/Month	Per Standard Methods
Dissolved Oxygen	mg/L	Grab	1x/Month	Per Standard Methods
Temperature	°C	Grab	1x/Month	Per Standard Methods
Total Dissolved Solids	mg/L	Grab	1x/Month	Per Standard Methods
Chloride	mg/L	Grab	1x/Month	Per Standard Methods
Sulfate	mg/L	Grab	1x/Month	Per Standard Methods
Boron	mg/L	Grab	1x/Month	Per Standard Methods
Total Nitrogen	mg/L as N	Grab	1x/Month	Per Standard Methods
Total Phosphorus	mg/L as P	Grab	1x/Month	Per Standard Methods
Sodium	mg/L	Grab	1x/Month	Per Standard Methods
Calcium	mg/L	Grab	1x/Month	Per Standard Methods
Magnesium	mg/L	Grab	1x/Month	Per Standard Methods
Un-ionized Ammonia	mg/L	Grab	1x/Month	Per Standard Methods
Hardness	mg/L as CaCO ₃	Grab	1x/Month	Per Standard Methods
Organophosphates, Carbamates, and other Pesticide/Herbicide Groups (EPA 608, 614, and 632)	mg/L	Grab	1x/Year	Per Standard Methods
Priority Pollutants (see Attachment G)	µg/L	Grab	1x/Year	Per Standard Methods

B. Monitoring Location RSW-002

The Discharger shall monitor the receiving water approximately 50 feet downstream from the confluence of the irrigation channel and the Jensen Slough.

Table E-5b. Receiving Water Monitoring Requirements RSW-002

Parameter	Units	Sample Type	Minimum Sampling Frequency	Required Analytical Test Method
Flow	MGD	Measurement	1/Month	Not Applicable
pH	Standard Units	Grab	1x/Month	Per Standard Methods
Electrical Conductivity	µmhos/cm	Grab	1x/Month	Per Standard Methods
Total Dissolved Solids	mg/L	Grab	1x/Month	Per Standard Methods
Chloride	mg/L	Grab	1x/Month	Pre Standard Methods
Sulfate	mg/L	Grab	1x/Month	Per Standard Methods
Boron	mg/L	Grab	1x/Month	Per Standard Methods
Total Nitrogen	mg/L as N	Grab	1x/Month	Per Standard Methods
Total Phosphorus	mg/L as P	Grab	1x/Month	Per Standard Methods
Sodium	mg/L	Grab	1x/Month	Per Standard Methods
Calcium	mg/L	Grab	1x/Month	Per Standard Methods
Magnesium	mg/L	Grab	1x/Month	Per Standard Methods
Hardness	mg/L as CaCO ₃	Grab	1x/Month	Per Standard Methods
Un-ionized Ammonia	mg/L	Grab	1x/Month	Per Standard Methods

C. Visual Monitoring at RSW-001 and RSW-002

1. In conducting the receiving water sampling, a log shall be kept of the receiving water conditions at Monitoring Locations RSW-001 and RSW-002. In the event that no water is present or is frozen, notes on receiving water conditions must be maintained in the log and transmitted in the monitoring reports provided to the Lahontan Water Board. Attention shall be given to observing and describing the presence or absence of:
 - a. Floating or suspended matter;
 - b. Discoloration;
 - c. Aquatic life (including plants, fish, shellfish, birds);
 - d. Visible film, sheen, or coating;
 - e. Fungi, slime, or objectionable growths; and
 - f. Potential nuisance conditions (unusual or objectionable conditions).

IX. OTHER MONITORING REQUIREMENTS

A. Monitoring Location SLD-001 Sludge Monitoring

1. The Discharge must submit the total quantity of sludge generated and disposed of during the monitoring period.

2. Date and quantity of any sludge landfilled or moved offsite, recipient (including name and address), location of receiving area, and sludge disposal method (including crops grown, if applicable).
3. Cumulative total quantity of sludge stored onsite or the storage capacity in use to hold the sludge prior to disposal.

X. REPORTING REQUIREMENTS

A. General Monitoring and Reporting Requirements

The Discharger shall comply with all Standard Provisions (Attachment D) related to monitoring, reporting, and recordkeeping.

B. Self Monitoring Reports (SMRs)

1. At any time during the term of this permit, the State or Lahontan Water Board may notify the Discharger to electronically submit Self-Monitoring Reports (SMRs) using the State Water Board's California Integrated Water Quality System (CIWQS) Program Web site (<http://www.waterboards.ca.gov/ciwqs/index.html>). Until such notification is given, the Discharger shall submit hard copy SMRs. The CIWQS Web site will provide additional directions for SMR submittal in the event there will be service interruption for electronic submittal.
2. The Discharger shall report in the SMR the results for all monitoring specified in this MRP under sections III through IX. The Discharger shall submit SMRs monthly, quarterly, and annual including the results of all required monitoring using USEPA-approved test methods or other test methods specified in this Order. If the Discharger monitors any pollutant more frequently than required by this Order, the results of this monitoring shall be included in the calculations and reporting of the data submitted in the SMR.
3. Monitoring periods and reporting for all required monitoring shall be completed according to the following schedule:

Table E-6. Monitoring Periods and Reporting Schedule

Sampling Frequency	Monitoring Period Begins On...	Monitoring Period	SMR Due Date
Continuous	Permit effective date	All	Within 15 days after the end of the month
Daily	Permit effective date	(Midnight through 11:59 PM) or any 24-hour period that reasonably represents a calendar day for purposes of sampling.	Within 15 days after the end of the month
Weekly	Sunday following permit effective date or on permit effective date if on a Sunday	Sunday through Saturday	Within 15 days after the end of the month
Monthly	First day of calendar month following permit effective date or on permit effective date if that date is first day of the month	1 st day of calendar month through last day of calendar month	Within 15 days after the end of the month
Quarterly	Closest of January 1, April 1, July 1, or October 1 following (or on) permit effective date	- January 1 through March 31 - April 1 through June 30 - July 1 through September 30 - October 1 through December 31	Within 15 days after the end of the monitoring period.
Semi Annually	Closest of January 1 and July 1 following (or on) the permit effective date	- January 1 through June 30 - July 1 through December 31	Within 15 days after the end of the monitoring period.
Annually	January 1 following (or on) permit effective date	January 1 through December 31	Within 15 days from the end of the monitoring period.

4. Reporting Protocols. The Discharger shall report with each sample result the applicable Reporting Level (RL) and the current Method Detection Limit (MDL), as determined by the procedure in Part 136.

The Discharger shall report the results of analytical determinations for the presence of chemical constituents in a sample using the following reporting protocols:

- a. Sample results greater than or equal to the RL shall be reported as measured by the laboratory (i.e., the measured chemical concentration in the sample).
- b. Sample results less than the RL, but greater than or equal to the laboratory's MDL, shall be reported as "Detected, but Not Quantified," or DNQ. The estimated chemical concentration of the sample shall also be reported.

For the purposes of data collection, the laboratory shall write the estimated chemical concentration next to DNQ as well as the words "Estimated Concentration" (may be shortened to "Est. Conc."). The laboratory may, if such information is available, include numerical estimates of the data quality for the reported result. Numerical estimates of data quality may be percent accuracy (\pm a percentage of the reported value), numerical ranges (low to high), or any other means considered appropriate by the laboratory.

- c. Sample results less than the laboratory's MDL shall be reported as "Not Detected," or ND.

- d. Dischargers are to instruct laboratories to establish calibration standards so that the ML value (or its equivalent if there is differential treatment of samples relative to calibration standards) is the lowest calibration standard. At no time is the Discharger to use analytical data derived from *extrapolation* beyond the lowest point of the calibration curve.
5. The Discharger shall submit SMRs in accordance with the following requirements:
- a. The Discharger shall arrange all reported data in a tabular format. The data shall be summarized to clearly illustrate whether the facility is operating in compliance with interim and/or final effluent limitations. The Discharger is not required to duplicate the submittal of data that is entered in a tabular format within CIWQS. When electronic submittal of data is required and CIWQS does not provide for entry into a tabular format within the system, the Discharger shall electronically submit the data in a tabular format as an attachment.
 - b. The Discharger shall attach a cover letter to the SMR. The information contained in the cover letter shall clearly identify violations of the WDRs; discuss corrective actions taken or planned; and the proposed time schedule for corrective actions. Identified violations must include a description of the requirement that was violated and a description of the violation.
 - c. SMRs must be submitted to the Lahontan Water Board, signed and certified as required by the Standard Provisions (Attachment D), to the address listed below:

California Regional Water Quality Control Board, Lahontan Region
2501 Lake Tahoe Boulevard
South Lake Tahoe, CA 96150

C. Discharge Monitoring Reports (DMRs)

1. As described in Section X.B.1 above, at any time during the term of this permit, the State or Lahontan Water Board may notify the Discharger to electronically submit SMRs that will satisfy federal requirements for submittal of Discharge Monitoring Reports (DMRs). Until such notification is given, the Discharger shall submit DMRs in accordance with the requirements described below.
2. DMRs must be signed and certified as required by the standard provisions (Attachment D). The Discharge shall submit the original DMR and one copy of the DMR to the address listed below:

Standard Mail	FedEx/UPS/ Other Private Carriers
State Water Resources Control Board Division of Water Quality c/o DMR Processing Center PO Box 100 Sacramento, CA 95812-1000	State Water Resources Control Board Division of Water Quality c/o DMR Processing Center 1001 I Street, 15 th Floor Sacramento, CA 95814

- All discharge monitoring results must be reported on the official USEPA pre-printed DMR forms (EPA Form 3320-1). Forms that are self-generated or modified cannot be accepted.

D. Other Reports

- The Discharger shall report the results of any special studies, compliance reports, acute and chronic toxicity testing, TRE/TIE, and Pollution Prevention Plan required under the Special Provisions – VI.C of this Order. The Discharger shall submit reports with the first monthly SMR scheduled to be submitted on or immediately following the report due date, or February 1 for annual reports, in compliance with SMR reporting requirements described in subsection X.B.6 above.
- Operations and Maintenance Report

The Discharger shall report the following:

Activity	Reporting Frequency
Results of routine inspections of each unit process.	1x/Month
Broken or malfunctioning equipment or unit processes. Associated repair or replacement activity.	1x/Month
Calibration of flow meters and mechanical equipment shall be performed in a timely manner and documented in accordance with the manufacturer recommendations.	1x/Year

ATTACHMENT F

06-0066

ATTACHMENT F – FACT SHEET

Table of Contents

Attachment F – Fact Sheet F-3

I. Permit Information..... F-3

 A. Description of Wastewater and Biosolids Treatment or Controls..... F-4

 B. Discharge Points and Receiving Waters..... F-5

 C. Summary of Existing Requirements and Self-Monitoring Report (SMR) Data..... F-5

 D. Compliance Summary F-6

 E. Planned Changes F-7

III. Applicable Plans, Policies, and Regulations F-7

 A. Legal Authorities..... F-7

 B. California Environmental Quality Act (CEQA)..... F-7

 C. State and Federal Regulations, Policies, and Plans..... F-7

 D. Impaired Water Bodies on CWA 303(d) List..... F-9

 E. Other Plans, Policies and Regulations – Not Applicable..... F-10

IV. Rationale For Effluent Limitations and Discharge Specifications..... F-10

 A. Discharge Prohibitions..... F-10

 B. Technology-Based Effluent Limitations..... F-11

 1. Scope and Authority F-11

 2. Applicable Technology-Based Effluent Limitations..... F-11

 C. Water Quality-Based Effluent Limitations (WQBELs)..... F-13

 1. Scope and Authority F-13

 2. Applicable Beneficial Uses and Water Quality Criteria and Objectives..... F-13

 3. Determining the Need for WQBELs..... F-15

 4. WQBEL Calculations F-17

 5. WQBELs Based on Basin Plan Objectives..... F-17

 6. WQBELs Based on Title 22 "California Health Laws . . . to Recycled Water" F-17

 7. WQBELs Based on State Water Board Policy..... F-18

 8. Whole Effluent Toxicity (WET)..... F-18

 D. Final Effluent Limitations..... F-19

 E. Interim Effluent Limitations – Not Applicable..... F-21

 F. Land Discharge Specifications – Not Applicable..... F-21

 G. Reclamation Specifications – Not Applicable..... F-22

V. Rationale for Receiving Water Limitations F-22

 A. Surface Water..... F-22

 B. Groundwater..... F-24

VI. Rationale for Monitoring and Reporting Requirements F-24

 A. Influent Monitoring F-24

 B. Effluent Monitoring..... F-24

 C. Whole Effluent Toxicity Testing Requirements F-25

 D. Receiving Water Monitoring..... F-25

 1. Surface Water F-25

 2. Groundwater – Not Applicable..... F-25

 E. Other Monitoring Requirements..... F-26

 1. Biosolids/Sludge Monitoring F-26

VII. Rationale for Provisions F-26

 A. Standard Provisions..... F-26

B. Special Provisions	F-26
1. Reopener Provisions	F-26
2. Special Studies and Additional Monitoring Requirements	F-26
3. Best Management Practices and Pollution Prevention	F-27
4. Construction, Operation, and Maintenance Specifications	F-27
5. Special Provisions for Municipal Facilities (POTWs Only)	F-27
6. Other Special Provisions – Not Applicable	F-27
7. Compliance Schedules – Not Applicable	F-27
VIII. Public Participation	F-27
A. Notification of Interested Parties	F-27
B. Written Comments	F-27
C. Public Hearing	F-28
D. Waste Discharge Requirements Petitions	F-28
E. Information and Copying	F-28
F. Register of Interested Persons	F-28
G. Additional Information	F-28

List of Tables

Table F-1. Facility Information	F-3
Table F-2. Historic Effluent Limitations and Monitoring Data	F-6
Table F-3a. Surface Water Basin Plan Beneficial Uses	F-8
Table F-3b. Ground Water Basin Plan Beneficial Uses	F-8
Table F-4. Summary of Technology-based Effluent Limitations	F-12
Table F-5. Basis for Limitations	F-12
Table F-6. Comparison of Water Quality Objectives vs Effluent	F-14
Table F-7. Applicable Water Quality Criteria	F-15
Table F-8. Summary Reasonable Potential Analysis	F-17
Table F-9. Summary of Water Quality-based Effluent Limitations	F-18
Table F-10. Summary of Final Effluent Limitations	F-21
Table F-11. Receiving Water Limitations	F-22

ATTACHMENT F – FACT SHEET

As described in section II of this Order, this Fact Sheet includes the legal requirements and technical rationale that serve as the basis for the requirements of this Order.

This Order has been prepared under a standardized format to accommodate a broad range of discharge requirements for Dischargers in California. Only those sections or subsections of this Order that are specifically identified as “not applicable” have been determined not to apply to this Discharger. Sections or subsections of this Order not specifically identified as “not applicable” are fully applicable to this Discharger.

I. PERMIT INFORMATION

The following table summarizes administrative information related to the facility.

Table F-1. Facility Information

WDID	6A181554001
Discharger	Susanville Sanitary District
Name of Facility	Wastewater Treatment Plant, Susanville
Facility Address	476-200 Bunyan Road
	Susanville, CA 96130
	Lassen County
Facility Contact, Title and Phone	Randy O’Hern, General Manager, (530) 257 – 5665
Authorized Person to Sign and Submit Reports	Randy O’Hern, General Manager, (530) 257 - 5665
Mailing Address	45 S. Roop Street P.O. Box 152 Susanville, CA 96130
Billing Address	SAME AS MAILING ADDRESS
Type of Facility	POTW
Major or Minor Facility	Major
Threat to Water Quality	1
Complexity	A
Pretreatment Program	No
Reclamation Requirements	N/A
Facility Permitted Flow	2.0 MGD
Facility Design Flow	2.0 MGD
Watershed	Susan River Hydrologic Area
Receiving Water	Jensen Slough
Receiving Water Type	Inland Surface Water

- A.** Susanville Sanitary District (hereinafter Discharger) is the owner and operator of the Susanville Treatment Plant (hereinafter Facility), a wastewater treatment plant. For the purposes of this Order, references to the “discharger” or “permittee” in applicable federal and state laws, regulations, plans, or policy are held to be equivalent to references to the Discharger herein.

- B.** The Discharger discharges secondary treated disinfected wastewater to an unlined constructed irrigation channel. The effluent is used during the growing season to irrigate ranches and/or finally reaches the Jensen Slough which is a tributary of the Susan River. Both the Jensen Slough and the Susan River are waters of the United States. The discharge is currently regulated by Order No. R6T-2002-0031 which was adopted on May 8, 2002 and expired on May 8, 2007. The terms and conditions of the current Order have been administratively continued and remain in effect until new Waste Discharge Requirements and NPDES permit are adopted pursuant to this Order.

The Discharger filed a report of waste discharge and submitted an application for renewal of its Waste Discharge Requirements (WDRs) and National Pollutant Discharge Elimination System (NPDES) permit on November 7, 2006. Supplemental information was requested on March 23, 2007 and received on March 23, 2007. Site visits were conducted on June 25, 2007 and on April 1, 2008, to observe operations and collect additional data to develop permit limitations and conditions.

II. Facility Description

A. Description of Wastewater and Biosolids Treatment or Controls

The existing Facility provides for secondary wastewater treatment that consists of: screening, grit removal, extended aeration (oxidation ditches), activated sludge processing, secondary clarification, disinfection (chlorine), de-chlorination processes (box and open ponds) and a wetland complex where the treated effluent resides prior to discharge via outfall EFF-001.

The influent flows into the headworks, which consist of fine screening and a grit chamber. Then the wastewater flows to a distribution box that can convey the wastewater to the emergency storage ponds (see below) or to the two oxidation ditches for treatment. The two oxidation ditches are designed to be able to be run in parallel and may be operated in series. The wastewater is passed through a secondary clarifier and a chlorine disinfection process. From the disinfection process, the wastewater may be discharged into the emergency storage ponds or continue in an underground pipe (that acts as a chlorine contact chamber) and discharge into a dechlorination box and an open pond to remove the chlorine. From the open pond the treated effluent passes through a polishing wetland prior to being discharged into an unlined channel (EFF-001). The effluent is used to irrigate rangelands and finally discharges into Jensen Slough.

There are two emergency storage ponds, No. 1 and No. 2. The emergency storage ponds are unlined, cover approximately 8.2 acres, and are some four feet deep providing an estimated 10.7 million gallons of storage if needed. The ponds have the ability to receive effluent from the headworks and/or from the disinfection process. The raw or partially treated wastewater flows by gravity to a lift station that pumps the wastewater back into the headworks screening process. These ponds are used during emergencies, high flow, power outages, maintenance and system failures.

Sludge handling and treatment systems at the Facility include an aerobic digester, sludge storage tank and a centrifuge to dewater the sludge. Chemical analyses of the sludge indicate that concentrations of toxic constituents are below hazardous waste limits

specified in Title 26 of the California Code of Regulations. Sludge is dewatered by centrifuge and relinquished to others for application to agricultural lands in Lassen County. Dewatered sludge is also transported to a landfill in Nevada.

The Facility is currently capable of treating, and disposing an annual average flow of 2.0 MGD of municipal wastewater with current flows averaging approximately 1.12 MGD. There is a maximum average annual flow of 1.486 MGD, a peak wet weather design flow of 3.1 MGD, and a maximum hydraulic capacity of 4.0 MGD.

B. Discharge Points and Receiving Waters

Chlorinated wastewater effluent is dechlorinated by aeration in a dechlorination box and finishes dechlorination in open storage ponds. Dechlorinated effluent flows through a constructed polishing wetland prior to being discharged to a constructed discharge channel (irrigation channel) traversing adjacent agricultural lands.

The water from this irrigation channel is used by others (not the Discharger) for irrigation (during the growing season), and livestock watering. Unused water in the irrigation channel and applied tailwater flows into the Jensen Slough and is used on other agricultural lands. The Jensen Slough receives water from a diversion on the Susan River, and is a tributary to the Susan River. The wastewater effluent, water from the irrigation channel and slough system, and agricultural return flows eventually discharge into the Susan River as shown on Attachment B (Effluent Discharge Location Map), which is made part of this Order.

The discharge point for the effluent to the constructed irrigation channel is Discharge point EFF-001 and is located at latitude 40° 24' 50" N and longitude 120° 37' 0" W.

C. Summary of Existing Requirements and Self-Monitoring Report (SMR) Data

1. Flow Limitations

The average rate of effluent flow from the facility in any one-month period shall not be more than 2.0 MGD.

2. Effluent Limitations

Effluent limitations contained in the existing Order for discharges from Discharge Point EFF-001 and representative monitoring data from the term of the previous Order are as follows:

Table F-2. Historic Effluent Limitations and Monitoring Data

Parameter	Units	Effluent Limitation			Monitoring Data (From December 2000 – To January 2007)		
		Average Monthly	Average Weekly	Maximum Daily	Highest Average Monthly Discharge	Highest Average Weekly Discharge	Highest Daily Discharge
Biological Oxygen Demand	mg/L	30	45	---	21	32	32
Suspended Solids	mg/L	30	45	---	37	48	48
pH	Standard Units	---	---	6.5 – 8.5	---	---	7 – 8.36 ¹
Removal Efficiency for BOD	%	85	---	---	92 ²	---	---
Removal Efficiency for TSS	%	85	---	---	84 ²	---	---
Total Coliform	MPN	23	23	240	---	---	---

¹ This represents the range of reported pH values in the effluent.

² This value represents the lowest reported removal efficiency for BOD and TSS. The limitation for removal efficiency for TSS was violated once (June 2001), at 84%.

D. Compliance Summary

In April 2004, Lahontan Water Board Staff conducted a Facility compliance inspection and identified that fecal coliform in effluent taken at discharge from the wetland (the then-designated point of compliance) exceeded the effluent limit. It was noted that coliform levels immediately after chlorination meet the limit, but it was considered that the wildlife activity in the open pond and wetland reintroduce coliform, as the wildlife activity is substantial.

Beginning in March 2004, the Discharger began submitting effluent fecal coliform data that was collected at the chlorine contact chamber in addition to what was collected from the discharge point from the wetland to the irrigation channel. The samples collected from the chlorine contact chamber's discharge were consistently in compliance with the Discharger's permit limits, while the majority of the samples collected from the discharge from the wetland were not in compliance. This indicates that the wildlife in the wetland reintroduce coliform into the wastewater. As a result, the point of compliance for fecal coliform will be moved from EFF-001 to EFF-002.

In February 2005, turbidity exceeded the existing effluent limit. The water level was increased in the wetland to reduce turbidity. The Discharger provided turbidity data that showed a decrease in turbidity after corrective action was taken.

E. Planned Changes

The Discharger will be discharging wastewater into emergency storage ponds, including discharging vacuum truck waste collected from spills and collection system maintenance, and discharges from the wastewater treatment system for routine maintenance activities within the treatment plant.

During the upcoming permit term, the Discharger is considering changing disinfection systems, from operating a liquid chlorine system to an ultraviolet (UV) system.

III. APPLICABLE PLANS, POLICIES, AND REGULATIONS

The requirements contained in the proposed Order are based on the requirements and authorities described in this section.

A. Legal Authorities

This Order is issued pursuant to section 402 of the federal Clean Water Act (CWA) and implementing regulations adopted by the U.S. Environmental Protection Agency (USEPA) and chapter 5.5, division 7 of the California Water Code (commencing with section 13370). It shall serve as a NPDES permit for point source discharges from this facility to surface waters. This Order also serves as Waste Discharge Requirements (WDRs) pursuant to article 4, chapter 4, division 7 of the Water Code (commencing with section 13260).

B. California Environmental Quality Act (CEQA)

Under Water Code section 13389, this action to adopt an NPDES permit is exempt from the provisions of CEQA, Public Resources Code sections 21100 through 21177.

C. State and Federal Regulations, Policies, and Plans

- 1. Water Quality Control Plans.** The California Regional Water Quality Control Board, Lahontan Region (Lahontan Water Board) adopted a Water Quality Control Plan for the Lahontan Region, Basin (hereinafter Basin Plan) on March 31, 1995 that designates beneficial uses, establishes water quality objectives, and contains implementation programs and policies to achieve those objectives for all waters addressed through the plan. Requirements of this Order implement the Basin Plan.

The Basin Plan on page 2-3 states that the beneficial uses of any specifically identified water body generally apply to its tributary streams. The Basin Plan does not specifically identify beneficial uses for the Jensen Slough, but does identify present and potential uses for the Susan River, to which the Jensen Slough is tributary. In addition, the Basin Plan implements State Water Resources Control Board (State Water Board) Resolution No. 88-63, which established State policy that all waters, with certain exceptions, should be considered suitable or potentially suitable for municipal or domestic supply. Thus, beneficial uses for the receiving water for the discharge are as follows:

Table F-3a. Surface Water Basin Plan Beneficial Uses

Discharge Point	Receiving Water Name	Beneficial Use(s)
001	Jensen Slough (and Susan River)	Municipal and domestic water supply (MUN); Agricultural supply (AGR); Industrial supply (IND); Ground water recharge (GWR); Freshwater replenishment (FRSH); Navigation (NAV); contact (REC-1) and non-contact (REC-2) water recreation; Commercial and sport fishing (COMM); Warm freshwater habitat (WARM); Cold freshwater habitat (COLD); Wildlife habitat (WILD); Migration of aquatic organisms (MIGR); Spawning, reproduction and development (SPWN).

The Basin Plan on page 4.6.1 also identifies beneficial uses of ground water that are applicable to all subsurface waters in the Lahontan Region. Beneficial uses of specific ground water basins in the Lahontan Region are designated in Table 2-2 of the Basin Plan. The facility is located within the Honey Lake Ground Water Basin. Unless otherwise designated by the Lahontan Water Board, all ground waters are considered suitable, or potentially suitable, for municipal or domestic water supply (MUN).

Table F-3b. Ground Water Basin Plan Beneficial Uses

Basin Name	Beneficial Use(s)
Honey Lake Ground Water Basin	Municipal and domestic water supply (MUN); Agricultural supply (AGR); Industrial supply (IND); Freshwater replenishment (FRSH); Wildlife habitat (WILD).

2. **National Toxics Rule (NTR) and California Toxics Rule (CTR).** USEPA adopted the NTR on December 22, 1992, and later amended it on May 4, 1995 and November 9, 1999. On May 18, 2000, USEPA adopted the CTR. The CTR promulgated new toxics criteria for California and, in addition, incorporated the previously adopted NTR criteria that were applicable in the state. The CTR was amended on February 13, 2001. These rules contain water quality criteria for priority pollutants.

3. **State Implementation Policy.** On March 2, 2000, the State Water Board adopted the *Policy for Implementation of Toxics Standards for Inland Surface Waters, Enclosed Bays, and Estuaries of California* (State Implementation Policy or SIP). The SIP became effective on April 28, 2000 with respect to the priority pollutant criteria promulgated for California by the USEPA through the NTR and to the priority pollutant objectives established by the Lahontan Water Board in the Basin Plan. The SIP became effective on May 18, 2000 with respect to the priority pollutant criteria promulgated by the USEPA through the CTR. The State Water Board adopted amendments to the SIP on February 24, 2005 that became effective on July 13, 2005. The SIP establishes implementation provisions for priority pollutant criteria and objectives and provisions for chronic toxicity control. Requirements of this Order implement the SIP.

5. **Alaska Rule.** On March 30, 2000, USEPA revised its regulation that specifies when new and revised state and tribal water quality standards (WQS) become effective for CWA purposes (40 C.F.R. § 131.21, 65 Fed. Reg. 24641 (April 27, 2000)). Under

the revised regulation (also known as the Alaska rule), new and revised standards submitted to USEPA after May 30, 2000, must be approved by USEPA before being used for CWA purposes. The final rule also provides that standards already in effect and submitted to USEPA by May 30, 2000, may be used for CWA purposes, whether or not approved by USEPA.

- 6. Antidegradation Policy.** Section 131.12 requires that the state water quality standards include an antidegradation policy consistent with the federal policy. The State Water Board established California's antidegradation policy in State Water Board Resolution No. 68-16. Resolution No. 68-16 incorporates the federal antidegradation policy where the federal policy applies under federal law. Resolution No. 68-16 requires that existing water quality be maintained unless degradation is justified based on specific findings. The Lahontan Water Board's Basin Plan implements, and incorporates by reference, both the State and federal antidegradation policies. The permitted discharge must be consistent with the antidegradation provision of section 131.12 and State Water Board Resolution No. 68-16.
- 7. Anti-Backsliding Requirements.** Sections 402(o)(2) and 303(d)(4) of the CWA and federal regulations at title 40, Code of Federal Regulations section 122.44(l) prohibit backsliding in NPDES permits. These anti-backsliding provisions require that effluent limitations in a reissued permit must be as stringent as those in the previous permit, with some exceptions in which limitations may be relaxed.

D. Impaired Water Bodies on CWA 303(d) List

Section 303(d) of the CWA requires states to identify specific water bodies where water quality standards are not expected to be met after implementation of technology-based effluent limitations on point sources. For all 303(d)-listed water bodies and pollutants, the Lahontan Water Board plans to develop and adopt total maximum daily loads (TMDL) that will specify Waste Load Allocation (WLA) for point sources, and load allocations (LAs) for non-point sources, as appropriate.

On June 28, 2007 USEPA gave final approval to California's 2006 section 303(d) List of Water Quality Limited Segments. The Susan River is listed as an impaired water body for toxicity pursuant to Section 303(d) of the CWA. US EPA testing in 1990 on the Susan River identified toxicity to larval fish and the aquatic plant, duckweed. The cause(s) of toxicity were not identified.

The Susan River was placed on the federal Clean Water Act, Section 303(d) list of impaired water bodies for unknown toxicity. While the toxicity observed in the Susan River samples is a violation of the Lahontan Water Board's Basin Plan narrative water quality objective for toxicity, potential impacts of the toxicity results on biological communities in the Susan River is incompletely known. The Susan River will continue to be 303(d)-listed for "unknown toxicity," but a TMDL is not currently recommended as the appropriate regulatory response since the pollutant(s) causing toxicity has not been decisively identified.

This order includes water quality objectives for toxicity and requires annual whole-effluent toxicity testing. This testing is to ensure discharges do not cause or contribute to toxic conditions in the receiving waters.

E. Other Plans, Policies and Regulations – Not Applicable

IV. RATIONALE FOR EFFLUENT LIMITATIONS AND DISCHARGE SPECIFICATIONS

The CWA requires point source dischargers to control the amount of conventional, non-conventional, and toxic pollutants that are discharged into the waters of the United States. The control of pollutants discharged is established through effluent limitations and other requirements in NPDES permits. There are two principal bases for effluent limitations in the Code of Federal Regulations: section 122.44(a) requires that permits include applicable technology-based limitations and standards; and section 122.44(d) requires that permits include water quality-based effluent limitations to attain and maintain applicable numeric and narrative water quality criteria to protect the beneficial uses of the receiving water.

Effluent limitations for Discharge Point 001 in the previous Order were established for biological oxygen demand, suspended solids, pH, and total coliform; thus effluent limitations for these parameters have been established in this Order. The existing permit established numeric receiving water limitations for total dissolved solids, chloride, total nitrogen, total phosphorus, sulfate, un-ionized ammonia, and boron in addition to numerous narrative limitations for a number of pollutants for the further protection of water quality based upon requirements in the Basin Plan. These requirements have been carried over into this Order. Compliance determination for the coliform limitation will be evaluated at EFF-002 as discussed in section II.D. Compliance Summary.

Generally, mass-based effluent limitations ensure that proper treatment, and not dilution, is employed to comply with the final effluent concentration limitations. Section 122.45(f)(1) requires that all permit limitations, standards or prohibitions be expressed in terms of mass units except under the following conditions: (1) for pH, temperature, radiation or other pollutants that cannot appropriately be expressed by mass limitations; (2) when applicable standards or limitations are expressed in terms of other units of measure; or (3) if in establishing technology-based permit limitation on a case-by-case basis limitation based on mass are infeasible because the mass or pollutant cannot be related to a measure of production. The limitations, however, must ensure that dilution will not be used as a substitute for treatment.

A. Discharge Prohibitions

The discharge prohibitions are based on the requirements of the Basin Plan, State Water Board plans and policies, the California Water Code, and previous permit provisions, and are consistent with the requirements set for other discharges in the Lahontan Region.

B. Technology-Based Effluent Limitations

1. Scope and Authority

Section 301(b) of the CWA and implementing USEPA permit regulations at section 122.44, title 40 of the Code of Federal Regulations, require that permits include conditions meeting applicable technology-based requirements at a minimum, and any more stringent effluent limitations necessary to meet applicable water quality standards. The discharge authorized by this Order must meet minimum federal technology-based requirements based on Secondary Treatment Standards at Part 133 and Best Professional Judgment (BPJ) in accordance with Part 125, section 125.3.

Regulations promulgated in section 125.3(a)(1) require technology-based effluent limitations for municipal Dischargers to be placed in NPDES permits based on Secondary Treatment Standards or Equivalent to Secondary Treatment Standards.

The Federal Water Pollution Control Act Amendments of 1972 (PL 92-500) established the minimum performance requirements for POTWs [defined in section 304(d)(1)]. Section 301(b)(1)(B) of that Act requires that such treatment works must, as a minimum, meet effluent limitations based on secondary treatment as defined by the USEPA Administrator.

Based on this statutory requirement, USEPA developed secondary treatment regulations, which are specified in Part 133. These technology-based regulations apply to all municipal wastewater treatment plants and identify the minimum level of effluent quality attainable by secondary treatment in terms of biochemical oxygen demand (BOD₅), total suspended solids (TSS), and pH.

2. Applicable Technology-Based Effluent Limitations

As required by Section 301(b)(1)(B) of the CWA, the U.S. EPA developed wastewater treatment standards for POTWs to identify the minimum level of effluent quality attainable by secondary treatment. These technology-based effluent limitations establish a treatment performance level in terms of Biochemical Oxygen Demand (BOD₅), suspended solids, and pH. As described in 40 CFR Part 133, secondary treatment shall achieve the following effluent standards:

- a. BOD and Suspended Solids
 - i. The 30-day average shall not exceed 30 mg/l.
 - ii. The 7-day average shall not exceed 45 mg/l.
 - iii. The 30-day average percent removal shall not be less than 85 percent.

- b. The pH shall be maintained within the limits of 6.0 to 9.0.

The technology-based effluent limitations for the discharge from the treatment system through Discharge Point No. 001 at Monitoring Location EFF-001 are summarized in Table F-4:

Summary of Technology-based Effluent Limitations Discharge Point 001

Table F-4. Summary of Technology-based Effluent Limitations

Parameter	Units	Effluent Limitations				
		Average Monthly	Average Weekly	Maximum Daily	Instantaneous Minimum	Instantaneous Maximum
Daily Effluent Flow	MGD	2.0	---	---	---	---
Biochemical Oxygen Demand (BOD) (5-day @ 20 Deg. C)	mg/L	30	45	---	---	---
	lbs/day ¹	500	751	---	---	---
Total Suspended Solids (TSS)	mg/L	30	45	---	---	---
	lbs/day ¹	500	751	---	---	---
pH	pH units	---	---	---	6.0	9.0
30-day Removal Efficiency for BOD and TSS	%	85	---	---	---	---

“---” No effluent limitation is applicable.

¹ The mass-based effluent limitations are based on a design capacity of 2.0 MGD.

c. Basis for Limitations

This facility meets the technology-based regulations for the minimum level of effluent quality attainable by secondary treatment in terms of biochemical oxygen demand (BOD5), TSS, and pH as summarized in Table F-4. Previous Order No. R6T-2002-0031 established technology-based effluent limits to meet applicable secondary treatment standards. These effluent limitations have been carried over from the previous Order. Further, mass-based effluent limitations are based on a design flow rate of 2.0 MGD.

Table F-5. Basis for Limitations

Constituents	Basis for Limitations
Biochemical Oxygen Demand (BOD)	Discharges to waters that support aquatic life forms that are dependent on oxygen. Organic matter in the discharge may consume oxygen as it breaks down. Receiving waters may be effluent dominated at times.
Total Suspended Solids (TSS)	High levels of suspended solids can adversely impact aquatic habitat. Untreated or improperly treated wastewater can contain high amounts of suspended solids. Receiving waters may be effluent dominated at times.
Hydrogen Ion (pH)	Hydrogen ion (pH) is a measure of hydrogen ion concentration in the water. A range between 6.0 and 9.0 ensures suitability for biological life. The Basin Plan specifies pH of the receiving water must be between 6.5 and 8.5. Receiving waters may be effluent dominated at times.
Flow	The design capacity of the treatment plant based on average daily flow is currently 2.0 MGD.

C. Water Quality-Based Effluent Limitations (WQBELs)

1. Scope and Authority

Section 301(b) of the CWA and section 122.44(d) require that permits include limitations more stringent than applicable federal technology-based requirements where necessary to achieve applicable water quality standards.

Section 122.44(d)(1)(i) mandates that permits include effluent limitations for all pollutants that are or may be discharged at levels that have the reasonable potential to cause or contribute to an exceedance of a water quality standard, including numeric and narrative objectives within a standard. Where reasonable potential has been established for a pollutant, but there is no numeric criterion or objective for the pollutant, water quality-based effluent limitations (WQBELs) must be established using: (1) USEPA criteria guidance under CWA section 304(a), supplemented where necessary by other relevant information; (2) an indicator parameter for the pollutant of concern; or (3) a calculated numeric water quality criterion, such as a proposed state criterion or policy interpreting the state's narrative criterion, supplemented with other relevant information, as provided in section 122.44(d)(1)(vi).

The process for determining reasonable potential and calculating WQBELs when necessary is intended to protect the designated uses of the receiving water as specified in the Basin Plan, and achieve applicable water quality objectives and criteria that are contained in other state plans and policies, or any applicable water quality criteria contained in the CTR and NTR.

2. Applicable Beneficial Uses and Water Quality Criteria and Objectives

Table F-6 summarizes the applicable water quality criteria/objectives for priority pollutants reported in detectable concentrations in the effluent. These criteria were used in conducting the Reasonable Potential Analysis for this Order.

Some water quality criteria are hardness dependent. The Discharger provided hardness data for the receiving water (Jensen Slough) as part of their required CTR monitoring. The hardness value reported for the Jensen Slough is 110 mg/L CaCO₃. The Discharger provided a single hardness value; therefore, 110 mg/L was used for evaluation of reasonable potential.

Jensen Slough does not have specific receiving water quality objectives. The nearest numeric surface water quality objective established downstream of the discharge is for the Susan River at Litchfield, a location several miles away from the point of wastewater discharge and subject to the influences of land and water uses in the areas below the point of wastewater discharge.

The receiving water quality objectives have not been used as effluent limits in prior Permits for the Facility. However, the discharge may not cause or contribute to

violations or excursions from receiving water objectives. In preparing this permit, Water Board staff reviewed a limited amount of data on the Susan River at Litchfield that has been collected for other purposes. A summary table of this data is presented below, together with effluent data from the Discharger. Table F-6 shows that the water quality objective (annual average) for total dissolved solids is exceeded but total nitrogen and total phosphorus has not been exceeded (on an annual average).

Table F-6. Comparison of Water Quality Objectives vs Effluent

	Water Quality Objective			
	Annual Average mg/l	Maximum mg/l	Susan River at Litchfield ¹ mg/l	Effluent ² mg/l
Total Dissolved Solids	185	250	234	339
Total Nitrogen	0.65	0.85	0.49	8.2
Total Phosphorus	0.25	0.3	0.13	4.5
Boron	0.1	0.2	No data	17.3

¹ Based of Water Board data from the Surface Water Ambient Monitoring program (averages)

² Based of a summary data table from data from self monitoring report Mar 2001 – Feb 2005 (averages)

Based on the data in the table, the TDS concentrations from the discharge may cause or contribute to the elevated levels of TDS at Litchfield, whereas both the total nitrogen and total phosphorus appear to be attenuated (these water quality objectives are not violated). The receiving water quality objectives for the Susan River were not used as effluent limits but remain as receiving water limits.

This permit includes revised monitoring and reporting requirements and monitoring of the receiving water in a manner which has not been done previously, to better understand the impacts of the discharge on the receiving waters. The additional information will assist in determining if the discharge is causing or contributing to violations of receiving water quality objectives, and whether additional WQBELs are needed.

Table F-7. Applicable Water Quality Criteria

CTR No.	Constituent	Selected Criteria μg/L	CTR/NTR Water Quality Criteria					
			Freshwater		Saltwater		Human Health for Consumption of:	
			Acute μg/L	Chronic μg/L	Acute μg/L	Chronic μg/L	Water & Organisms μg/L	Organisms only μg/L
13	Zinc	129.89	129.89	129.89	N/A	N/A	--	--
26	Chloroform	No Criteria	--	--	N/A	N/A	--	--
39	Toluene	6800	--	--	N/A	N/A	6800	200,000

"N/A" indicates the receiving water is not characterized as saltwater, nor are the water quality criteria for the protection of human health for the consumption of water and organisms applicable.

Priority pollutant water quality criteria in the CTR are applicable to the Jensen Slough. The CTR contains both saltwater and freshwater criteria. Because a distinct separation generally does not exist between freshwater and saltwater aquatic communities, the following apply, in accordance with section 131.38(c)(3), freshwater criteria apply at salinities of 1 part per thousand (ppt) and below at locations where this occurs 95 percent or more of the time. The CTR criteria for freshwater or human health for consumption of organisms, whichever is more stringent, are used to prescribe the effluent limitations in this Order to protect the beneficial uses of the Jensen Slough, a water of the United States in the vicinity of the discharge.

The receiving water may be effluent dominated during summer months and at that time there is no significant amount of receiving water at the point of discharge. Therefore, no mixing zone allowance is included in the calculation of effluent limits. Consequently, compliance with the effluent limits is required to be determined at a location prior to where the discharge enters the receiving water.

3. Determining the Need for WQBELs

In accordance with Section 1.3 of the SIP, the Lahontan Water Board conducts a reasonable potential analysis (RPA) for each priority pollutant with an applicable criterion or objective to determine if a WQBEL is required in the permit. The Lahontan Water Board analyzes effluent and receiving water data and identifies the maximum observed effluent concentration (MEC) and maximum background concentration (B) in the receiving water for each constituent. To determine reasonable potential, the MEC and the B are then compared with the applicable water quality objectives (C) outlined in the CTR, NTR, as well as the Basin Plan. For all pollutants that have a reasonable potential to cause or contribute to an excursion above a state water quality standard, numeric WQBELs are required. The RPA considers water quality criteria from the CTR and NTR, and when applicable, water quality objectives specified in the Basin Plan. To conduct the RPA, the Lahontan Water Board identifies the MEC and maximum background concentration in the receiving water for each constituent, based on data provided by the Discharger.

Section 1.3 of the SIP provides the procedures for determining reasonable potential to exceed applicable water quality criteria and objectives. The SIP specifies three triggers to complete a RPA:

- a. Trigger 1 – If the $MEC \geq C$, a limit is needed.
- b. Trigger 2 – If the background concentration (B) > C and the pollutant is detected in the effluent, a limit is needed.
- c. Trigger 3 – If other related information such as CWA 303(d) listing for a pollutant, discharge type, compliance history, etc. indicates that a WQBEL is required.

Sufficient effluent and receiving water data are needed to conduct a complete RPA. If data are not sufficient, the Discharger will be required to gather the appropriate data for the Lahontan Water Board to conduct the RPA. Upon review of the data, and if the Lahontan Water Board determines that WQBELs are needed to protect the beneficial uses, the permit will be reopened for appropriate modification.

Three sets of CTR tested discharge data are available for Discharge Point 001. One set of receiving water data for the Jensen Slough was available, but it was determined that this data had been influenced by the effluent and unacceptable for use in the RPA calculations.

The Discharger provided data collected from 2002 to 2006 to evaluate reasonable potential. The RPA was performed for the priority pollutants for which effluent data were available, as summarized in Table F-7. The Lahontan Water Board evaluated monitoring data for zinc, chloroform, and toluene and determined WQBELs were not required for these pollutants. In accordance with Section 1.2 of the SIP, the Lahontan Water Board shall have discretion to consider if any data are inappropriate for use in determining reasonable potential. Further, to provide additional data for evaluating reasonable potential, this Order requires the Discharger to conduct annual effluent monitoring for priority pollutants and submit the laboratory results in accordance with the requirements contained in Section 2.4.2 of the SIP.

Table F-8. Summary Reasonable Potential Analysis

CTR No.	Priority Pollutant	Applicable Water Quality Criteria (C)	Max Effluent Conc (MEC)	Maximum Detected Receiving Water Conc. (B)	RPA Result - Need Limit?	Reason
		µg/L	µg/L	µg/L		
13	Zinc	129.89	70	N/A ¹	No	Ud; MEC < C & no B
26	Chloroform	No Criteria	0.83	N/A ¹	No	No Criteria
39	Toluene	6800	2.3	N/A ¹	No	Ud; MEC < C & no B

¹ There was insufficient data for detected receiving water concentrations, additionally the receiving water is effluent dominated for part of the year.

4. WQBEL Calculations

The Reasonable Potential Analysis conducted on monitoring data CTR constituents submitted by the Discharger found the discharge did not have a reasonable potential to cause or threaten to cause an exceedance of applicable water quality standards. Therefore, this Order does not implement any water quality based effluent limits (final) in this Order for CTR constituents.

5. WQBELs Based on Basin Plan Objectives

- a. In fresh waters with designated beneficial uses of COLD or WARM, changes in normal ambient pH levels shall not exceed 0.5 pH units. For all other waters of the Region, the pH shall not be depressed below 6.5 nor raised above 8.5.
- b. For waters designated WARM, water temperature shall not be altered by more than five degrees Fahrenheit (5°F) above or below the natural temperature. For waters designated COLD, the temperature shall not be altered.
- c. Waters shall not contain substances in concentrations that result in deposition of material that causes nuisance or that adversely affects the water for beneficial uses. For natural high quality waters, the concentration of settleable materials shall not be raised by more than 0.1 milliliter per liter.
- d. The effluent shall not contain trace elements, pollutants, contaminants, or combinations thereof, in concentrations which are more toxic or harmful to human, aquatic, terrestrial plant or animal life.

6. WQBELs Based on Title 22 "California Health Laws Related to Recycled Water"

Section 60301.225. Disinfected secondary-23 recycled water states that: "Disinfected secondary-23 recycled water" means recycled water that has been oxidized and disinfected so that the median concentration of total coliform bacteria in the disinfected effluent does not exceed a most probable number (MPN) of 23 per 100 milliliters utilizing the bacteriological results of the last seven days for which analyses have been completed, and the number of total coliform bacteria does not

exceed an MPN of 240 per 100 milliliters in more than one sample in any 30 day period.

7. WQBELs Based on State Water Board Policy

- a) Chlorine Residual. The Basin Plans general surface water objectives state that all waters shall be maintained free of toxic substances in concentrations which are toxic to, or which produce detrimental physiological responses in human, plant, animal, or indigenous aquatic life. Chlorine is known to be toxic to aquatic life. The previous Order establishes numeric for total chlorine that stated: "For the protection of aquatic life, total chlorine residual shall not exceed either a median value of 0.002 mg/L or a maximum value of 0.003 mg/L."

The State Water Resources Control Board has issued a draft policy, the "Total Residual Chlorine and Chlorine-Produced Oxidants Policy of California" which establishes total residual chlorine objectives that apply to all inland surface waters and enclosed bays and estuaries in California. The draft Policy proposes effluent limitations for Total Chlorine Residual as: Average Monthly Effluent Limitation - 0.01 mg/L and the Instantaneous Maximum Effluent Limitation - 0.02 mg/L.

This Policy when final will supersede any and all numeric total residual chlorine objectives and implementation provisions previously contained in Regional Water Quality Control Plans (Basin Plans) for the same waters. The Lahontan Water Board has decided to apply these limits at this time of renewal – compliance schedules are appropriate for existing discharges if requested from the permitting authority.

Summary of Water Quality-based Effluent Limitations Discharge Point 001

Table F-9. Summary of Water Quality-based Effluent Limitations

Parameter	Units	Effluent Limitations				
		Average Monthly	Average Weekly	Maximum Daily	Instantaneous Minimum	Instantaneous Maximum
pH	Standard Units	--	--	--	6.5	8.5
Residual Chlorine	mg/L	0.01	--	--	--	0.02

8. Whole Effluent Toxicity (WET)

Whole effluent toxicity (WET) protects the receiving water quality from the aggregate toxic effect of a mixture of pollutants in the effluent. In this case the receiving waters may consist solely or mainly of effluent during certain times of the year. WET tests measure the degree of response of exposed aquatic test organisms to an effluent. The WET approach allows for protection of the narrative "no toxics in toxic amounts" criterion while implementing numeric criteria for toxicity. There are two types of WET tests: acute and chronic. An acute toxicity test is conducted over a short time

period and measures mortality. A chronic toxicity test is conducted over a longer period of time and may measure mortality, reproduction, and growth.

The Basin Plan specifies a narrative objective for toxicity, requiring that all waters be maintained free of toxic substances in concentrations that are lethal to or produce other detrimental responses by aquatic organisms. Detrimental response includes but is not limited to decreased growth rate, decreased reproductive success of resident or indicator species, and/or significant alterations in population, community ecology, or receiving water biota.

The Basin Plan states, at page 3-16, that for acute toxicity, compliance shall be determined by short-term toxicity tests on undiluted effluent using an established protocol (e.g., American Society for Testing and Materials [ASTM], American Public Health Association, USEPA, State Board). For chronic toxicity, compliance shall be determined using the critical life stage (CLS) toxicity tests. At least three approved species shall be used to measure compliance with the toxicity objective. If possible, test species shall include a vertebrate, an invertebrate, and an aquatic plant. After an initial screening period, monitoring may be reduced to the most sensitive species. Dilution and control waters should be obtained from an unaffected area of the receiving waters. For rivers and streams, dilution water should be obtained immediately upstream of the discharge. Standard dilution water can be used if the above sources exhibit toxicity greater than 1.0 chronic toxicity units (TU_c).

Annual acute toxicity data for 2006 submitted by the Discharger indicate greater than 90% survival rates. Consistent with Basin Plan requirements, this Order carries over the narrative acute toxicity limitations from the previous Order, monitoring requirements have been modified.

In addition to the Basin Plan requirements, Section 4 of the SIP states that a chronic toxicity effluent limitation is required in permits for all discharges that will cause, have the reasonable potential to cause, or contribute to chronic toxicity in receiving waters. The discharges from Discharge Point 001 could contribute to long-term toxic effects within the receiving water. Annual chronic toxicity data for the 2006 Discharger indicated a chronic toxicity of 1 TU_c. Consistent with Basin Plan requirements, this Order carries over the narrative acute toxicity limitations from the previous Order. Monitoring requirements have been modified to increase monitoring for both acute and chronic toxicity and will include alga whole effluent testing.

D. Final Effluent Limitations

1. Satisfaction of Anti-Backsliding Requirements

Sections 402(o)(2) and 303(d)(4) of the CWA and federal regulations at title 40, Code of Federal Regulations section 122.44(l) prohibit backsliding in NPDES permits. These anti-backsliding provisions require that effluent limitations in a reissued permit must be as stringent as those in the previous permit, with some exceptions in which limitations may be relaxed. All effluent limitations in this Order are at least as stringent as the effluent limitations in the previous Order.

2. Satisfaction of Antidegradation Policy

Section 131.12 requires that the state water quality standards include an anti-degradation policy consistent with the federal policy. The State Water Board established California's antidegradation policy in State Water Board Resolution No. 68-16. Resolution No. 68-16 incorporates the federal antidegradation policy where the federal policy applies under federal law. Resolution No. 68-16 requires that existing water quality be maintained unless degradation is justified based on specific findings. The Lahontan Water Board's Basin Plan implements, and incorporates by reference, both the State and federal antidegradation policies.

The permitted discharge is consistent with the antidegradation provision of section 131.12 and State Water Board Resolution No. 68-16 and the final limitations in this Order are in compliance with antidegradation requirements and meet the requirements of the SIP because these limits hold the Discharger to performance levels that will not cause or contribute to water quality impairment or further quality degradation that could result from and increase in permitted design flow or a reduction in the level of treatment. This Order does not provide for an increase in the permitted design flow or allow for a reduction in the level of treatment. Further, compliance with these requirements will result in the use of best practicable treatment or control of the discharge.

The Order allows only the level of discharge authorized in the previous permit and thus there will be no change in water quality beyond the level that was authorized in the last permit. Findings authorizing degradation are thus not appropriate.

3. Stringency of Requirements for Individual Pollutants

This Order contains both technology-based and water quality-based effluent limitations for individual pollutants. The technology-based effluent limitations consist of restrictions on BOD₅, TSS, and removal efficiency for both BOD and TSS. Restrictions on the above pollutants are discussed in Section IV.B.1. This Order's technology-based pollutant restrictions implement the minimum, applicable federal technology-based requirements. In addition, this Order contains effluent limitations more stringent than the minimum, federal technology-based requirements that are necessary to meet water quality standards. These requirements include limitations for chlorine residual that are more stringent than required by the CWA.

This Order contains pollutant restrictions that are more stringent than applicable federal requirements and standards. Specifically, this Order includes effluent limitations for pH that are more stringent than applicable federal standards, but that are nonetheless necessary to meet numeric objectives or protect beneficial uses. The rationale for including these limitations is explained in Section VI.C.3.

**Summary of Final Effluent Limitations
Discharge Point 001**

Table F-10. Summary of Final Effluent Limitations

Parameter	Units	Effluent Limitations				
		Average Monthly	Average Weekly	Maximum Daily	Instantaneous Minimum	Instantaneous Maximum
Daily Effluent Flow	MGD	2.0	---	---	---	---
Biochemical Oxygen Demand (BOD) (5-day @ 20 Deg. C)	mg/L	30	45	---	---	---
	lbs/day ¹	500	751	---	---	---
Total Suspended Solids (TSS)	mg/L	30	45	---	---	---
	lbs/day ¹	500	751	---	---	---
pH	pH units	---	---	---	6.5	8.5
Removal Efficiency for BOD and TSS	%	85	---	---	---	---
Residual Chlorine	mg/L	0.01	---	---	---	0.02

“---” No effluent limitation is applicable.

¹ The mass-based effluent limitations are based on a design capacity of 2.0 MGD.

- a) In fresh waters with designated beneficial uses of COLD or WARM, changes in normal ambient pH levels shall not exceed 0.5 pH units. For all other waters of the Region, the pH shall not be depressed below 6.5 nor raised above 8.5.
- b) For waters designated WARM, water temperature shall not be altered by more than five degrees Fahrenheit (5°F) above or below the natural temperature. For waters designated COLD, the temperature shall not be altered.
- c) Waters shall not contain substances in concentrations that result in deposition of material that causes nuisance or that adversely affects the water for beneficial uses. For natural high quality waters, the concentration of settleable materials shall not be raised by more than 0.1 milliliter per liter.
- d) The effluent shall not contain trace elements, pollutants, contaminants, or combinations thereof, in concentrations which are more toxic or harmful to human, aquatic, terrestrial plant or animal life.

E. Interim Effluent Limitations – Not Applicable

F. Land Discharge Specifications – Not Applicable

G. Reclamation Specifications- Not Applicable

V. RATIONALE FOR RECEIVING WATER LIMITATIONS

The receiving water limitations in the Order are based upon the water quality objectives contained in the Basin Plan. As such, they are a required part of the Order.

A. Surface Water

1. The receiving water limitations in the proposed Order are based upon the water quality objectives contained in the Basin Plan and are carried forward from the previous Order. As such, they are a required part of the proposed Order.
2. The discharge shall not cause the following limits to be exceeded in the Susan River and its tributaries:

Table F-11. Receiving Water Limitations

Parameter	Units	Receiving Water Limitation	
		Annual Mean	Maximum
Total Dissolved Solids	mg/L	185	250
Chloride	mg/L	4.2	7.5
Total Nitrogen	mg/L	0.65	0.85
Total Phosphorus	mg/L	0.25	0.30
Sulfate	mg/L	25	40
Un-ionized Ammonia	mg/L	--	0.025
Boron	mg/L	0.1	0.2
ASAR	--	2.5	--

The Adjusted Sodium Adsorption Ratio (ASAR) is calculated by the following equation. All values of Ca, Na and Mg must be reported as milliequivalents per liter.

$$ASAR = \frac{Na}{\sqrt{\frac{Ca + Mg}{2}}} \times (1 + (8.4 - pH_c))$$

The values for pH_c can be found in the Water Boards Basin Plan Appendix E.

3. If the constituent concentration of the receiving water just above the discharge point exceeds the level in Table F-10, the discharge shall not cause a statistically significant increase (at a 90 percent confidence level) in the concentration below the discharge point when compared to the concentration upstream of the discharge.
4. Water Quality Objectives Which Apply to All Surface Waters: these narrative and numerical water quality objectives apply to all surface waters (including wetlands)

within the Lahontan Region and can be found at section 3-3 of the Basin Plan. The discharge of flows, generated within, or as a result of the facility, to surface water shall not cause a violation of the following water quality objectives for the waters of the Susan River Hydrologic Area, They include:

Ammonia	Pesticides
Bacteria, Coliform	pH
Biostimulatory Substances	Radioactivity
Sediment	Settleable Materials
Chemical Constituents	Suspended Materials
Chlorine, Total Residual	Taste and Odor
Color	Temperature
Dissolved Oxygen	Toxicity
Floating Materials	Turbidity
Oil and Grease	
Non-degradation of Aquatic Communities and Populations	

5. **Water Quality Objectives for Certain Water Bodies:** some narrative and numerical water quality objectives are directed toward protection of surface waters (including wetlands) in specific areas. To the extent of the overlap, these site specific water quality objectives supersede all "Water Quality Objectives Which Apply to All Surface Waters" described above. The areas for which site specific objectives have been adopted are determined by hydrologic units (HU) and hydrologic areas (HA) within the Lahontan Region. The facility is within the Susanville HU, (Figure 3-3 of the Basin Plan) and specific water quality objectives can be found on Table 3-9 of the Basin Plan.
6. The Basin Plan does not have specific water quality objectives for the Jensen Slough. The Jensen Slough originates from a diversion structure on the Susan River and is used to irrigate ranchlands and/or supply water for livestock before returning to the Susan River. Lands served by the Jensen Slough are pastures for non-milk-producing animals. There may be periods in which little or no freshwater flow (from diversion) is present in Jensen Slough.

Effluent discharged to the constructed irrigation channel (Discharge Point 001) enters the Jensen Slough at a point just above Monitoring Point RSW-002 unless the effluent is fully used for irrigation. The Jensen Slough, after its confluence with the irrigation channel, continues toward the Susan River. Unused water in the Jensen Slough returns to the Susan River and may be a mixture of freshwater and wastewater mixed with tailwater returned as overland flow from irrigation operations. There are times during the winter season when little or no irrigation occurs and flow in Jensen Slough reaches the Susan River directly.

The nearest location on the Susan River with numeric water quality objectives downstream of the confluence with Jensen Slough is the Susan River at Litchfield, which is several miles below the confluence of the constructed irrigation channel and the Jensen Slough. Previous permits have used the water quality objectives for the Susan River at Litchfield as the receiving water objectives for the permit. Because the Jensen Slough is tributary to the Susan River, this permit continues to use the

water quality objectives for the Susan River at Litchfield based on the Basin Plan's "tributary rule," which provides that water quality standards for specific waterbodies apply upstream to tributaries for which no site-specific standards have been adopted."

B. Groundwater

1. The ground water limitations in the proposed Order are based upon the water quality objectives contained in the Basin Plan and are carried forward from the previous Order. As such, they are a required part of the proposed Order.
2. The discharge shall not cause a violation of the following water quality objectives for the waters of the Honey Lake Ground Water Basin:

Bacteria, Coliform
Radioactivity

Chemical Constituents
Tastes and Odors

VI. RATIONALE FOR MONITORING AND REPORTING REQUIREMENTS

Section 122.48 requires that all NPDES permits specify requirements for recording and reporting monitoring results. Water Code sections 13267 and 13383 authorizes the Lahontan Water Board to require technical and monitoring reports. The Monitoring and Reporting Program (MRP), Attachment E of this Order, establishes monitoring and reporting requirements to implement federal and state requirements. The following provides the rationale for the monitoring and reporting requirements contained in the MRP for this facility.

A. Influent Monitoring

This Order carries forward the treatment plant influent monitoring requirements.

B. Effluent Monitoring

The Discharger is required to conduct monitoring of the permitted discharges in order to evaluate compliance with permit conditions. Monitoring requirements are given in the proposed MRP. This provision requires compliance with the Monitoring and Reporting Program, and is based on sections 122.44(i), 122.62, 122.63 and 124.5. The MRP is a standard requirement in almost all NPDES permits (including the proposed Order) issued by the Lahontan Water Board. In addition to containing definitions of terms, it specifies general sampling/analytical protocols and the requirements of reporting of spills, violations, and routine monitoring data in accordance with NPDES regulations, the CWC, and Lahontan Water Board's policies. The MRP also contains sampling program specific for the Discharger's wastewater treatment facility. It defines the sampling stations and frequency, pollutants to be monitored, and additional reporting requirements. Pollutants to be monitored include all pollutants for which effluent limitations are specified. Further, in accordance with section 1.3 of the SIP, periodic monitoring is required for all priority pollutants defined by the CTR, for which criteria apply and for which no effluent limitations have been established, to evaluate

reasonable potential to cause or contribute to an excursion above a water quality standard

C. Whole Effluent Toxicity Testing Requirements

Whole effluent toxicity (WET) protects the receiving water quality from the aggregate toxic effect of a mixture of pollutants in the effluent. An acute toxicity test is conducted over a short time period and measures mortality. A chronic toxicity test is conducted over a longer period of time and may measure mortality, reproduction, and growth.

This WET testing requirement establishes conditions and protocols by which compliance with the Basin Plan narrative water quality objective for toxicity will be demonstrated and is in accordance with section 4.0 of the SIP. Conditions include required monitoring and evaluation of the effluent for acute and chronic toxicity and numerical values for chronic toxicity evaluation to be used as 'triggers' for initiating accelerated monitoring and toxicity reduction evaluation(s).

The WET testing requirements contained in the MRP, Section V were developed based on the Draft National Whole Effluent Toxicity Implementation Guidance Under the NPDES Program developed by USEPA (Docket ID. No. OW-2004-0037). This is the most current guidance available to the Lahontan Water Board. This Order includes a reopener to allow the requirements of this section to be revised pending the issuance of final guidance or policies developed by either the USEPA or State Water Board.

D. Receiving Water Monitoring

1. Surface Water

Surface water monitoring is required to determine compliance with receiving water limitations and to characterize the water quality of the receiving water pursuant to the SIP and Basin Plan. Monitoring frequencies for all constituents carried forward from the previous Order have been retained. In addition to downstream surface water monitoring, receiving water monitoring has been established upstream of the effluent discharge point (RSW-001). In the event that no receiving water is present at station RSW-002, receiving water monitoring may be suspended until receiving water flow is present. Further, receiving water monitoring has been established at locations upstream from the confluence points of the Jensen Slough and Susan River; RSW-003 represents a monitoring location in the Jensen Slough above the confluence with the Susan River, and RSW-004 represents a monitoring location in the Susan River above the confluence with the Jensen Slough. These data will assist in evaluating existing receiving water conditions, assimilation capacity, and effects of the Facility's discharge on the receiving waters.

2. Groundwater – Not Applicable

E. Other Monitoring Requirements

Sludge Monitoring

Sludge monitoring and reporting requirements are based on the minimum information needed to determine appropriate sludge management.

VII. RATIONALE FOR PROVISIONS

A. Standard Provisions

Standard Provisions, which apply to all NPDES permits in accordance with section 122.41, and additional conditions applicable to specified categories of permits in accordance with section 122.42, are provided in Attachment D. The Discharger must comply with all standard provisions and with those additional conditions that are applicable under section 122.42.

Section 122.41(a)(1) and (b) through (n) establish conditions that apply to all State-issued NPDES permits. These conditions must be incorporated into the permits either expressly or by reference. If incorporated by reference, a specific citation to the regulations must be included in the Order. Section 123.25(a)(12) allows the state to omit or modify conditions to impose more stringent requirements. In accordance with section 123.25, this Order omits federal conditions that address enforcement authority specified in sections 122.41(j)(5) and (k)(2) because the enforcement authority under the Water Code is more stringent. In lieu of these conditions, this Order incorporates by reference Water Code section 13387(e).

B. Special Provisions

1. Reopener Provisions

This provision is based on 40 CFR Part 123. The Lahontan Water Board may reopen the permit to modify permit conditions and requirements under certain circumstances and with proper notice. Causes for modifications include the promulgation of new regulations, modification in sludge use or disposal practices, or adoption of new regulations by the State Water Board or Lahontan Water Board, including revisions to the Basin Plan.

2. Special Studies and Additional Monitoring Requirements

- a. **Priority Pollutant Monitoring.** This provision is based on the SIP. This provision requires the Discharger to implement monitoring and reporting methods established in the SIP, sections 2.3 and 2.4.
- b. **Toxicity Identification Evaluations or Toxicity Reduction Evaluations.** This provision is based on the SIP, section 4, Toxicity Control Provisions.

3. Best Management Practices and Pollution Prevention

Pollutant Minimization Program. This provision is based on the requirements of section 2.4.5 of the SIP.

4. Construction, Operation, and Maintenance Specifications

This provision is based on the requirements of 40 CFR §122.41(e) and the previous Order.

5. Special Provisions for Municipal Facilities (POTWs Only)

Sludge Disposal Requirements. Requirements are based on the minimum information needed to determine appropriate sludge management.

6. Other Special Provisions – Not Applicable

7. Compliance Schedules – Not Applicable

VIII. PUBLIC PARTICIPATION

The California Regional Water Quality Control Board, Lahontan Region (Lahontan Water Board) is considering the issuance of waste discharge requirements (WDRs) that will serve as a National Pollutant Discharge Elimination System (NPDES) permit for the Susanville Sanitary District Wastewater Treatment Plant. As a step in the WDR adoption process, the Lahontan Water Board staff has developed tentative WDRs. The Lahontan Water Board encourages public participation in the WDR adoption process.

A. Notification of Interested Parties

The Lahontan Water Board has notified the Discharger and interested agencies and persons of its intent to prescribe waste discharge requirements for the discharge and has provided them with an opportunity to submit their written comments and recommendations. Notification was provided through the Lassen County Times on June 10 and 24, 2008. As of June 20, 2008, no written comments were received.

B. Written Comments

The staff determinations are tentative. Interested persons are invited to submit written comments concerning draft WDRs. Comments must be submitted either in person or by mail to the Executive Office at the Lahontan Water Board at the address above on the cover page of this Order.

To be fully considered by staff and the Lahontan Water Board, written comments should be received at the Lahontan Water Board offices by 5:00 p.m. on June 27, 2008.

C. Public Hearing

The Lahontan Water Board will hold a public hearing on the proposed WDRs during its regular Board meeting on the following date and time and at the following location:

Date: July 23-24, 2008
Time: **To be determined**
Location: Town of Truckee Council Chambers
10183 Truckee Airport Road, Truckee CA 96161

Interested persons are invited to attend. At the public meeting, the Lahontan Water Board will hear testimony, if any, pertinent to the discharge, WDRs, and permit. Oral testimony will be heard; however, for accuracy of the record, important testimony should be in writing.

Please be aware that dates and venues may change. Our Web address is <http://www.waterboards.ca.gov/lahontan/> where you can access the current agenda for changes in dates and locations.

D. Waste Discharge Requirements Petitions

Any aggrieved person may petition the State Water Resources Control Board to review the decision of the Lahontan Water Board regarding the final WDRs. The petition must be submitted within 30 days of the Lahontan Water Board's action to the following address:

State Water Resources Control Board
Office of Chief Counsel
P.O. Box 100, 1001 I Street
Sacramento, CA 95812-0100

E. Information and Copying

The Report of Waste Discharge (RWD), related documents, proposed effluent limitations and special provisions, comments received, and other information are on file and may be inspected at the address above at any time between 8:30 a.m. and 4:45 p.m., Monday through Friday. Copying of documents may be arranged through the Lahontan Water Board by calling (530) 542-5400.

F. Register of Interested Persons

Any person interested in being placed on the mailing list for information regarding the WDRs and NPDES permit should contact the Lahontan Water Board, reference this facility, and provide a name, address, and phone number.

G. Additional Information

Requests for additional information or questions regarding this order should be directed to Rob Tucker at (530) 542-5467.

ATTACHMENT G

06-0095

ATTACHMENT G – LIST OF PRIORITY POLLUTANTS

CTR Number	Parameter	CAS Number	Suggested Analytical Methods
1	Antimony	7440360	EPA 6020/200.8
2	Arsenic	7440382	EPA 1632
3	Beryllium	7440417	EPA 6020/200.8
4	Cadmium	7440439	EPA 1638/200.8
5a	Chromium (III)	16065831	EPA 6020/200.8
5a	Chromium (VI)	18540299	EPA 7199/1636
6	Copper	7440508	EPA 6020/200.8
7	Lead	7439921	EPA 1638
8	Mercury	7439976	EPA 1669/1631
9	Nickel	7440020	EPA 6020/200.8
10	Selenium	7782492	EPA 6020/200.8
11	Silver	7440224	EPA 6020/200.8
12	Thallium	7440280	EPA 6020/200.8
13	Zinc	7440666	EPA 6020/200.8
14	Cyanide	57125	EPA 9012A
15	Asbestos	1332214	EPA/600/R-93/116(PCM)
16	2,3,7,8-TCDD	1746016	EPA 8290 (HRGC) MS
17	Acrolein	107028	EPA 8260B
18	Acrylonitrile	107131	EPA 8260B
19	Benzene	71432	EPA 8260B
20	Bromoform	75252	EPA 8260B
21	Carbon Tetrachloride	56235	EPA 8260B
22	Chlorobenzene	108907	EPA 8260B
23	Chlorodibromomethane	124481	EPA 8260B
24	Chloroethane	75003	EPA 8260B
25	2-Chloroethylvinyl Ether	110758	EPA 8260B
26	Chloroform	67663	EPA 8260B
27	Dichlorobromomethane	75274	EPA 8260B
28	1,1-Dichloroethane	75343	EPA 8260B
29	1,2-Dichloroethane	107062	EPA 8260B
30	1,1-Dichloroethylene	75354	EPA 8260B
31	1,2-Dichloropropane	78875	EPA 8260B
32	1,3-Dichloropropylene	542756	EPA 8260B
33	Ethylbenzene	100414	EPA 8260B
34	Methyl Bromide	74839	EPA 8260B
35	Methyl Chloride	74873	EPA 8260B
36	Methylene Chloride	75092	EPA 8260B
37	1,1,2,2-Tetrachloroethane	79345	EPA 8260B
38	Tetrachloroethylene	127184	EPA 8260B
39	Toluene	108883	EPA 8260B
40	1,2-Trans-Dichloroethylene	156605	EPA 8260B

CTR Number	Parameter	CAS Number	Suggested Analytical Methods
41	1,1,1-Trichloroethane	71556	EPA 8260B
42	1,1,2-Trichloroethane	79005	EPA 8260B
43	Trichloroethylene	79016	EPA 8260B
44	Vinyl Chloride	75014	EPA 8260B
45	2-Chlorophenol	95578	EPA 8270C
46	2,4-Dichlorophenol	120832	EPA 8270C
47	2,4-Dimethylphenol	105679	EPA 8270C
48	2-Methyl-4,6-Dinitrophenol	534521	EPA 8270C
49	2,4-Dinitrophenol	51285	EPA 8270C
50	2-Nitrophenol	88755	EPA 8270C
51	4-Nitrophenol	100027	EPA 8270C
52	3-Methyl-4-Chlorophenol	59507	EPA 8270C
53	Pentachlorophenol	87865	EPA 8270C
54	Phenol	108952	EPA 8270C
55	2,4,6-Trichlorophenol	88062	EPA 8270C
56	Acenaphthene	83329	EPA 8270C
57	Acenaphthylene	208968	EPA 8270C
58	Anthracene	120127	EPA 8270C
59	Benzidine	92875	EPA 8270C
60	Benzo(a)Anthracene	56553	EPA 8270C
61	Benzo(a)Pyrene	50328	EPA 8270C
62	Benzo(b)Fluoranthene	205992	EPA 8270C
63	Benzo(ghi)Perylene	191242	EPA 8270C
64	Benzo(k)Fluoranthene	207089	EPA 8270C
65	Bis(2-Chloroethoxy)Methane	111911	EPA 8270C
66	Bis(2-Chloroethyl)Ether	111444	EPA 8270C
67	Bis(2-Chloroisopropyl)Ether	108601	EPA 8270C
68	Bis(2-Ethylhexyl)Phthalate	117817	EPA 8270C
69	4-Bromophenyl Phenyl Ether	101553	EPA 8270C
70	Butylbenzyl Phthalate	85687	EPA 8270C
71	2-Chloronaphthalene	91587	EPA 8270C
72	4-Chlorophenyl Phenyl Ether	7005723	EPA 8270C
73	Chrysene	218019	EPA 8270C
74	Dibenzo(a,h)Anthracene	53703	EPA 8270C
75	1,2-Dichlorobenzene	95501	EPA 8260B
76	1,3-Dichlorobenzene	541731	EPA 8260B
77	1,4-Dichlorobenzene	106467	EPA 8260B
78	3,3'-Dichlorobenzidine	91941	EPA 8270C
79	Diethyl Phthalate	84662	EPA 8270C
80	Dimethyl Phthalate	131113	EPA 8270C
81	Di-n-Butyl Phthalate	84742	EPA 8270C
82	2,4-Dinitrotoluene	121142	EPA 8270C
83	2,6-Dinitrotoluene	606202	EPA 8270C
84	Di-n-Octyl Phthalate	117840	EPA 8270C

CTR Number	Parameter	CAS Number	Suggested Analytical Methods
85	1,2-Diphenylhydrazine	122667	EPA 8270C
86	Fluoranthene	206440	EPA 8270C
87	Fluorene	86737	EPA 8270C
88	Hexachlorobenzene	118741	EPA 8260B
89	Hexachlorobutadiene	87863	EPA 8260B
90	Hexachlorocyclopentadiene	77474	EPA 8270C
91	Hexachloroethane	67721	EPA 8260B
92	Indeno(1,2,3-cd)Pyrene	193395	EPA 8270C
93	Isophorone	78591	EPA 8270C
94	Naphthalene	91203	EPA 8260B
95	Nitrobenzene	98953	EPA 8270C
96	N-Nitrosodimethylamine	62759	EPA 8270C
97	N-Nitrosodi-n-Propylamine	621647	EPA 8270C
98	N-Nitrosodiphenylamine	86306	EPA 8270C
99	Phenanthrene	85018	EPA 8270C
100	Pyrene	129000	EPA 8270C
101	1,2,4-Trichlorobenzene	120821	EPA 8260B
102	Aldrin	309002	EPA 8081A
103	alpha-BHC	319846	EPA 8081A
104	beta-BHC	319857	EPA 8081A
105	gamma-BHC	58899	EPA 8081A
106	delta-BHC	319868	EPA 8081A
107	Chlordane	57749	EPA 8081A
108	4,4'-DDT	50293	EPA 8081A
109	4,4'-DDE	72559	EPA 8081A
110	4,4'-DDD	72548	EPA 8081A
111	Dieldrin	60571	EPA 8081A
112	alpha-Endosulfan	959988	EPA 8081A
113	beta-Endosulfan	33213659	EPA 8081A
114	Endosulfan Sulfate	1031078	EPA 8081A
115	Endrin	72208	EPA 8081A
116	Endrin Aldehyde	7421934	EPA 8081A
117	Heptachlor	76448	EPA 8081A
118	Heptachlor Epoxide	1024573	EPA 8081A
119	PCB-1016	12674112	EPA 8082
120	PCB-1221	11104282	EPA 8082
121	PCB-1232	11141165	EPA 8082
122	PCB-1242	53469219	EPA 8082
123	PCB-1248	12672296	EPA 8082
124	PCB-1254	11097691	EPA 8082
125	PCB-1260	11096825	EPA 8082
126	Toxaphene	8001352	EPA 8081A

ATTACHMENT H

06-0099

ATTACHMENT H – STATE WATER BOARD MINIMUM LEVELS

The State Water Board Minimum Levels (MLs) in this appendix are for use in reporting and compliance determination purposes in accordance with Section 2.4 of the State Implementation Policy. These MLs were derived from data for priority pollutants provided by State certified analytical laboratories in 1997 and 1998. These MLs shall be used until new values are adopted by the State Water Board and become effective. The following tables (Tables 2a - 2d) present MLs for four major chemical groupings: volatile substances, semi-volatile substances, inorganics, and pesticides and PCBs. The MLs in this appendix are in parts per billion ($\mu\text{g/L}$).

Table H-1 Volatile Substances

Table 2a - VOLATILE SUBSTANCES*	GC	GCMS
1,1 Dichloroethane	0.5	1
1,1 Dichloroethylene	0.5	2
1,1,1 Trichloroethane	0.5	2
1,1,2 Trichloroethane	0.5	2
1,1,2,2 Tetrachloroethane	0.5	1
1,2 Dichlorobenzene (volatile)	0.5	2
1,2 Dichloroethane	0.5	2
1,2 Dichloropropane	0.5	1
1,3 Dichlorobenzene (volatile)	0.5	2
1,3 Dichloropropene (volatile)	0.5	2
1,4 Dichlorobenzene (volatile)	0.5	2
Acrolein	2.0	5
Acrylonitrile	2.0	2
Benzene	0.5	2
Bromoform	0.5	2
Methyl Bromide	1.0	2
Carbon Tetrachloride	0.5	2
Chlorobenzene	0.5	2
Chlorodibromo-methane	0.5	2
Chloroethane	0.5	2
Chloroform	0.5	2
Chloromethane	0.5	2
Dichlorobromo-methane	0.5	2
Dichloromethane	0.5	2
Ethylbenzene	0.5	2
Tetrachloroethylene	0.5	2
Toluene	0.5	2
Trans-1,2 Dichloroethylene	0.5	1
Trichloroethene	0.5	2
Vinyl Chloride	0.5	2

*The normal method-specific factor for these substances is 1; therefore, the lowest standard concentration in the calibration curve is equal to the above ML value for each substance.

Table H-2 Semi-Volatile Substances

Table 2b - SEMI-VOLATILE SUBSTANCES*	GC	GCMS	LC	COLOR
Benzo (a) Anthracene	10	5		
1,2 Dichlorobenzene (semivolatile)	2	2		
1,2 Diphenylhydrazine		1		
1,2,4 Trichlorobenzene	1	5		
1,3 Dichlorobenzene (semivolatile)	2	1		
1,4 Dichlorobenzene (semivolatile)	2	1		
2 Chlorophenol	2	5		
2,4 Dichlorophenol	1	5		
2,4 Dimethylphenol	1	2		
2,4 Dinitrophenol	5	5		
2,4 Dinitrotoluene	10	5		
2,4,6 Trichlorophenol	10	10		
2,6 Dinitrotoluene		5		
2- Nitrophenol		10		
2-Chloroethyl vinyl ether	1	1		
2-Chloronaphthalene		10		
3,3' Dichlorobenzidine		5		
Benzo (b) Fluoranthene		10	10	
3-Methyl-Chlorophenol	5	1		
4,6 Dinitro-2-methylphenol	10	5		
4- Nitrophenol	5	10		
4-Bromophenyl phenyl ether	10	5		
4-Chlorophenyl phenyl ether		5		
Acenaphthene	1	1	0.5	
Acenaphthylene		10	0.2	
Anthracene		10	2	
Benzidine		5		
Benzo(a) pyrene		10	2	
Benzo(g,h,i)perylene		5	0.1	
Benzo(k)fluoranthene		10	2	
Bis 2-(1-Chloroethoxy) methane		5		
Bis(2-chloroethyl) ether	10	1		
Bis(2-Chloroisopropyl) ether	10	2		
Bis(2-Ethylhexyl) phthalate	10	5		
Butyl benzyl phthalate	10	10		
Chrysene		10	5	
di-n-Butyl phthalate		10		
di-n-Octyl phthalate		10		
Dibenzo(a,h)-anthracene		10	0.1	
Diethyl phthalate	10	2		
Dimethyl phthalate	10	2		
Fluoranthene	10	1	0.05	
Fluorene		10	0.1	
Hexachloro-cyclopentadiene	5	5		
Hexachlorobenzene	5	1		
Hexachlorobutadiene	5	1		

Table 2b - SEMI-VOLATILE SUBSTANCES*	GC	GCMS	LC	COLOR
Hexachloroethane	5	1		
Indeno(1,2,3,cd)-pyrene		10	0.05	
Isophorone	10	1		
N-Nitroso diphenyl amine	10	1		
N-Nitroso-dimethyl amine	10	5		
N-Nitroso -di n-propyl amine	10	5		
Naphthalene	10	1	0.2	
Nitrobenzene	10	1		
Pentachlorophenol	1	5		
Phenanthrene		5	0.05	
Phenol **	1	1		50
Pyrene		10	0.05	

*With the exception of phenol by colorimetric technique, the normal method-specific factor for these substances is 1,000; therefore, the lowest standard concentration in the calibration curve is equal to the above ML value for each substance multiplied by 1,000.

**Phenol by colorimetric technique has a factor of 1.

Table H-3 Inorganics

Table 2c - INORGANICS*	FAA	GFAA	ICP	ICPMS	SPGFAA	HYDRIDE	CVAA	COLOR	DCP
Antimony	10	5	50	0.5	5	0.5			1,000
Arsenic		2	10	2	2	1		20	1,000
Beryllium	20	0.5	2	0.5	1				1,000
Cadmium	10	0.5	10	0.25	0.5				1,000
Chromium (total)	50	2	10	0.5	1				1,000
Chromium VI	5							10	
Copper	25	5	10	0.5	2				1,000
Cyanide								5	
Lead	20	5	5	0.5	2				10,000
Mercury				0.5			0.2		
Nickel	50	5	20	1	5				1,000
Selenium		5	10	2	5	1			1,000
Silver	10	1	10	0.25	2				1,000
Thallium	10	2	10	1	5				1,000
Zinc	20		20	1	10				1,000

*The normal method-specific factor for these substances is 1; therefore, the lowest standard concentration in the calibration curve is equal to the above ML value for each substance.

Table H-4 Pesticides and PCBs

Table 2d - PESTICIDES - PCBs*	GC
4,4'-DDD	0.05

4,4'-DDE	0.05
4,4'-DDT	0.01
a-Endosulfan	0.02
alpha-BHC	0.01
Aldrin	0.005
b-Endosulfan	0.01
Beta-BHC	0.005
Chlordane	0.1
Delta-BHC	0.005
Dieldrin	0.01
Endosulfan Sulfate	0.05
Endrin	0.01
Endrin Aldehyde	0.01
Heptachlor	0.01
Heptachlor Epoxide	0.01
Gamma-BHC (Lindane)	0.02
PCB 1016	0.5
PCB 1221	0.5
PCB 1232	0.5
PCB 1242	0.5
PCB 1248	0.5
PCB 1254	0.5
PCB 1260	0.5
Toxaphene	0.5

*The normal method-specific factor for these substances is 100; therefore, the lowest standard concentration in the calibration curve is equal to the above ML value for each substance multiplied by 100.

Techniques:

GC - Gas Chromatography

GCMS - Gas Chromatography/Mass Spectrometry

HRGCMS - High Resolution Gas Chromatography/Mass Spectrometry (i.e., EPA 1613, 1624, or 1625)

LC - High Pressure Liquid Chromatography

FAA - Flame Atomic Absorption

GFAA - Graphite Furnace Atomic Absorption

HYDRIDE - Gaseous Hydride Atomic Absorption

CVAA - Cold Vapor Atomic Absorption

ICP - Inductively Coupled Plasma

ICPMS - Inductively Coupled Plasma/Mass Spectrometry

SPGFAA - Stabilized Platform Graphite Furnace Atomic Absorption (i.e., EPA 200.9)

DCP - Direct Current Plasma

COLOR - Colorimetric

ATTACHMENT I

ATTACHMENT I – COVER SHEET

Date _____

California Regional Water Quality Control Board
Lahontan Region
2501 Lake Tahoe Boulevard
South Lake Tahoe, CA 96150

Facility Name: _____

Address: _____

Contact Person: _____

Job Title: _____

Phone: _____

Email: _____

WDR/NPDES Order Number: _____

WDID Number: _____

Type of Report (circle one): Monthly Quarterly Semi-Annual Annual Other

Month(s) JAN FEB MAR APR MAY JUN
(circle applicable month(s)*) JUL AUG SEPT OCT NOV DEC

***Annual Reports** Year _____
(circle the first month of the reporting period)

Violation(s)? (Please check one): _____ NO YES*

***If YES is marked complete a-g (Attach Additional information as necessary)**

a) Brief Description of Violation: _____

b) Section(s) of WDRs/NPDES Permit Violated: _____

c) Reported Value(s) or Volume: _____

d) WDRs/NPDES Limit/Condition: _____

e) Date(s) and Duration of Violation(s): _____

f) Explanation of Cause(s): _____

g) Corrective Action(s) (Specify actions taken and a schedule for actions to be taken)

I certify under penalty of law that this document and all attachments were prepared under my direction or supervision following a system designed to ensure that qualified personnel properly gather and evaluate the information submitted. Based on my knowledge of the person(s) who manage the system, or those directly responsible for data gathering, the information submitted is, to the best of my knowledge and belief, true, accurate, and complete. I am aware that there are significant penalties for submitting false information, including the possibility of fine and imprisonment.

If you have any questions or require additional information, please contact _____ at the number provided above.

Signature: _____

Name: _____

Title: _____