

Los Angeles Regional Water Quality Control Board

March 12, 2014

**CERTIFIED MAIL NO. 7012 3460 0000 2166 0163
RETURN RECEIPT REQUESTED**

Mr. Michael A. Palmer
Montrose Chemical Corporation of California
600 Ericksen Avenue NE, Suite 380
Bainbridge Island, WA 98110

REVISION OF COVERAGE UNDER GENERAL NATIONAL POLLUTANT DISCHARGE ELIMINATION SYSTEM AND WASTE DISCHARGE REQUIREMENTS—MONTROSE CHEMICAL CORPORATION OF CALIFORNIA, MONTROSE SUPERFUND SITE, 20201 SOUTH NORMANDIE AVENUE, LOS ANGELES, CALIFORNIA (NPDES NO. CAG994004, CI-8819)

Dear Mr. Palmer:

We have received your consultant's (AECOM) letter dated March 6, 2014, for the above referenced project. AECOM requested a revision of your enrollment under the General NPDES Permit CAG994004 Order No. R4-2013-0095 and add one new outfall to support hydraulic testing of one additional extraction well associated with the construction of the groundwater remediation system at the subject site. The water from the 13 existing discharge points (M-001 to M-013) and the proposed discharge point (M-014) flows into the Dominguez Channel.

Based on the information provided, we have no objections to incorporating the proposed new outfall location to the project. The proposed groundwater discharge meets the conditions to be regulated under Order No. R4-2013-0095, *General National Pollutant Discharge Elimination System and Waste Discharge Requirements for Discharges of Groundwater from Construction and Project Dewatering to Surface Waters in Coastal Watersheds of Los Angeles and Ventura Counties*, adopted by this Board on June 6, 2013.

Enclosed are your Waste Discharge Requirements, which also serve as your NPDES permit, consisting of Order No. R4-2013-0095 and Monitoring and Reporting Program No. CI-8819. The discharge limitations in Part V.A.1. Tables 1, 2, 3 and 13 of the Effluent Limitations Order No. R4-2013-0095 for the specific constituents listed in Table 1 with the enclosed Fact Sheet are applicable to your discharge. The groundwater discharge from the project flows into Dominguez Channel therefore, the mineral limitations in Attachment B of the Order are not applicable to your discharge. In addition, the Dominguez Channel metals Total Maximum Daily Load (TMDL) effluent limitations are applicable to your discharge. All parts of the Order applies, including but not limited to narrative effluent and receiving water limitations. Prior to starting discharge, a representative sample of the effluent shall be obtained and analyzed to determine compliance with the discharge limitations.

CHARLES STRINGER, CHAIR | SAMUEL UNGER, EXECUTIVE OFFICER

320 West 4th St., Suite 200, Los Angeles, CA 90013 | www.waterboards.ca.gov/losangeles

The Monitoring and Reporting Program requires you to implement the monitoring program on the effective date of coverage under this permit. All monitoring reports should be sent to the Regional Board, electronically by e-mail to losangeles@waterboards.ca.gov. When submitting monitoring or technical reports to the Regional Board per these requirements, please include a reference to "Compliance File No. CI-8819 and NPDES No. CAG994004", which will assure that the reports are directed to the appropriate file and staff. Also, please do not combine other reports with your monitoring reports. Submit each type of report as a separate document.

The Regional Board is implementing a paperless office system to reduce paper use, increase efficiency and provide a more effective way for our staff, the public and interested parties to view water quality documents. Therefore, please convert all regulatory documents, submissions, data and correspondence that you would normally submit to us as hard copies to a searchable Portable Document Format (PDF). Documents that are less than 10 MB should be emailed to losangeles@waterboards.ca.gov. Documents that are 10 MB or larger should be transferred to a disk and mailed to the address listed above. If you need additional information regarding electronic submittal of documents please visit the Regional Board's website listed above and navigate to Paperless Office.

To avoid future annual fees, please submit written request for termination of your enrollment under the general permit in a separate letter, when the project has been completed and the permit is no longer needed.

We are sending a copy of Order No. R4-2013-0095 only to the applicant. For those on the mailing list, please refer to the Board Order previously sent to you. A copy of the Order will be furnished to anyone who requests it, or it can be obtained at our web site address: [http://www.waterboards.ca.gov/losangeles/board decisions/adopted orders/](http://www.waterboards.ca.gov/losangeles/board%20decisions/adopted%20orders/).

If you have any questions, please contact Alex Carlos at 213-576-6726.

Sincerely,



Samuel Unger, P.E.
Executive Officer

Enclosures:

Order No. R4-2013-0095
Monitoring and Reporting Program No. CI-8819
Fact Sheet

cc: Environmental Protection Agency, Region 9, Permit Section (WTR-5)
State Water Resources Control Board, npdes-wastewater@waterboards.ca.gov
U.S. Army Corps of Engineers
U.S. Fish and Wildlife Services, Division of Ecological Services
NOAA, National Marine Fisheries Service
California Department of Fish and Game, Marine Resources, Region 5
Los Angeles County, Department of Public Works, Environmental Programs Division
Los Angeles County, Department of Public Works, Flood Maintenance Division
City of West Hollywood, Department of Public Works
Jae Kim, Tetra Tech
Brian Dean, AECOM
Katharine CarrGreen, AECOM

STATE OF CALIFORNIA
CALIFORNIA REGIONAL WATER QUALITY CONTROL BOARD
LOS ANGELES REGION
320 West 4th Street, Suite 200, Los Angeles, California 90013

**REVISED FACT SHEET
WASTE DISCHARGE REQUIREMENTS
FOR**

**MONTROSE CHEMICAL CORPORATION OF CALIFORNIA
(MONTROSE SUPERFUND SITE)**

**ORDER NO. R4-2013-0095
NPDES NO. CAG994004, SERIES NO. 040
CI-8819**

FACILITY ADDRESS

20201 South Normandie Avenue
Los Angeles, CA 90501

FACILITY MAILING ADDRESS

600 Ericksen Avenue NE, Suite 380
Bainbridge Island, WA 98110

PROJECT DESCRIPTION:

Montrose Chemical Corporation of California (Discharger) is constructing a 700 gallon per minute groundwater remediation system which includes pump and treat with discharge of treated effluent via injection wells in the vicinity of the former Montrose facility located at 20201 South Normandie Avenue, Los Angeles. During the construction, the Discharger will install, develop and conduct hydraulic testing of extraction and injection wells. The groundwater generated during the construction is treated using solid filtration units to remove particulates and a liquid phase granular activated carbon adsorption system to remove organic contaminants. If needed, additional equipment may be utilized for metals treatment prior to discharge of the treated groundwater to the storm drains. Figure 1 shows the schematic of the treatment process. The discharger was permitted to discharge treated groundwater to the storm drain system at 13 discharge points (M-001 to M-013). On March 6, 2014, the Discharger requested a revision of the enrollment under the general NPDES permit to cover discharges from the well installation and hydraulic testing of one additional extraction well and add one discharge point location, M-014 (Outfall 14). This Fact Sheet is being revised to include the coverage under the general NPDES Permit for discharge of treated groundwater from one additional discharge point M-014 (Outfall 14). This water will flow into the Dominguez Channel. Figure 3 shows the location of existing (M-001 to M-013) and proposed (M-014) discharge points.

VOLUME AND DESCRIPTION OF DISCHARGE:

Up to 504,000 gallons per day (gpd) of treated groundwater will be discharged to the storm drain system at 14 Discharge Points, which flows into Dominguez Channel, a water of the United States. The site location map is shown in Figure 2.

Discharge Point	Latitude	Longitude
M-001 (Outfall 1A)	33°50'30"	-118°17'58"
M-002 (Outfall 2A)	33°50'23"	-118°17'41"
M-003 (Outfall 3A)	33°50'04"	-118°17'25"
M-004 (Outfall 4)	33°50'08"	-118°17'26"
M-005 (Outfall 5)	33°50'20"	-118°17'28"
M-006 (Outfall 6)	33°50'30"	-118°17'58"
M-007 (Outfall 7)	33°50'51"	-118°18'32"
M-008 (Outfall 8)	33°50'50"	-118°17'25"
M-009 (Outfall 9)	33°50'31"	-118°17'23"
M-010 (Outfall 10)	33°50'15"	-118°17'35"
M-011 (Outfall 11)	33°50'31"	-118°17'51"
M-012 (Outfall 12)	33°50'43"	-118°17'42"
M-013 (Outfall 13)	33°50'39"	-118°17'77"
M-014 (Outfall 14)	33°50'44"	-118°17'53"

APPLICABLE EFFLUENT LIMITATIONS

Based on the information provided in the NPDES Application Supplemental Requirements the Regional Board has determined that the constituents listed in Table 1 below, show reasonable potential to exist in the discharge. Therefore, effluent limitations contained in Part V. Tables 1, 2, 3 and 13 of Order No. R4-2013-0095 are applicable to the discharge, as listed in Table 1 below. The discharge flows to the Dominguez Channel therefore, the mineral effluent limitations in Attachment B of Order No. R4-2013-0095 are not applicable to the discharge. In addition, the Dominguez Channel metals Total Maximum Daily Load (TMDL) effluent limitations are applicable to your discharge. The Discharger must comply with all other parts of the Order, including, but not limited, to narrative effluent and receiving water limitations.

Table 1: The Discharger is required to comply with these effluent limitations during its enrollment under Order No. R4-2013-0095.

Constituents	Units	Discharge Limitations	
		Daily Maximum	Monthly Average
Total Suspended Solids	mg/L	75	50
Turbidity	NTU	150	50
BOD ₅ 20°C	mg/L	30	20
Oil and Grease	mg/L	15	10
Settleable Solids	ml/L	0.3	0.1

Constituents	Units	Discharge Limitations	
		Daily Maximum	Monthly Average
Sulfides	mg/L	1.0	---
Phenols	mg/L	1.0	---
Residual Chlorine	mg/L	0.1	---
Methylene Blue Active Substances (MBAS)	mg/L	0.5	---
Volatile organic compounds			
1,2-Dichloroethane	µg/L	0.5	---
1,4-Dichlorobenzene	µg/L	5.0	---
Benzene	µg/L	1.0	---
Tetrachloroethylene	µg/L	5.0	---
Trichloroethylene	µg/L	5.0	---
Metals			
Nickel	mg/L	100	100
Pesticides			
alpha-BHC	µg/L	0.026	0.013
beta-BHC	µg/L	0.092	0.046
Miscellaneous			
Total petroleum hydrocarbons	µg/L	100	---
Dominguez Channel and Greater Los Angeles and Long Beach Harbor waters Toxic Pollutants TMDL in Water Column			
Copper	µg/L (water, unfiltered)	9.7	4.8
Lead	µg/L (water, unfiltered)	43	21
Zinc	µg/L	70	35

FREQUENCY OF DISCHARGE:

The discharge of groundwater is intermittent and as on need basis.

REUSE OF WATER:

The discharger submitted a feasibility study to the Regional Board analyzing the water conservation re-use, and/or alternative disposal options for the discharge. Although a small portion of the treated groundwater may be transported to an off-site facility for disposal, it is not economically feasible to transport all groundwater generated during well development and testing for off-site disposal. Due to the large volume of groundwater that will be generated, it is also not feasible to discharge the treated groundwater to the sanitary sewer system. There are no other feasible reuse options for this discharge including on-site irrigation. Therefore, the majority of the treated groundwater from the development and well testing during the construction will be discharged to a nearby storm drain that discharges to the Dominguez Channel in compliance with the requirements of the attached Order R4-2013-0095.

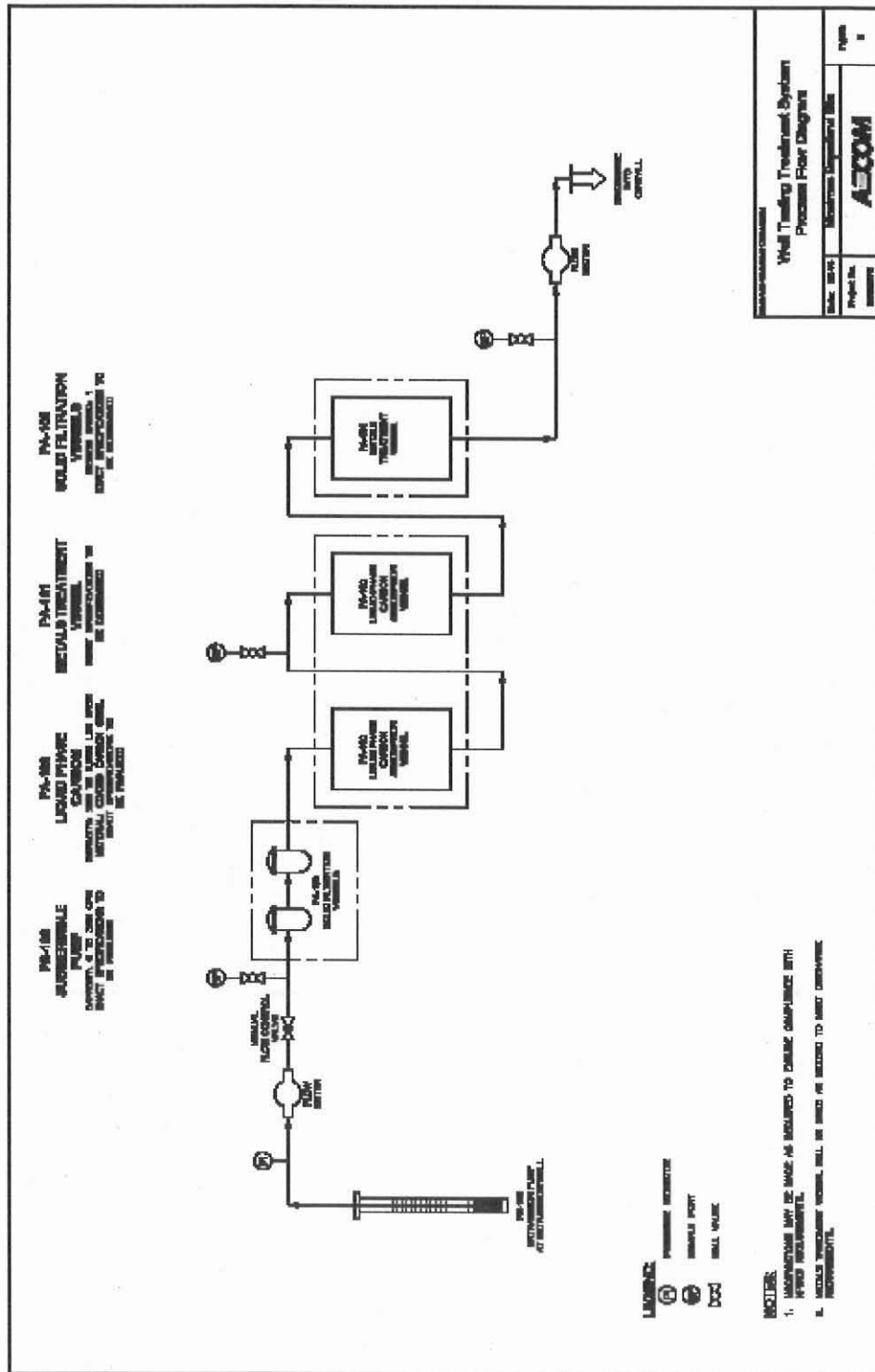

Figure 1. Schematic of treatment process

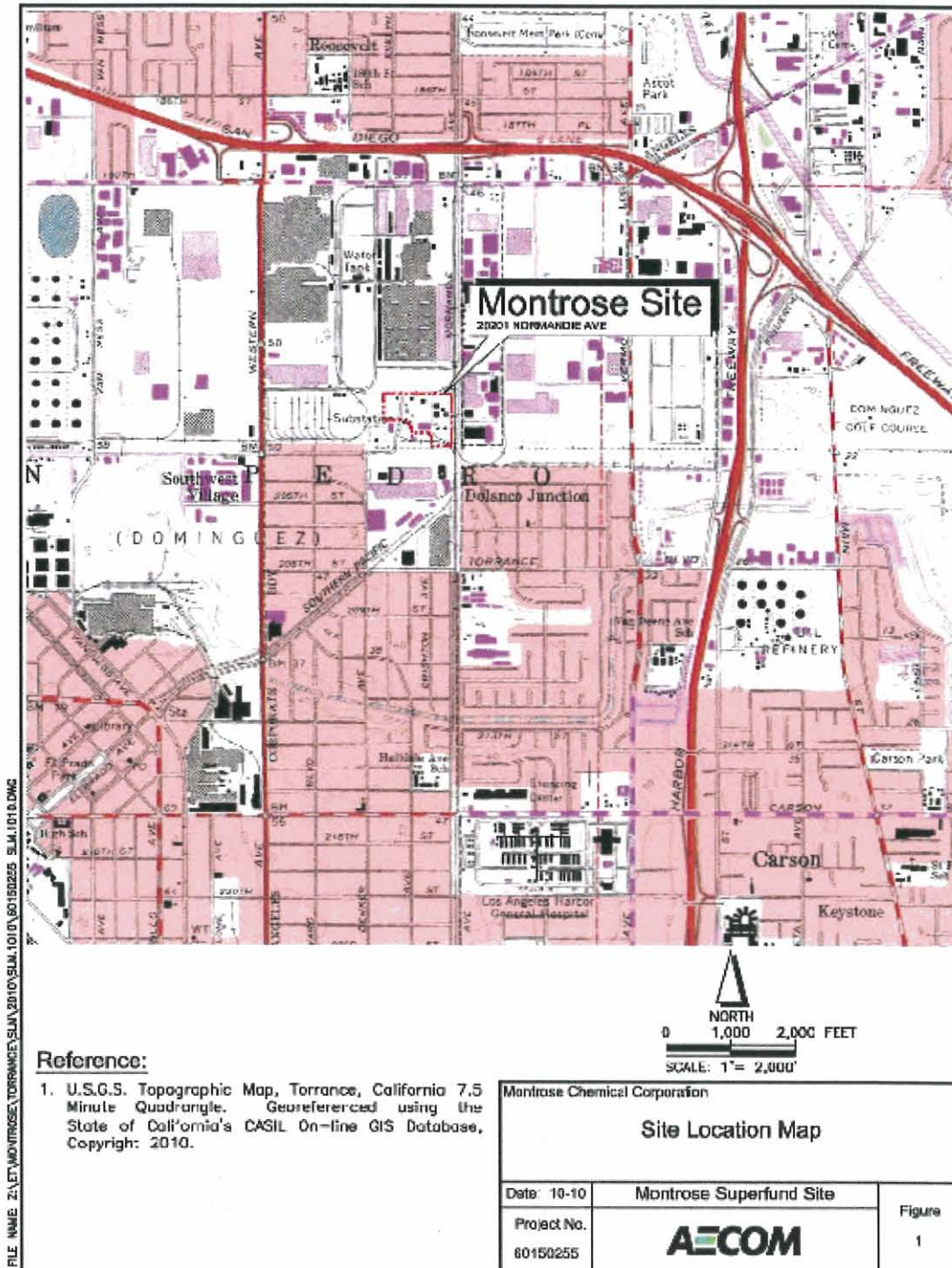

Figure 2. Site map

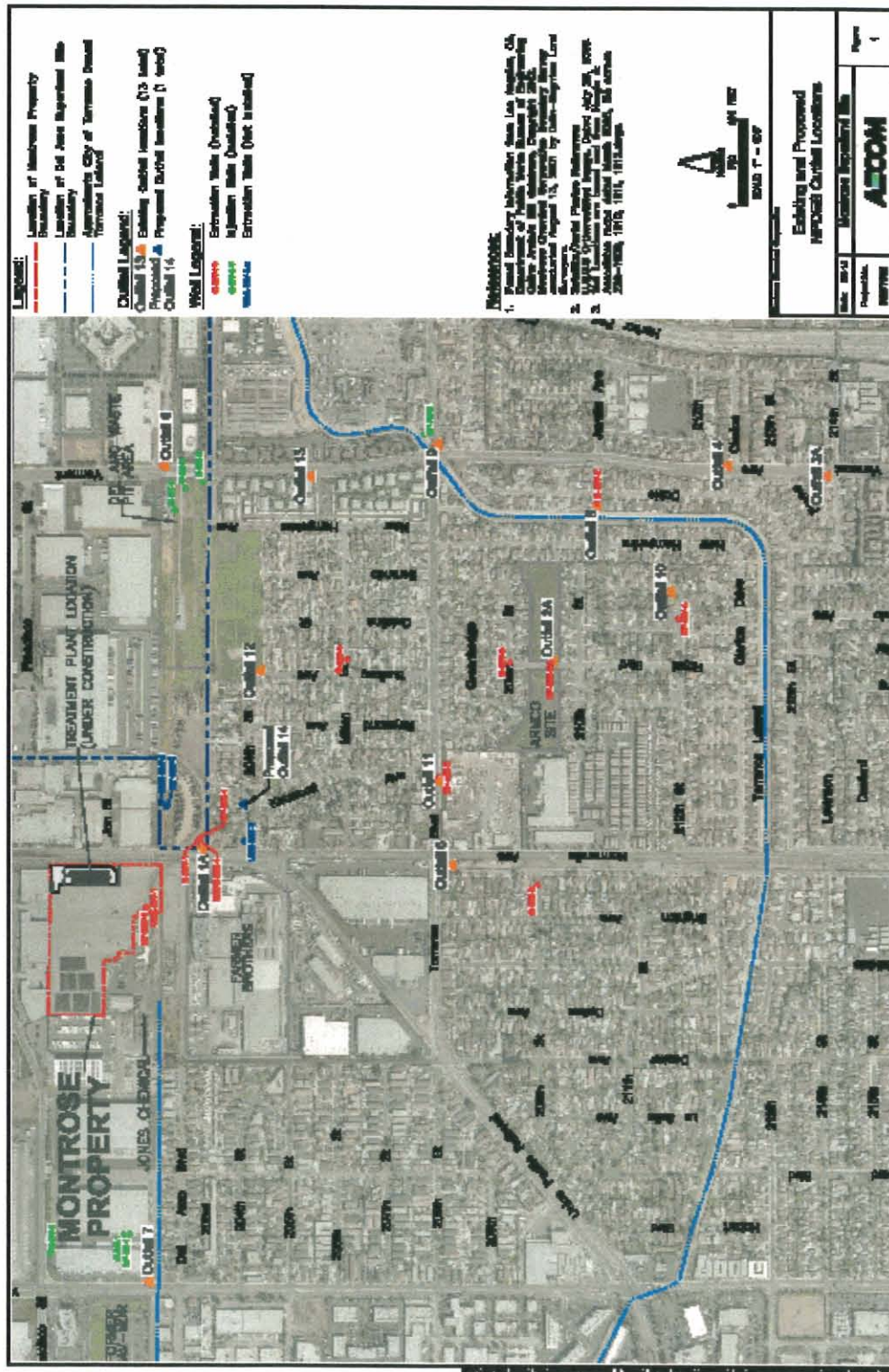

Figure 3. Existing and proposed NPDES Discharge Points

STATE OF CALIFORNIA
CALIFORNIA REGIONAL WATER QUALITY CONTROL BOARD
LOS ANGELES REGION

MONITORING AND REPORTING PROGRAM NO. CI-8819

FOR
DISCHARGES OF GROUNDWATER FROM CONSTRUCTION AND PROJECT DEWATERING
TO SURFACE WATERS
IN
COASTAL WATERSHEDS OF LOS ANGELES AND VENTURA COUNTIES
(GENERAL NPDES PERMIT NO. CAG994004, SERIES NO.040)

This Order was adopted by the Regional Water Board on:	June 6, 2013
Enrollment to this Order shall become effective on:	March 12, 2014
This Order shall expire on:	July 6, 2018
The U.S. Environmental Protection Agency and the Regional Water Quality Control Board have classified discharges covered under this General Permit as a minor discharge.	

Ordered by: Samuel Unger
Samuel Unger, P.E.
Executive Officer

Date: March 12, 2014

Table of Contents

I.	General Monitoring Provisions	3
II.	Monitoring Locations	6
III.	Influent Monitoring requirements.....	6
IV.	Effluent Monitoring Requirements	7
V.	Whole Effluent Toxicity Testing Requirements.....	8
	A. Acute Toxicity Effluent Monitoring Program.....	8
	B. Reporting.....	9
VI.	Land Discharge Monitoring Requirements (Not Applicable)	9
VII.	Reclamation Monitoring requirements (Not Applicable).....	9
VIII.	Receiving water monitoring requirements – Surface water and groundwater (Not Applicable).....	10
IX.	Other monitoring requirements (Not Applicable)	10
X.	Reporting Requirements.....	10
	A. General Monitoring and Reportign Requirements.....	10
	B. Self Monitoring Reports.....	10
	C. Discharge Monitoring Reports (DMRs) (Not Applicable)....	12
	D. Other Reports (Not Applicable).....	12
	E. Notification.....	12
XI.	MONITORING FREQUENCIES adjustment.....	13

Monitoring and Reporting Program (MRP)

40 CFR section 122.48 requires that all NPDES permits specify monitoring and reporting requirements. Sections 13267 and 13383 of the CWC also authorize the Regional Water Board to require technical and monitoring reports. This MRP establishes monitoring and reporting requirements which implement the federal and California regulations.

I. GENERAL MONITORING PROVISIONS

- A. An effluent sampling station shall be established for Discharge Points M-001 to M-013 and shall be located where representative samples of that effluent can be obtained.
- B. This Regional Water Board shall be notified in writing of any change in the sampling stations once established or in the methods for determining the quantities of pollutants in the individual waste streams.
- C. Pollutants shall be analyzed using the analytical methods described in 40 CFR section Sections 136.3, 136.4, and 136.5 (revised March 12, 2007); or, where no methods are specified for a given pollutant, by methods approved by this Regional Water Board or the State Water Board.
- D. For any analyses performed for which no procedure is specified in the USEPA guidelines or in the MRP, the constituent or parameter analyzed and the method or procedure used must be specified in the monitoring report.
- E. Laboratories analyzing effluent samples and receiving water samples shall be certified by the California Department of Health Services Environmental Laboratory Approval Program (ELAP) or approved by the Executive Officer and must include QA/QC data in their reports. A copy of the laboratory certification shall be provided each time a new certification and/or renewal of the certification is obtained from ELAP.
- F. Each monitoring report must affirm in writing that "all analyses were conducted at a laboratory certified for such analyses by the Department of Health Services or approved by the Executive Officer and in accordance with current USEPA guideline procedures or as specified in this Monitoring and Reporting Program".
- G. The monitoring reports shall specify the analytical method, the Method Detection Limit (MDL), and the State Water Board Minimum Level (ML) for each pollutant. For the purpose of reporting compliance with numerical limitations, performance goals, and receiving water limitations, analytical data shall be reported by one of the following methods, as appropriate:
 1. An actual numerical value for sample results greater than or equal to the ML; or
 2. "Detected, but Not Quantified (DNQ)" if results are greater than or equal to the laboratory's MDL but less than the ML; or
 3. "Not Detected (ND)" for sample results less than the laboratory's MDL with the MDL indicated for the analytical method used.

Analytical data reported as "less than" for the purpose of reporting compliance with permit limitations shall be the same or lower than the permit limit(s) established for the given parameter.

Current MLs, which are listed in Appendix A, are those published by the State Water Resources Control Board in the *Policy for the Implementation of Toxics Standards for Inland Surface Waters, Enclosed Bays, and Estuaries of California*, March 2, 2000.

- H. Where possible, the MLs employed for effluent analyses shall be lower than the permit limitations established for a given parameter. If the ML value is not below the effluent limitation, then the lowest ML value and its associated analytical method shall be selected for compliance purposes. At least once a year, the Discharger shall submit a list of the analytical methods employed for each test and associated laboratory QA/QC procedures.

The Regional Water Board, in consultation with the State Water Board Quality Assurance Program, shall establish a ML that is not contained in Appendix A to be included in the Discharger's permit in any of the following situations:

1. When the pollutant under consideration is not included in Appendix A;
 2. When the Discharger and Regional Water Board agree to include in the permit a test method that is more sensitive than that specified in 40 CFR Part 136 (revised May 14, 1999);
 3. When the Discharger agrees to use an ML that is lower than that listed in Appendix A;
 4. When the Discharger demonstrates that the calibration standard matrix is sufficiently different from that used to establish the ML in Appendix A, and proposes an appropriate ML for their matrix; or,
 5. When the Discharger uses a method whose quantification practices are not consistent with the definition of an ML. Examples of such methods are the USEPA-approved method 1613 for dioxins and furans, method 1624 for volatile organic substances, and method 1625 for semi-volatile organic substances. In such cases, the Discharger, the Regional Water Board, and the State Water Board shall agree on a lowest quantifiable limit and that limit will substitute for the ML for reporting and compliance determination purposes.
- I. Water/wastewater samples must be analyzed within allowable holding time limits as specified in 40 CFR section 136.3. All QA/QC items must be run on the same dates the samples were actually analyzed, and the results shall be reported in the Regional Water Board format, when it becomes available, and submitted with the laboratory reports. Proper chain of custody procedures must be followed, and a copy of the chain of custody shall be submitted with the report.
- J. All analyses shall be accompanied by the chain of custody, including but not limited to data and time of sampling, sample identification, and name of person who performed sampling, date of analysis, name of person who performed analysis, QA/QC data, method detection limits, analytical methods, copy of laboratory certification, and a perjury statement executed by the person responsible for the laboratory.

- K. The Discharger shall calibrate and perform maintenance procedures on all monitoring instruments and to insure accuracy of measurements, or shall insure that both equipment activities will be conducted.
- L. The Discharger shall have, and implement, an acceptable written quality assurance (QA) plan for laboratory analyses. The annual monitoring report required in Section X.b.3. of this MRP shall also summarize the QA activities for the previous year. Duplicate chemical analyses must be conducted on a minimum of ten percent (10%) of the samples, or at least one sample per sampling period, whichever is greater. A similar frequency shall be maintained for analyzing spiked samples.
- M. When requested by the Regional Water Board or USEPA, the Discharger will participate in the NPDES discharge monitoring report QA performance study. The Discharger must have a success rate equal to or greater than 80%.
- N. For parameters that both monthly average and daily maximum limitations are specified and the monitoring frequency is less than four times a month, the following shall apply. If an analytical result is greater than the monthly average limitation, the Discharger shall collect four additional samples at approximately equal intervals until compliance with the monthly average limitation has been demonstrated. All five analytical results shall be reported in the monitoring report for that month, or 45 days after results for the additional samples were received, whichever is later. In the event of noncompliance with a monthly average effluent limitation, the sampling frequency for that constituent shall be increased to weekly and shall continue at this level until compliance with the monthly average effluent limitation has been demonstrated. The Discharger shall provide for the approval of the Executive Officer a program to ensure future compliance with the monthly average limitation.
- O. In the event wastes are transported to a different disposal site during the report period, the following shall be reported in the monitoring report:
 - 1. Types of wastes and quantity of each type;
 - 2. Name and address for each hauler of wastes (or method of transport if other than by hauling); and
 - 3. Location of the final point(s) of disposal for each type of waste.

If no wastes are transported off-site during the reporting period, a statement to that effect shall be submitted.

- P. Each monitoring report shall state whether or not there was any change in the discharge as described in the Order during the reporting period.
- Q. All monitoring reports shall include the discharge limitations in the Order, tabulated analytical data, the chain of custody form, and the laboratory report (including but not limited to date and time of sampling, date of analyses, method of analysis and detection limits).
- R. Each monitoring report shall contain a separate section titled "Summary of Non-compliance" which discusses the compliance record and corrective action taken or planned that may be needed to bring the discharge into full compliance with waste discharge requirements. This section shall clearly list all non-compliance with waste discharge requirements, as well as all excursions of effluent limitations.

- S. Before commencing a new discharge, a representative sample of the effluent shall be collected and analyzed for toxicity and for all the constituents listed in Fact Sheet, and the test results must meet all applicable limitations of Order No. R4-2013-0095.
- T. In the In the event of presence of oil sheen, debris, and/or other objectionable materials or odors, discharge shall not commence until compliance with the requirements is demonstrated. All visual observations shall be included in the monitoring report.
- U. If monitoring results indicate an exceedance of a limit contained in Order R4-2013-0095, the discharge shall be terminated and shall only be resumed after remedial measures have been implemented and full compliance with the requirements has been ascertained.
- V. In addition, as applicable, following an effluent limit exceedance, the Discharger shall implement the following accelerated monitoring program:
 - a. Monthly monitoring shall be increased to weekly monitoring,
 - b. Quarterly monitoring shall be increased to monthly monitoring , and
 - c. Semi-annually monitoring shall be increased to quarterly.
 - d. Annual monitoring shall be increased to semi-annually.

If three consecutive accelerated monitoring events demonstrate full compliance with effluent limits, the Discharger may return to the regular monitoring frequency, with the approval of the Executive Officer of the Regional Water Board.

II. MONITORING LOCATIONS

The Discharger shall establish the following monitoring locations to demonstrate compliance with the effluent limitations, discharge specifications, and other requirements in this Order:

Table 1. Monitoring Points Information

Discharge Point Name	Monitoring Location Name	Monitoring Location Description
Discharge Point 1	M-001	Treated effluent, after treatment and before contact with the receiving water and/or dilution by any other water or waste.
Discharge Point 2	M-002	If more than one discharge point is authorized under the General Permit, compliance monitoring locations shall be named M-002, M-003, etc. and shall be located so as to allow collection of treated effluent after treatment and before contact with receiving water and/or dilution by any other water or waste.

III. INFLUENT MONITORING REQUIREMENTS (NOT APPLICABLE)

IV. EFFLUENT MONITORING REQUIREMENTS

A. The Discharger shall monitor the effluent at Discharge Points M-001 to M-014. (The representative effluent samples shall be collected after all treatment processes (if any) while discharging and before contact or mixing with receiving water or other waters and/or dilution with any other water or waste).

Table 2. Monitoring Constituents

Parameter	Units	Sample Type	Minimum Sampling Frequency	Required Analytical Test Method
Flow	gal/day	totalizer	Continuously ²	1
pH	pH units	grab	monthly	1
Temperature	°F	grab	monthly	1
Total Suspended Solids	mg/L	grab	monthly	1
Turbidity	NTU	grab	monthly	1
BOD ₅ 20°C	mg/L	grab	monthly	1
Oil and Grease	mg/L	grab	monthly	1
Settleable Solids	ml/L	grab	monthly	1
Sulfides	mg/L	grab	monthly	1
Phenols	mg/L	grab	monthly	1
Residual Chlorine	mg/L	grab	monthly	1
Methylene Blue Active Substances (MBAS)	mg/L	grab	monthly	1
1,2-Dichloroethane	µg/L	grab	monthly	1
1,4-Dichlorobenzene	µg/L	grab	monthly	1
Benzene	µg/L	grab	monthly	1
Tetrachloroethylene	µg/L	grab	monthly	1
Trichloroethylene	µg/L	grab	monthly	1
Nickel	µg/L	grab	monthly	1
alpha-BHC	µg/L	grab	monthly	1
beta-BHC	µg/L	grab	monthly	1
Total petroleum hydrocarbons	µg/L	grab	monthly	1
Acute Toxicity	% survival	grab	annually	1
Dominguez Channel Metals TMDL				
Copper, TR	µg/L	grab	quarterly	1
Lead, TR	µg/L	grab	quarterly	1
Zinc, TR	µg/L	grab	quarterly	1

Notes: 1: Pollutants shall be analyzed using the analytical methods described in 40 CFR Part 136; for priority pollutants the

Parameter	Units	Sample Type	Minimum Sampling Frequency	Required Analytical Test Method
<p>methods must meet the lowest minimum levels (MLs) specified in Attachment 4 of the SIP (and included as Appendix A of this Order), where no methods are specified for a given pollutant, by methods approved by this Regional Water Board or the State Water Board.</p> <p>2: Record the monthly total flow and report the calculated daily average flow and monthly flow in the quarterly and annual reports, as appropriate.</p>				

V. WHOLE EFFLUENT TOXICITY TESTING REQUIREMENTS

The MRP requires an annual test of Acute Toxicity, which measures primarily lethal effects that occur over a 96-hour period. Acute toxicity shall be recorded in percent survival measured in undiluted (100%) effluent.

A. Acute Toxicity Effluent Monitoring Program

1. The Discharger shall conduct acute toxicity tests on effluent samples (e.g., grab samples) by methods specified in 40 CFR Part 136 which cites USEPA's *Methods for Measuring the Acute Toxicity of Effluents and Receiving Waters to Freshwater and Marine Organisms*, Fifth Edition, October 2002, USEPA, Office of Water, Washington D.C. (EPA/821-R-02-012) or a more recent edition to ensure compliance in 100 % effluent.
2. The fathead minnow, *Pimephales promelas*, shall be used as the test species for discharge into freshwater and the topsmelt, *Atherinops affinis*, shall be used as the test species for discharge into coastal water. If the salinity of the receiving water is between 1 to 32 parts per thousand (ppt), the Discharger have the option of using the inland silverside, *Menidia beryllina*, instead of the topsmelt. The method for topsmelt (Larval Survival and Growth Test Method 1006.0) is found in USEPA's *Short-term Methods for Estimating the Chronic Toxicity of Effluent and Receiving Waters to West Coast Marine and Estuarine Organisms*, First Edition, August 1995 (EPA/600/R-95/136), or a more recent edition. The method for *Pimephales promelas* is found in USEPA's *Acute Toxicity Test Method 2000.0* and method for *Menidia beryllina* is found in USEPA's *Acute Toxicity Test Method 2006.0*, or a more recent edition.
3. In lieu of conducting the standard acute toxicity testing with the fathead minnow, the Discharger may elect to report the results or endpoint from the first 48 hours of the chronic toxicity test as the results of the acute toxicity test.
4. Accelerated Toxicity Monitoring: If the results of the toxicity test yield a survival of less than 90%, then the frequency of analyses shall increase to monthly until at least three test results have been obtained and full compliance with effluent limitations has been demonstrated, after which the frequency of analyses shall revert to annually. Results of toxicity tests shall be included in the first monitoring report following sampling.
5. Effluent samples shall be collected after all treatment processes and before discharge to the receiving water.

B. Reporting

1. The Discharger shall submit a full report of the toxicity test results, including any accelerated testing conducted during the month as required by this General Permit. Test results shall be reported as % survival for acute toxicity test results with the self monitoring reports (SMR) for the month in which the test is conducted.
2. If an initial investigation indicates the source of toxicity and accelerated testing is unnecessary, then those results also shall be submitted with the SMR for the period in which the investigation occurred.
 - a. The full report shall be submitted on or before the end of the month in which the SMR is submitted.
 - b. The full report shall consist of (1) the results; (2) the dates of sample collection and initiation of each toxicity test; (3) the acute toxicity average limit.
3. Test results for toxicity tests shall be reported according to the appropriate manual chapter on Report Preparation and shall be attached to the SMR. Routine reporting shall include, at a minimum, as applicable, for each test:
 - a. Sample date(s);
 - b. Test initiation date;
 - c. Test species;
 - d. End point values for each dilution (e.g., number of young, growth rate, percent survival);
 - e. Any applicable charts; and
 - f. Available water quality measurements for each test (e.g., pH, D.O., temperature, conductivity, hardness, salinity, ammonia).
4. The Discharger shall provide a compliance summary, which includes a summary table of toxicity data from all samples collected during that year.

The Discharger shall notify this Regional Water Board by calling Alex Carlos at (213) 576-6726 and by email to acarlos@waterboards.ca.gov of any toxicity exceedance of the limit or trigger within 24 hours of receipt of the results followed by a written report within 14 calendar days of receipt of the results. The verbal or electronic notification shall include the exceedance and the plan the Discharger has taken or will take to investigate and correct the cause(s) of toxicity. It may also include a status report on any actions required by the permit, with a schedule for actions not yet completed. If no actions have been taken, the reasons shall be given.

VI. LAND DISCHARGE MONITORING REQUIREMENTS (NOT APPLICABLE)

VII. RECLAMATION MONITORING REQUIREMENTS (NOT APPLICABLE)

VIII. RECEIVING WATER MONITORING REQUIREMENTS – SURFACE WATER AND GROUNDWATER (NOT APPLICABLE)

IX. OTHER MONITORING REQUIREMENTS (NOT APPLICABLE)

X. REPORTING REQUIREMENTS

A. General Monitoring and Reporting Requirements

1. The Discharger shall comply with all Standard Provisions (Attachment D) related to monitoring, reporting, and recordkeeping.
2. If there is no discharge during any reporting period, the report shall so state.
3. Each monitoring report shall contain a separate section titled "Summary of Non-Compliance" which discusses the compliance record and corrective actions taken or planned that may be needed to bring the discharge into full compliance with waste discharge requirements. This section shall clearly list all non-compliance with waste discharge requirements, as well as all excursions of effluent limitations.
4. The Discharger shall inform the Regional Water Board well in advance of any proposed construction activity that could potentially affect compliance with applicable requirements

B. Self Monitoring Reports

1. At any time during the term of this General Permit, the State or Regional Water Board may notify the Discharger to electronically submit Self-Monitoring Reports (SMRs) using the State Water Board's California Integrated Water Quality System (CIWQS) Program Web site (<http://www.waterboards.ca.gov/ciwqs/index.html>). Until such notification is given, the Discharger shall email electronic copy of SMRs to losangeles@waterboards.ca.gov. The CIWQS Web site will provide additional directions for SMR submittal in the event there will be service interruption for electronic submittal.
2. Paperless Submittal of SMRs: SMRs must be submitted to the Regional Water Board, signed and certified as required by the Standard Provisions (Attachment D). The Regional Water Board is implementing a paperless office system to reduce paper use, increase efficiency and provide a more effective way for our staff, the public and interested parties to view water quality documents. Therefore, please convert all regulatory documents, submissions, data and correspondence that you would normally submit to us as hard copies to a searchable Portable Document Format (PDF). Documents that are less than 10 MB should be emailed to losangeles@waterboards.ca.gov. Documents that are 10 MB or larger should be transferred to a disk and mailed to the address listed below.

CRWQCB – Los Angeles Region
320 West 4th Street, Suite 200
Los Angeles, CA 90013
Attn: Information & Technology Unit

If you need additional information regarding electronic submittal of documents please visit and navigate the Paperless Office pages in the Regional Water Board's website at <http://www.waterboards.ca.gov/losangeles/resources/Paperless/>.

3. The Discharger shall report in the SMR the results for all monitoring specified in this MRP. The Discharger shall submit SMRs including the results of all required monitoring using USEPA-approved test methods or other test methods specified in this Order. If the Discharger monitors any pollutant more frequently than required by this Order, the results of this monitoring shall be included in the calculations and reporting of the data submitted in the SMR.
4. Monitoring periods and reporting for all required monitoring shall be completed according to the following schedule:

Table 3. Monitoring Periods and Reporting Schedule

Sampling Frequency	Monitoring Period Begins On	Monitoring Period	SMR Due Date
Continuously	March 12, 2014	Continuously	Submit with quarterly SMR
Monthly	First day of calendar month following permit effective date or on permit effective date if that date is first day of the month	1 st day of calendar month through last day of calendar month	Submit with quarterly SMR
Quarterly	Closest of January 1, April 1, July 1, or October 1 following March 12, 2014	January 1 through March 31 April 1 through June 30 July 1 through September 30 October 1 through December 31	45 days from the end of the monitoring period
Annually	January 1 following (or on) March 12, 2014	January 1 through December 31	45 days from the end of the monitoring period

5. Reporting Protocols. The Discharger shall report with each sample result the applicable Reporting Level (RL) and the current Method Detection Limit (MDL), as determined by the procedure in Part 136.

The Discharger shall report the results of analytical determinations for the presence of chemical constituents in a sample using the following reporting protocols:

- a. Sample results greater than or equal to the RL shall be reported as measured by the laboratory (i.e., the measured chemical concentration in the sample).
- b. Sample results less than the RL, but greater than or equal to the laboratory's MDL, shall be reported as "Detected, but Not Quantified," or DNQ. The estimated chemical concentration of the sample shall also be reported.

For the purposes of data collection, the laboratory shall write the estimated chemical concentration next to DNQ as well as the words "Estimated Concentration" (may be shortened to "Est. Conc."). The laboratory may, if such information is available, include numerical estimates of the data quality for the reported result. Numerical estimates of

data quality may be percent accuracy (\pm a percentage of the reported value), numerical ranges (low to high), or any other means considered appropriate by the laboratory.

- c. Sample results less than the laboratory's MDL shall be reported as "Not Detected," or ND.
 - d. Dischargers are to instruct laboratories to establish calibration standards so that the ML value (or its equivalent if there is differential treatment of samples relative to calibration standards) is the lowest calibration standard. At no time is the Discharger to use analytical data derived from *extrapolation* beyond the lowest point of the calibration curve.
6. The Discharger shall submit SMRs in accordance with the following requirements:
- a. Data Summary Tables: The Discharger shall arrange all reported data in a tabular format. The data shall be summarized to clearly illustrate whether the facility is operating in compliance with interim and/or final effluent limitations. The Discharger is not required to duplicate the submittal of data that is entered in a tabular format within CIWQS. When electronic submittal of data is required and CIWQS does not provide for entry into a tabular format within the system, the Discharger shall electronically submit the data in a tabular format as an attachment.
 - b. Cover letter and Summary of Non-Compliance: The Discharger shall attach a cover letter to the SMR. The information contained in the cover letter shall clearly identify violations of the WDRs; discuss corrective actions taken or planned; and the proposed time schedule for corrective actions. Identified violations must include a description of the requirement that was violated and a description of the violation.

C. Discharge Monitoring Reports (DMRs) (Not Applicable)

D. Other Reports (Not Applicable)

E. Notification

- A. The Discharger shall notify the Executive Officer in writing prior to discharge of any chemical which may be toxic to aquatic life. Such notification shall include:
 - 1. Name and general composition of the chemical,
 - 2. Frequency of use,
 - 3. Quantities to be used,
 - 4. Proposed discharge concentrations and,
 - 5. EPA registration number, if applicable.

No discharge of such chemical shall be made prior to obtaining the Executive Officer's approval.

- B. The Discharger shall notify the Regional Board by calling Alex Carlos at (213) 576-6726 and/or email to acarlos@waterboards.c.gov within 24 hours of noticing an exceedance above the effluent limits in Order No. R4-2013-0095. The Discharger shall provide to

the Regional Water Board within 14 days of observing the exceedance a detailed statement of the actions undertaken or proposed that will bring the discharge into full compliance with the requirements and submit a timetable for correction.

XI. MONITORING FREQUENCIES ADJUSTMENT

Monitoring frequencies may be adjusted by the Executive Officer to a less frequent basis if the Discharger makes a request and the request is backed by statistical trends of monitoring data submitted.