

**CALIFORNIA REGIONAL WATER QUALITY CONTROL BOARD
LOS ANGELES REGION**

320 West 4th Street, Suite 200, Los Angeles, California 90013
(213) 576-6600 • Fax (213) 576-6640

Los Angeles Regional Water Quality Control Board
<http://www.waterboards.ca.gov>

**ORDER R4-2021-XXXX
NPDES NO. CA0064599**

**WASTE DISCHARGE REQUIREMENTS FOR THE TFX AVIATION, INC. FACILITY,
VENTURA COUNTY, DISCHARGE TO SOUTH FORK OF ARROYO CONEJO CREEK**

The following Discharger is subject to waste discharge requirements (WDRs) set forth in this Order:

Table 1. Discharger Information

Discharger:	TFX Aviation, Inc. (TFX, Discharger, or Permittee)
Name of Facility:	TFX Aviation, Inc. Facility (Facility)
Facility Address:	3085 Old Conejo Road Newbury Park, CA 91320 Ventura County

Table 2. Discharge Location

Discharge Point	Effluent Description	Discharge Point Latitude (North-South)	Discharge Point Longitude (East-West)	Receiving Water
001	Treated Groundwater	34.1896° N	-118.9399° W	South Fork of Arroyo Conejo Creek

Table 3. Administrative Information

This Order was adopted on:	June 10, 2021
This Order shall become effective on:	August 01, 2021
This Order shall expire on:	July 31, 2026
The Discharger shall file a Report of Waste Discharge (ROWD) as an application for reissuance of WDRs in accordance with title 23, California Code of Regulations, and an application for reissuance of a NPDES permit no later than:	180 days prior to the Order expiration date
The United States Environmental Protection Agency (U.S. EPA) and the California Regional Water Quality Control Board have classified this discharge as follows:	Minor

TFX AVIATION, INC.
TFX AVIATION, INC. FACILITY

ORDER R4-2021-XXXX
NPDES NO. CA0064599

I, Renee Purdy, Executive Officer, do hereby certify that this Order with all attachments is a full, true, and correct copy of the Order adopted by the California Regional Water Quality Control Board, Los Angeles Region, on **the date indicated above**.

Renee Purdy, Executive Officer

TABLE OF CONTENTS

1. FACILITY INFORMATION	4
2. FINDINGS	4
3. DISCHARGE PROHIBITIONS	4
4. EFFLUENT LIMITATIONS AND DISCHARGE PROHIBITIONS.....	5
4.1. Effluent Limitations – Discharge Point 001	5
4.2. Land Discharge Specifications – Not Applicable	10
4.3. Recycling Specifications - Not Applicable.....	10
5. RECEIVING WATER LIMITATIONS.....	10
5.1. Surface Water Limitations.....	10
6. PROVISIONS	12
6.1. Standard Provisions	12
6.2. Monitoring and Reporting Program (MRP) Requirements	14
6.3. Special Provisions	14
7. COMPLIANCE DETERMINATION	16

TABLE OF TABLES

Table 1. Discharger Information	1
Table 2. Discharge Location	1
Table 3. Administrative Information	1
Table 4. Effluent Limitations	5
Table 5. Effluent Limitations for Copper and Nickel Based on <i>Calleguas Creek Watershed TMDL for Metals</i> (Resolution No. R4-2006-012)	10

TABLE OF ATTACHMENTS

ATTACHMENT A – DEFINITIONS	1
ATTACHMENT B1 – SITE LOCATION MAP.....	1
ATTACHMENT B2 – OUTFALL EFF- 001 LOCATION.....	1
ATTACHMENT C1 – FLOW SCHEMATIC	1
ATTACHMENT C2 – GROUNDWATER TREATMENT FACILITY DIAGRAM.....	1
ATTACHMENT D – STANDARD PROVISIONS.....	1
ATTACHMENT E – MONITORING AND REPORTING PROGRAM (MRP) (CI NO. 9544).....	1
ATTACHMENT F – FACT SHEET.....	1
ATTACHMENT G - STORMWATER POLLUTION PREVENTION PLAN REQUIREMENTS.....	1

1. FACILITY INFORMATION

Information describing the TFX Aviation, Inc. Facility (Facility) is summarized in Table 1 and in sections 1 and 2 of the Fact Sheet (Attachment F). Section 1 of the Fact Sheet also includes information regarding the Facility's permit application.

2. FINDINGS

The California Regional Water Quality Control Board, Los Angeles Region (Los Angeles Water Board), finds:

- 2.1. **Legal Authorities.** This Order serves as waste discharge requirements (WDRs) pursuant to article 4, chapter 4, division 7 of the California Water Code (commencing with section 13260). This Order is also issued pursuant to section 402 of the federal Clean Water Act (CWA) and implementing regulations adopted by the United States Environmental Protection Agency (U.S. EPA) and chapter 5.5, division 7 of the Water Code (commencing with section 13370). It shall serve as a National Pollutant Discharge Elimination System (NPDES) permit authorizing the Discharger to discharge into waters of the United States at the discharge location described in Table 2 subject to the WDRs in this Order.
- 2.2. **Background and Rationale for Requirements.** The Los Angeles Water Board developed the requirements in this Order based on information submitted as part of the application and through the Discharger's monitoring and reporting program along with other available information. The Fact Sheet (Attachment F), which contains background information and rationale for the requirements in this Order, is hereby incorporated into and constitutes Findings for this Order. Attachments A through E and G are also incorporated into this Order.
- 2.3. **Notification of Interested Parties.** The Los Angeles Water Board has notified the Discharger and interested agencies and persons of its intent to prescribe WDRs for the discharge and has provided them with an opportunity to submit their written comments and recommendations. Details of the notification are provided in the Fact Sheet.
- 2.5. **Consideration of Public Comment.** The Los Angeles Water Board, in a public meeting, heard and considered all comments pertaining to the discharge. Details of the Public Hearing are provided in the Fact Sheet.

THEREFORE, IT IS HEREBY ORDERED that Order No. R4-2015-0106 is rescinded upon the effective date of this Order except for enforcement purposes, and, in order to meet the provisions contained in division 7 of the Water Code (commencing with section 13000) and regulations adopted thereunder, and the provisions of the CWA and regulations and guidelines adopted thereunder, the Discharger shall comply with the requirements in this Order. This action in no way prevents the Los Angeles Water Board from taking enforcement action for violations of the previous Order.

3. DISCHARGE PROHIBITIONS

- 3.1. Wastes discharged shall be limited to a maximum of 0.110 million gallons per day (MGD) of treated groundwater. The discharge of wastes from accidental spills or other sources is prohibited.

- 3.2. The discharge of treated groundwater at a location different from that described in this Order is prohibited and constitutes a violation of the Order.
- 3.3. Discharges of water, materials, thermal wastes, elevated temperature wastes, toxic wastes, deleterious substances, or wastes other than those authorized by this Order, to a storm drain system, the South Fork of Arroyo Conejo Creek, or other waters of the United States, are prohibited.
- 3.4. Neither the treatment nor the discharge of pollutants shall create pollution, contamination, or create a nuisance as defined by section 13050 of the Water Code.
- 3.5. Wastes discharged shall not contain any substances in concentrations toxic to human, animal, plant, or aquatic life.
- 3.6. The discharge shall not cause or contribute to a violation of any applicable water quality standards for receiving waters established as required by the federal CWA and regulations adopted thereunder.
- 3.7. Discharge of oil or any residuary product of petroleum to waters of the United States, except in accordance with waste discharge requirements or other provisions of division 7 of the Water Code, is prohibited.
- 3.8. The discharge of any radiological, chemical, or biological warfare agent or high-level radiological waste is prohibited under Water Code 13375.
- 3.9. The discharge of any waste resulting from the combustion of toxic or hazardous wastes to any waste stream that ultimately discharges to surface waters is prohibited, unless specifically authorized elsewhere in this Order.
- 3.10. The discharge of trash to surface waters of the State or the deposition of trash where it may be discharged into surface waters of the State is prohibited.

4. EFFLUENT LIMITATIONS AND DISCHARGE PROHIBITIONS

4.1. Effluent Limitations - Discharge Point 001

4.1.1. Final Effluent Limitations – Discharge Point 001

- a. The Discharger shall maintain compliance with the following effluent limitations in Tables 4 and 5 at Discharge Point 001, with compliance measured at Monitoring Location EFF-001 as described in the Monitoring and Reporting Program (MRP), Attachment E:

Table 4. Effluent Limitations

Parameter	Units (Note a)	Average Monthly	Maximum Daily	Notes
Biochemical Oxygen Demand (BOD ₅ 20°C)	mg/L	20	30	---
(BOD ₅ 20°C)	lbs/day	18	28	---
Total Suspended Solids (TSS)	mg/L	50	75	---

Parameter	Units (Note a)	Average Monthly	Maximum Daily	Notes
TSS	lbs/day	46	69	---
Oil and Grease	mg/L	10	15	---
Oil and Grease	lbs/day	9	14	---
pH	Standard unit	---	6.5 Min 8.5 Max	Note b
Temperature	°F	---	80	Note c
Settleable Solids	mL/L	0.1	0.2	---
Turbidity	NTU	50	75	---
Sulfides	mg/L	---	1	---
Sulfides	lbs/day	---	0.92	---
Sulfate	mg/L	---	250	Note d
Sulfate	lbs/day	---	229	---
Boron	mg/L	---	1.0	Note d
Boron	lbs/day	---	0.92	---
Chloride	mg/L	---	150	Note d
Chloride	lbs/day	---	138	---
Total Dissolved Solids	mg/L	---	850	Note d
Total Dissolved Solids	lbs/day	---	780	---
Nitrate + Nitrite as N	mg/L	---	10	---
Nitrate+ Nitrite as N	lbs/day	---	9.2	---
Phenols	mg/L	---	1	Note k
Phenols	lbs/day	---	0.92	Note k
Chronic Toxicity	Pass or Fail, % Effect	Pass	Pass or % Effect <50	Note e
Chromium VI, Total Recoverable (TR)	µg/L	5.5	16.3	Note f
Chromium VI, TR	lbs/day	0.005	0.015	---
Mercury, TR	µg/L	---	0.051	Note g
Mercury, TR	lbs/day	---	0.00005	---
Selenium, TR	µg/L	4.4	7.2	Note f
Selenium, TR	lbs/day	0.004	0.007	---
Silver, TR	µg/L	22	44	---
Silver, TR	lbs/day	0.02	0.04	---

Parameter	Units (Note a)	Average Monthly	Maximum Daily	Notes
TCDD Equivalents	µg/L	1.40E-08	2.80E-08	Note h
TCDD Equivalents	lbs/day	1.30E-11	2.60E-11	---
Trichloroethylene	µg/L	---	5	---
Trichloroethylene	lbs/day	--	0.005	---
Benzene	µg/L	---	1	---
Benzene	lbs/day	---	0.0009	---
Toluene	µg/L	---	10	---
Toluene	lbs/day	---	0.009	---
Xylene	µg/L	---	10	---
Xylene	lbs/day	---	0.009	---
Ethylbenzene	µg/L	---	10	---
Ethylbenzene	lbs/day	---	0.009	---
Dichlorobromomethane	µg/L	---	100	---
Dichlorobromomethane	lbs/day	---	0.092	---
Carbon Tetrachloride	µg/L	---	0.5	---
Carbon Tetrachloride	lbs/day	---	0.0005	---
1,1-Dichloroethane	µg/L	---	5	---
1,1-Dichloroethane	lbs/day	---	0.005	---
1,2-Dichloroethane	µg/L	---	0.5	---
1,2-Dichloroethane	lbs/day	---	0.0005	---
1,1-Dichloroethylene	µg/L	---	6	---
1,1-Dichloroethylene	lbs/day	---	0.006	---
Trans1,2-Dichloroethylene	µg/L	---	10	---
Trans1,2-Dichloroethylene	lbs/day	---	0.009	---
Tetrachloroethylene	µg/L	---	5	---
Tetrachloroethylene	lbs/day	---	0.005	---
Vinyl Chloride	µg/L	---	0.5	---
Vinyl Chloride	lbs/day	---	0.0005	---
Bis(2-Ethylhexyl)Phthalate	µg/L	4	8	---

Parameter	Units (Note a)	Average Monthly	Maximum Daily	Notes
Bis(2-Ethylhexyl)Phthalate	lbs/day	0.004	0.007	---
Chlordane	µg/L	0.0006	0.001	Note i
Chlordane	lbs/day	0.0000005	0.000001	---
4,4-DDD	µg/L	0.0008	0.002	Note i
4,4-DDD	lbs/day	0.0000008	0.000002	---
4,4-DDE	µg/L	0.0006	0.001	Note i
4,4-DDE	lbs/day	0.0000005	0.000001	---
4,4-DDT	µg/L	0.0006	0.0012	Note i
4,4-DDT	lbs/day	0.0000005	0.000001	---
Dieldrin	µg/L	0.0001	0.0003	Note i
Dieldrin	lbs/day	0.0000001	0.0000003	---
Polychlorinated Biphenyls (PCBs)	µg/L	0.0002	0.0003	Note i
PCBs	lbs/day	0.0000002	0.0000003	---
Toxaphene	µg/L	0.0002	0.0003	Note i
Toxaphene	lbs/day	0.0000002	0.0000003	---
Phenolic Compounds (Chlorinated)	µg/L	---	1	Note l
Phenolic Compounds (Chlorinated)	lbs/day	---	0.00092	Note l
Chlorpyrifos	µg/L	0.014	0.025	Note j
Chlorpyrifos	lbs/day	0.00001	0.00002	---
Diazinon	µg/L	0.10	0.10	Note j
Diazinon	lbs/day	0.00009	0.00009	---

Footnotes for Table 4

- a. µg/L = micrograms per Liter
 lbs/day = pounds per day
 NTU = nephelometric turbidity units
 °F = Degrees Fahrenheit
- mg/L = milligrams per Liter
 ml/L = milliliters per Liter
 TST = Test of Significant Toxicity

The mass-based effluent limitations are based on the plant design flow rate of 0.110 mgd and are calculated as follows: Flow (mgd) x Concentration (mg/L) x 8.34 (conversion factor) = lbs/day.

- b. The effluent limitations for pH are 6.5 as an Instantaneous Minimum and 8.5 as an Instantaneous Maximum.
- c. The effluent limitation for temperature is 80°F based on the water quality objective in the Basin Plan for temperature that is applicable to inland surface waters with WARM beneficial use designation such as the South Fork of Arroyo Conejo Creek. The applicable water quality objective (WQO)

states: "For waters designated WARM, water temperature shall not be altered by more than 5 °F above the natural temperature. At no time shall these WARM-designated waters be raised above 80 °F as a result of waste discharges."

- d. The concentration-based effluent limitations are based on the *Calleguas Creek Watershed TMDL for Boron, Chloride, Sulfate, and Total Dissolved Solids (Salts)*.
- e. The average monthly is a Median Monthly Effluent Limitation (MMEL), and the MMEL shall be reported as "Pass" or "Fail." The Maximum Daily Effluent Limitation (MDEL) shall be reported as "Pass" or "Fail" and "% Effect." During a calendar month, up to three independent toxicity tests are required for routine monitoring when one toxicity test results in "Fail".
- f. The effluent limitations were calculated based on the SIP procedures.
- g. The concentration-based effluent limitations are based on the *Calleguas Creek Watershed Metals and Selenium TMDL*.
- h. TCDD equivalents shall be calculated using the following formula, where the toxicity equivalency factors (TEFs) are as provided in the table below. The Discharger shall report all measured values of individual congeners, including data qualifiers. When calculating TCDD equivalents, the Discharger shall set congener concentrations below the minimum levels to zero. The TCDD equivalents are calculated as follows: $\text{Dioxin-TEQ (TCDD equivalents)} = \text{Sum of Concentration of dioxin or furan congener}_x \times \text{Toxicity Equivalency Factors (TEFs) for congener}_x$. The TEFs are listed in the Table Below.

Toxicity Equivalency Factors

Congeners	Minimum Level (pg/L)	Toxicity Equivalence Factor (TEF)
2,3,7,8 - tetra CDD	10	1.0
1,2,3,7,8 - penta CDD	50	1.0
1,2,3,4,7,8 - hexa CDD	50	0.1
1,2,3,6,7,8 - hexa CDD	50	0.1
1,2,3,7,8,9 - hexa CDD	50	0.1
1,2,3,4,6,7,8 - hepta CDD	50	0.01
Octa CDD	100	0.0001
2,3,7,8 - tetra CDF	10	0.1
1,2,3,7,8 - penta CDF	50	0.05
2,3,4,7,8 - penta CDF	50	0.5
1,2,3,4,7,8 - hexa CDF	50	0.1
1,2,3,6,7,8 - hexa CDF	50	0.1
1,2,3,7,8,9 - hexa CDF	50	0.1
2,3,4,6,7,8 - hexa CDF	50	0.1
1,2,3,4,6,7,8 - hepta CDFs	50	0.01
1,2,3,4,7,8,9 - hepta CDFs	50	0.01
Octa CDF	100	0.0001

- i. The concentration-based effluent limitations are based on the *Calleguas Creek Watershed TMDL for Organochlorine (OC) Pesticides, Polychlorinated Biphenyls (PCBs), and Siltation*.

- j. The effluent limitations are derived from the final waste load allocation (WLA) as set forth in the *Calleguas Creek Watershed Toxicity, Chlorpyrifos, and Diazinon TMDL*.
- k. Phenols are comprised of the following constituents from the CTR list of priority pollutants: phenol, 2,4-dimethylphenol, 2-methyl-4,6-dinitrophenol, 2,4-dinitrophenol, 2-nitrophenol, and 4-nitrophenol.
- l. Chlorinated phenolic compounds are comprised of the following constituents from the CTR list of priority pollutants: 2-chlorophenol, 2,4-dichlorophenol, 3-methyl-4-chlorophenol, pentachlorophenol, and 2,4,6-trichlorophenol.

End of Footnotes for Table 4

Table 5. Effluent Limitations for Copper and Nickel Based on the *Calleguas Creek Watershed Metals and Selenium TMDL*

Parameter	Units	Dry-Weather Monthly Average (Note a)	Wet-Weather Daily Maximum (Note b)	Notes
Copper, Total Recoverable (TR)	µg/L	29.1	43.3	
Copper, TR	lbs/day	0.03	0.04	Note c
Nickel, TR	µg/L	160	1296	
Nickel, TR	lbs/day	0.2	1.2	Note c

Footnotes for Table 5

- a. The Dry-Weather Monthly Average effluent limits apply when flow in the receiving water is less than the 86th percentile flow rate for the South Fork of Arroyo Conejo. If flow data are unavailable for the South Fork of Arroyo Conejo, the 86th percentile flow rate (29.7 cubic feet per second (cfs)) for Calleguas Creek at PCH shall be used (see Section 9.3, Final Technical Report - Calleguas Creek Watershed Metals and Selenium TMDL, Revised May 2006, p. 142).
- b. The Wet-Weather Daily Maximum effluent limits apply when flow in the receiving water exceeds the 86th percentile flow rate.
- c. The mass-based effluent limitations for pollutants are based on a maximum discharge flow rate of 0.110 mgd and are calculated as follows: Flow (mgd) x Concentration (mg/L) x 8.34 (conversion factor) = lbs/day.

End of Footnotes for Table 5

4.2. Land Discharge Specifications – Not Applicable

4.3. Recycling Specifications - Not Applicable

5. RECEIVING WATER LIMITATIONS

5.1. Surface Water Limitations

Receiving water limitations are based on the water quality objectives in the Basin Plan. The discharge shall not cause the following in the receiving water:

- 5.1.1. The pH of the receiving water to be depressed below 6.5 or raised above 8.5 as a result of the discharge. Ambient pH levels shall not be changed more than 0.5 units from natural conditions as a result of waste discharge. Natural conditions shall be determined on a case-by-case basis.

- 5.1.2. Water temperature to be altered by more than 5 °F above the natural temperature. At no time shall the temperature be raised above 80 °F as a result of waste discharges.
- 5.1.3. The six-week rolling geometric mean for *Escherichia coli* (*E. coli*) to exceed 100 colony forming units (cfu) per 100 milliliters (mL) or 100 most probable number (mpn) per 100 mL, calculated weekly; and the statistical threshold value (STV) of 320 cfu/100 mL or 320 mpn/100 mL for *E. coli* shall not be exceeded by more than 10 percent of the samples collected in a calendar month, calculated in a static manner.
- 5.1.4. The dissolved oxygen content of all surface waters designated as WARM to be depressed below 5.0 mg/L as a result of waste discharges.
- 5.1.5. The presence of visible, floating, suspended or deposited macroscopic particulate matter or foam
- 5.1.6. Where natural turbidity is between 0 to 50 NTU, increases in turbidity to exceed 20%. Where natural turbidity is greater than 50 NTU, increases in turbidity to exceed 10%.
- 5.1.7. Oils, greases, waxes, or other materials in concentrations that result in a visible film or coating on the surface of the receiving water or on objects in the water.
- 5.1.8. Suspended or settleable materials, chemical substances, or pesticides in amounts that cause nuisance or adversely affect any designated beneficial use.
- 5.1.9. Toxic or other deleterious substances in concentrations or quantities which cause deleterious effects on aquatic biota, wildlife, or waterfowl or render any of these unfit for human consumption either at levels created in the receiving waters or as a result of biological concentration.
- 5.1.10. Accumulation of bottom deposits or aquatic growths.
- 5.1.11. Biostimulatory substances at concentrations that promote aquatic growth to the extent that such growth causes nuisance or adversely affects beneficial uses.
- 5.1.12. The presence of substances that result in increases of BOD that adversely affect beneficial uses.
- 5.1.13. Taste or odor-producing substances in concentrations that alter the natural taste, odor, and/or color of fish, shellfish, or other edible aquatic resources; cause nuisance; or adversely affect beneficial uses.
- 5.1.14. Alteration of turbidity, or apparent color beyond present natural background levels.
- 5.1.15. Damage, discoloration, or the formation of sludge deposits on flood control structures or facilities or overloading of the design capacity.
- 5.1.16. Degradation of surface water communities and populations including vertebrate, invertebrate, and plant species.
- 5.1.17. Problems associated with breeding of mosquitoes, gnats, black flies, midges, or other pests.
- 5.1.18. The creation of nuisance, or adversely affect beneficial uses of the receiving water.

5.1.19. Total ammonia (as N) concentrations to exceed the four-day average concentration of unionized ammonia of 0.035 mg/L and the one-hour average concentration of 0.233 mg/L.

5.2. Groundwater Limitations

The discharge shall not cause the underlying groundwater to be degraded except as consistent with State Water Board Resolution No. 68-16. The discharge to groundwater shall not exceed WQOs, unreasonably affect beneficial uses, or cause a condition of pollution or nuisance.

6. PROVISIONS

6.1. Standard Provisions

6.1.1. The Discharger shall comply with all Standard Provisions included in Attachment D.

6.1.2. The Discharger shall comply with the following provisions. If there is any conflict, duplication, or overlap between provisions specified by this Order, the more stringent provision shall apply:

- a. The Discharger must comply with the lawful requirements of municipalities, counties, drainage districts, and other local agencies regarding discharges of wastewater and stormwater to storm drain systems or other water courses under their jurisdiction, including applicable requirements in municipal stormwater management programs developed to comply with NPDES permits issued by the Los Angeles Water Board to local agencies.
- b. The Discharger shall comply with all applicable effluent limitations, national standards of performance, toxic effluent standards, and all federal regulations established pursuant to sections 301, 302, 303(d), 304, 306, 307, 316, 318, 405, and 423 of the federal CWA and amendments thereto.
- c. These requirements do not exempt the operator of the waste disposal facility from compliance with any other laws, regulations, or ordinances which may be applicable, they do not legalize this waste disposal facility, and they leave unaffected any further restraints on the disposal of wastes at this site which may be contained in other statutes or required by other agencies.
- d. Oil or oily material, chemicals, refuse, or other wastes that constitute a condition of pollution or nuisance shall not be stored or deposited in areas where they may be picked up by rainfall and carried off of the property and/or discharged to surface waters. Any such spill of such materials shall be contained and removed immediately.
- e. A copy of these waste discharge requirements shall be maintained at the discharge facility so as to be available at all times to operating personnel.
- f. After notice and opportunity for a hearing, this Order may be terminated or modified for cause, including, but not limited to:
 - i. Violation of any term or condition contained in this Order;
 - ii. Obtaining this Order by misrepresentation, or failure to disclose all relevant facts;

- iii. A change in any condition that requires either a temporary or permanent reduction or elimination of the authorized discharge.
- g. In the event of any change in name, ownership, or control of these waste disposal facilities, the Discharger shall notify the Los Angeles Water Board of such change 30 days prior to taking effect and shall notify the succeeding owner or operator of the existence of this Order by letter, copy of which shall be forwarded to the Los Angeles Water Board.
- h. If there is any storage of hazardous or toxic materials or hydrocarbons at this Facility and if the Facility is not staffed at all times, a 24-hour emergency response telephone number shall be prominently posted where it can easily be read from the outside.
- i. Violation of any of the provisions of this Order may subject the violator to any of the civil liability or penalties described herein, or any combination thereof, at the discretion of the prosecuting authority, except that only one kind of liability or penalty may be applied for each kind of violation.
- j. The Discharger shall notify the Executive Officer in writing no later than 6 months prior to the planned discharge of any chemical, other than the products previously reported to the Executive Officer, which may be toxic to aquatic life. Such notification shall include.
 - i. Name and general composition of the chemical,
 - ii. Frequency of use,
 - iii. Quantities to be used,
 - iv. Proposed discharge concentrations, and
 - v. U.S. EPA registration number, if applicable
- k. Failure to comply with provisions or requirements of this Order, or violation of other applicable laws or regulations governing discharges from this Facility, may subject the Discharger to administrative or civil liabilities, civil or criminal penalties, and/or other enforcement remedies to ensure compliance. Additionally, certain violations may subject the Discharger to civil or criminal enforcement from appropriate local, state, or federal law enforcement entities.
- l. In the event the Discharger does not comply or will be unable to comply for any reason, with any prohibition, effluent limitation, or receiving water limitation of this Order, the Discharger shall notify the Los Angeles Water Board by telephone (213) 576-6600 within 24 hours of having knowledge of such noncompliance, and shall confirm this notification in writing within five days, unless the Los Angeles Water Board waives confirmation. The written notification shall state the nature, time, duration, and cause of noncompliance, and shall describe the measures being taken to remedy the current noncompliance and prevent recurrence including, where applicable, a schedule of implementation. The written notification shall also be submitted via email with reference to NPDES No. CA0064599, CI-9544 to losangeles@waterboards.ca.gov. Other noncompliance requires written notification as above at the time of the normal monitoring report

- m. The provisions of this Order are severable. If any provision of this Order is found invalid, the remainder of this Order shall not be affected.
- n. Nothing in this Order shall be construed to preclude the institution of any legal action or relieve the Discharger from any responsibilities, liabilities or penalties to which the Discharger is or may be subject to under section 311 of the CWA.
- o. The Discharger shall make diligent, proactive efforts to reduce Facility infrastructure vulnerability to current and future impacts resulting from climate change, including but not limited to extreme wet weather events, flooding, storm surges, wildfires and projected sea level rise when the facility is located near the ocean or discharges to the ocean.
- p. The discharge of any product registered under the Federal Insecticide, Fungicide, and Rodenticide Act to any waste stream that may ultimately be released to waters of the United States, is prohibited unless specifically authorized elsewhere in this Order or another NPDES permit. This requirement is not applicable to products used for lawn and agricultural purposes.

6.2. Monitoring and Reporting Program (MRP) Requirements

The Discharger shall comply with the MRP, and future revisions thereto, in Attachment E.

6.3. Special Provisions

6.3.1. Reopener Provisions

- a. If more stringent applicable water quality standards are promulgated or approved pursuant to section 303 of the federal CWA, and amendments thereto, the Los Angeles Water Board may revise and modify this Order in accordance with such more stringent standards.
- b. This Order may be reopened to include effluent limitations for toxic constituents determined to be present in significant amounts in the discharge through a more comprehensive monitoring program included as part of this Order and based on the results of the reasonable potential analysis (RPA).
- c. This Order may be reopened and modified, in accordance with the provisions set forth in 40 CFR parts 122 and 124, to include requirements for the implementation of the watershed management approach or to include new minimum levels (MLs).
- d. This Order may be reopened and modified to revise effluent limitations as a result of future Basin Plan Amendments, such as an update of an objective or the adoption or revision of a TMDL for the Calleguas Creek Watershed.
- e. This Order may be reopened upon submission by the Discharger of adequate information, as determined by the Los Angeles Water Board, to provide for dilution credits or a mixing zone, as may be appropriate.
- f. This Order may also be modified, revoked, and reissued or terminated in accordance with the provisions of 40 CFR sections 122.44, 122.62 to 122.64, 125.62, and 125.64. Causes for taking such actions include, but are not limited to, failure to comply with any condition of this Order, endangerment to human

health or the environment resulting from the permitted activity, or acquisition of newly obtained information which would have justified the application of different conditions if known at the time of Order adoption. The filing of a request by the Discharger for an Order modification, revocation and issuance, or termination, or a notification of planned changes or anticipated noncompliance does not stay any condition of this Order.

- g. This Order may be reopened for modification, or revocation and reissuance, as a result of the detection of a reportable priority pollutant generated by special conditions included in this Order. These special conditions may include, but are not limited to, fish tissue sampling, whole effluent toxicity, monitoring requirements on internal waste stream(s), and monitoring for surrogate parameters. Additional requirements may be included in this Order as a result of the special condition monitoring data.

6.3.2. **Special Studies, Technical Papers and Additional Monitoring Requirements**

a. **Initial Investigation Toxicity Reduction Evaluation (TRE) Workplan**

The Discharger shall submit to the Los Angeles Water Board an Initial Investigation TRE workplan (1-2 pages) within **90 days** of the effective date of this Order. This plan shall describe the steps the permittee intends to follow in the event that toxicity is detected. See section 5.8 of the Monitoring and Reporting Program (Attachment E) for an overview of TRE requirements

6.3.3. **Best Management Practices and Pollution Prevention**

The Discharger shall submit to the Los Angeles Water Board, within 90 days of the effective date of this Order:

- a. **Storm Water Pollution Prevention Plan (SWPPP)** that describes site specific management practices for minimizing contamination of stormwater runoff and for preventing contaminated stormwater runoff from being discharged directly to the waters of the state. The SWPPP shall be developed in accordance with the requirements in Attachment G.
- b. **Best Management Practices Plan (BMPP)** that will be implemented to reduce the discharge of pollutants to the receiving water. The BMPP shall include site-specific plans and procedures implemented and/or to be implemented to prevent hazardous waste/material and trash from being discharged to waters of the State. Further, the Discharger shall ensure that the stormwater discharges from the Facility would neither cause nor contribute to a nuisance in the receiving water, and that unauthorized discharges (i.e. spills) to the receiving water have been effectively prohibited. In particular, a risk assessment of each area identified by the Discharger shall be performed to determine the potential for hazardous or toxic waste/material and trash discharge to surface waters. The BMPP can be included and submitted with the SWPPP.
- c. **Spill Contingency Plan (SCP)** that shall include a technical report on the preventive (failsafe) and contingency (cleanup) plans for controlling accidental discharges, and for minimizing the effect of such events at the site. The SCP

requirement may be satisfied with an updated version of the Discharger's existing Spill Prevention Control and Countermeasure Plan.

Each plan shall cover all areas of the Facility and shall include an updated drainage map for the Facility. The Discharger shall identify on a map of appropriate scale the areas that contribute runoff to the permitted discharge point; describe the activities in each area and the potential for contamination of stormwater runoff and the discharge of hazardous waste/material; and address the feasibility of containment and/or treatment of stormwater. The plans shall be reviewed annually and at the same time. Updated information shall be submitted **within 30 days** of revision.

The Discharger shall implement the SWPPP, BMPP, and SCP (or SPCC) within **10 days** of the approval by the Executive Officer or **no later than 90 days** after submission to the Los Angeles Water Board, whichever comes first.

6.3.4. Construction, Operation and Maintenance Specifications

The Discharger shall at all times properly operate and maintain all facilities and systems installed or used to achieve compliance with this Order.

Climate Change Effects Vulnerability Assessment and Mitigation Plan. The Discharger shall consider the impacts of climate change as they affect the operation of the treatment facility due to flooding, wildfire, or other climate-related changes. The Discharger shall develop a Climate Change Effects Vulnerability Assessment and Mitigation Plan (Climate Change Plan) to assess and manage climate change-related effects associated with the wastewater treatment facility's operation, water quality, and beneficial uses. The Climate Change Plan is due **12 months** after the effective date of this Order

6.3.5. Compliance Schedules – Not Applicable

7. COMPLIANCE DETERMINATION

Compliance with the effluent limitations contained in section 4 of this Order will be determined as specified below:

7.1. Single Constituent Effluent Limitation

If the concentration of the pollutant in the monitoring sample is greater than the effluent limitation and greater than or equal to the reported Minimum Level (ML) (see Reporting Requirement 1.9 of the MRP), then the Discharger is out of compliance.

7.2. Effluent Limitations Expressed as a Sum of Several Constituents

If the sum of the individual pollutant concentrations is greater than the effluent limitation, then the Discharger is out of compliance. In calculating the sum of the concentrations of a group of pollutants, constituents reported as ND or DNQ are treated as having concentrations equal to zero, provided that the applicable ML is used.

7.3. Effluent Limitations Expressed as a Median

In determining compliance with a median limitation, the analytical results in a set of data will be arranged in order of magnitude (either increasing or decreasing order); and

7.3.1. If the number of measurements (n) is odd, then the median will be calculated as

$$= X_{(n+1)/2}$$

7.3.2. If the number of measurements (n) is even, then the median will be calculated as $= [X_{n/2} + X_{(n/2)+1}]/2$, i.e. the midpoint between the n/2 and n/2+1 data points.

7.4. Multiple Sample Data

When determining compliance with an AMEL or MDEL for priority pollutants and more than one sample result is available, the Discharger shall compute the arithmetic mean unless the data set contains one or more reported determinations of "Detected, but Not Quantified" (DNQ) or "Not Detected" (ND). In those cases, the Discharger shall compute the median in place of the arithmetic mean in accordance with the following procedure:

7.4.1. The data set shall be ranked from low to high, ranking the reported ND determinations lowest, DNQ determinations next, followed by quantified values (if any). The order of the individual ND or DNQ determinations is unimportant.

7.4.2. The median value of the data set shall be determined. If the data set has an odd number of data points, then the median is the middle value. If the data set has an even number of data points, then the median is the average of the two values around the middle unless one or both of the points are ND or DNQ, in which case the median value shall be the lower of the two data points where DNQ is lower than a value and ND is lower than DNQ.

7.5. Average Monthly Effluent Limitation (AMEL)

If the average (or when applicable, the median determined by subsection 7.3 and 7.4 above for multiple sample data) of daily discharges over a calendar month exceeds the AMEL for a given parameter, this will represent a single violation for the purpose of calculating mandatory minimum penalties, though the Discharger may be considered out of compliance for each day of that month for that parameter (e.g., resulting in 31 days of non-compliance in a 31-day month)) for the purpose of calculating discretionary administrative civil liabilities. However, an alleged violation of the AMEL will be considered one violation for the purpose of assessing mandatory minimum penalties. If only a single sample is taken during the calendar month and the analytical result for that sample exceeds the AMEL, the Discharger will be considered out of compliance for that calendar month. If multiple samples are taken the Discharger will only be considered out of compliance for days when the discharge occurs. For anyone calendar month during which no sample (daily discharge) is taken, no compliance determination can be made for that calendar month.

In determining compliance with the AMEL, the following provisions shall also apply to all constituents:

7.5.1. If the analytical result of a single sample, monitored monthly, quarterly, semiannually, or annually, does not exceed the AMEL for that constituent, the Discharger has demonstrated compliance with the AMEL for each day of the month for that parameter.

7.5.2. If the analytical result of a single sample monitored monthly, quarterly, semiannually, or annually, exceeds the AMEL for any constituent, the Discharger

shall collect four additional samples at approximately equal intervals during the same calendar month. All five analytical results shall be reported in the monitoring report for that month, or 45 days after results for the additional samples were received, whichever is later.

When all sample results are greater than or equal to the reported ML (see Reporting Requirement 1.10 of the MRP), the numerical average of the analytical results of these five samples will be used for compliance determination.

When one or more sample results are reported as "Not-Detected (ND)" or "Detected, but Not Quantified (DNQ)" (see Reporting Requirement I.I of the MRP), the median value of these four samples shall be used for compliance determination. If one or both of the middle values is ND or DNQ, the median shall be the lower of the two middle values.

7.5.3. In the event of noncompliance with an AMEL, the sampling frequency for that constituent shall be increased to weekly and shall continue at this level until compliance with the AMEL has been demonstrated.

7.5.4. If only one sample was obtained for the month or more than a monthly period and the result exceeds the AMEL; then the Discharger is in violation of the AMEL.

7.6. Maximum Daily Effluent Limitation (MDEL)

If a daily discharge exceeds the MDEL for a given parameter, an alleged violation will be flagged and the Discharger will be considered out of compliance for that parameter for that one day only within the reporting period. For any one day during which no sample is taken, no compliance determination will be made for that day.

7.7. Instantaneous Minimum Effluent Limitation

If the analytical result of a single grab sample is lower than the instantaneous minimum effluent limitation for a parameter, an alleged violation will be flagged and the Discharger will be considered out of compliance for that parameter for that single sample. Non-compliance for each sample will be considered separately (e.g., the results of two grab samples taken within a calendar day that both are lower than the instantaneous minimum effluent limitation would result in two instances of non-compliance with the instantaneous minimum effluent limitation).

7.8. Instantaneous Maximum Effluent Limitation

If the analytical result of a single grab sample is higher than the instantaneous maximum effluent limitation for a parameter, an alleged violation will be flagged, and the Discharger will be considered out of compliance for that parameter for that single sample. Non-compliance for each sample will be considered separately (e.g., the results of two grab samples taken within a calendar day that both exceed the instantaneous maximum effluent limitation would result in two instances of non-compliance with the instantaneous maximum effluent limitation).

7.9. Median Monthly Effluent Limitation (MMEL)

If the median of daily discharges over a calendar month exceeds the MMEL for a given parameter, an alleged violation will be flagged and the Discharger will be considered out of compliance for each day of that month for that parameter (e.g., resulting in 31

days of non-compliance in a 31-day month). However, an alleged violation of the MMEL will be considered one violation for the purpose of assessing State mandatory minimum penalties. If no sample (daily discharge) is taken over a calendar month, no compliance determination can be made for that month with respect to effluent violation determination, but compliance determination can be made for that month with respect to reporting violation determination.

7.10. Chronic Toxicity

The discharge is subject to determination of “Pass” or “Fail” and “Percent Effect” from a chronic toxicity test using the Test of Significant Toxicity (TST) statistical t-test approach described in National Pollutant Discharge Elimination System Test of Significant Toxicity Implementation Document (EPA 833-R-10-003, 2010), Appendix A, Figure A-1, Table A-1, and Appendix B, Table B-1. The null hypothesis (H_0) for the TST statistical approach is: Mean discharge In-stream Waste Concentration (IWC) response $\leq 0.75 \times$ Mean control response. A test result that rejects this null hypothesis is reported as “Pass.” A test result that does not reject this null hypothesis is reported as “Fail.” The relative “Percent Effect” at the discharge IWC is defined and reported as: $((\text{Mean control response} - \text{Mean discharge IWC response}) \div \text{Mean control response}) \times 100$. This is a t-test (formally Student’s t-Test), a statistical analysis comparing two sets of replicate observations - in the case of Whole Effluent Toxicity (WET), only two test concentrations (i.e., a control and IWC). The purpose of this statistical test is to determine if the means of the two sets of observations are different (i.e., if the IWC or receiving water concentration differs from the control (the test result is “Pass” or “Fail”). The Welch’s t-test employed by the TST statistical approach is an adaptation of Student’s t-test and is used with two samples having unequal variances.

The Maximum Daily Effluent Limitation (MDEL) for chronic toxicity is exceeded and a violation will be flagged when a chronic toxicity test, analyzed using the TST statistical approach, results in “Fail” and the “Percent Effect” is ≥ 50 .

The Median Monthly Effluent Limitation (MMEL) for chronic toxicity is exceeded and a violation will be flagged when the median of no more than three independent chronic toxicity tests conducted within the same calendar month—analyzed using the TST statistical approach—results in “Fail”. The MMEL for chronic toxicity shall only apply when there is a discharge on more than one day in a calendar month period. During such calendar months, up to three independent toxicity tests may be conducted when one toxicity test results in “Fail.”

The chronic toxicity MDEL and MMEL are set at the IWC for the discharge (100% effluent) and expressed in units of the TST statistical approach (“Pass” or “Fail”, “Percent Effect”). All NPDES effluent compliance monitoring for the chronic toxicity MDEL and MMEL shall be reported using only the 100% effluent concentration and negative control, expressed in units of the TST. The TST hypothesis (H_0) (see above) is statistically analyzed using the IWC and a negative control. Effluent toxicity tests shall be run using a multi-concentration test design when required by Short-term Methods for Estimating the Chronic Toxicity of Effluents and Receiving Waters to Freshwater Organisms (U.S. EPA 2002, EPA-821-R-02-013). The Los Angeles Water Board’s review of reported toxicity test results will include review of concentration-response patterns as appropriate (see Fact Sheet discussion at 4.3.6.f). As described

in the bioassay laboratory audit correspondence from the State Water Resources Control Board dated August 7, 2014, and from the U.S. EPA dated December 24, 2013, the Percent Minimum Significant Difference (PMSD) criteria only apply to compliance reporting for the No Observable Effect Concentration (NOEC) and the sublethal statistical endpoints of the NOEC, and therefore are not used to interpret TST results. Standard Operating Procedures used by the toxicity testing laboratory to identify and report valid, invalid, anomalous, or inconclusive effluent (and receiving water) toxicity test measurement results from the TST statistical approach, including those that incorporate a consideration of concentration-response patterns, must be submitted to the Regional Water Board (40 CFR section 122.41(h)). The Regional Water Board will make a final determination as to whether a toxicity test result is valid, and may consult with the Permittee, the U.S. EPA, the State Water Board's Quality Assurance Officer, or the State Water Board's Environmental Laboratory Accreditation Program (ELAP) as needed. The Board may consider the results of any TIE/TRE studies in an enforcement action.

7.11. Mass and Concentration Limitations

Compliance with mass and concentration effluent limitations for the same parameter shall be determined separately with their respective limitations. When the concentration of a constituent in an effluent sample is determined to be ND or DNQ, the corresponding mass emission rate determined from that sample concentration shall also be reported as ND or DNQ.

7.12. Bacterial Standards and Analysis

The geometric mean used for determining compliance with bacterial standards is calculated with the following equation:

$$\text{Geometric Mean} = (C_1 \times C_2 \times \dots \times C_n)^{1/n}$$

where n is the number of days samples were collected during the period and C is the concentration of bacteria (MPN/100 mL or CFU/100 mL) found on each day of sampling.

For bacterial analyses, sample dilutions should be performed so the expected range of values is bracketed (for example, with multiple tube fermentation method or membrane filtration method, 2 to 16,000 per 100 ml for total and fecal coliform, at a minimum, and 1 to 1000 per 100 ml for enterococcus). The detection methods used for each analysis shall be reported with the results of the analyses.

Detection methods used for coliforms (total and fecal) shall be those presented in Table 1A of 40 CFR part 136, unless alternate methods have been approved by U.S. EPA pursuant to 40 CFR part 136, or improved methods have been determined by the Executive Officer and/or U.S. EPA.

ATTACHMENT A – DEFINITIONS

Arithmetic Mean (μ)

Also called the average, is the sum of measured values divided by the number of samples. For ambient water concentrations, the arithmetic mean is calculated as follows:

$$\text{Arithmetic mean } (\mu) = \frac{\sum x}{n}$$

where: $\sum x$ is the sum of the measured ambient water concentrations, and n is the number of samples.

Average Monthly Effluent Limitation (AMEL)

The highest allowable average of daily discharges over a calendar month, calculated as the sum of all daily discharges measured during a calendar month divided by the number of daily discharges measured during that month.

Best Management Practices (BMPs)

BMPs are methods, measures, or practices designed and selected to reduce or eliminate the discharge of pollutants to surface waters from point and nonpoint source discharges including stormwater. BMPs include structural and non-structural controls, and operation maintenance procedures, which can be applied before, during, and/or after pollution-producing activities.

Bioaccumulative

Those substances taken up by an organism from its surrounding medium through gill membranes, epithelial tissue, or from food and subsequently concentrated and retained in the body of the organism.

Carcinogenic

Pollutants are substances that are known to cause cancer in living organisms.

Coefficient of Variation (CV)

CV is a measure of the data variability and is calculated as the estimated standard deviation divided by the arithmetic mean of the observed values.

Daily Discharge

Daily Discharge is defined as either: (1) the total mass of the constituent discharged over the calendar day (12:00 am through 11:59 pm) or any 24-hour period that reasonably represents a calendar day for purposes of sampling (as specified in the permit), for a constituent with limitations expressed in units of mass or; (2) the unweighted arithmetic mean measurement of the constituent over the day for a constituent with limitations expressed in other units of measurement (e.g., concentration).

The daily discharge may be determined by the analytical results of a composite sample taken over the course of one day (a calendar day or other 24-hour period defined as a day) or by the arithmetic mean of analytical results from one or more grab samples taken over the course of the day.

For composite sampling, if 1 day is defined as a 24-hour period other than a calendar day, the analytical result for the 24-hour period will be considered as the result for the calendar day in which the 24-hour period ends.

Detected, but Not Quantified (DNQ)

DNQ are those sample results less than the RL, but greater than or equal to the laboratory's MDL. Sample results reported as DNQ are estimated concentrations.

Dilution Credit

Dilution Credit is the amount of dilution granted to a discharge in the calculation of a water quality-based effluent limitation, based on the allowance of a specified mixing zone. It is calculated from the dilution ratio or determined through conducting a mixing zone study or modeling of the discharge and receiving water.

EC25

EC25 is a point estimate of the toxicant concentration that would cause an observable adverse effect (e.g., death, immobilization, or serious incapacitation) in 25 percent of the test organisms.

Effluent Concentration Allowance (ECA)

ECA is a value derived from the water quality criterion/objective, dilution credit, and ambient background concentration that is used, in conjunction with the coefficient of variation for the effluent monitoring data, to calculate a long-term average (LTA) discharge concentration. The ECA has the same meaning as wasteload allocation (WLA) as used in U.S. EPA guidance (Technical Support Document For Water Quality-based Toxics Control, March 1991, second printing, EPA/505/2-90-001).

Enclosed Bays

Enclosed Bays means indentations along the coast that enclose an area of oceanic water within distinct headlands or harbor works. Enclosed bays include all bays where the narrowest distance between the headlands or outermost harbor works is less than 75 percent of the greatest dimension of the enclosed portion of the bay. Enclosed bays include, but are not limited to, Humboldt Bay, Bodega Harbor, Tomales Bay, Drake's Estero, San Francisco Bay, Morro Bay, Los Angeles-Long Beach Harbor, Upper and Lower Newport Bay, Mission Bay, and San Diego Bay. Enclosed bays do not include inland surface waters or ocean waters.

Estimated Chemical Concentration

The estimated chemical concentration that results from the confirmed detection of the substance by the analytical method below the ML value.

Estuaries

Estuaries means waters, including coastal lagoons, located at the mouths of streams that serve as areas of mixing for fresh and ocean waters. Coastal lagoons and mouths of streams that are temporarily separated from the ocean by sandbars shall be considered estuaries. Estuarine waters shall be considered to extend from a bay or the open ocean to a point upstream where there is no significant mixing of fresh water and seawater. Estuarine waters included, but are not limited to, the Sacramento-San Joaquin Delta, as defined in Water Code section 12220, Suisun Bay, Carquinez Strait downstream to the Carquinez Bridge, and appropriate areas of the Smith, Mad, Eel, Noyo, Russian, Klamath, San Diego, and Otay rivers. Estuaries do not include inland surface waters or ocean waters.

Inland Surface Waters

All surface waters of the state that do not include the ocean, enclosed bays, or estuaries.

Instantaneous Maximum Effluent Limitation

The highest allowable value for any single grab sample or aliquot (i.e., each grab sample or aliquot is independently compared to the instantaneous maximum limitation).

Instantaneous Minimum Effluent Limitation

The lowest allowable value for any single grab sample or aliquot (i.e., each grab sample or aliquot is independently compared to the instantaneous minimum limitation).

Maximum Daily Effluent Limitation (MDEL)

The highest allowable daily discharge of a pollutant, over a calendar day (or 24-hour period). For pollutants with limitations expressed in units of mass, the daily discharge is calculated as the total mass of the pollutant discharged over the day. For pollutants with limitations expressed in other units of measurement, the daily discharge is calculated as the arithmetic mean measurement of the pollutant over the day.

Median

The middle measurement in a set of data. The median of a set of data is found by first arranging the measurements in order of magnitude (either increasing or decreasing order). If the number of measurements (n) is odd, then the median = $X_{(n+1)/2}$. If n is even, then the median = $(X_{n/2} + X_{(n/2)+1})/2$ (i.e., the midpoint between the $n/2$ and $n/2+1$).

Method Detection Limit (MDL)

MDL is the minimum concentration of a substance that can be reported with 99 percent confidence that the measured concentration is distinguishable from method blank results, as defined in 40 CFR part 136, Attachment B.

Minimum Level (ML)

ML is the concentration at which the entire analytical system must give a recognizable signal and acceptable calibration point. The ML is the concentration in a sample that is equivalent to the concentration of the lowest calibration standard analyzed by a specific analytical procedure, assuming that all the method specified sample weights, volumes, and processing steps have been followed.

Mixing Zone

Mixing Zone is a limited volume of receiving water that is allocated for mixing with a wastewater discharge where water quality criteria can be exceeded without causing adverse effects to the overall water body.

Not Detected (ND)

Sample results which are less than the laboratory's MDL.

PCBs (polychlorinated biphenyls) as Aroclors

The sum of chlorinated biphenyls whose analytical characteristics resemble those of Aroclor-1016, Aroclor-1221, Aroclor-1232, Aroclor-1242, Aroclor-1248, Aroclor-1254, and Aroclor-1260.

PCBs as Congeners

The sum of the following 41 individually quantified PCB congeners or mixtures of isomers of a single congeners in a co-elution: PCB-18, 28, 37, 44, 49, 52, 66, 70, 74, 77, 81, 87, 99, 101, 105, 110, 114, 118, 119, 123, 126, 128, 138, 149, 151, 153, 156, 157, 158, 167, 168, 169, 170, 177, 180, 183, 187, 189, 194, 201, and 206.

Persistent Pollutants

Persistent pollutants are substances for which degradation or decomposition in the environment is nonexistent or very slow.

Pollutant Minimization Program (PMP)

PMP means waste minimization and pollution prevention actions that include, but are not limited to, product substitution, waste stream recycling, alternative waste management methods, and education of the public and businesses. The goal of the PMP shall be to reduce all potential sources of a priority pollutant(s) through pollutant minimization (control) strategies, including pollution prevention measures as appropriate, to maintain the effluent concentration at or below the water quality-based effluent limitation. Pollution prevention measures may be particularly appropriate for persistent bioaccumulative priority pollutants where there is evidence that beneficial uses are being impacted. The Los Angeles Water Board may consider cost effectiveness when establishing the requirements of a PMP. The completion and implementation of a Pollution Prevention Plan, if required pursuant to Water Code section 13263.3(d), shall be considered to fulfill the PMP requirements.

Pollution Prevention

Pollution Prevention means any action that causes a net reduction in the use or generation of a hazardous substance or other pollutant that is discharged into water and includes, but is not limited to, input change, operational improvement, production process change, and product reformulation (as defined in Water Code section 13263.3). Pollution prevention does not include actions that merely shift a pollutant in wastewater from one environmental medium to another environmental medium, unless clear environmental benefits of such an approach are identified to the satisfaction of the State Water Resources Control Board (State Water Board) or Los Angeles Water Board.

Reporting Level (RL)

The RL is the ML (and its associated analytical method) chosen by the Discharger for reporting and compliance determination from the MLs included in this Order, including an additional factor if applicable as discussed herein. The MLs included in this Order correspond to approved analytical methods for reporting a sample result that are selected by the Los Angeles Water Board either from Appendix 4 of the SIP in accordance with section 2.4.2 of the SIP or established in accordance with section 2.4.3 of the SIP. The ML is based on the proper application of method-based analytical procedures for sample preparation and the absence of any matrix interferences. Other factors may be applied to the ML depending on the specific sample preparation steps employed. For example, the treatment typically applied in cases where there are matrix-effects is to dilute the sample or sample aliquot by a factor of ten. In such cases, this additional factor must be applied to the ML in the computation of the RL.

Source of Drinking Water

Any water designated as municipal or domestic supply (MUN) in a Los Angeles Water Board Basin Plan.

Standard Deviation (σ)

Standard Deviation is a measure of variability that is calculated as follows:

$$\sigma = (\sum[(x - \mu)^2]/(n - 1))^{0.5}$$

where: x is the observed value; μ is the arithmetic mean of the observed values; and n is the number of samples.

Statistical Threshold Value (STV)

The STV for the bacteria water quality objectives is a set value that approximates the 90th percentile of the water quality distribution of a bacterial population.

Toxicity Reduction Evaluation (TRE)

TRE is a study conducted in a step-wise process designed to identify the causative agents of effluent or ambient toxicity, isolate the sources of toxicity, evaluate the effectiveness of toxicity control options, and then confirm the reduction in toxicity. The first steps of the TRE consist of the collection of data relevant to the toxicity, including additional toxicity testing, and an evaluation of facility operations and maintenance practices, and best management practices. A Toxicity Identification Evaluation (TIE) may be required as part of the TRE, if appropriate. (A TIE is a set of procedures to identify the specific chemical(s) responsible for toxicity. These procedures are performed in three phases (characterization, identification, and confirmation) using aquatic organism toxicity tests.)

Trash

All improperly discarded solid material from any production, manufacturing, or processing operation including, but not limited to, products, product packaging, or containers constructed of plastic, steel, aluminum, glass, paper, or other synthetic or natural materials.

ACRONYMS AND ABBREVIATIONS

AMEL	Average Monthly Effluent Limit
B	Background Concentration
BAT	Best Available Technology Economically Achievable
Basin Plan	<i>Water Quality Control Plan for the Coastal Watersheds of Los Angeles and Ventura Counties</i>
BCT	Best Conventional Pollutant Control Technology
BMP	Best Management Practices
BMPP	Best Management Practices Plan
BPJ	Best Professional Judgment
BOD	Biochemical Oxygen Demand 5-day @ 20°C
BPT	Best Practicable Treatment Control Technology
C	Water Quality Objective
CCR	California Code of Regulations
CEQA	California Environmental Quality Act
CFR	Code of Federal Regulations
CTR	California Toxics Rule
CV	Coefficient of Variation
CWA	Clean Water Act
CWC	California Water Code
Discharger	TFX Aviation, Inc.
DMR	Discharge Monitoring Report
DNQ	Detected but Not Quantified
ELAP	State Water Resources Control Board, Drinking Water Division, Laboratory Accreditation Program
ELG	Effluent Limitations, Guidelines and Standards
Facility	TFX Aviation, Inc., Facility
gpd	gallons per day
IC	Inhibition Coefficient
IC15	Concentration at which the organism is 15% inhibited
IC25	Concentration at which the organism is 25% inhibited
IC40	Concentration at which the organism is 40% inhibited
IC50	Concentration at which the organism is 50% inhibited
IWC	In-stream Waste Concentration
LA	Load Allocations
LOEC	Lowest Observed Effect Concentration
µg/L	micrograms per Liter
mg/L	milligrams per Liter
ML	Minimum Level
MMEL	Median Monthly Effluent Limitation
MPN	Most Probable Number
MRP	Monitoring and Reporting Program
ND	Not Detected
NOEC	No Observable Effect Concentration
NPDES	National Pollutant Discharge Elimination System

NSPS	New Source Performance Standards
NTR	National Toxics Rule
OAL	Office of Administrative Law
	PMEL Proposed Maximum Daily Effluent Limitation
PMP	Pollutant Minimization Plan
POTW	Publicly Owned Treatment Works
QA	Quality Assurance
QAPP	Quality Assurance Project Plan
QA/QC	Quality Assurance/Quality Control
Ocean Plan	<i>Water Quality Control Plan for Ocean Waters of California</i>
Los Angeles Water Board	California Regional Water Quality Control Board, Los Angeles Region
RPA	Reasonable Potential Analysis
SCP	Spill Contingency Plan
SIP	State Implementation Policy (<i>Policy for Implementation of Toxics Standards for Inland Surface Waters, Enclosed Bays, and Estuaries of California</i>)
SMR	Self Monitoring Reports
State Water Board	California State Water Resources Control Board
SWPPP	Stormwater Pollution Prevention Plan
TAC	Test Acceptability Criteria
Thermal Plan	<i>Water Quality Control Plan for Control of Temperature in the Coastal and Interstate Water and Enclosed Bays and Estuaries of California</i>
TIE	Toxicity Identification Evaluation
TMDL	Total Maximum Daily Load
TOC	Total Organic Carbon
TRE	Toxicity Reduction Evaluation
TSD	Technical Support Document
TSS	Total Suspended Solid
TST	Test of Significant Toxicity
TUc	Chronic Toxicity Unit
USC	United States Code
U.S. EPA	United States Environmental Protection Agency
WDR	Waste Discharge Requirements
WET	Whole Effluent Toxicity
WLA	Waste Load Allocation
WQBELs	Water Quality-Based Effluent Limitations
WQS	Water Quality Standards
%	Percent

ATTACHMENT B1 – SITE LOCATION MAP

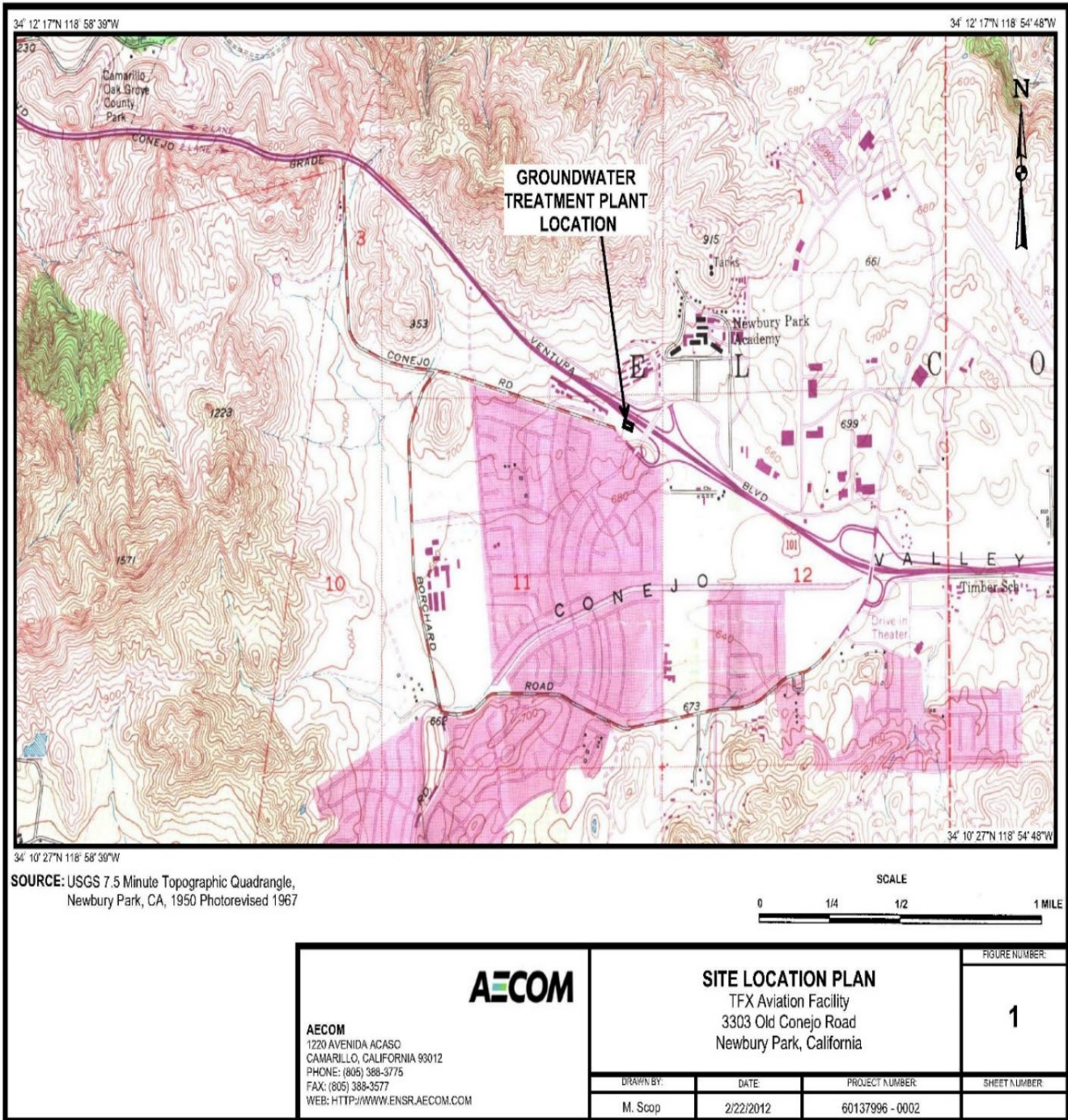

ATTACHMENT B2 – OUTFALL EFF- 001 LOCATION

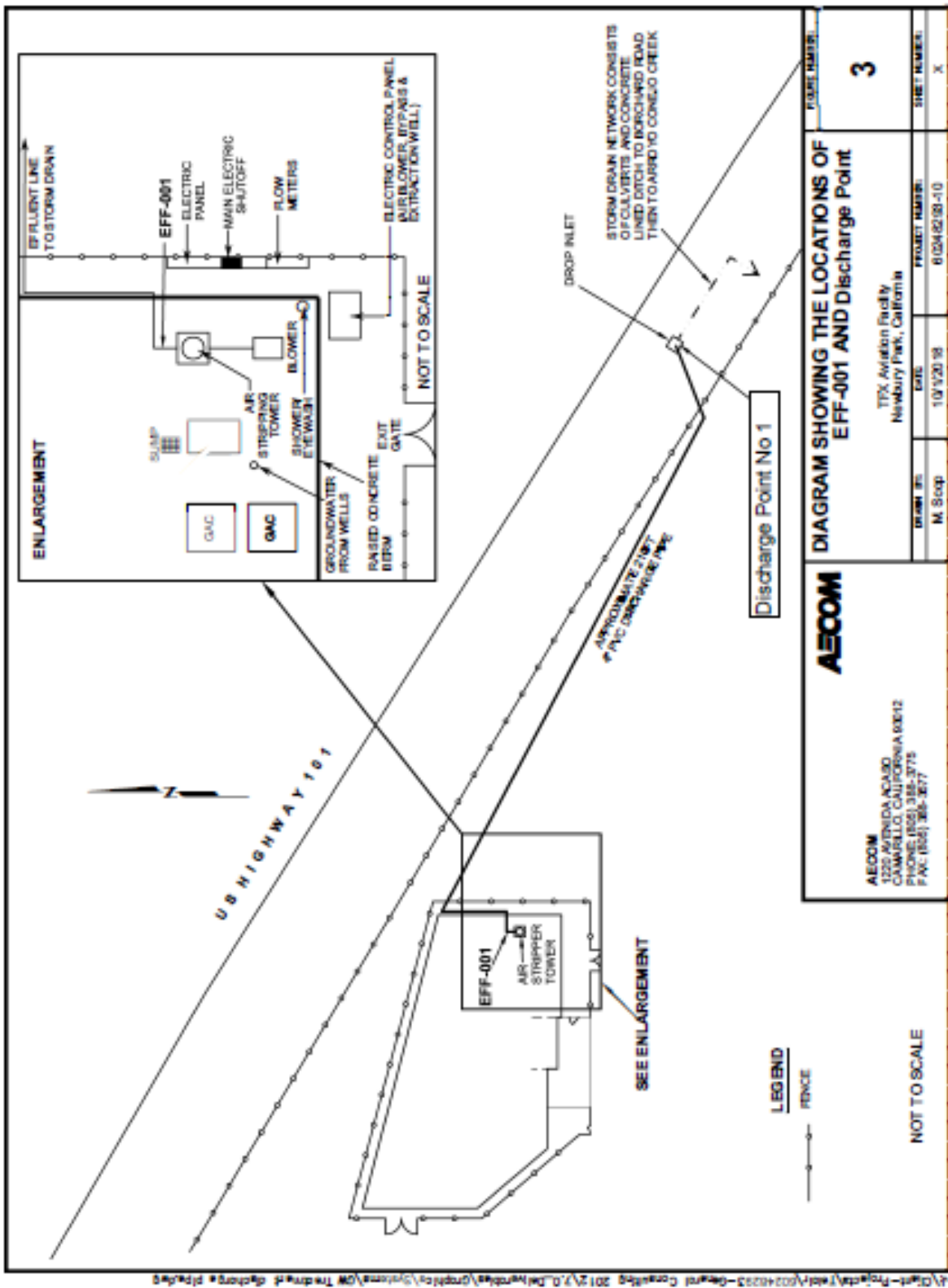

AECOM		DIAGRAM SHOWING THE LOCATIONS OF EFF-001 AND Discharge Point	
AECOM 3225 AVENIDA CALSO CAMARILLO, CALIFORNIA 93012 PHONE: (805) 385-3775 FAX: (805) 385-8777		DATE: 10/1/2018	PROJECT NUMBER: 6102402100-10
DESIGN BY: M. Scop	DATE: 10/1/2018	SHEET NUMBER: 3	SHEET TOTAL: X

ATTACHMENT C1 – FLOW SCHEMATIC

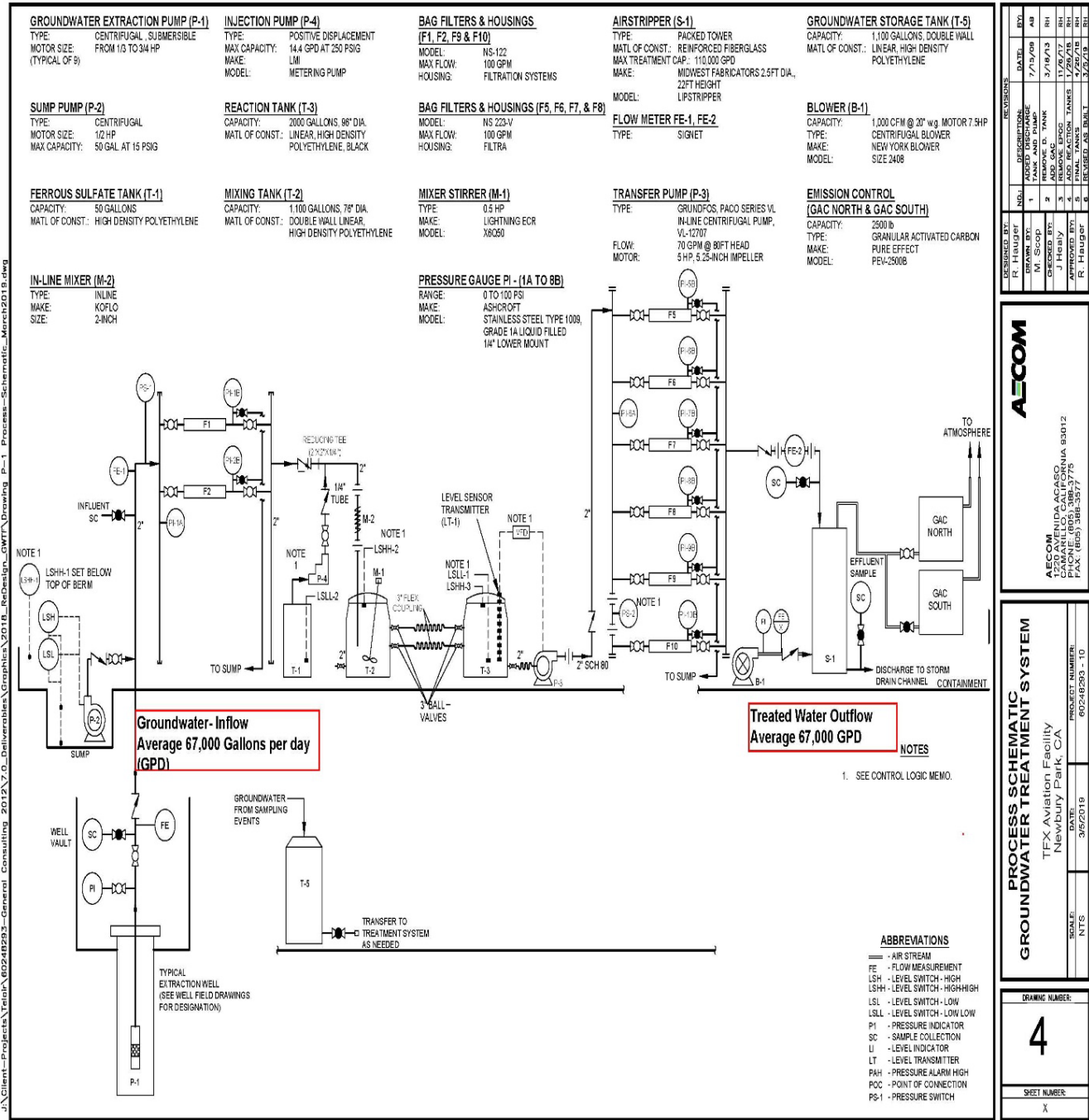

ATTACHMENT C2 – GROUNDWATER TREATMENT FACILITY DIAGRAM

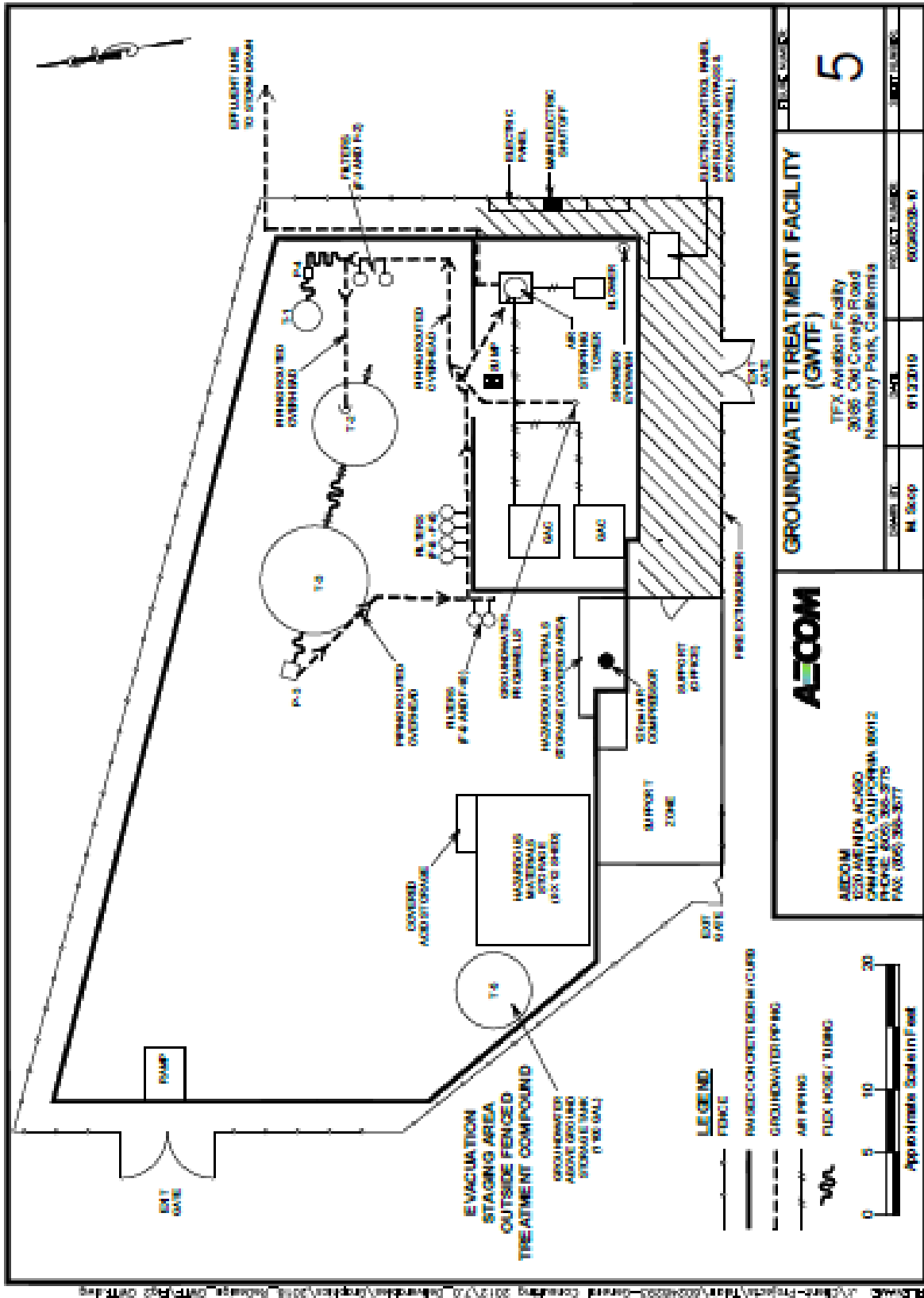

	GROUNDWATER TREATMENT FACILITY (GNTF)		5
	TFX Aviation Facility 3086 Old Conango Road Newbury Park, California		
AECOM 1520 AVENUE ACACSO OAKLAND, CALIFORNIA 94612 PHONE: (415) 363-3775 FAX: (415) 363-3777	DRAWN BY: M. Sloop	PROJECT NUMBER: 6122010	SHEET NUMBER: 6122010-10

ATTACHMENT D – STANDARD PROVISIONS

1. STANDARD PROVISIONS – PERMIT COMPLIANCE

1.1. Duty to Comply

- 1.1.1. The Discharger must comply with all the terms, requirements, and conditions of this Order. Any noncompliance constitutes a violation of the Clean Water Act (CWA) and the California Water Code and is grounds for enforcement action; permit termination, revocation and reissuance, or modification; denial of a permit renewal application; or a combination thereof. (Title 40 of the Code of Federal Regulations (40 CFR) § 122.41(a); California Water Code (CWC), §§ 13261, 13263, 13265, 13268, 13000, 13001, 13304, 13350, 13385.)
- 1.1.2. The Discharger shall comply with effluent standards or prohibitions established under Section 307(a) of the CWA for toxic pollutants within the time provided in the regulations that establish these standards or prohibitions, even if this Order has not yet been modified to incorporate the requirement. (40 CFR § 122.41(a)(1).)

1.2. Need to Halt or Reduce Activity Not a Defense

It shall not be a defense for a Discharger in an enforcement action that it would have been necessary to halt or reduce the permitted activity in order to maintain compliance with the conditions of this Order. (40 CFR § 122.41(c).)

1.3. Duty to Mitigate

The Discharger shall take all reasonable steps to minimize or prevent any discharge in violation of this Order that has a reasonable likelihood of adversely affecting human health or the environment. (40 CFR § 122.41(d).)

1.4. Proper Operation and Maintenance

The Discharger shall at all times properly operate and maintain all facilities and systems of treatment and control (and related appurtenances) which are installed or used by the Discharger to achieve compliance with the conditions of this Order. Proper operation and maintenance also include adequate laboratory controls and appropriate quality assurance procedures. This provision requires the operation of backup or auxiliary facilities or similar systems that are installed by a Discharger only when necessary to achieve compliance with the conditions of this Order. (40 CFR § 122.41(e).)

1.5. Property Rights

- 1.5.1. This Order does not convey any property rights of any sort or any exclusive privileges. (40 CFR § 122.41(g).)
- 1.5.2. The issuance of this Order does not authorize any injury to persons or property or invasion of other private rights, or any infringement of state or local law or regulations. (40 CFR § 122.5(c).)

1.6. Inspection and Entry

The Discharger shall allow the Los Angeles Water Board, State Water Board, U.S. EPA, and/or their authorized representatives (including an authorized contractor acting as their representative), upon the presentation of credentials and other documents, as may

be required by law, to (33 U.S.C. § 1318(a)(B); 40 CFR § 122.41(i); CWC, §§ 13267, 13383):

- 1.6.1. Enter upon the Discharger's premises where a regulated facility or activity is located or conducted, or where records are kept under the conditions of this Order (33 U.S.C. § 1318(a)(B)(i); 40 CFR § 122.41(i)(1); CWC, §§ 13267, 13383);
- 1.6.2. Have access to and copy, at reasonable times, any records that must be kept under the conditions of this Order (33 U.S.C. § 1318(a)(B)(ii); 40 CFR § 122.41(i)(2); CWC, §§ 13267, 13383);
- 1.6.3. Inspect and photograph, at reasonable times, any facilities, equipment (including monitoring and control equipment), practices, or operations regulated or required under this Order (33 U.S.C. § 1318(a)(B)(ii); 40 CFR § 122.41(i)(3); CWC, §§ 13267, 13383); and
- 1.6.4. Sample or monitor, at reasonable times, for the purposes of assuring Order compliance or as otherwise authorized by the CWA or the Water Code, any substances or parameters at any location. (33 U.S.C. § 1318(a)(B); 40 CFR § 122.41(i)(4); CWC, §§ 13267, 13383.)

1.7. Bypass

1.7.1. Definitions

- a. "Bypass" means the intentional diversion of waste streams from any portion of a treatment facility. (40 CFR § 122.41(m)(1)(i).)
- b. "Severe property damage" means substantial physical damage to property, damage to the treatment facilities, which causes them to become inoperable, or substantial and permanent loss of natural resources that can reasonably be expected to occur in the absence of a bypass. Severe property damage does not mean economic loss caused by delays in production. (40 CFR § 122.41(m)(1)(ii).)

1.7.2. Bypass not exceeding limitations. The Discharger may allow any bypass to occur which does not cause exceedances of effluent limitations, but only if it is for essential maintenance to assure efficient operation. These bypasses are not subject to the provisions listed in Standard Provisions – Permit Compliance 1.7.3, 1.7.4, and 1.7.5 below. (40 CFR § 122.41(m)(2).)

1.7.3. Prohibition of bypass. Bypass is prohibited, and the Los Angeles Water Board may take enforcement action against a Discharger for bypass, unless (40 CFR § 122.41(m)(4)(i)):

- a. Bypass was unavoidable to prevent loss of life, personal injury, or severe property damage (40 CFR § 122.41(m)(4)(i)(A));
- b. There were no feasible alternatives to the bypass, such as the use of auxiliary treatment facilities, retention of untreated wastes, or maintenance during normal periods of equipment downtime. This condition is not satisfied if adequate back up equipment should have been installed in the exercise of reasonable engineering judgment to prevent a bypass that occurred during

normal periods of equipment downtime or preventive maintenance (40 CFR § 122.41(m)(4)(i)(B)); and

- c. The Discharger submitted notice to the Los Angeles Water Board as required under Standard Provisions – Permit Compliance 1.7.5 below. (40 CFR § 122.41(m)(4)(i)(C).)

1.7.4. The Los Angeles Water Board may approve an anticipated bypass, after considering its adverse effects, if the Los Angeles Water Board determines that it will meet the three conditions listed in Standard Provisions – Permit Compliance 1.7.3 above. (40 CFR § 122.41(m)(4)(ii).)

1.7.5. Notice

- a. Anticipated bypass. If the Discharger knows in advance of the need for a bypass, it shall submit prior notice, if possible at least 10 days before the date of the bypass. As of December 21, 2023, all notices must be submitted electronically to the initial recipient defined in Standard Provisions – Reporting 5.10 below. Notices shall comply with 40 CFR part 3, 40 CFR section 122.22, and 40 CFR part 127. (40 CFR § 122.41(m)(3)(i).)
- b. Unanticipated bypass. The Discharger shall submit a notice of an unanticipated bypass as required in Standard Provisions - Reporting 5.5 below (24-hour notice). As of December 21, 2023, all notices must be submitted electronically to the initial recipient defined in Standard Provisions – Reporting 5.10 below. Notices shall comply with 40 CFR part 3, 40 CFR section 122.22, and 40 CFR part 127. (40 CFR § 122.41(m)(3)(ii).)

1.8. Upset

Upset means an exceptional incident in which there is unintentional and temporary noncompliance with technology-based permit effluent limitations because of factors beyond the reasonable control of the Discharger. An upset does not include noncompliance to the extent caused by operational error, improperly designed treatment facilities, inadequate treatment facilities, lack of preventive maintenance, or careless or improper operation. (40 CFR § 122.41(n)(1).)

1.8.1. Effect of an upset. An upset constitutes an affirmative defense to an action brought for noncompliance with such technology-based permit effluent limitations if the requirements of Standard Provisions – Permit Compliance 1.8.2 below are met. No determination made during administrative review of claims that noncompliance was caused by upset, and before an action for noncompliance, is final administrative action subject to judicial review. (40 CFR § 122.41(n)(2).)

1.8.2 Conditions necessary for a demonstration of upset. A Discharger who wishes to establish the affirmative defense of upset shall demonstrate, through properly signed, contemporaneous operating logs or other relevant evidence that (40 CFR § 122.41(n)(3)):

- a. An upset occurred and that the Discharger can identify the cause(s) of the upset (40 CFR § 122.41(n)(3)(i));

- b. The permitted facility was, at the time, being properly operated (40 CFR § 122.41(n)(3)(ii));
- c. The Discharger submitted notice of the upset as required in Standard Provisions – Reporting 5.5.2.2 below (24-hour notice) (40 CFR § 122.41(n)(3)(iii)); and
- d. The Discharger complied with any remedial measures required under Standard Provisions – Permit Compliance 1.3 above. (40 CFR § 122.41(n)(3)(iv).)

1.8.3. Burden of proof. In any enforcement proceeding, the Discharger seeking to establish the occurrence of an upset has the burden of proof. (40 CFR § 122.41(n)(4).)

2. STANDARD PROVISIONS – PERMIT ACTION

2.1. General

This Order may be modified, revoked and reissued, or terminated for cause. The filing of a request by the Discharger for modification, revocation and reissuance, or termination, or a notification of planned changes or anticipated noncompliance does not stay any Order condition. (40 CFR § 122.41(f).)

2.2. Duty to Reapply

If the Discharger wishes to continue an activity regulated by this Order after the expiration date of this Order, the Discharger must apply for and obtain a new permit. (40 CFR § 122.41(b).)

2.3. Transfers

This Order is not transferable to any person except after notice to the Los Angeles Water Board. The Los Angeles Water Board may require modification or revocation and reissuance of the Order to change the name of the Discharger and incorporate such other requirements as may be necessary under the CWA and the Water Code. (40 CFR §§ 122.41(l)(3), 122.61.)

3. STANDARD PROVISIONS – MONITORING

3.1. Samples and measurements taken for the purpose of monitoring shall be representative of the monitored activity. (40 CFR § 122.41(j)(1).)

3.2. Monitoring must be conducted according to test procedures approved under 40 CFR part 136 for the analyses of pollutants unless another method is required under 40 CFR chapter 1, subchapter N. Monitoring must be conducted according to sufficiently sensitive test methods approved under 40 CFR part 136 for the analysis of pollutants or pollutant parameters or as required under 40 CFR chapter 1, subchapter N. For the purposes of this paragraph, a method is sufficiently sensitive when:

3.2.1. The method minimum level (ML) is at or below the level of the most stringent effluent limitation established in the permit for the measured pollutant or pollutant parameter, and either the method ML is at or below the level of the most stringent applicable water quality criterion for the measured pollutant or pollutant parameter or the method ML is above the applicable water quality criterion but the amount of the pollutant or pollutant parameter in the facility's discharge is high enough that the method detects and quantifies the level of the pollutant or pollutant parameter in the discharge; or

3.2.2. The method has the lowest ML of the analytical methods approved under 40 CFR part 136 or required under 40 CFR chapter 1, subchapter N for the measured pollutant or pollutant parameter. In the case of pollutants or pollutant parameters for which there are no approved methods under 40 CFR part 136 or otherwise required under 40 CFR chapter 1, subchapter N, monitoring must be conducted according to a test procedure specified in this Order for such pollutants or pollutant parameters. (40 CFR §§ 122.21(e)(3), 122.41(j)(4), 122.44(i)(1)(iv).)

4. STANDARD PROVISIONS – RECORDS

4.1. The Discharger shall retain records of all monitoring information, including all calibration and maintenance records and all original strip chart recordings for continuous monitoring instrumentation, copies of all reports required by this Order, and records of all data used to complete the application for this Order, for a period of at least three (3) years from the date of the sample, measurement, report or application. This period may be extended by request of the Los Angeles Water Board Executive Officer at any time. (40 CFR § 122.41(j)(2).)

4.2. Records of monitoring information shall include:

- 4.2.1. The date, exact place, and time of sampling or measurements (40 CFR § 122.41(j)(3)(i));
- 4.2.2. The individual(s) who performed the sampling or measurements (40 CFR § 122.41(j)(3)(ii));
- 4.2.3. The date(s) analyses were performed (40 CFR § 122.41(j)(3)(iii));
- 4.2.4. The individual(s) who performed the analyses (40 CFR § 122.41(j)(3)(iv));
- 4.2.5. The analytical techniques or methods used (40 CFR § 122.41(j)(3)(v)); and
- 4.2.6. The results of such analyses. (40 CFR § 122.41(j)(3)(vi).)

4.3. Claims of confidentiality for the following information will be denied (40 CFR § 122.7(b)):

- 4.3.1. The name and address of any permit applicant or Discharger (40 CFR § 122.7(b)(1)); and
- 4.3.2. Permit applications and attachments, permits and effluent data. (40 CFR § 122.7(b)(2).)

5. STANDARD PROVISIONS – REPORTING

5.1. Duty to Provide Information

The Discharger shall furnish to the Los Angeles Water Board, State Water Board, or U.S. EPA within a reasonable time, any information which the Los Angeles Water Board, State Water Board, or U.S. EPA may request to determine whether cause exists for modifying, revoking and reissuing, or terminating this Order or to determine compliance with this Order. Upon request, the Discharger shall also furnish to the Los Angeles Water Board, State Water Board, or U.S. EPA copies of records required to be kept by this Order. (40 CFR § 122.41(h); CWC, §§ 13267, 13383.)

5.2. Signatory and Certification Requirements

- 5.2.1. All applications, reports, or information submitted to the Los Angeles Water Board, State Water Board, and/or U.S. EPA shall be signed and certified in accordance with Standard Provisions – Reporting 5.2.2, 5.2.3, 5.2.4, 5.2.5, and 5.2.6 below. (40 CFR § 122.41(k).)
- 5.2.2. All permit applications shall be signed by either a principal executive officer or ranking elected official. For purposes of this provision, a principal executive officer of a federal agency includes: (i) the chief executive officer of the agency, or (ii) a senior executive officer having responsibility for the overall operations of a principal geographic unit of the agency (e.g., Regional Administrators of U.S. EPA). (40 CFR § 122.22(a)(3).)
- 5.2.3. All reports required by this Order and other information requested by the Los Angeles Water Board, State Water Board, or U.S. EPA shall be signed by a person described in Standard Provisions – Reporting 5.2.2 above, or by a duly authorized representative of that person. A person is a duly authorized representative only if:
- a. The authorization is made in writing by a person described in Standard Provisions – Reporting 5.2.2 above (40 CFR § 122.22(b)(1));
 - b. The authorization specifies either an individual or a position having responsibility for the overall operation of the regulated facility or activity such as the position of plant manager, operator of a well or a well field, superintendent, position of equivalent responsibility, or an individual or position having overall responsibility for environmental matters for the company. (A duly authorized representative may thus be either a named individual or any individual occupying a named position.) (40 CFR § 122.22(b)(2)); and
 - c. The written authorization is submitted to the Los Angeles Water Board and State Water Board. (40 CFR § 122.22(b)(3).)
- 5.2.4. If an authorization under Standard Provisions – Reporting 5.2.3 above is no longer accurate because a different individual or position has responsibility for the overall operation of the facility, a new authorization satisfying the requirements of Standard Provisions – Reporting 5.2.3 above must be submitted to the Los Angeles Water Board and State Water Board prior to or together with any reports, information, or applications, to be signed by an authorized representative. (40 CFR § 122.22(c).)
- 5.2.5. Any person signing a document under Standard Provisions – Reporting 5.2.2 or 5.2.3 above shall make the following certification:
- “I certify under penalty of law that this document and all attachments were prepared under my direction or supervision in accordance with a system designed to assure that qualified personnel properly gather and evaluate the information submitted. Based on my inquiry of the person or persons who manage the system or those persons directly responsible for gathering the information, the information submitted is, to the best of my knowledge and

belief, true, accurate, and complete. I am aware that there are significant penalties for submitting false information, including the possibility of fine and imprisonment for knowing violations.” (40 CFR § 122.22(d).)

- 5.2.6. Any person providing the electronic signature for documents described in Standard Provisions – 5.2.1, 5.2.2, or 5.2.3 that are submitted electronically shall meet all relevant requirements of Standard Provisions – Reporting 5.2, and shall ensure that all relevant requirements of 40 CFR part 3 (Cross-Media Electronic Reporting) and 40 CFR part 127 (NPDES Electronic Reporting Requirements) are met for that submission. (40 CFR § 122.22(e).)

5.3. Monitoring Reports

- 5.3.1. Monitoring results shall be reported at the intervals specified in the Monitoring and Reporting Program (Attachment E) in this Order. (40 CFR § 122.41(l)(4).)
- 5.3.2. Monitoring results must be reported on a Discharge Monitoring Report (DMR) form or forms provided or specified by the Los Angeles Water Board or State Water Board. As of December 21, 2016, all reports and forms must be submitted electronically to the initial recipient defined in Standard Provisions – Reporting 5.10 and comply with 40 CFR part 3, 40 CFR section 122.22, and 40 CFR part 127. (40 CFR § 122.41(l)(4)(i).)
- 5.3.3. If the Discharger monitors any pollutant more frequently than required by this Order using test procedures approved under 40 CFR part 136, or another method required for an industry-specific waste stream under 40 CFR chapter 1, subchapter N, the results of such monitoring shall be included in the calculation and reporting of the data submitted in the DMR or reporting form specified by the Los Angeles Water Board or State Water Board. (40 CFR § 122.41(l)(4)(ii).)
- 5.3.4. Calculations for all limitations, which require averaging of measurements, shall utilize an arithmetic mean unless otherwise specified in this Order. (40 CFR § 122.41(l)(4)(iii).)

5.4. Compliance Schedules

Reports of compliance or noncompliance with, or any progress reports on, interim and final requirements contained in any compliance schedule of this Order, shall be submitted no later than 14 days following each schedule date. (40 CFR § 122.41(l)(5).)

5.5. Twenty-Four Hour Reporting

- 5.5.1. The Discharger shall report any noncompliance which may endanger health or the environment. Any information shall be provided orally within 24 hours from the time the Discharger becomes aware of the circumstances. A report shall also be provided within five (5) days of the time the Discharger becomes aware of the circumstances. The report shall contain a description of the noncompliance and its cause; the period of noncompliance, including exact dates and times, and if the noncompliance has not been corrected, the anticipated time it is expected to continue; and steps taken or planned to reduce, eliminate, and prevent reoccurrence of the noncompliance.

For noncompliance events related to combined sewer overflows, sanitary sewer overflows, or bypass events, these reports must include the data described above (with the exception of time of discovery) as well as the type of event (i.e., combined sewer overflow, sanitary sewer overflow, or bypass event), type of overflow structure (e.g., manhole, combined sewer overflow outfall), discharge volume untreated by the treatment works treating domestic sewage, types of human health and environmental impacts of the event, and whether the noncompliance was related to wet weather.

As of December 21, 2023, all reports related to combined sewer overflows, sanitary sewer overflows, or bypass events must be submitted must be submitted electronically to the initial recipient defined in Standard Provisions – Reporting 5.10 The reports shall comply with 40 CFR part 3, 40 C.F.R. section 122.22, and 40 CFR part 127. The Los Angeles Water Board may also require the Discharger to electronically submit reports not related to combined sewer overflows, sanitary sewer overflows, or bypass events under this section. (40 CFR § 122.41(l)(6)(i).)

5.5.2. The following shall be included as information that must be reported within 24 hours:

- a. Any unanticipated bypass that exceeds any effluent limitation in this Order. (40 CFR § 122.41(l)(6)(ii)(A).)
- b. Any upset that exceeds any effluent limitation in this Order. (40 CFR § 122.41(l)(6)(ii)(B).)

5.5.3. The Los Angeles Water Board may waive the above required written report on a case-by-case basis if an oral report has been received within 24 hours. (40 CFR § 122.41(l)(6)(ii)(B).)

5.6. Planned Changes

The Discharger shall give notice to the Los Angeles Water Board as soon as possible of any planned physical alterations or additions to the permitted facility. Notice is required under this provision only when (40 CFR § 122.41(l)(1)):

- 5.6.1. The alteration or addition to a permitted facility may meet one of the criteria for determining whether a facility is a new source in section 122.29(b) (40 CFR § 122.41(l)(1)(i)); or
- 5.6.2. The alteration or addition could significantly change the nature or increase the quantity of pollutants discharged. This notification applies to pollutants that are not subject to effluent limitations in this Order. (40 CFR § 122.41(l)(1)(ii).)
- 5.6.3. The alteration or addition results in a significant change nature or increase the quantity of pollutants discharged. This notification applies to pollutants that are subject neither to effluent limitations in this Order nor to notification requirements under section 122.42(a)(1) (see Additional Provisions—Notification Levels 7.1.1). (40 CFR § 122.41(l)(1)(ii).)

5.7. Anticipated Noncompliance

The Discharger shall give advance notice to the Los Angeles Water Board of any planned changes in the permitted facility or activity that may result in noncompliance with this Order's requirements. (40 CFR § 122.41(l)(2).)

5.8. Other Noncompliance

The Discharger shall report all instances of noncompliance not reported under Standard Provisions – Reporting 5.3, 5.4, and 5.5 above at the time monitoring reports are submitted. The reports shall contain the information listed in Standard Provision – Reporting 5.5 above. For noncompliance events related to combined sewer overflows, sanitary sewer overflows, or bypass events, these reports shall contain the information described in Standard Provision – Reporting 5.5 and the applicable required data in appendix A to 40 CFR part 127. The Los Angeles Water Board may also require the Discharger to electronically submit reports not related to combined sewer overflows, sanitary sewer overflows, or bypass events under this section. (40 CFR § 122.41(l)(7).)

5.9. Other Information

When the Discharger becomes aware that it failed to submit any relevant facts in a permit application, or submitted incorrect information in a permit application or in any report to the Los Angeles Water Board, State Water Board, or U.S. EPA, the Discharger shall promptly submit such facts or information. (40 CFR § 122.41(l)(8).)

5.10. Initial Recipient for Electronic Reporting Data

The owner, operator, or the duly authorized representative is required to electronically submit NPDES information specified in appendix A to 40 CFR part 127 to the initial recipient defined in 40 CFR section 127.2(b). U.S. EPA will identify and publish the list of initial recipients on its website and in the Federal Register, by state and by NPDES data group [see 40 CFR section 127.2(c)]. U.S. EPA will update and maintain this listing. (40 CFR § 122.41(l)(9).)

6. STANDARD PROVISIONS – ENFORCEMENT

- 6.1. The Los Angeles Water Board is authorized to enforce the terms of this permit under several provisions of the Water Code, including, but not limited to, sections 13268, 13385, 13386, and 13387.
- 6.2. The CWA provides that any person who violates section 301, 302, 306, 307, 308, 318 or 405 of the CWA, or any permit condition or limitation implementing any such sections in a permit issued under section 402, or any requirement imposed in a pretreatment program approved under sections 402(a)(3) or 402(b)(8) of the CWA, is subject to a civil penalty not to exceed \$25,000 per day for each violation. The CWA provides that any person who *negligently* violates sections 301, 302, 306, 307, 308, 318, or 405 of the CWA, or any condition or limitation implementing any of such sections in a permit issued under section 402 of the CWA, or any requirement imposed in a pretreatment program approved under section 402(a)(3) or 402(b)(8) of the CWA, is subject to criminal penalties of \$2,500 to \$25,000 per day of violation, or imprisonment of not more than one year, or both. In the case of a second or subsequent conviction for a negligent violation, a person shall be subject to criminal penalties of not more than \$50,000 per day of violation, or by imprisonment of not more

than two years, or both. Any person who *knowingly* violates such conditions or limitations is subject to criminal penalties of \$5,000 to \$50,000 per day of violation, or imprisonment for not more than three years, or both. In the case of a second or subsequent conviction for a knowing violation, a person shall be subject to criminal penalties of not more than \$100,000 per day of violation, or imprisonment of not more than 6 years, or both. Any person who *knowingly* violates section 301, 302, 303, 306, 307, 308, 318 or 405 of the CWA, or any permit condition or limitation implementing any of such sections in a permit issued under section 402 of the CWA, and who knows at that time that he thereby places another person in imminent danger of death or serious bodily injury, shall, upon conviction, be subject to a fine of not more than \$250,000 or imprisonment of not more than 15 years, or both. In the case of a second or subsequent conviction for a knowing endangerment violation, a person shall be subject to a fine of not more than \$500,000 or by imprisonment of not more than 30 years, or both. An organization, as defined in section 309(c)(3)(B)(iii) of the CWA, shall, upon conviction of violating the imminent danger provision, be subject to a fine of not more than \$1,000,000 and can be fined up to \$2,000,000 for second or subsequent convictions (40 CFR § 122.41(a)(2); CWC section 13385 and 13387).

- 6.3. Any person may be assessed an administrative penalty by the Administrator of U.S. EPA, the Los Angeles Water Board, or State Water Board for violating section 301, 302, 306, 307, 308, 318 or 405 of this CWA, or any permit condition or limitation implementing any of such sections in a permit issued under section 402 of the CWA. Administrative penalties for Class I violations are not to exceed \$10,000 per violation, with the maximum amount of any Class I penalty assessed not to exceed \$25,000. Penalties for Class II violations are not to exceed \$10,000 per day for each day during which the violation continues, with the maximum amount of any Class II penalty not to exceed \$125,000. (40 CFR § 122.41(a)(3))
- 6.4. The CWA provides that any person who falsifies, tampers with, or knowingly renders inaccurate any monitoring device or method required to be maintained under this permit shall, upon conviction, be punished by a fine of not more than \$10,000, or by imprisonment for not more than two years, or both. If a conviction of a person is for a violation committed after a first conviction of such person under this paragraph, punishment is a fine of not more than \$20,000 per day of violation, or by imprisonment of not more than four years, or both. (40 CFR § 122.41(j)(5)).
- 6.5. The CWA provides that any person who knowingly makes any false statement, representation, or certification in any record or other document submitted or required to be maintained under this permit, including monitoring reports or reports of compliance or non-compliance shall, upon conviction, be punished by a fine of not more than \$10,000 per violation, or by imprisonment for not more than six months per violation, or by both. (40 CFR § 122.41(k)(2)).

7. ADDITIONAL PROVISIONS – NOTIFICATION LEVELS

7.1. Non-Municipal Facilities

Existing manufacturing, commercial, mining, and silvicultural Dischargers shall notify the Los Angeles Water Board as soon as they know or have reason to believe (40 CFR § 122.42(a)):

- 7.1.1. That any activity has occurred or will occur that would result in the discharge, on a routine or frequent basis, of any toxic pollutant that is not limited in this Order, if that discharge will exceed the highest of the following "notification levels" (40 CFR § 122.42(a)(1)):
 - a. 100 micrograms per liter ($\mu\text{g/L}$) (40 CFR § 122.42(a)(1)(i));
 - b. 200 $\mu\text{g/L}$ for acrolein and acrylonitrile; 500 $\mu\text{g/L}$ for 2,4 dinitrophenol and 2-methyl 4,6 dinitrophenol; and 1 milligram per liter (mg/L) for antimony (40 CFR § 122.42(a)(1)(ii));
 - c. Five (5) times the maximum concentration value reported for that pollutant in the Report of Waste Discharge (40 CFR § 122.42(a)(1)(iii)); or
 - d. The level established by the Los Angeles Water Board in accordance with section 122.44(f). (40 CFR § 122.42(a)(1)(iv).)
- 7.1.2. That any activity has occurred or will occur that would result in the discharge, on a non-routine or infrequent basis, of any toxic pollutant that is not limited in this Order, if that discharge will exceed the highest of the following "notification levels" (40 CFR § 122.42(a)(2)):
 - a. 500 micrograms per liter ($\mu\text{g/L}$) (40 CFR § 122.42(a)(2)(i));
 - b. 1 milligram per liter (mg/L) for antimony (40 CFR § 122.42(a)(2)(ii));
 - c. Ten (10) times the maximum concentration value reported for that pollutant in the Report of Waste Discharge (40 CFR § 122.42(a)(2)(iii)); or
 - d. The level established by the Regional Water Board in accordance with section 122.44(f). (40 CFR § 122.42(a)(2)(iv).)

ATTACHMENT E – MONITORING AND REPORTING PROGRAM (MRP) (CI NO. 9544)

TABLE OF CONTENTS

1. GENERAL MONITORING PROVISIONS2

2. MONITORING LOCATIONS.....5

3. INFLUENT MONITORING REQUIREMENTS5

 3.1. Monitoring Location INF-0016

4. EFFLUENT MONITORING REQUIREMENTS6

 4.1. Monitoring Location EFF-0016

5. CHRONIC WHOLE EFFLUENT TOXICITY TESTING REQUIREMENTS.....10

 5.1. Discharge In-stream Waste Concentration (IWC) for Chronic Toxicity10

 5.2. Sample Volume and Holding Time10

 5.3. Chronic Freshwater Species and Test Methods.....10

 5.4. Species Sensitivity Screening11

 5.5. Quality Assurance and Additional Requirements11

 5.6. Accelerated Monitoring Schedule for Maximum Daily Single Result: “Fail and % Effect
 ≥ 50”12

 5.7. Preparation of an Initial Investigation TRE Work Plan.....13

 5.8. Toxicity Identification Evaluation (TIE) and Toxicity Reduction Evaluation (TRE)
 Process13

 5.9. Reporting.....14

6. LAND DISCHARGE MONITORING REQUIREMENTS - (NOT APPLICABLE).....15

7. RECYCLING MONITORING REQUIREMENTS - (NOT APPLICABLE).....15

8. RECEIVING WATER MONITORING REQUIREMENTS15

 8.1. Surface Water - Monitoring Location RSW-00115

 8.2. Groundwater Monitoring - Not applicable.....17

9. REPORTING REQUIREMENTS17

 9.1. General Monitoring and Reporting Requirements17

 9.2. Self-Monitoring Reports (SMRs).....17

 9.3. Discharge Monitoring Reports (DMRs) - Not Applicable20

 9.4. Other Reports.....20

Tables

Table E-1. Monitoring Station Locations5

Table E-2. Influent Monitoring.....6

Table E-3. Effluent Monitoring7

Table E-4. U.S. EPA Methods and Test Acceptability Criteria.....12

Table E-5. Receiving Water Monitoring Requirements-RSW-00115

Table E-6. Monitoring Periods and Reporting Schedule18

ATTACHMENT E – MONITORING AND REPORTING PROGRAM (MRP) CI NO. 9544

Section 308(a) of the federal Clean Water Act (CWA) and sections 122.41(h), (j)-(l), 122.44(i), and 122.48 of title 40 of the Code of Federal Regulations (40 CFR) require that all NPDES permits specify monitoring and reporting requirements. Water Code section 13383 also authorizes the Los Angeles Water Board to establish monitoring, inspection, entry, reporting, and recordkeeping requirements. This MRP establishes monitoring, reporting, and recordkeeping requirements that implement the federal and California laws and/or regulations.

1. GENERAL MONITORING PROVISIONS

- 1.1. An effluent sampling station shall be established for Discharge Point No. 001 and shall be located where representative samples of that effluent can be obtained.
- 1.2. Effluent samples shall be taken downstream of any addition to treatment works and prior to mixing with the receiving waters.
- 1.3. The Los Angeles Water Board shall be notified in writing of any change in the sampling stations once established or in the methods for determining the quantities of pollutants in the individual waste streams.
- 1.4. Pollutants shall be analyzed using the analytical methods described in 40 CFR sections 136.3, 136.4, and 136.5; or where no methods are specified for a given pollutant, by methods approved by this Los Angeles Water Board or the State Water Resources Control Board (State Water Board).
- 1.5. Laboratories analyzing effluent samples and receiving water samples shall be certified by the State Water Board, Division of Drinking Water (DDW) Environmental Laboratory Accreditation Program (ELAP) in accordance with the provision of Water Code section 13176, or approved by the Executive Officer and must include quality assurance/quality control (QA/QC) data in their reports. A copy of the laboratory certification shall be provided each time a new certification and/or renewal of the certification is obtained from ELAP.
- 1.6. For any analyses performed for which no procedure is specified in the United States Environmental Protection Agency (U.S. EPA) guidelines, or in the MRP, the constituent or parameter analyzed, and the method or procedure used must be specified in the monitoring report.
- 1.7. Each monitoring report must affirm in writing that *“all analyses were conducted at a laboratory certified for such analyses by the State Water Resources Control Board, Division of Drinking Water, or approved by the Executive Officer and in accordance with current U.S. EPA guideline procedures or as specified in this Monitoring and Reporting Program.”*
- 1.8. The monitoring reports shall specify the analytical method used, the Method Detection Limit (MDL), and the Minimum Level (ML) for each pollutant. For the purpose of reporting compliance with numerical limitations, performance goals, and receiving water limitations, analytical data shall be reported by one of the following methods, as appropriate:
 - 1.8.1. An actual numerical value for sample results greater than or equal to the ML; or

- 1.8.2. "Detected, but Not Quantified (DNQ)" if results are greater than or equal to the laboratory's MDL but less than the ML; or,
- 1.8.3. "Not-Detected (ND)" for sample results less than the laboratory's MDL with the MDL indicated for the analytical method used.

Analytical data reported as "less than" for the purpose of reporting compliance with permit limitations shall be the same or lower than the permit limit(s) established for the given parameter.

Current MLs are those published by the State Water Board in the *Policy for the Implementation of Toxics Standards for Inland Surface Waters, Enclosed Bays, and Estuaries of California* (State Implementation Policy or SIP), February 24, 2005, Appendix 4.

- 1.9. The MLs employed for effluent analyses to determine compliance with effluent limitations shall be lower than the effluent limitations established in this Order for a given parameter as per the 40 CFR parts 122 and 136; *Use of Sufficiently Sensitive Test Methods for Permit Applications and Reporting*. If the ML value is not below the effluent limitation, then the lowest ML value and its associated analytical method shall be selected for compliance purposes. At least once a year, the Discharger shall submit a list of the analytical methods employed for each test and associated laboratory QA/QC procedures.
- 1.10. The MLs employed for effluent analyses not associated with determining compliance with effluent limitations in this Order shall be lower than the lowest applicable water quality objective, for a given parameter as per 40 CFR parts 122 and 136; *Use of Sufficiently Sensitive Test Methods for Permit Applications and Reporting*. Water quality objectives for parameters may be found in Chapter 3 of the Basin Plan and the CTR (40 CFR section 131.38). If the ML value is not below the water quality objective, then the lowest ML value and its associated analytical method shall be selected for compliance purposes. At least once a year, the Discharger shall submit a list of the analytical methods employed for each test, the associated laboratory QA/QC procedures, reporting levels (RLs), and MDLs.

The Los Angeles Water Board, in consultation with the State Water Board Quality Assurance Program, shall establish a ML that is not contained in Appendix 4 of the SIP to be included in the Discharger's permit in any of the following situations:

- 1.10.1. When the pollutant under consideration is not included in Appendix 4 of the SIP;
- 1.10.2. When the Discharger and Los Angeles Water Board agree to include in the permit a test method that is more sensitive than that specified in part 136 (revised August 28, 2017);
- 1.10.3. When the Discharger agrees to use an ML that is lower than that listed in Appendix 4 of the SIP;
- 1.10.4. When the Discharger demonstrates that the calibration standard matrix is sufficiently different from that used to establish the ML in Appendix 4 of the SIP, and proposes an appropriate ML for their matrix; or,

- 1.10.5. When the Discharger uses a method whose quantification practices are not consistent with the definition of an ML. Examples of such methods are the U.S. EPA-approved method 1613 for dioxins and furans, method 1624 for volatile organic substances, and method 1625 for semi-volatile organic substances. In such cases, the Discharger, the Los Angeles Water Board, and the State Water Board shall agree on a lowest quantifiable limit and that limit will substitute for the ML for reporting and compliance determination purposes,
- 1.11. Water/wastewater samples must be analyzed within allowable holding time limits as specified in 40 CFR section 136.3. All QA/QC items must be run on the same dates the samples were actually analyzed, and the results shall be reported in the Los Angeles Water Board format, when it becomes available, and submitted with the laboratory reports. Proper chain of custody procedures must be followed, and a copy of the chain of custody shall be submitted with the report.
- 1.12. Field analyses with short sample holding time such as pH, total chlorine residual, and temperature, may be performed using properly calibrated and maintained portable instruments by trained personnel acting on the Discharger's behalf, using methods in accordance with 40 CFR part 136. All field instruments must be calibrated per manufacturer's instructions. A manual containing the standard operating procedures for all field analyses, including records of personnel proficiency, training, instruments calibration and maintenance, and quality control procedures shall be maintained onsite, and shall be available for inspection by Los Angeles Water Board staff. Information including instrument calibration, time of sample collection, time of analysis, name of analyst, quality assurance/quality control data, and measurement values shall be clearly documented during each field analysis and submitted to the Los Angeles Water Board as part of the corresponding regular monitoring report.
- 1.13. All analyses shall be accompanied by the chain of custody, including but not limited to date and time of sampling, sample identification, and name of person who performed sampling, date of analysis, name of person who performed analysis, QA/QC data, method detection limits, analytical methods, copy of laboratory certification, and a perjury statement executed by the person responsible for the laboratory.
- 1.14. The Discharger shall calibrate and perform maintenance procedures on all monitoring instruments to ensure accuracy of measurements or shall insure that both equipment activities will be conducted.
- 1.15. For parameters for which both average monthly and daily maximum limits are specified and the monitoring frequency is less than four times a month, the following shall apply. If an analytical result is greater than the average monthly limit, the Discharger shall collect four additional samples at approximately equal intervals during the month, until compliance with the average monthly limit has been demonstrated. All five analytical results shall be reported in the monitoring report for that month, or 45 days after results for the additional samples were received, whichever is later. In the event of noncompliance with an average monthly effluent limitation, the sampling frequency for that constituent shall be increased to weekly and shall continue at this level until compliance with the average monthly effluent limitation has been demonstrated. The Discharger shall provide for the approval of the Executive Officer a program to ensure future compliance with the average monthly limit.

1.16. In the event wastes are transported to a different disposal site during the reporting period, the following shall be reported in the monitoring report:

- 1.17.1. Types of wastes and quantity of each type;
- 1.17.2. Name and address for each hauler of wastes (or method of transport if other than by hauling); and
- 1.17.3. Location of the final point(s) of disposal for each type of waste.

If no wastes are transported off-site during the reporting period, a statement to that effect shall be submitted.

1.18. Each monitoring report shall state whether or not there was any change in the discharge as described in the Order during the reporting period.

2. MONITORING LOCATIONS

The Discharger shall establish the following monitoring locations to demonstrate compliance with the effluent limitations, discharge specifications, and other requirements in this Order:

Table E-1. Monitoring Station Locations

Discharge Point Name	Monitoring Location Name	Monitoring Location Description
---	INF-001	The influent sampling station shall be located where representative samples of the inflow to the treatment system can be obtained.
001	EFF-001	The effluent sampling station shall be located where representative samples of Discharge Point Number 001 can be obtained. Latitude: 34.1896° Longitude: -118.9399°
---	RSW-001	A receiving water sampling station shall be established upstream from the discharge point of the storm drain to the receiving water, South Fork of Arroyo Conejo Creek. The sampling point shall be located where representative and safe monitoring can occur.

The North latitude and West longitude information in Table E-1 are approximate for administrative purposes.

3. INFLUENT MONITORING REQUIREMENTS

Influent monitoring is required to continue to screen potential constituents that may be present in the effluent of the groundwater treatment system.

3.1. Monitoring Location INF-001

Table E-2. Influent Monitoring

Parameter	Units	Sample Type	Minimum Sampling Frequency (Note a)	Required Analytical Test Method
Flow (Note b)	mgd	recorder	1/Day	---
Selenium, TR	µg/L	Grab or Composite	1/Year	Notes a and c
Phenolic Compounds (Chlorinated)	µg/L	Grab or Composite	1/Year	Notes a, c and e
Phenols	µg/L	Grab or Composite	1/Year	Notes a, c and f
1,4-Dioxane	µg/L	Grab	1/Year	Note c
Remaining Priority Pollutants	µg/L	Grab or Composite (Note g)	1/Permit Term	Notes c, d and h

Footnotes for Table E-2

- a. Monitoring shall be once per year (unless otherwise noted) for three years from the effective date of this permit, and if the concentration of any constituent is less than the water quality criteria, influent monitoring will be discontinued for that constituent. For the constituents with concentrations equal to or greater than the criteria, the monitoring frequency remains the same.
- b. Flow shall be recorded daily during each period of discharge. Periods of no flow shall also be reported.
- c. Pollutants shall be analyzed using the analytical methods described in 40 CFR part 136; for priority pollutants, the methods must meet the lowest MLs specified in Appendix 4 of the SIP. Where no methods are specified for a given pollutant, the methods must be approved by the Los Angeles Water Board or the State Water Board. If more than one analytical test method is listed for a given parameter, the Discharger must select a sufficiently sensitive method from the listed methods and corresponding ML necessary to demonstrate compliance with applicable effluent limitations.
- d. Mercury shall be analyzed using EPA method 1631E, per 40 CFR part 136.
- e. Chlorinated phenolic compounds are comprised of the following constituents from the CTR list of priority pollutants: 2-chlorophenol, 2,4-dichlorophenol, 3-methyl-4-chlorophenol, pentachlorophenol, and 2,4,6-trichlorophenol.
- f. Phenols are comprised of the following constituents from the CTR list of priority pollutants: phenol, 2,4-dimethylphenol, 2-methyl-4,6-dinitrophenol, 2,4-dinitrophenol, 2-nitrophenol, and 4-nitrophenol.
- g. However, grab samples **must** be collected for the analyses of the following parameters: bis(2-ethylhexyl)phthalate and volatile and semi-volatile organics.
- h. Priority Pollutants are those constituents referred to in 40 CFR section 401.15; a list of these pollutants is provided as Appendix A to 40 CFR part 423.

End of Footnotes for Table E-2

4. EFFLUENT MONITORING REQUIREMENTS

4.1. Monitoring Location EFF-001

The Discharger shall monitor the discharge of treated groundwater effluent at Monitoring Location EFF-001 as follows. If more than one analytical test method is listed

for a given parameter, the Discharger must select from the listed methods and corresponding minimum level:

Table E-3. Effluent Monitoring

Parameter	Units (Note a)	Sample Type	Minimum Sampling Frequency	Required Analytical Test Method
Flow (Note b)	mgd	recorder	1/Day	
Biochemical Oxygen Demand @20°C (BOD ₅ 20°C)	mg/L and lbs/day	Grab or Composite	1/Quarter	EPA Method 405.1
Oil and Grease	mg/L and lbs/day	Grab	1/Quarter	Note c
pH	standard unit	Grab	1/Month	Note c
Total Suspended Solids (TSS)	mg/L and lbs/day	Grab or Composite	1/Quarter	Note c
Settleable Solids	ml/L	Grab or Composite	1/Quarter	Note c
Turbidity	NTU	Grab or Composite	1/Quarter	Note c
Temperature	degree F	Grab	1/Month	Note c
Chemical Oxygen Demand (COD)	mg/L	Grab or Composite	2/Year	Note c
Boron	mg/L and lbs/day	Grab	1/Quarter	Note c
Chloride	mg/L and lbs/day	Grab	1/Quarter	Note c
Sulfate	mg/L and lbs/day	Grab	1/Quarter	Note c
Nitrogen (as NO ₂ + NO ₃)	mg/L and lbs/day	Grab or Composite	1/Quarter	Note c
Total Dissolved Solids (TDS)	mg/L and lbs/day	Grab	1/Quarter	Note c
Ammonia, Total (as N)	mg/L and lbs/day	Grab or Composite	1/Quarter	Note c
Sulfides	mg/L and lbs/day	Grab	1/Quarter	Note c
Phenolic Compounds (Chlorinated) (Note d)	µg/L and lbs/day	Grab	1/Quarter	Note c
Methyl Tertiary Butyl Ether (MTBE)	µg/L and lbs/day	Grab	1/Quarter	Note c
Tertiary Butyl Alcohol (TBA)	µg/L and lbs/day	Grab	1/Quarter	Note c
Chlorpyrifos	µg/L and lbs/day	Grab	1/Quarter	Note c
Diazinon	µg/L and lbs/day	Grab	1/Quarter	Note c
Phenol (Note e)	mg/L and lbs/day	Grab or Composite	1/Year	Note c
Methyl Ethyl Ketone (MEK)	µg/L and lbs/day	Grab	1/Year	Note c
Chronic Toxicity	Pass or Fail and % Effect	Grab or Composite	1/Year	Note f
<i>E. coli</i>	MPN or cfu/100 ml	Grab	2/Year	Note c

Parameter	Units (Note a)	Sample Type	Minimum Sampling Frequency	Required Analytical Test Method
Arsenic, Total Recoverable (TR)	µg/L and lbs/day	Grab or Composite	2/Year	Note c
Barium	µg/L and lbs/day	Grab or Composite	2/Year	Note c
Cadmium, TR	µg/L and lbs/day	Grab or Composite	2/Year	Note c
Chromium, Total	µg/L and lbs/day	Grab or Composite	1/Quarter	Note c
Chromium (VI)	µg/L and lbs/day	Grab or Composite	1/Quarter	Note c
Copper, TR	µg/L and lbs/day	Grab or Composite	1/Quarter	Note c
Lead, TR	µg/L and lbs/day	Grab or Composite	2/Year	Note c
Mercury, TR	µg/L and lbs/day	Grab or Composite	1/Quarter	Notes c and g
Nickel, TR	µg/L and lbs/day	Grab or Composite	1/Quarter	Note c
Selenium, TR	µg/L and lbs/day	Grab or Composite	1/Quarter	Note c
Silver, TR	µg/L and lbs/day	Grab or Composite	1/Quarter	Note c
Zinc, TR	µg/L and lbs/day	Grab or Composite	1/Year	Note c
Benzene	µg/L and lbs/day	Grab	1/Quarter	Note c
Ethylbenzene	µg/L and lbs/day	Grab	1/Quarter	Note c
Toluene	µg/L and lbs/day	Grab	1/Quarter	Note c
Xylene	µg/L and lbs/day	Grab	1/Quarter	Note c
Dichlorobromomethane	µg/L and lbs/day	Grab	1/Quarter	Note c
Carbon Tetrachloride	µg/L and lbs/day	Grab	1/Quarter	Note c
1,1-Dichloroethane	µg/L and lbs/day	Grab	1/Quarter	Note c
1,2-Dichloroethane	µg/L and lbs/day	Grab	1/Quarter	Note c
1,1-Dichloroethylene	µg/L and lbs/day	Grab	1/Quarter	Note c
Trans 1,2-Dichloroethylene	µg/L and lbs/day	Grab	1/Quarter	Note c
Cis 1,2-Dichloroethylene	µg/L and lbs/day	Grab	1/Quarter	Note c
Tetrachloroethylene	µg/L and lbs/day	Grab	1/Quarter	Note c
1,1,1-Trichloroethane	µg/L and lbs/day	Grab	2/Year	Note c
Trichloroethylene	µg/L and lbs/day	Grab	1/Quarter	Note c
Vinyl Chloride	µg/L and lbs/day	Grab	1/Quarter	Note c
Bis(2-Ethylhexyl) Phthalate	µg/L and lbs/day	Grab	1/Quarter (Note h)	Note c
Chlordane	µg/L and lbs/day	Grab or Composite	1/Quarter	Note c
4,4-DDD	µg/L and lbs/day	Grab or Composite	1/Quarter	Note c
4,4-DDE	µg/L and lbs/day	Grab or Composite	1/Quarter	Note c
4,4-DDT	µg/L and lbs/day	Grab or Composite	1/Quarter	Note c
Dieldrin	µg/L and lbs/day	Grab or Composite	1/Quarter	Note c
Polychlorinated Biphenyls (PCBs)	µg/L and lbs/day	Grab or Composite	1/Quarter	Note c
Toxaphene	µg/L and lbs/day	Grab or Composite	1/Quarter	Note c

Parameter	Units (Note a)	Sample Type	Minimum Sampling Frequency	Required Analytical Test Method
Remaining Priority Pollutants	µg/L	Grab or Composite (Note i)	1/Year	Notes c and j
TCDD Equivalents	µg/L and lbs/day	Grab or Composite	1/Quarter	Notes c and k
1,4-Dioxane	µg/L	Grab	1/Year	Note c

Footnotes for Table E-3

a. The mass emission (lbs/day) for the discharge shall be calculated and reported using the measured concentration and the actual flow rate measured at the time of discharge, using the formula.

$$M = 8.34 \times C_e \times Q$$

where: M = mass discharge for a pollutant, pounds/day
 Ce = measured concentration for a pollutant, mg/L
 Q = actual discharge flow rate, MGD

- b. Flow shall be recorded daily during each period of discharge. Periods of no flow shall also be reported.
- c. Pollutants shall be analyzed using the analytical methods described in 40 CFR part 136; for priority pollutants, the methods must meet the lowest MLs specified in Appendix 4 of the SIP. Where no methods are specified for a given pollutant, the methods must be approved by the Los Angeles Water Board or the State Water Board. If more than one analytical test method is listed for a given parameter, the Discharger must select a sufficiently sensitive method from the listed methods and corresponding ML necessary to demonstrate compliance with applicable effluent limitations.
- d. Chlorinated phenolic compounds are comprised of the following constituents from the CTR list of priority pollutants: 2-chlorophenol, 2,4-dichlorophenol, 3-methyl-4-chlorophenol, pentachlorophenol, and 2,4,6-trichlorophenol.
- e. Phenols are comprised of the following constituents from the CTR list of priority pollutants: phenol, 2,4-dimethylphenol, 2-methyl-4,6-dinitrophenol, 2,4-dinitrophenol, 2-nitrophenol, and 4-nitrophenol.
- f. Refer to section 5 below, Chronic Whole Effluent Toxicity Testing Requirements.
- g. Mercury shall be analyzed using EPA method 1631E, per 40 CFR part 136.
- h. If the results are non-detect for two years, the Discharger may submit a request for the monitoring frequency to be decreased to annually with Executive Officer approval.
- i. Grab samples **must** be collected for the analyses for each of the following parameters: pH, temperature, oil and grease, bacteria (enterococcus), bis(2-ethylhexyl)phthalate and volatile and semi-volatile organics.
- j. Priority Pollutants are those constituents referred to in 40 CFR section 401.15; a list of these pollutants is provided as Appendix A to 40 CFR part 423.
- k. TCDD equivalents shall be calculated using the following formula, where the Minimum Levels (ML), and toxicity equivalency factors (TEFs) are as listed in the Table below. The Discharger shall report all measured values of individual congeners, including data qualifiers. When calculating TCDD equivalents, the Discharger shall set congener concentrations below the minimum levels to zero. U.S. EPA method 1613 may be used to analyze dioxin and furan congeners.

$$\text{Dioxin-TEQ (TCDD equivalents)} = \sum(C_x \times \text{TEF}_x)$$

where: C_x = concentration of dioxin or furan congener x
 TEF_x = TEF for congener x

Toxicity Equivalency Factors

Congeners	Minimum Level (pg/L)	Toxicity Equivalence Factor (TEF)
2,3,7,8 - tetra CDD	10	1.0
1,2,3,7,8 - penta CDD	50	1.0
1,2,3,4,7,8 - hexa CDD	50	0.1
1,2,3,6,7,8 - hexa CDD	50	0.1
1,2,3,7,8,9 - hexa CDD	50	0.1
1,2,3,4,6,7,8 - hepta CDD	50	0.01
Octa CDD	100	0.0001
2,3,7,8 - tetra CDF	10	0.1
1,2,3,7,8 - penta CDF	50	0.05
2,3,4,7,8 - penta CDF	50	0.5
1,2,3,4,7,8 - hexa CDF	50	0.1
1,2,3,6,7,8 - hexa CDF	50	0.1
1,2,3,7,8,9 - hexa CDF	50	0.1
2,3,4,6,7,8 - hexa CDF	50	0.1
1,2,3,4,6,7,8 - hepta CDFs	50	0.01
1,2,3,4,7,8,9 - hepta CDFs	50	0.01
Octa CDF	100	0.0001

End of Footnotes for Table E-3

5. CHRONIC WHOLE EFFLUENT TOXICITY TESTING REQUIREMENTS

5.1. Discharge In-stream Waste Concentration (IWC) for Chronic Toxicity

The chronic toxicity IWC for this discharge is 100 percent effluent.

5.2. Sample Volume and Holding Time

The total sample volume shall be determined by the specific toxicity test method used. Sufficient sample volume shall be collected to perform the required toxicity test. Sufficient sample volume shall also be collected for subsequent TIE studies, if necessary, at each sampling event. All toxicity tests shall be conducted as soon as possible following sample collection. No more than 36 hours shall elapse before the conclusion of sample collection and test initiation.

5.3. Chronic Freshwater Species and Test Methods

If effluent samples are collected from outfalls discharging to receiving waters with salinity <1 ppt, the Discharger shall conduct the following chronic toxicity tests on effluent samples at the in-stream waste concentration for the discharge in accordance with species and test methods in *Short-term Methods for Estimating the Chronic Toxicity of Effluents and Receiving Waters to Freshwater Organisms* (EPA/821/R-02/013, 2002; Table IA, 40 CFR part 136). In no case shall these species be substituted with another test species unless written authorization from the Executive Officer is received.

5.3.1. A static renewal toxicity test with the fathead minnow, *Pimephales promelas* (Larval Survival and Growth Test Method 1000.0).

5.3.2 A static renewal toxicity test with the daphnid, *Ceriodaphnia dubia* (Survival and Reproduction Test Method 1002.01).

5.3.3. A static toxicity test with the green alga, *Selenastrum capricornutum* (also named *Raphidocelis subcapitata*) (Growth Test Method 1003.0).

5.4. Species Sensitivity Screening

Species sensitivity screening shall be conducted during this permit's first required sample collection. The Discharger shall collect a single effluent sample to initiate and concurrently conduct three toxicity tests using the fish, an invertebrate, and the alga species previously referenced. If the result of all three species is "Pass", then the species that exhibits the highest "Percent Effect" at the discharge IWC during species sensitivity screening shall be used for routine monitoring during the permit cycle. If only one species fails, then that species shall be used for routine monitoring during the permit cycle. If two or more species result in "Fail," then the species that exhibits the highest "Percent Effect" at the discharge IWC during the suite of species sensitivity screening shall be used for routine monitoring during the permit cycle, until a rescreening is required.

Species sensitivity screening is required every three years if there has been a discharge. The Discharger shall rescreen with the three species listed above and continue to monitor with the most sensitive species. If the first suite of rescreening tests demonstrates that the same species is the most sensitive, then the rescreening does not need to include more than one suite of tests. If a different species is the most sensitive or if there is ambiguity, then the Discharger may proceed with suites of screening tests for a minimum of three, but not to exceed five suites

During the calendar month, toxicity tests used to determine the most sensitive test species shall be reported as effluent compliance monitoring results for the chronic toxicity MDEL and MMEL.

5.5. Quality Assurance and Additional Requirements

5.5.1. Quality assurance measures, instructions, and other recommendations and requirements are found in the test methods manual previously referenced. Additional requirements are specified below.

- a. The discharge is subject to determination of "Pass" or "Fail" and "Percent Effect" from a chronic toxicity test using the Test of Significant Toxicity (TST) statistical t-test approach described in *National Pollutant Discharge Elimination System Test of Significant Toxicity Implementation Document* (EPA 833-R-10-003, 2010), Appendix A, Figure A-1, Table A-1 and Appendix B, Table B-1. The null hypothesis (H_0) for the TST approach is: Mean discharge IWC response $\leq 0.75 \times$ Mean control response. A test result that rejects this null hypothesis is reported as "Pass." A test result that does not reject this null hypothesis is reported as "Fail." The relative "Percent Effect" at the discharge IWC is defined and reported as: $((\text{Mean control response} - \text{Mean discharge IWC response}) \div \text{Mean control response}) \times 100$.
- b. If the effluent toxicity test does not meet all test acceptability criteria (TAC) specified in the referenced test method *Short-term Methods for Estimating the Chronic Toxicity of Effluents and Receiving Waters to Freshwater Organisms* (U.S.

EPA 2002, EPA-821-R-02-013) (See Table E.3, below) , then the Discharger must re-sample and re-test at the subsequent discharge event.

Table E-4. U.S. EPA Methods and Test Acceptability Criteria

Species & U.S. EPA Test Method Number	Test Acceptability Criteria
Fathead Minnow, <i>Pimephales promelas</i> , Larval Survival and Growth Test Method 1000.0. (Table 1 of Test Method)	80% or greater survival in controls; average dry weight per surviving organism in control chambers equals or exceeds 0.25 mg. (required)
Daphnid, <i>Ceriodaphnia dubia</i> , Survival and Reproduction Test Method 1002.0. Table 3 of Test Method)	80% or greater survival of all control organisms and an average of 15 or more young per surviving female in the control solutions. 60% of the surviving control females must produce three broods. (required)
Green Alga, <i>Selenastrum capricornutum</i> , Growth Toxicity Test Method 1003.0. (Table 3 of Test Method)	Mean cell density as least 1×10^6 cells/mL in the controls; and variability (CV%) among control replicates less than or equal to 20%. (required)

- c. Reference toxicant tests and effluent toxicity tests shall be conducted using the same test conditions (e.g., same test duration, etc.). Monthly reference toxicant testing is sufficient.
- d. All reference toxicant test results should be reviewed and reported according to EPA guidance on the evaluation of concentration-response relationships found in *Method Guidance and Recommendations for Whole Effluent Toxicity (WET) Testing* (40 CFR part 136) (EPA 821-B-00-004, 2000).
- e. The Discharger shall perform toxicity tests on final effluent samples. Chlorine and ammonia shall not be removed from the effluent sample prior to toxicity testing, unless explicitly authorized under this section of the Monitoring and Reporting Program and the rationale is explained in the Fact Sheet (Attachment F).

5.6. Accelerated Monitoring Schedule for Maximum Daily Single Result: “Fail and % Effect ≥ 50”.

The Maximum Daily single result shall be used to determine if accelerated testing needs to be conducted.

Once the Discharger becomes aware of this result, the Discharger shall implement an accelerated monitoring schedule within five calendar days of the receipt of the result. However, if the sample is contracted out to a commercial laboratory, the Discharger shall ensure that the first of five accelerated monitoring tests is initiated within seven calendar days of the Discharger becoming aware of the result. The accelerated monitoring schedule shall consist of a five concentration dilution series which includes the control with five dilutions, one of which must be the IWC, conducted at approximately two-week intervals, over an eight-week period; in preparation for the TRE process and associated reporting. If each of the accelerated toxicity tests results in

“Pass,” the Discharger shall return to routine monitoring for the next monitoring period. If one of the accelerated toxicity tests results in “Fail,” the Discharger shall immediately implement the TRE Process conditions set forth below. During accelerated monitoring schedules, only TST results (“Pass” or “Fail”) for chronic toxicity tests shall be reported as effluent compliance monitoring results for the chronic toxicity MDEL.

5.7. Preparation of an Initial Investigation TRE Work Plan

The Discharger shall prepare and submit a copy of the Discharger’s initial investigation TRE work plan to the Executive Officer of the Los Angeles Water Board for approval within 90 days of the effective date of this permit. If the Executive Officer does not disapprove the work plan within 60 days, the work plan shall become effective. The Discharger shall use U.S. EPA manual EPA/833B-99/002 (municipal) as guidance, or most current version, or EPA manual *Generalized Methodology for Conducting Industrial Toxicity Reduction Evaluations (EPA/600/2-88/070, April 1989)*. This work plan shall describe the steps that the Discharger intends to follow if toxicity is detected. At a minimum, the work plan shall include:

- 5.7.1. A description of the investigation and evaluation techniques that will be used to identify potential causes and sources of toxicity, effluent variability, and treatment system efficiency.
- 5.7.2. A description of the Facility’s methods of maximizing in-house treatment efficiency and good housekeeping practices, and a list of all chemicals used in the operation of the Facility.
- 5.7.3. If a TIE is necessary, an indication of the person who would conduct the TIEs (i.e., an in-house expert or an outside contractor).

5.8. Toxicity Identification Evaluation (TIE) and Toxicity Reduction Evaluation (TRE) Process

- 5.8.1. **TIE Implementation.** A toxicity test sample is immediately subject to TIE procedures to identify the toxic chemical(s), if a chronic toxicity test shows “Fail and % Effect value ≥ 50 ”. The Discharger shall initiate a TIE using as guidance, U.S. EPA manuals: *Methods for Aquatic Toxicity Identification Evaluations: Phase I Toxicity Characterization Procedures* (EPA/600/6-91/003, 1991); *Chronic TIE Manual: Toxicity Identification Evaluation: Characterization of Chronically Toxic Effluents, Phase I* (EPA/600/6-91/005F, 1992); *Methods for Aquatic Toxicity Identification Evaluations, Phase II Toxicity Identification Procedures for Samples Exhibiting Acute and Chronic Toxicity* (EPA/600/R-92/080, 1993); *Methods for Aquatic Toxicity Identification Evaluations, Phase III Toxicity Confirmation Procedures for Samples Exhibiting Acute and Chronic Toxicity* (EPA/600/R-92/081, 1993); and *Marine Toxicity Identification Evaluation (TIE): Phase I Guidance Document* (EPA/600/R-96-054, 1996). The TIE should be conducted on the species demonstrating the most sensitive toxicity response.
- 5.8.2. Many recommended TRE elements parallel required or recommended efforts for source control, pollution prevention, and storm water control programs. TRE efforts should be coordinated with such efforts. As toxic substances are identified or characterized, the Discharger shall continue the TRE by determining the

sources and evaluating alternative strategies for reducing or eliminating the substances from the discharge. All reasonable steps shall be taken to reduce toxicity to levels consistent with toxicity evaluation parameters.

- 5.8.3. The Discharger shall continue to conduct routine effluent monitoring for compliance determination purposes while the TIE and/or TRE process is taking place. Additional accelerated monitoring and TRE work plans are not required once a TRE has begun.
- 5.8.4. The Los Angeles Water Board recognizes that toxicity may be episodic and identification of causes and reduction of sources of toxicity may not be successful in all cases. The TRE may be ended at any stage if monitoring finds there is no longer toxicity.
- 5.8.5. The Board may consider the results of any TIE/TRE studies in an enforcement action.

5.9. Reporting

The Self-Monitoring Report (SMR) shall include a full laboratory report for each toxicity test. This report shall be prepared using the format and content of the test methods manual chapter, "Report Preparation," including:

- 5.9.1 The valid toxicity test results for the TST statistical approach, reported as "Pass" or "Fail" and "Percent Effect" at the chronic toxicity IWC for the discharge. All toxicity test results (whether identified as valid or otherwise) conducted during the calendar month shall be reported on the SMR due date specified in **Table E-6**.
- 5.9.2. A summary of water quality measurements for each toxicity test (e.g., pH, dissolved oxygen, temperature, conductivity, hardness, salinity, chlorine, ammonia).
- 5.9.3. The statistical analysis used in National Pollutant Discharge Elimination System Test of Significant Toxicity Implementation Document (EPA 833-R-10-003, 2010) Appendix A, Figure A-1, Table A-1, and Appendix B, Table B-1.
- 5.9.4. TRE/TIE results. The Los Angeles Water Board Executive Officer shall be notified no later than 30 days from completion of each aspect of TRE/TIE analyses. Prior to the completion of the final TIE/TRE report, the Discharger shall provide status updates in the monthly monitoring reports, indicating which TIE/TRE steps are underway and which steps have been completed.
- 5.9.5. Statistical program (e.g., TST calculator, CETIS, etc.) output results, including graphical plots, for each toxicity test.
- 5.9.6. Any additional QA/QC documentation or any additional chronic toxicity-related information, upon request from the Los Angeles Water Board.

6. LAND DISCHARGE MONITORING REQUIREMENTS - (NOT APPLICABLE)

7. RECYCLING MONITORING REQUIREMENTS - (NOT APPLICABLE)

8. RECEIVING WATER MONITORING REQUIREMENTS

8.1. Surface Water - Monitoring Location RSW-001

8.1.1. The Discharger shall monitor the South Fork of Arroyo Conejo at RSW-001 as follows:

Table E-5. Receiving Water Monitoring Requirements-RSW-001

Parameter	Units	Sample Type	Minimum Sampling Frequency	Required Analytical Test Method
Stream Flow	cfs	Recorder	1/Quarter (Note a)	---
Barium	µg/L	Grab	1/Year	Note c
Cis-1,2-Dichloroethylene	µg/L	Grab	1/Year	Note c
Priority Pollutants (Note b)	µg/L	Grab	1/Year	Note c
pH	standard units	Grab	1/Year	Notes c and d
Temperature	°F	Grab	1/Year	Notes c and d
Hardness (as CaCO ₃)	mg/L	Grab	1/Year	Notes c and d
<i>E. coli</i>	MPN/100mL or CFU/100mL	Grab	1 / Year	Note c
TCDD Equivalents	µg/L	Grab	1/Year (Note f)	Note e

Footnotes for Table E-5

- a. Concurrent with effluent sampling for copper and nickel. Also, see section 8.1.2. below.
- b. Priority Pollutants are those constituents referred to in 40 CFR part 131 or the California Toxics Rule (CTR).
- c. Pollutants shall be analyzed using the analytical methods described in 40 CFR section 136; for priority pollutants the methods must meet the lowest minimum levels (MLs) specified in Appendix 4 of the SIP. If no methods are specified for a given pollutant, it shall be analyzed by methods approved by this Regional Water Board or the State Water Board. If more than one analytical test method is listed for a given parameter, the Discharger must select from the listed methods and corresponding ML.
- d. Receiving water pH, hardness, and temperature must be analyzed at the same time the samples are collected for Priority Pollutants analysis. A hand-held field meter may be used for pH and temperature, provided the meter utilizes an EPA-approved algorithm/method and is calibrated and maintained in accordance with the manufacturer’s instructions. A calibration and maintenance log for each meter used for monitoring required by this Monitoring and Reporting Program shall be maintained at the Facility.
- e. TCDD equivalents shall be calculated using the following formula, where the Minimum Levels (ML), and toxicity equivalency factors (TEFs) are provided in the Table below. The Discharger shall report all measured values of individual congeners, including data qualifiers. When calculating TCDD equivalents the Discharger shall set congener concentrations below the minimum levels to zero. U.S. EPA method 1613 may be used to analyze dioxin and furan congeners.

$$\text{Dioxin-TEQ (TCDD equivalents)} = \sum(Cx \times \text{TEF}_x)$$

where: C_x = concentration of dioxin or furan congener x
 TEF_x = TEF for congener x

Minimum Levels, and Toxicity Equivalency Factors

Congeners	Minimum Level (pg/L)	Toxicity Equivalence Factor (TEF)
2,3,7,8 - tetra CDD	10	1.0
1,2,3,7,8 - penta CDD	50	1.0
1,2,3,4,7,8 - hexa CDD	50	0.1
1,2,3,6,7,8 - hexa CDD	50	0.1
1,2,3,7,8,9 - hexa CDD	50	0.1
1,2,3,4,6,7,8 - hepta CDD	50	0.01
Octa CDD	100	0.0001
2,3,7,8 - tetra CDF	10	0.1
1,2,3,7,8 - penta CDF	50	0.05
2,3,4,7,8 - penta CDF	50	0.5
1,2,3,4,7,8 - hexa CDF	50	0.1
1,2,3,6,7,8 - hexa CDF	50	0.1
1,2,3,7,8,9 - hexa CDF	50	0.1
2,3,4,6,7,8 - hexa CDF	50	0.1
1,2,3,4,6,7,8 - hepta CDFs	50	0.01
1,2,3,4,7,8,9 - hepta CDFs	50	0.01
Octa CDF	100	0.0001

- f. If the results of the analyses for 2 consecutive years indicate that TCDD equivalents are not detected, no further monitoring is required. If TCDD equivalents are detected, monitoring shall continue annually.

End of Footnotes for Table E-5

8.1.2. The Discharger may submit stream flow data collected by the Ventura County Watershed Protection District (VCWPD) and/or other entities acting on behalf of the agency from the gauging station in the South Fork of Arroyo Conejo located closest to RSW-001 in lieu of conducting the receiving water monitoring for the stream flow data. The analytical data shall include the type of instrument used in collecting the stream flow data, applicable analytical methods used in calculating the flow rate, including but not limited to date and time of monitoring, and name of person who performed the monitoring. If possible, the collection of stream flow data shall be concurrent with the effluent sampling for copper and nickel. If the stream flow data is not available during the reporting period, the Discharger shall submit the data as soon as it is obtained from VCWPD. The reason(s) why the stream flow data is not reported during the quarter shall be stated in the monitoring report. In addition, if there is no stream flow during the reporting period, the report shall so state.

The Discharger may coordinate with VCWPD to obtain permission to access the channel of the South Fork of Arroyo Conejo to collect the receiving water samples for priority pollutants, pH, temperature, and hardness at RSW-001.

8.2. Groundwater Monitoring - Not applicable.

9. REPORTING REQUIREMENTS

9.1. General Monitoring and Reporting Requirements

- 9.1.1. The Discharger shall comply with all Standard Provisions (Attachment D) related to monitoring, reporting, and recordkeeping.
- 9.1.2. If there is no discharge during any reporting period, the Discharger shall indicate under the statement of perjury that no effluent was discharged to surface water during the reporting period in the corresponding monitoring report.
- 9.1.3. If the Discharger monitors (other than for process/operational control, startup, research, or equipment testing) any influent, effluent, or receiving water constituent more frequently than required by this Order using approved analytical methods, the results of those analyses shall be included in the monitoring report. These results shall be reflected in the calculation of the average (or median) used in demonstrating compliance with this Order/Permit.
- 9.1.4. Each monitoring report shall contain a separate section titled "Summary of Non-Compliance" which discusses the compliance record and the corrective actions taken or planned that may be needed to bring the discharge into full compliance with waste discharge requirements. This section shall clearly list all non-compliance with discharge requirements, as well as all excursions of effluent limitations.
- 9.1.5. The Discharger shall inform the Los Angeles Water Board well in advance of any proposed construction activity that could potentially affect compliance with applicable requirements.
- 9.1.6. The Discharger shall report the results of chronic toxicity testing, TRE and TIE as required in the Attachment E, Monitoring and Reporting, section 5.

9.2. Self-Monitoring Reports (SMRs)

- 9.2.1. The Discharger shall electronically submit SMRs using the State Water Board's California Integrated Water Quality System (CIWQS) Program website: http://www.waterboards.ca.gov/water_issues/programs/ciwqs/ .
The CIWQS website will provide additional information for SMR submittal in the event there will be a planned service interruption for electronic submittal.
- 9.2.2. The Discharger shall report in the SMR the results for all monitoring specified in this MRP under sections 4 through 8. The Discharger shall submit quarterly SMRs including the results of all required monitoring using U.S. EPA-approved test methods or other test methods specified in this Order. SMRs are to include all new monitoring results obtained since the last SMR was submitted. If the Discharger monitors any pollutant more frequently than required by this Order, the results of this monitoring shall be included in the calculations and reporting of the data submitted in the SMR.

9.2.3. Monitoring periods and reporting for all required monitoring shall be completed according to the following schedule:

Table E-6. Monitoring Periods and Reporting Schedule

Sampling Frequency	Monitoring Period Begins On	Monitoring Period	SMR Due Date
Daily	Permit Effective Date	(Midnight through 11:59 PM or any 24-hour period) that reasonably represents a calendar day for purposes of sampling.	May 1 August 1 November 1 February 1
1/Month	Permit Effective Date	First day of calendar month through last day of calendar month	May 1 August 1 November 1 February 1
1/Quarter	Closest of January 1, April 1, July 1, or October 1 following (or on) permit effective date	January 1 through March 31 April 1 through June 30 July 1 through September 30 October 1 through December 31	May 1 August 1 November 1 February 1
2/Year	Closest of January 1 or July 1 following (or on) permit effective date	January 1 through June 30 July 1 through December 31	August 1 February 1 (Note a)
1/Year	January 1 following (or on) permit effective date	January 1 through December 31	February 1 (Note b)

Footnotes for Table E-6

- a. Submit with corresponding quarterly SMR.
- b. Submit with fourth quarter SMR

End of Footnotes for Table E-6

9.2.4. **Reporting Protocols.** The Discharger shall report with each sample result the applicable Reporting Level (RL) and the current Method Detection Limit (MDL), as determined by the procedure in 40 CFR part 136. The Discharger shall report the results of analytical determinations for the presence of chemical constituents in a sample using the following reporting protocols:

- a. Sample results greater than or equal to the RL shall be reported as measured by the laboratory (i.e., the measured chemical concentration in the sample).
- b. Sample results less than the RL, but greater than or equal to the laboratory’s MDL, shall be reported as “Detected, but Not Quantified,” or DNQ. The estimated chemical concentration of the sample shall also be reported. For the purposes of data collection, the laboratory shall write the estimated chemical concentration next to DNQ. The laboratory may, if such information is available, include numerical estimates of the data quality for

the reported result. Numerical estimates of data quality may be percent accuracy (\pm a percentage of the reported value), numerical ranges (low to high), or any other means considered appropriate by the laboratory.

- c. Sample results less than the laboratory's MDL shall be reported as "Not Detected," or ND.
- d. Dischargers are to instruct laboratories to establish calibration standards so that the ML value (or its equivalent if there is differential treatment of samples relative to calibration standards) is the lowest calibration standard. At no time is the Discharger to use analytical data derived from extrapolation beyond the lowest point of the calibration curve.

9.2.5. **Compliance Determination.** Compliance with effluent limitations for priority pollutants shall be determined using sample reporting protocols defined above and Attachment A. For purposes of reporting and administrative enforcement by the Los Angeles Water Board and State Water Board, the Discharger shall be deemed out of compliance with effluent limitations if the concentration of the priority pollutant in the monitoring sample is greater than the effluent limitation and greater than or equal to the reporting level (RL).

9.2.6. **Multiple Sample Data.** When determining compliance with an Average Monthly Effluent Limitation (AMEL), Average Weekly Effluent Limitation (AWEL), or Maximum Daily Effluent Limitation (MDEL) for priority pollutants and more than one sample result is available, the Discharger shall compute the arithmetic mean unless the data set contains one or more reported determinations of "Detected, but Not Quantified" (DNQ) or "Not Detected" (ND). In those cases, the Discharger shall compute the median in place of the arithmetic mean in accordance with the following procedure:

- a. The data set shall be ranked from low to high, ranking the reported ND determinations lowest, DNQ determinations next, followed by quantified values (if any). The order of the individual ND or DNQ determinations is unimportant.
- b. The median value of the data set shall be determined. If the data set has an odd number of data points, then the median is the middle value. If the data set has an even number of data points, then the median is the average of the two values around the middle unless one or both of the points are ND or DNQ, in which case the median value shall be the lower of the two data points where DNQ is lower than a value and ND is lower than DNQ.

9.2.7. **SMRs.** The Discharger shall submit SMRs in accordance with the following requirements:

- a. The Discharger shall arrange all reported data in a tabular format. The data shall be summarized to clearly illustrate whether the facility is operating in compliance with interim and/or final effluent limitations. The Discharger is not required to duplicate the submittal of data that is entered in a tabular format within CIWQS. When electronic submittal of data is required and CIWQS does not provide for entry into a tabular format within the system,

the Discharger shall electronically submit the data in a tabular format as an attachment.

- b. The Discharger shall attach a cover letter to the SMR. The information contained in the cover letter shall clearly identify violations of the waste discharge requirements; discuss corrective actions taken or planned; and the proposed time schedule for corrective actions. Identified violations must include a description of the requirement that was violated and a description of the violation.

9.3. Discharge Monitoring Reports (DMRs) - Not Applicable

9.4. Other Reports

- 9.4.1. Within 90 days of the effective date of this permit, the Discharger is required to submit the following to the Los Angeles Water Board:

- a. Initial Investigation TRE workplan
- b. SWPPP
- c. BMPP
- d. SCP

The SWPPP, BMPP and SCP status shall be reviewed at a minimum once per year and updated as needed to ensure all actual or potential sources of trash and pollutants in wastewater and stormwater discharges from the facility are addressed. All changes or revisions to the SWPPP, BMPP, and SCP shall be submitted to the Los Angeles Water Board within 30 days of any revisions.

- 9.4.2. **Climate Change Effects Vulnerability Assessment and Mitigation Plan**
Within 12 months from the effective date of this Order, the Discharger is required to submit a Climate Change Effects Vulnerability Assessment and Mitigation Plan (Climate Change Plan) to assess and manage climate change related-effects associated with the Facility operation, water supplies, collection system, water quality and beneficial uses.

ATTACHMENT F – FACT SHEET

TABLE OF CONTENTS

1. PERMIT INFORMATION	3
2. FACILITY DESCRIPTION	4
2.1. Description of Wastewater and Biosolids Treatment and Controls	4
2.2. Discharge Points and Receiving Waters.....	5
2.3. Summary of Existing Requirements and Self-Monitoring Report (SMR) Data	5
2.4. Compliance Summary	8
2.5. Planned Changes	8
3. APPLICABLE PLANS, POLICIES, AND REGULATIONS	8
3.1. Legal Authorities	9
3.2. California Environmental Quality Act (CEQA).....	9
3.3. State and Federal Laws, Regulations, Policies, and Plans.....	9
3.4. Impaired Water Bodies on the CWA section 303(d) List.....	13
3.5. Other Plans, Polices and Regulations	15
4. RATIONALE FOR EFFLUENT LIMITATIONS AND DISCHARGE SPECIFICATIONS	16
4.1. Discharge Prohibitions.....	17
4.2. Technology-Based Effluent Limitations (TBELs)	17
4.3. Water Quality-Based Effluent Limitations (WQBELs)	19
4.4. Final Effluent Limitation Considerations.....	35
4.5. Interim Effluent Limitations – Not Applicable	42
4.6. Land Discharge Specifications – Not Applicable	42
4.7. Recycling Specifications – Not Applicable.....	42
5. RATIONALE FOR RECEIVING WATER LIMITATIONS.....	42
5.1. Surface Water.....	42
5.2. Groundwater	42
6. RATIONALE FOR PROVISIONS	42
6.1. Standard Provisions	42
6.2. Special Provisions	43
7. RATIONALE FOR MONITORING AND REPORTING REQUIREMENTS.....	43
7.1. Influent Monitoring	43
7.2. Effluent Monitoring.....	44
7.3. Whole Effluent Toxicity Testing Requirements	44
7.4. Receiving Water Monitoring.....	44
7.5. Other Monitoring Requirements.....	45
8. PUBLIC PARTICIPATION	45
8.1. Notification of Interested Parties.....	45
8.2. Written Comments.....	45
8.3. Public Hearing	46
8.4. Reconsideration of Waste Discharge Requirements	46
8.5. Information and Copying.....	46
8.6. Register of Interested Persons	47
8.7. Additional Information.....	47

TABLE OF TABLES

Table F-1. Facility Information	3
Table F-2. Historic Effluent Limitations and Monitoring Data	5
Table F-3. Effluent Limitation Violations	8
Table F-4. Basin Plan Beneficial Uses.....	9
Table F-5. Summary of Technology-Based Effluent Limitations	18
Table F-6. Applicable Water Quality Criteria.....	22
Table F-7. Final WLAs for Total Recoverable Copper and Nickel	24
Table F-8. Final Concentration-Based WLA for Mercury	24
Table F-9. Concentration-Based WLAs for Organochlorine Pesticides and PCBs.	25
Table F-10. Final WLAs for Toxicity, Chlorpyrifos and Diazinon.....	25
Table F-11. Summary of Reasonable Potential Analysis.....	27
Table F-12. Summary of Final Effluent Limitations at Discharge Point 001	38
Table F-13. Final Effluent Limitations for Copper and Nickel at Discharge Point 001.....	41

ATTACHMENT F – FACT SHEET

As described in section 2.2 of this Order, the Los Angeles Water Board incorporates this Fact Sheet as findings of the Los Angeles Water Board supporting the issuance of this Order. This Fact Sheet includes the legal requirements and technical rationale that serve as the basis for the requirements of this Order.

This Order has been prepared under a standardized format to accommodate a broad range of discharge requirements for Dischargers in California. Only those sections or subsections of this Order that are specifically identified as “not applicable” have been determined not to apply to this Discharger. Sections or subsections of this Order not specifically identified as “not applicable” are fully applicable to this Discharger.

1. PERMIT INFORMATION

The following table summarizes administrative information related to the facility.

Table F-1. Facility Information

WDID	4A562397003
Discharger	TFX Aviation, Inc.
Name of Facility	TFX Aviation, Inc. Facility
Facility Address	3085 Old Conejo Road Newbury Park, CA 91320 Ventura County
Facility Contact, Title and Phone	Susan Salinas, Environmental Remediation, Projects Manager, Teleflex Incorporated, (805) 371-4815
Authorized Person to Sign and Submit Reports	Susan Salinas, Environmental Remediation, Projects Manager, Teleflex Incorporated, (805) 371-4815
Mailing Address	3085 Old Conejo Road, Newbury Park, CA 91320
Billing Address	Same as above
Type of Facility	Groundwater Treatment
Major or Minor Facility	Minor
Threat to Water Quality	2
Complexity	B
Pretreatment Program	Not Applicable
Recycling Requirements	Not Applicable
Facility Permitted Flow	0.110 million gallons per day (mgd)
Facility Design Flow	0.110 mgd
Watershed	Calleguas-Conejo Creek Watershed
Receiving Water	South Fork of Arroyo Conejo Creek
Receiving Water Type	Inland surface water

1.1. TFX Aviation, Inc. (hereinafter Discharger or Permittee), is the operator of TFX Aviation, Inc. Facility, a groundwater treatment facility located at Newbury Park (hereinafter Facility).

For the purposes of this Order, references to the “discharger” or “permittee” in applicable federal and state laws, regulations, plans, or policy are held to be equivalent to references to the Discharger herein.

1.2. The Facility discharges treated groundwater to a storm drain on Caltrans property, which then conveys the treated groundwater to the South Fork of Arroyo Conejo, a water of the United States. The discharge was previously regulated by Order No. R4-2015-0106 and National Pollutant Discharge Elimination System (NPDES) Permit No. CA0064599 adopted on May 14, 2015, and which expired on June 30, 2020. The terms and conditions of Order No. R4-2015-0106 have been automatically continued and remain in effect until the new waste discharge requirements (WDRs) and NPDES permit are adopted pursuant to this Order.

1.3. The Discharger filed a report of waste discharge (ROWD) and applied for reissuance of its WDRs and NPDES permit on December 13, 2019. The application was deemed complete on March 9, 2020. A site visit was conducted on January 10, 2020 to observe operations and collect additional data to develop permit limitations and conditions.

1.4. Federal regulations at 40 CFR section 122.46 limit the duration of NPDES permits to a fixed term not to exceed five years. However, pursuant to California Code of Regulations, title 23, section 2235.4, the terms and conditions of an expired permit are automatically continued pending reissuance of the permit if the Discharger complies with all federal NPDES requirements for continuation of expired permits.

2. FACILITY DESCRIPTION

2.1. Description of Wastewater and Biosolids Treatment and Controls

2.1.1. The Facility, shown in Attachment C-3, is owned and operated by TFX Aviation, Inc., and is located within the complex at 3085 Old Conejo Road in Newbury Park, California. The complex is 13.55 acres and has a deed restriction limiting use to commercial and industrial uses. The overall complex has been redeveloped for commercial use.

The site located at 3085 Old Conejo Road was formerly the location of the Talley Corporation (Talley), which operated an aircraft components manufacturing facility from the 1950s through 1989. Historical manufacturing processes at the Talley facility included machining of parts, degreasing, heat-treating, plating, and casting. The Talley facility previously disposed of its wastewater by evaporation in two onsite surface impoundments that reportedly leached wastewater to the underlying soil and groundwater. In 1989, a groundwater treatment system was installed at the site for groundwater cleanup. The site is undergoing groundwater remediation under the Resource Conservation and Recovery Act (RCRA) regulations.

The Facility is located within a fenced and bermed (8 inches high with lined concrete pad) treatment compound consisting of a groundwater treatment system, a small office building, a chemical storage area, a storage shed, and an

above-ground purge groundwater storage tank. The Facility’s stormwater is contained inside the bermed treatment compound, which drains into a central sump. The stormwater is treated together with the extracted groundwater through the treatment system and discharged under this NPDES Permit (Permit No. CA0064599).

2.1.2. The following are brief descriptions of the operations at the site:

The Discharger treats the site’s contaminated groundwater and discharges up to 0.110 million gallons per day (MGD). The operations at the site are limited to groundwater extraction, treatment, and discharge. There are nine extraction wells that are used to capture the contamination plume. The pumped groundwater is filtered and then treated with chemicals to facilitate the reduction of metals. The treated water is mixed in one tank and then retained in a second (retention) tank. The groundwater is then passed through bag filters and through an air stripper to remove volatile organic compounds (VOCs) prior to discharge. The groundwater treatment facility has an additional 1,100-gallon storage tank for the storage of excess untreated groundwater and rainwater.

The treatment system has six bag filters after the retention tank. Solids removed by the Facility’s bag filters are stored in drums and hauled off-site for proper disposal.

2.2. Discharge Points and Receiving Waters

The treated groundwater and stormwater from the bermed area are discharged through Discharge Point No. 001 located at the drop inlet to the newly constructed concrete lined drainage channel that runs adjacent to the southbound lanes of the 101 Freeway between the Wendy Road and Borchard Road Exits and into the South Fork of Arroyo Conejo, a water of the United States. The Discharge Point No. 001 is located at Latitude 34.18993° North, Longitude -118.941° West.

Attachment B depicts a topographic map of the area around the Facility. Attachment C depicts the schematic diagram of the wastewater flow

2.3. Summary of Existing Requirements and Self-Monitoring Report (SMR) Data

Effluent limitations and discharge specifications contained in Order No. R4-2015-0106 and monitoring data for discharges from Discharge Point 001 (Monitoring Location EFF-001) from July 2015 through September 2020 are as follows:

Table F-2. Historic Effluent Limitations and Monitoring Data

Parameter	Units	Average Monthly Limit	Maximum Daily Limit	Highest Reported Concentration	Notes
Biochemical Oxygen Demand (BOD) 5-day @ 20°C	mg/L	20	30	2.1	---
Total Suspended Solids (TSS)	mg/L	50	75	1.5	---
Oil and Grease	mg/L	10	15	<1.5	---
pH	s.u.	---	---	8.5	---

Parameter	Units	Average Monthly Limit	Maximum Daily Limit	Highest Reported Concentration	Notes
Settleable Solids	ml/L	0.1	0.3	0.1	---
Temperature	°F	---	---	98.6	Note a
Turbidity	NTU	50	75	4	---
Sulfides	mg/L	---	1	<0.050	---
Total Dissolved Solids	mg/L	---	850	890	---
Chloride	mg/L	---	150	140	---
Sulfate	mg/L	---	250	110	---
Boron	mg/L	---	1.0	0.14	---
Nitrate + Nitrite (as Nitrogen)	mg/L	---	10	11	---
Nitrite-N	mg/L	---	---	<0.025	Note b
Ammonia N	mg/L	---	---	0.15	Note b
Chronic Toxicity	Pass or Fail Effect (TST)	Pass	Pass or % Effect <50	Pass	---
Methyl Tertiary Butyl Ether (MTBE)	µg/L	---	---	<0.25	Note b
Tertiary Butyl Alcohol (TBA)	µg/L	---	---	<5	Note b
Methyl Ethyl Ketone (MEK)	µg/L	---	---	<2.5	Note b
Phenols	mg/L	---	1	<0.000098	---
Antimony, Total Recoverable (TR)	µg/L	---	---	<0.5	Note b
Arsenic, TR	µg/L	---	10	1.4	---
Beryllium, TR	µg/L	---	---	<0.25	Note b
Cadmium, TR	µg/L	5	10	<0.25	---
Chromium III	µg/L	---	---	1.3	Note b
Chromium VI, TR	µg/L	8.1	16.3	24	---
Copper, TR	µg/L	29	43	11	---
Lead, TR	µg/L	15.2	30.5	<0.5	---
Mercury, TR	µg/L	---	0.051	0.022	---
Nickel, TR	µg/L	160	1296	2.4	---
Selenium, TR	µg/L	4.1	7.2	2.4	---
Silver, TR	µg/L	22	44	<0.5	---
Thallium	µg/L	---	---	<0.5	Note b

Parameter	Units	Average Monthly Limit	Maximum Daily Limit	Highest Reported Concentration	Notes
Zinc, TR	µg/L	---	---	7.98	Note b
Cyanide	µg/L	---	---	<0.0025	Note b
TCDD Equivalents	µg/L	---	---	0.0000008	Notes b and c
Dioxane	µg/L	---	---	0.44	Note b
Benzene	µg/L	---	1	0.25	---
Carbon Tetrachloride	µg/L	---	0.5	<0.25	---
1,1-dichloroethane	µg/L	---	5	<0.25	---
1,2-dichloroethane	µg/L	---	0.5	<0.25	---
1,1-dichloroethylene	µg/L	---	6	<0.25	---
Dichlorobromomethane	µg/L	---	100	<0.25	---
Ethylbenzene	µg/L	---	10	<0.25	---
Tetrachloroethylene	µg/L	---	5	<0.25	---
Toluene	µg/L	---	10	<0.25	---
1,2-trans-dichloroethylene	µg/L	---	10	<0.25	---
1,1,1-trichloroethane	µg/L	---	5	<0.25	---
Trichloroethene	µg/L	---	5	9.7	---
Vinyl Chloride	µg/L	---	0.5	<0.25	---
Xylene	µg/L	---	10	<0.5	---
Bis(2-Ethylhexyl) Phthalate	µg/L	---	---	67	Notes b and c
Chlordane	µg/L	0.0006	0.001	<0.077	---
4,4'-DDT	µg/L	0.0006	0.0012	<0.0038	---
4,4'-DDE	µg/L	0.0006	0.001	<0.0029	---
4,4'-DDD	µg/L	0.0008	0.002	<0.0038	---
Dieldrin	µg/L	0.0001	0.0003	<0.0019	---
Polychlorinated Biphenyls (PCBs)	µg/L	0.0002	0.0003	<0.24	---
Phenolic Compounds (Chlorinated)	µg/L	---	1	0.98	---
Toxaphene	µg/L	0.0002	0.0003	<0.24	---
Chlorpyrifos	µg/L	0.014	---	<0.01	---
Diazinon	µg/L	0.10	0.10	<0.01	---

Footnotes for Table F-2

- a. The effluent limitation for temperature is 86°F as an Instantaneous Maximum.
- b. No effluent limitations were included in Order No. R4-2015-0106.
- c. The reported concentration for this pollutant exceeds the applicable water quality criteria and does not currently have a limit in Order No. R4-2015-0106.

End of Footnotes for Table F-2

2.4. Compliance Summary

Data submitted to the Los Angeles Water Board during the effective term of Order No. R4-2015-0106 (from July 2015 through September 2020) indicate that the Discharger has exceeded numeric effluent limitations for discharges from Discharge Point 001 (Monitoring Location EFF-001) as outlined in the table below:

Table F-3. Effluent Limitation Violations

Violation Date	Type of Limitation	Parameter	Unit	Effluent Limitation	Result
07/08/2015	Daily Maximum	Nitrate + Nitrite (as Nitrogen)	mg/L	10	11
02/03/2016	Instantaneous Maximum	Temperature	°F	86	98.6
01/31/2018	Monthly Average	Chromium VI	µg/L	8.1	10.45
01/03/2019	Daily Maximum	Trichloroethene	µg/L	5	9.7
07/07/2020	Daily Maximum	Total Dissolved Solids	mg/L	850	890

On June 17, 2020, Settlement Offer No. R4-2020-0066, to participate in the Expedited Payment Program in the amount of \$6,000.00 for violations of the requirements contained in Order No. R4-2015-0106 for nitrate + nitrite (as nitrogen), temperature, chromium VI, and trichloroethene was mailed to the Discharger. The Settlement Offer No. R4-2020-0066 included violations for nitrate + nitrite (as nitrogen), temperature, chromium VI, and trichloroethene that occurred during the period of 3rd Quarter 2015, 1st Quarter 2016, 1st Quarter 2018, and 1st Quarter 2019, respectively. The Discharger accepted the offer and the Los Angeles Water Board received the payment of \$6,000.00 from the Discharger on October 21, 2020.

The violation of the total dissolved solids limitation, which occurred on July 7, 2020, is being evaluated for appropriate enforcement action.

2.5. Planned Changes

The Discharger indicated at the time of permit development that there were no planned changes at the Facility.

3. APPLICABLE PLANS, POLICIES, AND REGULATIONS

The requirements contained in this Order are based on the requirements and authorities described in this section.

3.1. Legal Authorities

This Order serves as WDRs pursuant to article 4, chapter 4, division 7 of the California Water Code (commencing with section 13260). This Order is also issued pursuant to section 402 of the federal Clean Water Act (CWA) and implementing regulations adopted by the U.S. EPA and chapter 5.5, division 7 of the Water Code (commencing with section 13370). It shall serve as an NPDES permit authorizing the Discharger to discharge into waters of the United States at the discharge location described in section 2.2 above subject to the WDRs in this Order.

3.2. California Environmental Quality Act (CEQA)

Under Water Code section 13389, this action to adopt an NPDES permit is exempt from CEQA. See also *County of Los Angeles v. State Water Resources Control Board* (2006) 143 Cal.App.4th 985, 1007.

3.3. State and Federal Laws, Regulations, Policies, and Plans

3.3.1. Water Quality Control Plan. The Water Quality Control Plan for the Los Angeles Region (Basin Plan) designates beneficial uses, establishes water quality objectives (WQOs), and contains implementation programs and policies to achieve those objectives for all waters addressed through the plan. Requirements in this Order implement the Basin Plan. Beneficial uses applicable to the South Fork of Arroyo Conejo are as follows:

Table F-4. Basin Plan Beneficial Uses

Discharge Point	Receiving Water Name	Beneficial Use(s)
001	Calleguas Creek Reach 13 South Fork of Arroyo Conejo (above confluence with North Fork Arroyo Conejo)	<u>Existing:</u> Wildlife habitat (WILD). <u>Intermittent:</u> Groundwater recharge (GWR), freshwater replenishment (FRSH), warm freshwater habitat (WARM), Water Contact Recreation (REC-1), and Non-contact Water Recreation (REC-2). <u>Potential:</u> Municipal and domestic water supply (MUN)

While the South Fork of Arroyo Conejo is designated potential municipal and domestic supply (MUN) pursuant to State Water Resources Control Board Resolution 88-63 and Los Angeles Water Board Resolution No. 89-003 (as indicated by the “P*” in Chapter 2 of the Basin Plan), the Los Angeles Water Board only conditionally designated this waterbody as MUN in anticipation of further evaluation; therefore, effluent limitations are not included for protection of the MUN use at this time.

3.3.2. National Toxics Rule (NTR) and California Toxics Rule (CTR). U.S. EPA adopted the NTR on December 22, 1992, and later amended it on May 4, 1995 and November 9, 1999. About forty criteria in the NTR applied in California. On May 18, 2000, U.S. EPA adopted the CTR. The CTR promulgated new toxics

criteria for California and, in addition, incorporated the previously adopted NTR criteria that were applicable in the state. The CTR was amended on February 13, 2001. The CTR contains water quality criteria for priority pollutants applicable to all surface waters in California

- 3.3.3. State Implementation Policy.** On March 2, 2000, the State Water Board adopted the Policy for Implementation of Toxics Standards for Inland Surface Waters, Enclosed Bays, and Estuaries of California (State Implementation Policy or SIP). The SIP became effective on April 28, 2000, with respect to the priority pollutant criteria promulgated for California by the U.S. EPA through the NTR and to the priority pollutant objectives established by the Los Angeles Water Board in the Basin Plan. The SIP became effective on May 18, 2000, with respect to the priority pollutant criteria promulgated by the U.S. EPA through the CTR. The State Water Board adopted amendments to the SIP on February 24, 2005, that became effective on July 13, 2005. The SIP establishes implementation provisions for priority pollutant criteria and objectives and provisions for chronic toxicity control. Requirements of this Order implement the SIP.
- 3.3.4. Domestic Water Quality.** In compliance with Water Code section 106.3, it is the policy of the State of California that every human being has the right to safe, clean, affordable, and accessible water adequate for human consumption, cooking, and sanitary purposes. This Order promotes that policy by requiring discharges to meet maximum contaminant levels implemented by the Basin Plan that are designed to protect human health and ensure that water is safe for domestic use.
- 3.3.5. Alaska Rule.** On March 30, 2000, U.S. EPA revised its regulation that specifies when new and revised state and tribal water quality standards become effective for CWA purposes (40 CFR section 131.21, 65 Federal Register 24641 (April 27, 2000)). Under the revised regulation (also known as the Alaska Rule), new and revised standards submitted to U.S. EPA after May 30, 2000, must be approved by U.S. EPA before being used for CWA purposes. The final rule also provides that standards already in effect and submitted to U.S. EPA by May 30, 2000, may be used for CWA purposes, whether or not approved by U.S. EPA.
- 3.3.6. Antidegradation Policy.** CWA section 303 and federal regulation 40 CFR section 131.12 requires that the state water quality standards include an antidegradation policy consistent with the federal policy. The State Water Board established California's antidegradation policy in State Water Board Resolution 68-16 ("Statement of Policy with Respect to Maintaining High Quality of Waters in California"). Resolution 68-16 is deemed to incorporate the federal antidegradation policy where the federal policy applies under federal law. Resolution 68-16 requires that existing water quality be maintained unless degradation is justified based on specific findings. The Los Angeles Water Board's Basin Plan implements, and incorporates by reference, both the State and federal antidegradation policies. The permitted discharge must be consistent with the antidegradation provision of 40 CFR section 131.12 and State Water Board Resolution 68-16. Requirements of this Order implement federal and state antidegradation policies as described in section 4.4.2 of this Fact Sheet.

- 3.3.7. **Anti-Backsliding Requirements.** Sections 402(o) and 303(d)(4) of the CWA and federal regulations at 40 CFR section 122.44(l) restrict backsliding in NPDES permits. These anti-backsliding provisions require that effluent limitations in a reissued permit must be as stringent as those in the previous permit, with some exceptions in which limitations may be relaxed. Requirements of this Order implement federal anti-backsliding requirements as described in section 4.4.1 of this Fact Sheet.
- 3.3.8. **Endangered Species Act Requirements.** This Order does not authorize any act that results in the taking of a threatened or endangered species or any act that is now prohibited, or becomes prohibited in the future, under either the *California Endangered Species Act (Fish and Game Code, §§ 2050 to 2097)* or the *Federal Endangered Species Act (16 U.S.C.A. §§ 1531 to 1544)*. This Order requires compliance with effluent limits, receiving water limits, and other requirements to protect the beneficial uses of waters of the state. The Discharger is responsible for meeting all requirements of the applicable federal and state *Endangered Species Act*.
- 3.3.9. **Monitoring and Reporting.** 40 CFR section 122.48 requires that all NPDES permits specify requirements for recording and reporting monitoring results. Water Code section 13383 authorizes the Los Angeles Water Board to require technical and monitoring reports. The Monitoring and Reporting Program (MRP) establishes monitoring and reporting requirements to implement federal and state requirements. This MRP is provided in Attachment E.
- 3.3.10. **Mercury Provisions.** The State Water Board adopted “*Part 2 of the Water Quality Control Plan for Inland Surface Waters, Enclosed Bays, and Estuaries of California (ISWEBE); Tribal and Subsistence Fishing Beneficial Uses and Mercury Provisions*” (Mercury Provisions) through Resolution No. 2017-0027, which was approved by the Office of Administrative Law (OAL) on June 28, 2017 and became effective upon U.S. EPA approval on July 14, 2017. The Mercury Provisions established one narrative and four numeric water quality objectives for mercury and three new beneficial use definitions, implemented through NPDES permits issued pursuant to CWA section 402, waste discharge requirements, or waivers of waste discharge requirements. The Mercury Provisions included specific implementation provisions for individual non-storm water NPDES permits for municipal and industrial dischargers; storm water discharges regulated by Municipal Separate Storm Sewer System (MS4) permits and the Industrial General Permit; as well as for storm water from mine site remediation sites; dredging activities; wetland projects and nonpoint source discharges. In general, these implementation provisions do not apply to dischargers that discharge to receiving waters for which an existing mercury or methylmercury total maximum daily load (TMDL) is established pertaining to the same beneficial use or uses with some exceptions. This TMDL assigns concentration-based waste load allocations for mercury for all Calleguas Creek reaches. The May 2, 2017, Final Staff Report for Mercury Provisions, pages 39, states that “... the implementation requirements in the Provisions would not supersede the Calleguas Creek TMDL program of implementation. This is because the Calleguas Creek TMDL has prey fish targets that are equivalent to the Prey Fish Water Quality Objective and the

California Least Tern Prey Fish Water Quality Objective in the Provisions. So the TMDL program of implementation should be consistent with meeting the objectives that protect wildlife and recreational fishing in the Provisions. On the other hand, the Provisions do not include a relative load analysis such as that done as part of a TMDL.” Therefore, the Mercury Provisions do not apply to the TFX Aviation Facility.

- 3.3.11. **Trash Amendments.** The State Water Board adopted the “*Amendment to the Ocean Plan and Part I Trash Provisions of the Water Quality Control Plan for Inland Surface Waters, Enclosed Bays, and Estuaries of California*” (Trash Amendments) through Resolution Number 2015-0019, which was approved by OAL on December 2, 2015 and became effective upon U.S. EPA approval on January 12, 2016. The Trash Amendments established a narrative water quality objective and a prohibition on the discharge of trash, to be implemented through permits issued pursuant to CWA section 402(p), waste discharge requirements, or waivers of waste discharge requirements.

The Trash Amendments apply to all surface waters of the State, with the exception of those waters within the jurisdiction of the Los Angeles Water Board where trash or debris TMDLs were in effect prior to the effective date of the Trash Amendments. This Order regulates a discharge pursuant to CWA section 402(p) and there are currently no Trash TMDLs for Calleguas Creek Reach 13 (South Fork of Arroyo Conejo Creek). Therefore, the discharges described in this Order are subject to the Trash Amendments. This Order incorporates the requirements of the Trash Amendments through the prohibition of trash discharges to the discharge point. This Order also requires the Discharger to update and implement a Storm Water Pollution Prevention Plan (SWPPP), which shall include specific BMPs used as storm water control measures that the Discharger will undertake to prevent the discharge of trash from the Facility to Calleguas Creek Reach 13 (South Fork of Arroyo Conejo Creek). The Discharger is required to detail and submit to the Los Angeles Water Board the SWPPP.

- 3.3.12. **Water Quality Control Plan for Inland Surface Waters, Enclosed Bays, and Estuaries in California – Part 3 Bacteria Provisions (Bacteria Provisions).** On August 7, 2018, the State Water Resources Control Board adopted Resolution Number 2018-0038, “*Part 3 of the Water Quality Control Plan for Inland Surface Waters, Enclosed Bays, and Estuaries of California—Bacteria Provisions and a Water Quality Standards Variance Policy and an Amendment to the Water Quality Control Plan for Ocean Waters of California*” (Bacteria Provisions). The Bacteria Provisions: (1) establish a beneficial use definition of limited water contact recreation (LREC-1); (2) establish new statewide numeric water quality objectives for bacteria to protect primary contact recreation (REC-1) beneficial use; (3) include implementation elements; and (4) create a water quality standards variance framework under provisions established by the U.S. EPA. OAL approved the regulatory action on February 4, 2019. On March 22, 2019 U.S. EPA approved the Bacteria Provisions and they became effective. This Order implements the applicable numeric water quality objectives for bacteria included in the Bacteria Provisions.

3.4. Impaired Water Bodies on the CWA section 303(d) List

Section 303(d) of the CWA requires states to identify specific water bodies where water quality standards are not expected to be met after implementation of technology-based effluent limitations on point sources. For all 303(d)-listed water bodies and pollutants, the Los Angeles Water Board plans to develop and adopt total maximum daily loads (TMDLs) that will specify waste load allocations (WLAs) for point sources and load allocations for non-point sources.

The U.S. EPA approved the California 2014-2016 CWA section 303(d) List of Impaired Waters (2014-16 303(d) List) on April 6, 2018. Certain receiving waters in the Los Angeles and Ventura County watersheds do not fully support beneficial uses and therefore have been classified as impaired on the 2014-16 303(d) List and have been scheduled for TMDL development. The Facility discharges into the South Fork of Arroyo Conejo. The 2014-2016 303(d) List of impaired water bodies includes Calleguas Creek Reach 13 (Arroyo Conejo South Fork). The pollutants of concern include ammonia, chlordane (tissue) [refers to the sum of aldrin, dieldrin, chlordane, endrin, heptachlor, heptachlor epoxide, hexachlorocyclohexane (HCH) (including lindane), endosulfan, and toxaphene], chlordane, chloride, DDT (tissue), dieldrin, endosulfan (tissue), PCBs (polychlorinated biphenyls), sulfates, total dissolved solids, toxaphene (tissue and sediment), and toxicity.

The following are summaries of the TMDLs for Calleguas Creek, its Tributaries, and Mugu Lagoon:

- 3.4.1. **Calleguas Creek Watershed Salts TMDL.** On October 4, 2007, the Los Angeles Water Board adopted Resolution No. R4-2007-016, *Amendment to the Water Quality Control Plan – Los Angeles Region to Incorporate the Total Maximum Daily Load for Boron, Chloride, Sulfate, and TDS (Salts) in the Calleguas Creek Watershed* (Salts TMDL). The Salts TMDL was approved by the State Water Board, OAL, and U.S. EPA on May 20, 2008, November 6, 2008, and December 2, 2008, respectively. This TMDL became effective on December 2, 2008. The discharge effluent limitations for boron, chloride, sulfate, and TDS are based on this TMDL.
- 3.4.2. **Calleguas Creek Watershed Nitrogen Compounds and Related Effects TMDL.** On October 24, 2002, the Los Angeles Water Board adopted Resolution No. 02-017, *Amendment to the Water Quality Control Plan – Los Angeles Region to include a TMDL for Nitrogen Compounds and Related Effects in Calleguas Creek* (Nitrogen TMDL). The TMDL was approved by the State Water Board and OAL on March 19, 2003, and June 5, 2003, respectively. The TMDL became effective on July 16, 2003, after being approved by U.S. EPA on June 20, 2003. The TMDL establishes WLAs for nitrogen compounds (ammonia, nitrite, and nitrate) for discharges from Publicly Owned Treatment Works (POTWs) and runoff from agricultural activities in the Calleguas Creek Watershed. The TMDL did not establish WLAs for any other discharges in the Calleguas Creek Watershed. Thus, the WLAs for nitrogen compounds are not implemented in this Order.

3.4.3. Calleguas Creek Watershed Toxicity, Chlorpyrifos, and Diazinon TMDL.

On July 7, 2005, the Los Angeles Water Board adopted Resolution No. R4-2005-009, *Amendment to the Water Quality Control Plan for the Los Angeles Region to Incorporate a Total Maximum Daily Load for Toxicity, Chlorpyrifos, and Diazinon in Calleguas Creek, its Tributaries, and Mugu Lagoon* (Toxicity TMDL). The TMDL was approved by the State Water Board, OAL, and U.S. EPA on September 22, 2005, December 22, 2005, and March 14, 2006, respectively. The TMDL became effective on March 24, 2006. This Order includes effluent limitations for chlorpyrifos and diazinon based on WLAs established by the Toxicity TMDL.

The Toxicity TMDL includes a WLA of 1.0 TUc for toxicity, which is required to be implemented in accordance with U.S. EPA, State Water Board, and Regional Water Board resolutions, guidance and policy at the time of permit issuance or renewal. Consistent with the Toxicity TMDL Implementation Plan, the toxicity WLA is implemented using the recent U.S. EPA guidance, *National Pollutant Discharge Elimination System Test of Significant Toxicity Implementation Document* (U.S. EPA 833-R-10-003, June 2010).

3.4.4. Calleguas Creek Organochlorine (OC) Pesticides, Polychlorinated Biphenyls (PCBs), and Siltation TMDL.

On July 7, 2005, the Los Angeles Water Board adopted Resolution No. R4-2005-010, *Amendment to the Water Quality Control Plan for the Los Angeles Region to Incorporate a Total Maximum Daily Load for Organochlorine Pesticides, Polychlorinated Biphenyls, and Siltation in Calleguas Creek, its Tributaries, and Mugu Lagoon* (OC Pesticides and PCBs TMDL). The TMDL was approved by the State Water Board, OAL, and U.S. EPA on September 22, 2005, January 20, 2006, and March 14, 2006, respectively. The TMDL became effective on March 24, 2006. The OC Pesticides and PCBs TMDL establishes WLAs (daily maximum and monthly average) for the water column for minor point sources, including the Facility, for chlordane, 4,4'-DDD, 4,4'-DDE, 4,4'-DDT, dieldrin, PCBs, and toxaphene. The final WLAs for these constituents were incorporated into this Order.

3.4.5. Calleguas Creek Watershed Metals and Selenium TMDL.

On June 8, 2006, the Los Angeles Water Board adopted Resolution No. R4-2006-012, *Amendment to the Water Quality Control Plan for the Los Angeles Region to Incorporate a Total Maximum Daily Load for Metals for the Calleguas Creek, its Tributaries, and Mugu Lagoon* (Metals and Selenium TMDL). The Metals and Selenium TMDL was approved by the State Water Board, OAL, and U.S. EPA on October 25, 2006, February 2, 2007, and March 26, 2007, respectively. The Metals TMDL became effective on March 26, 2007. The Los Angeles Water Board adopted Resolution R16-007 to revise the Metals and Selenium TMDL on October 13, 2016. The revisions were approved by the State Water Board, Office of Administrative Law, and U.S. EPA on February 22, 2017, May 18, 2017, and June 9, 2017, respectively. The revisions became effective on June 23, 2017. The Metals and Selenium TMDL includes final WLAs for "Other NPDES Dischargers," including the Facility, for total recoverable copper and total recoverable nickel for both wet and dry weather for Calleguas Creek

Reach 13. There are no selenium waste load allocations developed for this Reach. The TMDL assigns final WLAs for “Other NPDES Dischargers” for mercury in all reaches. The final WLAs for total recoverable copper, total recoverable nickel, and mercury are incorporated into this Order.

3.5. Other Plans, Policies and Regulations

3.5.1. Climate Change Adaptation and Mitigation. On March 7, 2017 the State Water Board adopted a resolution in recognition of the challenges posed by climate change that require a proactive approach in all State Water Board actions, including drinking water regulation, water quality protection, and financial assistance (Resolution No. 2017-0012). The resolution lays the foundation for a response to climate change that is integrated into all State Water Board actions by giving direction to the State Water Board divisions and encouraging coordination with the regional boards. The Los Angeles Water Board adopted a similar resolution, “A Resolution to Prioritize Actions to Adapt and Mitigate the Impacts of Climate Change on the Los Angeles Region’s Water Resources and Associated Beneficial Uses” (Resolution No. R18-004), on May 10, 2018. The resolution summarizes the steps taken so far to address the impacts of climate change within the Los Angeles Water Board’s programs and lists a series of steps to move forward. These include the identification of potential regulatory adaptation and mitigation measures that could be mitigated on a short-term and long-term basis by each of the Los Angeles Water Board’s programs to take into account, and assist in mitigating where possible, the effects of climate change on water resources and associated beneficial uses. This Order contains provisions to require planning and actions to address climate change impacts in accordance with both the State and Los Angeles Water Boards’ resolutions.

The Permittee shall develop a Climate Change Effects Vulnerability Assessment and Management Plan (Climate Change Plan) and submit the Climate Change Plan to the Los Angeles Water Board for the Executive Officer’s approval no later than 12 months after the effective date of this Order. The Climate Change Plan shall include an assessment of short- and long-term vulnerabilities of facilities and operations as well as plans to address vulnerabilities of collection systems, facilities, treatment systems, and outfalls for predicted impacts in order to ensure that facility operations are not disrupted, compliance with permit conditions is achieved, and receiving waters are not adversely impacted by discharges. Control measures shall include, but are not limited to, emergency procedures, contingency plans, alarm/notification systems, training, backup power and equipment, and the need for planned mitigations to ameliorate climate-induced impacts including, but not limited to, changing influent and receiving water quality and conditions, as well as the impact of rising sea level (where applicable), wildfires, storm surges, and back-to-back severe storms that are expected to become more frequent.

3.5.2. Sources of Drinking Water Policy. On May 19, 1988, the State Water Board adopted Resolution No. 88-63, Sources of Drinking Water Policy, which established a policy that all surface and ground waters, with limited exemptions, are suitable or potentially suitable for municipal and domestic supply. To be

consistent with State Water Board Resolution 88-63, on March 27, 1989, the Los Angeles Water Board adopted Resolution No. 89-03, Incorporation of Sources of Drinking Water Policy into the Water Quality Control Plans (Basin Plans) – Santa Clara River Basin (4A)/ Los Angeles River Basin (4B). This permit is designed to be consistent with the existing Basin Plan.

3.5.3. Title 22 of the California Code of Regulations (CCR Title 22). The State Water Resources Control Board, Division of Drinking Water, established primary and secondary maximum contaminant levels (MCLs) for inorganic, organic, and radioactive contaminants in drinking water. These MCLs are codified in Title 22. The Basin Plan (Chapter 3) incorporates Title 22 primary MCLs by reference. This incorporation by reference is prospective, including future changes to the incorporated provisions as the changes take effect. Title 22 primary MCLs have been used as bases for effluent limitations in WDRs and NPDES permits to protect the groundwater recharge (GWR) beneficial use when the receiving groundwater is designated as MUN. Also, the Basin Plan specifies that “Ground waters shall not contain taste or odor-producing substances in concentrations that cause nuisance or adversely affect beneficial uses.” This Order contains effluent limitations based on Title 22 MCLs to protect the GWR beneficial use.

4. RATIONALE FOR EFFLUENT LIMITATIONS AND DISCHARGE SPECIFICATIONS

The CWA requires point source dischargers to control the amount of conventional, non-conventional, and toxic pollutants that are discharged into the waters of the United States. The control of pollutants discharged is established through effluent limitations and other requirements in NPDES permits. There are two principal bases for effluent limitations in the Code of Federal Regulations: 40 CFR section 122.44(a) requires that permits include applicable technology-based limitations and standards; and 40 CFR section 122.44(d) requires that permits include water quality-based effluent limitations to attain and maintain applicable numeric and narrative water quality criteria to protect the beneficial uses of the receiving water.

The Discharger operates a groundwater extraction and treatment system to clean up groundwater contamination as a result of former manufacturing operations. The discharge is comprised of treated groundwater commingled with occasional stormwater. The list of pollutants of concern for the discharges covered under this Order were identified based on effluent monitoring data, constituents regulated in the previous Order No. R4-2015-0106, and the pollutants of concern on the 2014-16 303(d) List for Calleguas Creek Reach 13 (Arroyo Conejo South Fork). Order No. R4-2015-0106 included effluent limitations for turbidity, settleable solids, total suspended solids (TSS), oil and grease, biochemical oxygen demand (BOD), pH, temperature, and sulfides because they are parameters typically used to characterize discharges of treated groundwater. Sulfate, chloride, TDS, boron, and nitrogen (as nitrate + nitrite) are commonly present in groundwater, therefore, these constituents are still considered pollutants of concern. Further, the Basin Plan contains water quality objectives for certain parameters (e.g., temperature, pH, minerals); as such, they are considered pollutants of concern. Calleguas Creek Reach 13 (Arroyo Conejo South Fork) is listed as impaired for ammonia, chemA (tissue) [refers to the sum of aldrin, dieldrin, chlordane, endrin, heptachlor, heptachlor epoxide, hexachlorocyclohexane (HCH) (including lindane), endosulfan, and toxaphene], chlordane, chloride, DDT (tissue), dieldrin, endosulfan (tissue), PCBs

(polychlorinated biphenyls), sulfates, total dissolved solids, toxaphene (tissue and sediment), and toxicity. Therefore, these constituents also are pollutants of concern.

Generally, mass-based effluent limitations ensure that proper treatment, and not dilution, is employed to comply with the final effluent concentration limitations. Section 122.45(f)(1) requires that all permit limitations, standards or prohibitions be expressed in terms of mass units except under the following conditions: (1) for pH, temperature, radiation or other pollutants that cannot appropriately be expressed by mass limitations; (2) when applicable standards or limitations are expressed in terms of other units of measure; or (3) if in establishing technology-based permit limitations on a case-by-case basis, limitations based on mass are infeasible because the mass or pollutant cannot be related to a measure of production. The limitations, however, must ensure that dilution will not be used as a substitute for treatment. This Order includes mass-based effluent limitations, where appropriate, to comply with Section 122.45(f)(1).

The variety of potential pollutants found in the Facility discharges presents a potential for aggregate toxic effects to occur. Whole effluent toxicity (WET) is an indicator of the combined effect of pollutants contained in the discharge. Chronic toxicity is a more stringent requirement than acute toxicity. Therefore, chronic toxicity is considered a pollutant of concern for protection and evaluation of narrative Basin Plan Objectives.

4.1. Discharge Prohibitions.

Discharge Prohibitions in this Order are based on the federal CWA, the Code of Federal Regulations (CFR), the Basin Plan, the Water Code, State Water Board's plans and policies, U.S. EPA guidance and regulations, and the previous permit provisions. This Order includes a prohibition for trash in order to implement the statewide Trash Amendments. The discharge prohibitions included in this Order are consistent with the requirements set for other dischargers within the Los Angeles Region that are regulated by NPDES permits.

4.2. Technology-Based Effluent Limitations (TBELs)

4.2.1. **Scope and Authority.** Section 301(b) of the CWA and implementing U.S. EPA permit regulations at 40 CFR section 122.44 require that permits include conditions meeting applicable technology-based requirements at a minimum, and any more stringent effluent limitations necessary to meet applicable water quality standards. The discharges authorized by this Order must meet minimum federal technology-based requirements based on Best Professional Judgment (BPJ) in accordance with 40 CFR section 125.3

The CWA requires that technology-based effluent limitations be established based on several levels of controls:

- a. Best practicable treatment control technology (BPT) represents the average of the best existing performance by well-operated facilities within an industrial category or subcategory. BPT standards apply to toxic, conventional, and non-conventional pollutants.
- b. Best available technology economically achievable (BAT) represents the best existing performance of treatment technologies that are economically

achievable within an industrial point source category. BAT standards apply to toxic and non-conventional pollutants.

- c. Best conventional pollutant control technology (BCT) represents the control from existing industrial point sources of conventional pollutants including BOD, TSS, fecal coliform, pH, and oil and grease. The BCT standard is established after considering a two-part reasonableness test. The first test compares the relationship between the costs of attaining a reduction in effluent discharge and the resulting benefits. The second test examines the cost and level of reduction of pollutants from the discharge from publicly owned treatment works to the cost and level of reduction of such pollutants from a class or category of industrial sources. Effluent limitations must be reasonable under both tests.
- d. New source performance standards (NSPS) represent the best available demonstrated control technology standards. The intent of NSPS guidelines is to set limitations that represent state-of-the-art treatment technology for new sources.

The CWA requires U.S. EPA to develop effluent limitations, guidelines and standards (ELGs) representing application of BPT, BAT, BCT, and NSPS. Section 402(a)(1) of the CWA and 40 CFR section 125.3 authorize the use of BPJ to derive technology-based effluent limitations on a case-by-case basis where ELGs are not available for certain industrial categories and/or pollutants of concern. Where BPJ is used, the Los Angeles Water Board must consider specific factors outlined in 40 CFR section 125.3

4.2.2. Applicable TBELs

The discharge from this Facility is primarily treated groundwater. As such, there are currently no technology-based ELGs that apply to the Facility. The technology-based requirements in this Order are based on case-by-case numeric limitations, developed in Order No. R4-2015-0106, using BPJ. In setting these limitations, the Los Angeles Water Board considered the factors listed in 40 CFR section 125.3(d) and chose to apply BCT for these conventional pollutants. The technology-based effluent limitations are the same limitations included in the Order No. R4-2015-0106 for BOD, oil and grease, and TSS. Pursuant to state and federal anti-backsliding regulations, this Order retains effluent limitations for these pollutants as technology-based effluent limitations. These limitations are consistent with technology-based limitations included in other Orders within the State for similar types of discharges.

The Order limitations reflecting BPJ will serve as the equivalent of technology-based effluent limitations, in the absence of established ELGs, in order to carry out the purposes and intent of the CWA. The following table summarizes the technology-based effluent limitations for Discharge Point 001.

Table F-5. Summary of Technology-Based Effluent Limitations

Parameter	Units	Average Monthly	Maximum Daily
BOD ₅ 20°C	mg/L	20	30

Parameter	Units	Average Monthly	Maximum Daily
TSS	mg/L	50	75
Oil and Grease	mg/L	10	15

4.3. Water Quality-Based Effluent Limitations (WQBELs)

4.3.1. Scope and Authority

CWA Section 301(b) and 40 CFR section 122.44(d) require that permits include limitations more stringent than applicable federal technology-based requirements where necessary to achieve applicable water quality standards.

40 CFR Section 122.44(d)(1)(i) requires that permits include effluent limitations for all pollutants that are or may be discharged at levels that have the reasonable potential to cause or contribute to an exceedance of a water quality standard in the receiving water, including numeric and narrative objectives. Where reasonable potential has been established for a pollutant, but there is no numeric criterion or objective for the pollutant, water quality-based effluent limitations (WQBELs) must be established using: (1) U.S. EPA criteria guidance under CWA section 304(a), supplemented where necessary by other relevant information; (2) an indicator parameter for the pollutant of concern; or (3) a calculated numeric water quality criterion, such as a proposed state criterion or policy interpreting the state’s narrative criterion, supplemented with other relevant information, as provided in section 122.44(d)(1)(vi). WQBELs must also be consistent with the assumptions and requirements of TMDL WLAs approved by U.S. EPA.

The process for determining reasonable potential and calculating WQBELs when necessary is intended to protect the designated uses of the receiving water as specified in the Basin Plan, and achieve applicable water quality objectives and criteria that are contained in other state plans and policies, or any applicable water quality criteria contained in the CTR and NTR. The specific procedures for determining reasonable potential and, if necessary, calculating WQBELs are contained in the SIP.

4.3.2. Applicable Beneficial Uses and Water Quality Criteria and Objectives

The Basin Plan establishes the beneficial uses for surface water bodies in the Los Angeles Region. The beneficial uses of Calleguas Creek Reach 13 (South Fork of Arroyo Conejo Creek) affected by the discharge have been described previously in this Fact Sheet. The Basin Plan also specifies narrative and numeric WQOs applicable to surface water as described below:

- a. **pH.** The effluent limitation for pH in this permit requiring that the wastes discharged shall at all times be within the range of 6.5 to 8.5 is taken from the Basin Plan (page 3-15) which reads “the pH of inland surface waters shall not be depressed below 6.5 or raised above 8.5 as a result of waste discharge.”
- b. **Biochemical Oxygen Demand (BOD₅).** The 5-day BOD test indirectly measures the amount of readily degradable organic material in water by measuring the residual dissolved oxygen after a period of incubation (usually 5

- days at 20° C). This Order addresses BOD through technology-based effluent limitations.
- c. **Oil and Grease** The limits for oil and grease are based on the Basin Plan (page 3-11) narrative, “Waters shall not contain oils, greases, waxes, or other materials in concentrations that result in a visible film or coating on the surface of the water or on objects in the water, that cause nuisance, or that otherwise adversely affect beneficial uses .This Order addresses oil and grease through technology-based effluent limitations.
- d. **Solid, Suspended or Settleable Materials.** The Basin Plan requires that, “*Waters shall not contain suspended or settleable material in concentrations that cause nuisance or adversely affect beneficial uses.*” This narrative objective has been translated into a numeric effluent limitation, based on U.S. EPA’s *Quality Criteria for Water* (commonly known as the “Gold Book”). In the Gold Book, U.S. EPA notes that “*In a study downstream from a discharge where inert suspended solids were increased to 80 mg/L, the density of macroinvertebrates decreased by 60 percent...*”. This indicates that suspended solids concentrations of 80 mg/L in the receiving water resulted in adverse effects to aquatic life. Therefore, this Order establishes a maximum daily effluent limitation of 75 mg/L for Total Suspended Solids (TSS). This limitation is expected to be protective of receiving water quality, consistent with what is typically established for similar discharges in the Los Angeles Region, and achievable with technologies employed at the Facility.
- e. **Turbidity.** The Basin Plan requirements for turbidity are as follows
- i. Where natural turbidity is between 0 and 50 NTU, increases shall not exceed 20%.
 - ii. Where natural turbidity is greater than 50 NTU, increases shall not exceed 10%.
 - iii. This Order applies the water quality objective for turbidity as a receiving water limitation in addition to the technology-based effluent limitation for TSS.
- f. **Temperature.** Order No. R4-2015-0106 included an effluent limitation of 86 °F. This Order updates the temperature effluent limitation to 80 °F to align it with the water quality objective in the Basin Plan for temperature that is applicable to inland surface waters with WARM beneficial use designation such as the South Fork of Arroyo Conejo. The applicable WQO states:
“For waters designated WARM, water temperature shall not be altered by more than 5°F above the natural temperature. At no time shall these WARM-designated waters be raised above 80°F as a result of waste discharges.”.
- g. **Total Dissolved Solids (TDS), Chloride, Sulfate, and Boron.** As discussed in section 3.4.1 of this Fact Sheet the Calleguas Creek Salts TMDL includes WLAs for boron (1.0 mg/L), chloride (150 mg/L), sulfate (250 mg/L), and TDS

(850 mg/L). Therefore, the discharge effluent limitations set forth in this permit for boron, chloride, sulfates, and TDS are based on the TMDL.

- h. **Total Inorganic Nitrogen (NO₂ +NO₃ as N).** Total inorganic nitrogen is the sum of Nitrate-nitrogen and Nitrite-nitrogen. The effluent limitation of 10 mg/L is based on Basin Plan Table 3-8 (page 3-12), for the Calleguas Creek Watershed above Potrero Road. As discussed in section 3.4.2 of this Fact Sheet, the Calleguas Creek Nitrogen TMDL did not establish WLAs for nitrogen compounds for minor NPDES discharges to the Calleguas Creek Watershed. Therefore, this permit includes effluent limitations of 10 mg/L for nitrate plus nitrite as nitrogen consistent with the Basin Plan.
- i. **Bacteria.** This Order implements the applicable numeric water quality objectives for bacteria included in the Bacteria Provisions. Given the nature of the Facility, a treatment plant that treats groundwater occasionally mixed with stormwater runoff, pathogens are not expected to be present in the effluent. Therefore, this Order implements the applicable numeric water quality objectives for bacteria as a receiving water limitation only. Effluent and receiving water monitoring for bacteria are established consistent with the requirements included in the Bacteria Provisions

4.3.3. CTR and SIP

The CTR and the SIP specify numeric objectives for toxic substances and the procedures whereby these objectives are to be implemented. The procedures include those used to conduct reasonable potential analysis (RPA) to determine the need for effluent limitations for priority pollutants. The Technical Support Document (TSD) also specifies procedures to conduct reasonable potential analyses.

The CTR contains both saltwater and freshwater criteria for the protection of aquatic life. Because a distinct separation generally does not exist between freshwater and saltwater aquatic communities, and in accordance with 40 CFR section 131.38(c)(3), freshwater criteria apply at salinities of 1 part per thousand (ppt) and below at locations where this occurs 95 percent or more of the time. Based on the salinity of the South Fork of Arroyo Conejo, the freshwater aquatic life criteria apply. The CTR also contains criteria for the protection of human health for consumption of water and organisms or consumption of organisms only. The criteria for the consumption of water and organisms does not apply because the South Fork of Arroyo Conejo only has a conditionally designated MUN designation. Therefore, the more stringent of the CTR criteria for freshwater aquatic life or for human health protection from consumption of organisms only are used to prescribe the effluent limitations in this Order.

Some water quality criteria are hardness dependent. According to the CTR, for determining freshwater aquatic life criteria for metals, the actual ambient hardness of the surface water shall be used for surface waters with a hardness of 400 mg/L or less as calcium carbonate. For surface waters with a hardness of greater than 400 mg/L as calcium carbonate, a hardness of 400 mg/L shall be used. Receiving water monitoring data for hardness submitted from 2016 through 2019 ranges

from 420 mg/L to 560 mg/L for the South Fork of Arroyo Conejo. Therefore, this permit utilized a hardness of 400 mg/L to evaluate the reasonable potential and calculate the WQBELs for hardness dependent metals (e.g., cadmium, chromium III, copper, lead, nickel, silver, and zinc).

4.3.4. Title 22 Maximum Contaminant Level (MCL)

Groundwater recharge of the underlying Conejo Valley groundwater basin is also a beneficial use for the receiving water body (GWR). The GWR beneficial use is protected using the Title 22 MCLs to protect drinking water in the Conejo Valley groundwater basin, which has a MUN beneficial use.

Table F-6 summarizes the applicable water quality criteria/objectives for priority pollutants reported in detectable concentrations in the discharges through Discharge Point No. 001 or in receiving water based on data submitted to the Los Angeles Water Board, and those that were limited in the previous Order. These criteria were used to complete the RPA for this Order.

Table F-6. Applicable Water Quality Criteria/Objectives

CTR No.	Constituent	Selected Criteria (µg/L)	CTR Acute Criteria (µg/L)	CTR Chronic Criteria (µg/L)	CTR Human Health Consumption of Organisms only Criteria (µg/L)	Title 22 Maximum Contaminant Level (MCL) (µg/L) (Note b)
2	Arsenic	10	340	150	---	10
4	Cadmium (Note a)	5	21.58	7.31	---	5
5a	Chromium (III) (Note a)	644.20	6404.62	644.2	---	---
5b	Chromium (VI)	11.43	16.29	11.43	---	---
6	Copper (Note a)	30.50	51.68	30.50	---	---
7	Lead (Note a)	18.58	476.82	18.58	---	---
8	Mercury	0.051	---	---	0.051	2
9	Nickel (Note a)	100	1515.9	168.54	---	100
10	Selenium	5	---	5	---	50
11	Silver (Note a)	44.05	44.05	---	---	---
13	Zinc (Note a)	387.83	387.83	387.83	---	---
	TCDD Equivalents	0.000000014	---	---	0.000000014	0.00003
19	Benzene	1	---	---	71	1
21	Carbon Tetrachloride	0.5	---	---	4.4	0.5
27	Dichlorobromomethane	46	---	---	46	---
28	1,1-dichloroethane	5	---	---	---	5
29	1,2-dichloroethane	0.5	---	---	99	0.5
30	1,1-Dichloroethylene	3.2	---	---	3.2	6
33	Ethylbenzene	300	---	---	---	300
38	Tetrachloroethylene	5	---	---	8.85	5
39	Toluene	150	---	---	29000	150

CTR No.	Constituent	Selected Criteria (µg/L)	CTR Acute Criteria (µg/L)	CTR Chronic Criteria (µg/L)	CTR Human Health Consumption of Organisms only Criteria (µg/L)	Title 22 Maximum Contaminant Level (MCL) (µg/L) (Note b)
40	1,2-Trans-Dichloroethylene	10	---	---	140000	10
41	1,1,1-Trichloroethane	200	---	---	---	200
43	Trichloroethylene	5	---	---	81	5
44	Vinyl Chloride	1	---	---	525	1
68	Bis(2-Ethylhexyl) Phthalate	4.0	---	---	5.9	4.0
107	Chlordane	0.00059	---	---	0.00059	0.1
108	4,4'-DDT	0.00059	---	---	0.00059	---
109	4,4'-DDE	0.00059	---	---	0.00059	---
110	4,4'-DDD	0.00084	---	---	0.00084	---
111	Dieldrin	0.00014	---	---	0.00014	---
119-125	PCBs sum (119 to125)	0.00017	---	---	0.00017	0.50
126	Toxaphene	0.00075	---	---	0.00075	3.00

Footnote for Table F-6

- a. A hardness of 400 mg/L was used to adjust the criteria for metals because the ambient hardness data submitted by the Discharger for the South Fork of Arroyo Conejo Creek from 2016 through 2019 were greater than 400 mg/L, ranging from 420 mg/L to 560 mg/L.
- b. Groundwater recharge of the underlying Conejo Valley groundwater basin is also a beneficial use for the receiving water body (GWR). The GWR beneficial use is protected using Title 22 Maximum Contaminant Levels (MCLs) to protect the GWR beneficial use.

End of Footnote to Table F-6

4.3.5. TMDLs

- a. As discussed in section 3.4.5 of this Fact Sheet, the Calleguas Creek Watershed Metals and Selenium TMDL assigned final WLAs for total recoverable copper and total recoverable nickel for both wet and dry weather for Calleguas Creek Reach 13. There was no selenium WLA developed for this Reach. The final WLA for mercury was set to 0.051 µg/L for all reaches. Table F-7 and Table F-8 summarize the applicable final WLAs contained in the TMDL that are applicable to the discharges at Discharge Point No. 001 to South Fork of Arroyo Conejo Creek.

Table F-7. Final WLAs for Total Recoverable Copper and Nickel

Parameter	Units	Effluent Limitations	
		Dry-Weather Monthly Average (Note a)	Wet-Weather Daily Maximum (Note b)
Copper, Total Recoverable (Note c)	µg/L	29.1	43.3
Nickel, Total Recoverable (Note d)	µg/L	160	1296

Footnotes for Table F-7

- a. The Dry-Weather Monthly Average effluent limits apply when flow in the receiving water (South Fork of Arroyo Conejo) is less than the 86th percentile flow rate for the reach. If flow data are unavailable for the South Fork of Arroyo Conejo, the 86th percentile flow rate (29.7 cubic feet per second (cfs)) of Calleguas Creek at PCH may be used (see Section 9.3, *Final Technical Report - Calleguas Creek Watershed Metals and Selenium TMDL*, March 29, 2006, p. 141).
- b. The Wet Weather Daily Maximum effluent limits apply when flow in the receiving water (South Fork of Arroyo Conejo) exceeds the 86th percentile flow rate for the reach. If flow data are unavailable for the South Fork of Arroyo Conejo, the 86th percentile flow rate (29.7 cfs) of Calleguas Creek at PCH may be used.
- c. The concentration-based effluent limitations are based on TMDL WLAs, which have already been converted to total recoverable using the CTR default translator of 0.96 for freshwater reaches.
- d. The concentration-based effluent limitations are based on TMDL WLAs, which have already been converted to total recoverable using the CTR default translator of 0.997 for freshwater reaches.

End of Footnotes for Table F-7

Table F-8. Final Concentration-Based WLA for Mercury

Parameter	Units	Effluent Limitations	
		Monthly Average	Daily Maximum
Mercury	µg/L	--	0.051

This permit implements the applicable WLAs for total recoverable copper, total recoverable nickel, and mercury as required in the TMDLs for Calleguas Creek, its tributaries, and Mugu Lagoon.

- b. As discussed in section 3.4.4 of this Fact Sheet, the Calleguas Creek Organochlorine Pesticides, Polychlorinated Biphenyls, and Siltation TMDL established concentration-based WLAs for organochlorine pesticides (chlordane, 4,4'-DDT, 4,4'-DDE, 4,4'-DDD, dieldrin, and toxaphene) and PCBs (total PCBs) for minor point sources, including the Facility, discharging to the

Calleguas Creek Watershed. Table F-9 summarizes the applicable concentration-based WLAs contained in the TMDL that are applicable to the discharges at Discharge Point No. 001 to the South Fork of Arroyo Conejo Creek.

Table F-9. Concentration-Based WLAs for Organochlorine Pesticides and PCBs.

Parameter	Units	Effluent Limitations	
		Monthly Average	Daily Maximum
Chlordane	µg/L	0.00059	0.0012
4,4-DDT	µg/L	0.00059	0.0012
4,4-DDE	µg/L	0.00059	0.0012
4,4-DDD	µg/L	0.00084	0.0017
Dieldrin	µg/L	0.00014	0.00028
Polychlorinated Biphenyls (PCBs)	µg/L	0.00017	0.00034
Toxaphene	µg/L	0.00016	0.00033

This permit implements the applicable WLAs for chlordane, 4,4'-DDT, 4,4'-DDE, 4,4'-DDD, dieldrin, total PCBs, and toxaphene as required in the TMDLs for Calleguas Creek, its tributaries, and Mugu Lagoon.

- c. As discussed in section 3.4.3 of this Fact Sheet, the Calleguas Creek Watershed Toxicity TMDL allocated a WLA of 1.0 TU_c and established WLAs (interim and final) for chlorpyrifos and diazinon for minor point sources, including the Facility, discharging to the Calleguas Creek Watershed. Consistent with the TMDL, the final WLA-based limit became operative on March 26, 2008. Table F-10 summarizes the applicable final WLAs contained in the TMDL that are applicable to the discharges at Discharge Point No. 001 to the South Fork of Arroyo Conejo Creek.

Table F-10. Final WLAs for Toxicity, Chlorpyrifos and Diazinon

Parameter	Units	Final Waste Load Allocations (WLAs)	
		Monthly Average	Daily Maximum
Chlorpyrifos	µg/L	0.014	0.025
Diazinon	µg/L	0.10	0.10
Toxicity, chronic (Note a)	TU _c	---	---

Footnote for Table F-10

- a. The final WLA for toxicity is 1.0 TU_c.

End of Footnote for Table F-10.

4.3.6 Determining the Need for WQBELs

The Los Angeles Water Board developed WQBELs for boron, chloride, sulfate, TDS, copper, nickel, mercury, chlordane, 4,4'-DDD, 4,4'-DDE, 4,4'-DDT, dieldrin, PCBs, toxaphene, chlorpyrifos, diazinon, and chronic toxicity that have WLAs established in TMDLs. The Los Angeles Water Board developed WQBELs for these pollutants pursuant to 40 CFR section 122.44(d)(1)(vii), which does not require or contemplate a separate reasonable potential analysis. Similarly, the SIP at Section 1.3 recognizes that a separate reasonable potential analysis at the time of permit development is not appropriate if a TMDL has been developed.

In accordance with Section 1.3 of the SIP, the Los Angeles Water Board staff conducts a reasonable potential analysis for each priority pollutant with an applicable criterion or objective to determine if a WQBEL is required in the permit. The Los Angeles Water Board staff analyzes effluent and receiving water data to determine if a pollutant in a discharge has a reasonable potential to cause or contribute to an excursion above a state water quality standard. For all parameters that demonstrate reasonable potential, numeric WQBELs are required. The RPA considers water quality criteria from the CTR and NTR, and when applicable, water quality objectives specified in the Basin Plan. To conduct the RPA, the Los Angeles Water Board staff identifies the maximum effluent concentration (MEC) and maximum background concentration in the receiving water for each constituent, based on data provided by the Discharger. Effluent and receiving water monitoring data from July 2015 through September 2020 provided by the Discharger during the term of Order No. R4-2015-0106 were used to determine reasonable potential.

Section 1.3 of the SIP provides the procedures for determining reasonable potential to exceed applicable water quality criteria and objectives. The SIP specifies three triggers to complete an RPA:

- Trigger 1 – If the MEC is greater than or equal to the CTR water quality criteria or applicable objective (C), a limitation is needed.
- Trigger 2 – If background water quality (B) > C and the pollutant is detected in the effluent, a limitation is needed.
- Trigger 3 – If other related information such as CWA 303(d) listing for a pollutant, discharge type, compliance history, then best professional judgment is used to determine that a limit is needed.

Sufficient effluent and ambient data are needed to conduct a complete RPA. If data are not sufficient, the Discharger will be required to gather the appropriate data for the Los Angeles Water Board to conduct the RPA. Upon review of the data, and if the Los Angeles Water Board determines that WQBELs are needed to protect the beneficial uses, the permit will be reopened for appropriate modification.

The RPA was performed for the priority pollutants regulated in the CTR for which data are available. Based on the RPA, pollutants that do not already have effluent limitations and demonstrate reasonable potential are TCDD equivalents and bis(2-

ethylhexyl)phthalate because the MEC is greater than the C. In addition, the previously limited pollutants that demonstrate reasonable potential based on the MEC being greater than the C are total recoverable chromium VI and trichloroethylene. The previously limited pollutants that do not demonstrate reasonable potential based on a comparison of the MEC and the C include chromium III, selenium, silver, benzene, carbon tetrachloride, 1,1-dichloroethane, 1,2-dichloroethane, 1,1-dichloroethylene, dichlorobromomethane, ethylbenzene, tetrachloroethylene, toluene, 1,2-trans-dichloroethylene, and vinyl chloride. These effluent limitations, however, are still applicable based on Trigger 3 since the influent groundwater to the treatment system includes these constituents at concentrations in the same range as the applicable water quality criteria. The constituents with effluent limitations in Order R4-2015-0106 that no longer have reasonable potential include arsenic, cadmium, lead, and 1,1,1-Trichloroethane. The following Table summarizes results from the RPA.

Table F-11. Summary of Reasonable Potential Analysis

CTR No.	Constituent	Applicable Water Quality Criteria (C) µg/L	Max Effluent Conc. (MEC) µg/L	Maximum Detected Receiving Water Conc. (B) µg/L	RPA Result – Need Limitation?	Reason
2	Arsenic	10	1.4	1.9	No	MEC<C
4	Cadmium	5	<0.25	<0.25	No	MEC<C
5a	Chromium (III)	644.20	1.3	1.4	No	MEC<C
5b	Chromium (VI)	11.43	24	3.5	Yes	MEC>C
6	Copper	30.50	11	4.3	Yes	TMDL
7	Lead	18.58	<0.5	<0.5	No	MEC<C
8	Mercury	0.051	0.022	1.4	Yes	TMDL
9	Nickel	100	2.4	4.1	Yes	TMDL
10	Selenium	5	2.4	0.56	Yes	Trigger 3 (Note a)
11	Silver	44.05	<0.5	<0.5	Yes	Trigger 3 (Note a)
13	Zinc	387.83	7.98	25	No	MEC<C
	TCDD Equivalents	1.4x10 ⁻⁸	8x10 ⁻⁷	1.7x10 ⁻⁶	Yes	MEC>C
19	Benzene	1	0.25	<0.25	Yes	Trigger 3 (Note a)
21	Carbon Tetrachloride	0.5	<0.25	<0.25	Yes	Trigger 3 (Note a)
27	Dichlorobromomethane	46	<0.25	<0.25	Yes	Trigger 3 (Note a)
28	1,1-dichloroethane	5	<0.25	<0.25	Yes	Trigger 3 (Note a)
29	1,2-dichloroethane	0.5	<0.25	<0.25	Yes	Trigger 3 (Note a)
30	1,1-Dichloroethylene	3.2	<0.25	<0.25	Yes	Trigger 3 (Note a)
33	Ethylbenzene	300	<0.25	<0.25	Yes	Trigger 3 (Note a)
38	Tetrachloroethylene	5	<0.25	<0.25	Yes	Trigger 3 (Note a)
39	Toluene	150	<0.25	<0.25	Yes	Trigger 3 (Note a)

CTR No.	Constituent	Applicable Water Quality Criteria (C) µg/L	Max Effluent Conc. (MEC) µg/L	Maximum Detected Receiving Water Conc. (B) µg/L	RPA Result – Need Limitation?	Reason
40	1,2-Trans-Dichloroethylene	10	<0.25	No value reported	Yes	Trigger 3 (Note a)
41	1,1,1-Trichloroethane	200	<0.25	<0.25	No	MEC<C
43	Trichloroethylene	5	9.7	<0.25	Yes	MEC>C
44	Vinyl Chloride	1	<0.25	<0.25	Yes	Trigger 3 (Note a)
54	Phenol	4600000	<2	<0.096	No	MEC<C
68	Bis(2-Ethylhexyl) Phthalate	4.0	67	<1.9	Yes	MEC>C
107	Chlordane	0.00059	<0.077	<0.076	Yes	TMDL
108	4,4'-DDT	0.00059	<0.0038	<0.0038	Yes	TMDL
109	4,4'-DDE	0.00059	<0.0029	<0.0029	Yes	TMDL
110	4,4'-DDD	0.00084	<0.0038	<0.0038	Yes	TMDL
111	Dieldrin	0.00014	<0.0019	<0.0019	Yes	TMDL
119-125	PCBs sum (119 to125)	0.00017	<0.24	<0.24	Yes	TMDL
126	Toxaphene	0.00016	<0.24	<0.24	Yes	TMDL
---	Chlorpyrifos	0.0133	<0.01	---	Yes	TMDL
---	Diazinon	0.1	<0.01	---	Yes	TMDL

Footnote for Table F-11

a. Present in untreated groundwater at concentrations in the range of C.

End of Footnote for Table F-11

4.3.6. WQBEL Calculations

- a. Calculation Options.** If reasonable potential exists to exceed applicable water quality criteria or objectives, then a WQBEL must be established in accordance with one or more of the three procedures contained in section 1.4 of the SIP. These procedures include:
- i. If applicable and available, use the WLA established as part of a TMDL.
 - ii. Use of a steady-state model to derive maximum daily effluent limitations (MDELs) and average monthly effluent limitations (AMELs).
 - iii. Where sufficient effluent and receiving water data exist, use of a dynamic model, which has been approved by the Los Angeles Water Board Once RPA has been conducted using either the TSD or the SIP methodologies, WQBELs are calculated. Alternative procedures for calculating WQBELs include:

b. TMDL-based Limitations

i. Calleguas Creek Watershed Metals and Selenium TMDL

The Metals and Selenium TMDL establishes concentration-based final WLAs for total recoverable copper and total recoverable nickel as both a dry-weather monthly average and a wet-weather daily maximum for Calleguas Creek Reach 13. The permit includes final effluent limitations consistent with these final WLAs.

The Metals and Selenium TMDL also include a final WLA for mercury that was set to 0.051 µg/L for other NPDES dischargers based on the CTR water column target for protection of human health from consumption of organism only. The permit contains final effluent limitations consistent with this final WLA.

The Metals and Selenium TMDL does not set WLAs for selenium in Calleguas Creek Reach 13. Therefore, the effluent limitations for selenium in the permit are based on the CTR freshwater aquatic life criteria.

ii. Calleguas Creek OC Pesticides and PCBs TMDL

The OC Pesticides and PCBs TMDL establishes final WLAs for chlordane, dieldrin, 4,4-DDD, 4,4- DDE, 4,4-DDT, PCBs, and toxaphene. The permit contains final effluent limitations consistent with these final WLAs.

iii. Calleguas Creek Watershed Toxicity, Chlorpyrifos, and Diazinon TMDL (Toxicity TMDL)

The Toxicity TMDL establishes WLAs (interim and final) for chlorpyrifos and diazinon for minor point sources discharging to the Calleguas Creek Watershed. The final WLA-based limits became operative on March 26, 2008. Therefore, the effluent limitations for chlorpyrifos and diazinon are consistent with the final WLAs in the TMDL.

The Toxicity TMDL includes a WLA for chronic toxicity of 1.0 TUc. The TMDL states that the 1.0TUc WLA shall be implemented in accordance with U.S. EPA, State Water Board, and Regional Water Board resolutions, guidance and policy at the time of permit issuance or renewal. Consistent with the Toxicity TMDL Implementation Plan, this toxicity WLA will be implemented using the recent U.S. EPA guidance, National Pollutant Discharge Elimination System Test of Significant Toxicity Implementation Document (U.S. EPA 833-R-10-003, June 2010) (see 4.3.6.f. below).

iv. Calleguas Creek Watershed Nitrogen TMDL

The Nitrogen TMDL did not establish WLAs for nitrogen compounds (ammonia, nitrite, and nitrate) for minor NPDES discharges to the Calleguas Creek Watershed. Thus, the WLAs for these constituents are not included in this Order. This Order includes effluent limitations of 10 mg/L for nitrate plus nitrite as nitrogen based on the water quality objective in the Basin Plan.

- c. In this Order, no dilution credit is being allowed. However, in accordance with the reopener provision in section 6.3.1.e in the Order, this Order may be reopened upon the submission by the Discharger of adequate information to establish appropriate dilution credits or a mixing zone, as determined by the Los Angeles Water Board
- d. **WQBELs Based on SIP Calculation Procedure.** The process for developing the effluent limitations is in accordance with Section 1.4 of the SIP. Two sets of AMEL and MDEL values are calculated separately, one set for the protection of aquatic life and the other for the protection of human health. The AMEL and MDEL limitations for aquatic life and human health are compared, and the most restrictive AMEL and the most restrictive MDEL are selected as the WQBEL. Using total recoverable chromium VI as an example, the WQBELs were calculated using the process described below:

Calculation of aquatic life AMEL and MDEL

Sample calculation for **total recoverable chromium VI**:

Step 1: For each constituent requiring an effluent limit, identify the applicable water quality criteria or objective. For each criterion, determine the effluent concentration allowance (ECA) using the following steady state equation:

$$\begin{aligned} ECA &= C + D(C-B) && \text{when } C > B, \text{ and} \\ ECA &= C && \text{when } C \leq B, \end{aligned}$$

Where C = The priority pollutant criterion/objective, adjusted if necessary for hardness, pH and translators. For discharges from the Facility, criteria for saltwater are independent of hardness and pH.

D = The dilution credit, and

B = The ambient background concentration

As discussed above, for this Order dilution was not allowed; therefore,

$$ECA = C$$

For total recoverable chromium VI:

The applicable water quality criteria (using freshwater aquatic life criteria) are:

$$ECA_{\text{acute}} = 16.29 \mu\text{g/L}$$

$$ECA_{\text{chronic}} = 11.43 \mu\text{g/L}$$

Step 2: For each ECA based on aquatic life criterion/objective, determine the long term average discharge condition (LTA) by multiplying the ECA by a factor (multiplier). The multiplier is a statistically based factor that adjusts the ECA to account for effluent variability. The value of the multiplier varies depending on the coefficient of variation (CV) of the data set and whether it is an acute or chronic criterion/objective. Table 1 of the SIP provides pre-calculated values for the multipliers based on the value of the CV. Equations to develop the multipliers in place of using values in the tables are provided in section 1.4, Step 3 of the SIP and will not be repeated here.

$$LTA_{\text{acute}} = ECA_{\text{acute}} \times \text{Multiplier}_{\text{acute}99}$$

$$LTA_{\text{chronic}} = ECA_{\text{chronic}} \times \text{Multiplier}_{\text{chronic}99}$$

The CV for the data set must be determined before the multipliers can be selected and will vary depending on the number of samples and the standard deviation of a data set. If the data set is less than 10 samples, or at least 80% of the samples in the data set are reported as non-detect, the CV shall be set equal to 0.6. If the data set is greater than 10 samples, and at least 20% of the samples in the data set are reported as detected, the CV shall be equal to the standard deviation of the data set divided by the average of the data set.

For total recoverable chromium VI, the following data were used to develop the acute and chronic LTAs using equations provided in Section 1.4, Step 3 of the SIP (Table 1 of the SIP also provides this data up to three decimals). Based on the monitoring data for chromium VI, the calculated CV of 1.7 was used in the calculation.

No. of Samples per Month	CV	ECA Multiplier _{acute}	ECA Multiplier _{chronic}
4	1.7	0.131	0.236

Total recoverable chromium VI:

$$LTA_{\text{acute}} = 16.29 \mu\text{g/L} \times 0.131 = 2.134 \mu\text{g/L}$$

$$LTA_{\text{chronic}} = 11.43 \mu\text{g/L} \times 0.236 = 2.70 \mu\text{g/L}$$

Step 3: Select the most limiting (lowest) of the LTA:

For total recoverable lead, the most limiting LTA is LTA_{chronic}

$$LTA_{\text{chronic}} = 2.134 \mu\text{g/L}$$

Step 4: Calculate the WQBELs by multiplying the LTA by a factor (multiplier). WQBELs are expressed as AMEL and MDEL. The multiplier is a statistically based factor that adjusts the LTA for the averaging periods and exceedance frequencies of the criteria/objectives and the effluent limitations. The value of the multiplier varies depending on the probability basis, the CV of the data set, the number of samples (for AMEL) and whether it is a monthly or daily limit. Table 2 of the SIP provides pre-calculated values for the multipliers based on the value of the CV and the number of samples. Equations to develop the multipliers in place of using values in the tables are provided in Section 1.4, Step 5 of the SIP and will not be repeated here

$$AMEL_{\text{aquaticlife}} = LTA \times AMEL_{\text{multiplier}95}$$

$$MDEL_{\text{aquaticlife}} = LTA \times MDEL_{\text{multiplier}99}$$

AMEL multipliers are based on a 95th percentile occurrence probability, and the MDEL multipliers are based on a 99th percentile occurrence probability. If the number of samples is less than four (4), the default number of samples to be used is four (4).

For total recoverable chromium VI, the following data were used to develop the AMEL and MDEL for effluent limitations using equations provided in section 1.4, Step 5 of the SIP.

No of Samples Per Month	CV	Multiplier _{MDEL99}	Multiplier _{AMEL95}
4	1.7	7.63	2.56

Total recoverable chromium VI based on aquatic life:

$$\text{AMEL} = 2.134 \mu\text{g/L} \times 2.56 = 5.5 \mu\text{g/L}$$

$$\text{MDEL} = 2.134 \mu\text{g/L} \times 7.63 = 16.3 \mu\text{g/L}$$

Calculation of human health AMEL and MDEL:

Step 5: For the ECA based on human health, set the AMEL equal to the ECA_{human health}:

$$\text{AMEL}_{\text{human health}} = \text{ECA}_{\text{human health}}$$

In the case of total recoverable chromium VI, there are no human health criteria. Therefore, there will be no AMEL or MDEL calculated for human health criteria.

Step 6: Calculate the MDEL for human health by multiplying the AMEL by the ratio of Multiplier_{MDEL} to the Multiplier_{AMEL}. Table 2 of the SIP provides pre-calculated ratios to be used in this calculation based on the CV and the number of samples.

$$\text{MDEL}_{\text{human health}} = \text{AMEL}_{\text{human health}} \times (\text{Multiplier}_{\text{MDEL}} / \text{Multiplier}_{\text{AMEL}})$$

Since there are no human health criteria for total recoverable chromium VI, no AMEL or MDEL are calculated for human health criteria.

Step 7: Select the lower of the AMEL and MDEL based on aquatic life and human health as the WQBEL for the Order.

For total recoverable chromium VI: Since no AMEL or MDEL calculated for human health criteria, the lowest AMEL and MDEL are based on the aquatic life protection:

$$\text{AMEL} = 5.5 \mu\text{g/L}$$

$$\text{MDEL} = 16.3 \mu\text{g/L}$$

Therefore, the effluent limitations for total recoverable chromium VI, AMEL (5.5 μg/L) and MDEL (16.3 μg/L) based on aquatic life criteria/objectives are incorporated into this permit.

Following the same process, the AMELs and MDELs for total recoverable selenium and total recoverable silver were calculated based on the CTR freshwater aquatic life criteria and the SIP procedures. For bis(2-

ethylhexyl)phthalate, the effluent limitations were established based on the Title 22 MCLs utilizing the AMEL and MDEL calculation protocol for human health criteria included in the SIP. For benzene, carbon tetrachloride, 1,1-dichloroethane, 1,2-dichloroethane, 1,1-dichloroethylene, trichloroethylene, xylene, and ethylbenzene, dichlorobromomethane, ethylbenzene, tetrachloroethylene, toluene, 1,2-trans-dichloroethylene, and vinyl chloride, the effluent limitations were based on the Title 22 MCLs and the previous permit (Order No. R4-2015-0106). The TCDD equivalents effluent limitations were established based on the human health CTR criteria and the SIP procedures. Therefore, this permit includes WQBELs for these pollutants. These limitations are expected to be protective of the beneficial uses of the receiving water.

e. Mass-based Effluent Limits

Generally, mass-based effluent limitations ensure that proper treatment, and not dilution, is employed to comply with the final effluent concentration limitations. 40 CFR § 122.45(f)(1) requires that all permit limitations, standards or prohibitions be expressed in terms of mass units except under the following conditions: (1) for pH, temperature, radiation or other pollutants that cannot appropriately be expressed by mass limitations; (2) when applicable standards or limitations are expressed in terms of other units of measure; or (3) if, in establishing technology-based permit limitation on a case-by-case basis, limitations based on mass are infeasible because the mass or pollutant cannot be related to a measure of production.

Mass-based effluent limitations are established using the following formula:

Mass (pounds/day) = flow rate (MGD) x 8.34 x effluent limitation (mg/L)

Where: Mass = mass limitation for a pollutant (pounds/day)

Effluent limitation = concentration limit for a pollutant (mg/L)

Flow rate = discharge flow rate (MGD).

According to the Report of Waste Discharge submitted by the Discharger, the maximum flow is 0.110 MGD at Discharge Point 001. The mass-based effluent limitations are calculated using this flow.

f. Whole Effluent Toxicity (WET)

Whole effluent toxicity (WET) protects the receiving water quality from the aggregate toxic effect of a mixture of pollutants in the effluent. WET tests measure the degree of response of exposed aquatic test organisms to an effluent. The WET approach allows for protection of the narrative “no toxics in toxics amounts” objective while implementing numeric criteria for toxicity. There are two types of WET tests: acute and chronic. An acute toxicity test is conducted over a short time and measures mortality. A chronic toxicity test is conducted over a longer period of time and may measure mortality, reproduction and growth.

The Basin Plan includes a narrative objective for toxicity, requiring that all waters be maintained free of toxic substances in concentrations that are lethal

to or produce other detrimental responses in aquatic organisms. Detrimental responses include, but are not limited to, decreased growth rate, decreased reproductive success of resident or indicator species, and/or significant alterations in population, community ecology, or receiving water biota.

In addition to the Basin Plan requirements, section 4 of the SIP states that a chronic toxicity effluent limitation is required in permits for all discharges that will cause, have the reasonable potential to cause, or contribute to chronic toxicity in receiving waters. Discharges from TFX Aviation, Inc. Facility enter the South Fork of Arroyo Conejo Creek. The Calleguas Creek Toxicity TMDL (Resolution No. R4-2005-009) allocated a chronic toxicity WLA of 1.0 TU_c for the Calleguas Creek, its tributaries, and Mugu Lagoon. Because a chronic toxicity TMDL WLA is applicable to the discharge, a WQBEL based on this WLA is required (40 CFR section 122.44(d)(1)(vii)(B)) and implemented using the recent USEPA guidance, National Pollutant Discharge Elimination System Test of Significant Toxicity Implementation Document (EPA 833-R-10-003, June 2010).

In June 2010, U.S. EPA published a guidance document titled *National Pollutant Discharge Elimination System Test of Significant Toxicity Implementation Document* (EPA 833-R-10-003, June 2010), in which they recommend the following: “Permitting authorities should consider adding the TST approach to their implementation procedures for analyzing valid WET data for their current NPDES WET Program.” The TST statistical approach is another statistical option for analyzing valid WET test data. Use of the TST statistical approach does not result in any changes to EPA’s WET test methods. Section 9.4.1.2 of U.S. EPA’s *Short-term Methods for Estimating the Chronic Toxicity of Effluents and Receiving Waters to West Coast Marine and Estuarine Organisms* (EPA/600/R-95/0136, 1995), recognizes that, “the statistical methods recommended in this manual are not the only possible methods of statistical analysis.” The TST statistical approach can be applied to acute (survival) and chronic (sublethal) endpoints and is appropriate to use for both freshwater and marine EPA WET test methods.

The TST’s null hypothesis for chronic toxicity is:

$$H_0: \text{Mean response (IWC in \% effluent)} \leq 0.75 \text{ mean response (Control).}$$

Results obtained from the chronic toxicity test are analyzed using the TST statistical approach and an acceptable level of chronic toxicity is demonstrated by rejecting the null hypothesis and reporting “Pass” or “P”. Chronic toxicity results are expressed as “Pass” or “Fail” and “% Effect”. Since no dilution is allowed, the chronic toxicity IWC for Discharge Point 001 is 100 percent effluent

The previous Order No. R4-2015-0106 included chronic toxicity effluent limitations expressed as “Pass” for the median monthly summary results and “Pass” and “<50% Effect” for each maximum daily individual result. These chronic toxicity effluent limitations are as stringent as necessary to protect the narrative Basin Plan Water Quality Objective for chronic toxicity. Those limitations are also consistent with the chronic toxicity WLA of 1.0 TU_c and the

assumptions of the Calleguas Creek Toxicity TMDL which went into effect on March 24, 2006. The chronic toxicity in the discharge is evaluated using U.S. EPA's 2010 Test of Significant Toxicity (TST) hypothesis testing statistical approach.

The Facility demonstrate reasonable potential for chronic toxicity. Monitoring data for chronic toxicity tests reported between July 2015 and September 2020 indicated one "Fail" result in 2016 for chronic toxicity. Therefore, this Order includes chronic toxicity effluent limitations at discharge location EFF-001. This Order also establishes a chronic toxicity accelerated monitoring trigger defined as a test result of "Fail" for the TST approach. Nevertheless, this Order contains a reopener to allow the Los Angeles Water Board to modify the permit in the future, if necessary, to make it consistent with any new policy, plan, law, or regulation.

4.4. Final Effluent Limitation Considerations

4.4.1. Anti-Backsliding Requirements

Sections 402(o) and 303(d)(4) of the CWA and federal regulations at 40 CFR § 122.44(l) prohibit backsliding in NPDES permits. These anti-backsliding provisions require effluent limitations in a reissued permit to be as stringent as those in the previous permit, with some exceptions where limitations may be relaxed. All effluent limitations in this Order are at least as stringent as the effluent limitations in Order No. R4-2015-0106 with the exception of those discussed below

a. Total Recoverable Selenium

Pursuant to CWA section 303(d)(4)(B), a WQBEL may be relaxed for discharges to receiving waters that are in attainment for the pollutants as long as the action complies with the state's antidegradation policy.

The average monthly effluent limitation (AMEL) in this Order is less stringent and the maximum daily effluent limitation (MDEL) is more stringent than that in the prior Order No. R4-2015-0106. The change to the AMEL is a result of a recalculation of the total recoverable selenium effluent limitations using monitoring data collected during the prior permit term rather than a default value. The CTR-SIP procedure accounts for variability in the effluent data using a "coefficient of variation" (CV). Where there is insufficient data, a CV value of 0.6 is used (see Step 3 in § 1.4.B of the SIP). When the prior Order No. R4-2015-0106 was adopted, there were insufficient data to calculate the CV, however, this time a CV value of 0.38 was calculated based on the total recoverable selenium monitoring data (July 2015 through September 2020). The newly established effluent limitations for total recoverable selenium are more representative of the discharge. In this permit, the calculated effluent limitations for AMEL = 4.4 µg/L and MDEL = 7.2 µg/L based on the CV of 0.38 indicate that the AMEL is less stringent but the MDEL is more stringent than the limitations in Order No. R4-2015-0106 (AMEL = 4.1 µg/L; MDEL = 8.2 µg/L based on CV = 0.6). Although the new AMEL is less stringent than the prior order, the relaxation of this objective is consistent with the exceptions to backsliding in section 304(d)(B) of the CWA because the effluent will not result in a violation of any applicable criteria or water quality objective in the receiving water

into which the effluent discharges. The maximum effluent concentration in the discharge reported for total recoverable selenium of 2.4 µg/L was below the new AMEL and MDEL, and the water quality objective. The quality of the water equals or exceeds levels necessary to protect the designated uses, and it meets water quality standards for selenium. Further, as required for attainment waters, the revision is consistent with antidegradation policies, as set forth below. Thus, the revision is justified under section 303(d)(4)(B). Nonetheless, this Order retains effluent monitoring for this pollutant, in accordance with the SIP.

b. Arsenic, cadmium, lead, and 1,1,1-Trichloroethane

The South Fork of Arroyo Conejo Creek is an attainment water for arsenic, cadmium, lead and 1,1,1-Trichloroethane. Section 303(d)(4)(B) of the CWA allows for a WQBEL to be relaxed for discharges to receiving water as long as the action complies with the state's antidegradation policy. In the order preceding the current order (Order No. R4-2009-0096), effluent limitations for Volatile Organic Compounds and metals were included because of the nature of the groundwater treatment operation and the lack of influent concentrations to the groundwater treatment system, and were not based on a reasonable potential analysis. Now that the groundwater data is available, it is appropriate to remove any effluent limitations for constituents that do not show reasonable potential and are not present in the groundwater in the range of the water quality criteria.

Arsenic effluent monitoring data collected from July 2015 through September 2020 indicated a maximum effluent concentration of 1.4 µg/L that was less than the applicable water quality criteria (10 µg/L). The effluent monitoring data collected from July 2015 through September 2020 was evaluated for reasonable potential in accordance with SIP procedures. Since the MEC was less than C and there is no justification for Trigger 3, there was no reasonable potential for detected concentrations of arsenic to cause or contribute to an exceedance of a water quality objective.

The effluent monitoring data collected from July 2015 through September 2020 indicated non-detect (ND) for cadmium (<0.25 µg/L), lead (<0.5 µg/L), and 1,1,1-trichloroethane (<0.25 µg/L). These results are based on the recent data and indicate there was no reasonable potential for cadmium, lead, and 1,1,1-trichloroethane to exceed the water quality criteria.

The receiving water into which the effluent discharges is an attainment water for arsenic, cadmium, lead, and 1,1,1-trichloroethane. The quality of the water equals or exceeds levels necessary to protect the designated uses, and it meets water quality standards for arsenic, cadmium, lead, and 1,1,1-trichloroethane. Further, the revision of these WQBELs is consistent with antidegradation policies, as set forth below. Because there is no reasonable potential for arsenic, cadmium, lead, and 1,1,1-trichloroethane, relaxation of the effluent limitations will not result in a violation of any applicable criteria or water quality objective. Thus, the revision is justified under CWA 303(d)(4)(B). Nonetheless, this Order retains effluent monitoring for these pollutants, in accordance with the SIP.

4.4.2. Antidegradation Policies

40 CFR section 131.12 requires that the state water quality standards include an antidegradation policy consistent with the federal policy. The State Water Board established California's antidegradation policy in State Water Board Resolution 68-16. Resolution 68-16 incorporates the federal antidegradation policy where the federal policy applies under federal law. Resolution 68-16 requires that existing water quality be maintained unless degradation is justified based on specific findings. The Los Angeles Water Board's Basin Plan and the SIP implement, and incorporate by reference, both the state and federal antidegradation policies. This Order is consistent with the state and federal antidegradation policies as follows:

The new AMEL for total recoverable selenium will not result in degradation to receiving waters because, as discussed above, the new AMEL for total recoverable selenium was calculated based on a coefficient of variation (CV) value of 0.38 rather than the default value in accordance with the CTR-SIP procedures. The AMEL is still protective of beneficial uses and will not result in exceedances of the applicable water quality objectives. Additionally, the MDEL is more stringent than in the prior permit. As such, the discharge will not degrade the receiving water quality.

This Order also removes effluent limitations for arsenic, cadmium, lead, and 1,1,1-trichloroethane. These limits were incorporated into the 2009 order since groundwater data was not available at the time. However, as discussed in Section 4.4.1. above, the concentrations of arsenic (detected), cadmium (not detected), lead (not detected), and 1,1,1-trichloroethane (not detected) did not demonstrate reasonable potential to cause or contribute to an excursion above water quality objectives. In addition, the final limitations in this Order for other constituents, which include concentration-based and mass-based limitations, hold the Discharger to performance levels that will not adversely impact the beneficial uses or degrade the water quality of the receiving water and are developed consistent with applicable effluent criteria, the protocol established to calculate effluent limitations and state regulations

Further, this Order does not provide for an increase in the permitted design flow or allow for a reduction in the level of treatment. The limits included hold the Discharger to performance levels that will not cause or contribute to water quality impairment or water quality degradation. The final limitations in this Order, which include concentration-based and mass-based limitations, hold the Discharger to performance levels that will not adversely impact the beneficial uses or degrade the water quality of the receiving water and are developed consistent with applicable effluent criteria, the protocol established to calculate effluent limitations, and state regulations. Compliance with these requirements will result in the use of best practicable treatment or control of the discharge. Therefore, the issuance of this permit is consistent with the state's antidegradation policy.

4.4.3. Stringency of Requirements for Individual Pollutants

This Order contains both technology-based and water quality-based effluent limitations for individual pollutants. The technology-based effluent limitations consist of restrictions on BOD, oil and grease, and TSS at Discharge Point 001. Restrictions

on these parameters are discussed in section 4.2.2 of this Fact Sheet. This Order’s technology-based pollutant restrictions implement the minimum, applicable federal technology-based requirements.

Water quality-based effluent limitations have been derived to implement water quality objectives that protect beneficial uses. Both the beneficial uses and the water quality objectives have been approved pursuant to federal law and are the applicable federal water quality standards. To the extent that toxic pollutant water quality-based effluent limitations were derived from the CTR, the CTR is the applicable standard pursuant to 40 CFR section 131.38. The procedures for calculating the individual water quality-based effluent limitations for priority pollutants are based on the CTR implemented by the SIP, which was approved by U.S. EPA on May 18, 2000. Most beneficial uses and water quality objectives contained in the Basin Plan were approved under state law and submitted to and approved by U.S. EPA prior to May 30, 2000. Any water quality objectives and beneficial uses submitted to U.S. EPA prior to May 30, 2000, but not approved by U.S. EPA before that date, are nonetheless “applicable water quality standards for purposes of the CWA” pursuant to 40 CFR section 131.21(c)(1). The remaining water quality objectives and beneficial uses implemented by this Order were approved by U.S. EPA and are applicable water quality standards pursuant to section 131.21(c)(2). Collectively, this Order’s restrictions on individual pollutants are no more stringent than required to implement the requirements of the CWA.

4.4.4. Summary of Final Effluent Limitations

Table F-12. Summary of Final Effluent Limitations at Discharge Point 001

Parameter	Units (Note a)	Average Monthly	Maximum Daily	Basis (Note b)
Biochemical Oxygen Demand (BOD ₅ 20°C)	mg/L	20	30	E, BPJ
(BOD ₅ 20°C)	lbs/day	18	28	E, BPJ
Total Suspended Solids (TSS)	mg/L	50	75	E, BPJ
TSS	lbs/day	46	69	E, BPJ
Oil and Grease	mg/L	10	15	E, BPJ, GB
Oil and Grease	lbs/day	9	14	E, BPJ, GB
pH	Standard unit	---	---	E, BP, and Note c
Temperature	°F	---	80	BP, and Note d
Settleable Solids	mL/L	0.1	0.2	E, BPJ
Turbidity	NTU	50	75	E, BPJ
Sulfides	mg/L	---	1	E, BPJ
Sulfides	lbs/day	---	0.92	E, BPJ
Sulfate	mg/L	---	250	TMDL, E
Sulfate	lbs/day	---	229	TMDL, E
Boron	mg/L	---	1.0	TMDL, E
Boron	lbs/day	---	0.92	TMDL, E

Parameter	Units (Note a)	Average Monthly	Maximum Daily	Basis (Note b)
Chloride	mg/L	---	150	TMDL, E
Chloride	lbs/day	---	138	TMDL, E
Total Dissolved Solids	mg/L	---	850	TMDL, E
Total Dissolved Solids	lbs/day	---	780	TMDL, E
Nitrate + Nitrite as N	mg/L	---	10	E, BP
Nitrate+ Nitrite as N	lbs/day	---	9.2	E, BP
Phenols	mg/L	---	1	E, BPJ
Phenols	lbs/day	---	0.92	E, BPJ
Chronic Toxicity	Pass or Fail and % Effect for TST approach	Pass	Pass or % Effect <50	BP, E
Chromium VI, TR	µg/L	5.5	16.3	CTR SIP, and Note e
Chromium VI, TR	lbs/day	0.005	0.015	CTR SIP, and Note e
Mercury, TR	µg/L	---	0.051	TMDL, E
Mercury, TR	lbs/day	---	0.00005	TMDL, E
Selenium, TR	µg/L	4.4	7.2	CTR, SIP, and Note f
Selenium, TR	lbs/day	0.004	0.007	CTR, SIP, and Note f
Silver, TR	µg/L	22	44	CTR, SIP
Silver, TR	lbs/day	0.02	0.04	CTR, SIP
TCDD Equivalents	µg/L	1.40E-08	2.80E-08	CTR, SIP
TCDD Equivalents	lbs/day	1.30E-11	2.60E-11	CTR, SIP
Trichloroethylene	µg/L	---	5	E, MCL
Trichloroethylene	lbs/day	--	0.005	E, MCL
Benzene	µg/L	---	1	E, MCL
Benzene	lbs/day	---	0.0009	E, MCL
Toluene	µg/L	---	10	E, MCL,
Toluene	lbs/day	---	0.009	E, MCL,
Xylene	µg/L	---	10	E, MCL
Xylene	lbs/day	---	0.009	E, MCL
Ethylbenzene	µg/L	---	10	E, MCL
Ethylbenzene	lbs/day	---	0.009	E, MCL
Dichlorobromomethane	µg/L	---	100	E, MCL
Dichlorobromomethane	lbs/day	---	0.092	E, MCL
Carbon Tetrachloride	µg/L	---	0.5	E, MCL
Carbon Tetrachloride	lbs/day	---	0.0005	E, MCL
1,1-Dichloroethane	µg/L	---	5	E, MCL
1,1-Dichloroethane	lbs/day	---	0.005	E, MCL

Parameter	Units (Note a)	Average Monthly	Maximum Daily	Basis (Note b)
1,2-Dichloroethane	µg/L	---	0.5	E, MCL
1,2-Dichloroethane	lbs/day	---	0.0005	E, MCL
1,1-Dichloroethylene	µg/L	---	6	E, MCL
1,1-Dichloroethylene	lbs/day	---	0.006	E, MCL
Trans1,2-Dichloroethylene	µg/L	---	10	E, MCL
Trans1,2-Dichloroethylene	lbs/day	---	0.009	E, MCL
Tetrachloroethylene	µg/L	---	5	E, MCL
Tetrachloroethylene	lbs/day	---	0.005	E, MCL
Vinyl Chloride	µg/L	---	0.5	E, MCL
Vinyl Chloride	lbs/day	---	0.0005	E, MCL
Bis(2-Ethylhexyl)Phthalate	µg/L	4	8	CTR, SIP
Bis(2-Ethylhexyl)Phthalate	lbs/day	0.004	0.007	CTR, SIP
Chlordane	µg/L	0.0006	0.001	TMDL, E
Chlordane	lbs/day	0.0000005	0.000001	TMDL, E
4,4-DDD	µg/L	0.0008	0.002	TMDL, E
4,4-DDD	lbs/day	0.0000008	0.000002	TMDL, E
4,4-DDE	µg/L	0.0006	0.001	TMDL, E
4,4-DDE	lbs/day	0.0000005	0.000001	TMDL, E
4,4-DDT	µg/L	0.0006	0.0012	TMDL, E
4,4-DDT	lbs/day	0.0000005	0.000001	TMDL, E
Dieldrin	µg/L	0.0001	0.0003	TMDL, E
Dieldrin	lbs/day	0.0000001	0.0000003	TMDL, E
Polychlorinated Biphenyls (PCBs)	µg/L	0.0002	0.0003	TMDL, E
PCBs	lbs/day	0.0000002	0.0000003	TMDL, E
Toxaphene	µg/L	0.0002	0.0003	TMDL, E
Toxaphene	lbs/day	0.0000002	0.0000003	TMDL, E
Phenolic Compounds (Chlorinated)	µg/L	---	1	E, BPJ
Phenolic Compounds (Chlorinated)	lbs/day	---	0.00092	E, BPJ
Chlorpyrifos	µg/L	0.014	0.025	TMDL, E
Chlorpyrifos	lbs/day	0.00001	0.00002	TMDL, E
Diazinon	µg/L	0.10	0.10	TMDL, E
Diazinon	lbs/day	0.00009	0.00009	TMDL, E

Footnotes for Table F-12

- a. The mass (lbs/day) limitations are based on a maximum flow of 0.110 MGD and are calculated as follows:

$$\text{mass} \left(\frac{\text{lbs}}{\text{day}} \right) = \text{Flow}(\text{MGD}) \times \text{Concentration} \left(\frac{\text{mg}}{\text{L}} \right) \times 8.34 \text{ (conversion factor)}$$

- b. Abbreviations of Basis for Effluent Limitations:
 E = Existing Order No. R4-2015-0106; BP = Basin Plan;
 BPJ = Best Professional Judgment; GB = U.S. EPA Gold Book;
 CTR = California Toxic Rule; SIP = State Implementation Policy;
 TMDL = Total Maximum Daily Load (Calleguas Creek Watershed TMDL)
 MCL = Title 22 Maximum Contaminant Level.
- c. The effluent limitations for pH are 6.5 as an Instantaneous Minimum and 8.5 as an Instantaneous Maximum.
- d. The effluent limitation for temperature is 80°F based on the water quality objective in the Basin Plan for temperature that is applicable to inland surface waters with WARM beneficial use designation such as the South Fork of Arroyo Conejo Creek. The applicable water quality objective (WQO) states: "For waters designated WARM, water temperature shall not be altered by more than 5 °F above the natural temperature. At no time shall these WARM-designated waters be raised above 80 °F as a result of waste discharges."
- e. The effluent limitations of chromium VI were established based on a coefficient of variation (CV) value of 1.7 (calculated based on the 2015 through 2020 monitoring data) and using the CTR-SIP procedures.
- f. The effluent limitations of selenium were established based on a coefficient of variation (CV) value of 0.38 (calculated based on the 2015 through 2020 monitoring data) and using the CTR-SIP procedures.

End of Footnotes for Table F-12

Table F-13. Final Effluent Limitations for Copper and Nickel at Discharge Point 001

Parameter	Units	Dry-Weather Monthly Average (Note a)	Wet-Weather Daily Maximum (Note b)	Basis (Note c)
Copper, Total Recoverable (TR)	µg/L	29.1	43.3	TMDL, E, and Note d
Copper, TR	lbs/day	0.03	0.04	TMDL, E, and Note e
Nickel, TR	µg/L	160	1296	TMDL, E, and Note f
Nickel, TR	lbs/day	0.2	1.2	TMDL, E, and Note e

Footnotes for Table 13

- a. The Dry-Weather Monthly Average effluent limits apply when flow in the receiving water is less than the 86th percentile flow rate for the South Fork of Arroyo Conejo. If flow data are unavailable

for the South Fork of Arroyo Conejo, the 86th percentile flow rate (29.7 cubic feet per second (cfs)) for Calleguas Creek at PCH shall be used, see Section 9.3 Final Technical Report Calleguas Creek Watershed Metals and Selenium TMDL, Revised May 2006, p.142..

- b. The Wet-Weather Daily Maximum effluent limits apply when flow in the receiving water exceeds the 86th percentile flow rate.
- c. Abbreviations of Basis for Effluent Limitations:
E = Existing Order No. R4-2015-0106
TMDL = Total Maximum Daily Load (*Calleguas Creek Watershed Metals and Selenium TMDL*)
- d. The concentration-based effluent limitations are based on TMDL WLAs, which have already been converted to total recoverable using the CTR default translator of 0.96 for freshwater reaches.
- e. The mass-based (lbs/day) effluent limitations for pollutants are based on a maximum discharge flow rate of 0.110 MGD and are calculated as follows:
$$\text{Flow (mgd)} \times \text{Concentration (mg/L)} \times 8.34 \text{ (conversion factor)} = \text{lbs/day.}$$
- f. The concentration-based effluent limitations are based on TMDL WLAs, which have already been converted to total recoverable using the CTR default translator of 0.997 for freshwater reaches.

End of Footnotes for Table 13

4.5. Interim Effluent Limitations – Not Applicable

4.6. Land Discharge Specifications – Not Applicable

4.7. Recycling Specifications – Not Applicable

5. RATIONALE FOR RECEIVING WATER LIMITATIONS

5.1. Surface Water

The receiving water limitations in the proposed Order are based upon the water quality objectives contained in the Basin Plan and statewide water quality control plans. As such, they are a required part of the proposed Order.

5.2. Groundwater

Limitations in this Order must protect not only surface receiving water beneficial uses, but also the beneficial uses of underlying groundwater where there is a groundwater recharge (GWR) beneficial use of the surface water. There is a GWR beneficial use for the South Fork of the Arroyo Conejo due to the MUN designation for the underlying Conejo Valley groundwater basin. This Order contains MCLs effluent limitations to protect the GWR beneficial use.

6. RATIONALE FOR PROVISIONS

6.1. Standard Provisions

Standard Provisions, which apply to all NPDES permits in accordance with 40 CFR section 122.41, and additional conditions applicable to specified categories of permits in accordance with 40 CFR section 122.42, are provided in Attachment D. The Discharger must comply with all standard provisions and with those additional conditions that are applicable under section 122.42.

Sections 122.41(a)(1) and (b) through (n) of 40 CFR establish conditions that apply to all state-issued NPDES permits. These conditions must be incorporated into the permits either expressly or by reference. If incorporated by reference, a specific citation to the regulations must be included in the Order. Section 123.25(a)(12) of 40 CFR

allows the state to omit or modify conditions to impose more stringent requirements. In accordance with 40 CFR section 123.25, this Order omits federal conditions that address enforcement authority specified in 40 CFR sections 122.41(j)(5) and (k)(2) because the enforcement authority under the Water Code is more stringent. In lieu of these conditions, this Order incorporates by reference Water Code section 13387(e).

6.2. Special Provisions

6.2.1. Reopener Provisions

These provisions are based on 40 CFR part 123 and Order No. R4-2015-0106. The Los Angeles Water Board may reopen the permit to modify permit conditions and requirements. Causes for modifications include the promulgation of new federal regulations, modification in toxicity requirements, or adoption of new regulations by the State Water Board or Los Angeles Water Board, including revisions to the Basin Plan.

6.2.2. Special Studies and Additional Monitoring Requirements

Initial Investigation Toxicity Reduction Evaluation (TRE) Workplan. This provision is based on section 4 of the SIP, Toxicity Control Provisions, which establishes minimum toxicity control requirements for implementing the narrative toxicity objective for aquatic life protection established in the basin plans of the State of California.

6.2.3. Best Management Practices and Pollution Prevention

This provision is based on section 122.44(k) and includes the requirement to update and continue to implement the SWPPP, BMPP, and Spill Contingency Plan (SCP). This Order requires the Discharger to report on the effectiveness of the plans and update them as needed to ensure all actual or potential sources of pollutants in wastewater discharged from the Facility are addressed in the SWPPP, BMP, and Spill Contingency Plan.

6.2.4. Construction, Operation, and Maintenance Specifications

This provision is based on the requirements of 40 CFR section 122.41(e) and the previous order.

6.2.5. Other Special Provisions (Not Applicable)

7. RATIONALE FOR MONITORING AND REPORTING REQUIREMENTS

CWA section 308 and 40 CFR sections 122.41(h), (j)-(l), 122.44(i), and 122.48 require that all NPDES permits specify monitoring and reporting requirements. Water Code section 13383 also authorizes the Los Angeles Water Board to establish monitoring, inspection, entry, reporting, and recordkeeping requirements. The Monitoring and Reporting Program (MRP), Attachment E of this Order establishes monitoring, reporting, and recordkeeping requirements that implement federal and state requirements. The following provides the rationale for the monitoring and reporting requirements contained in the MRP for this facility.

7.1. Influent Monitoring

Influent monitoring is required to determine compliance with NPDES permit conditions and assess the effectiveness and performance of the treatment system.

7.2. Effluent Monitoring

Monitoring for pollutants expected to be present in the discharge are required as established in the MRP (Attachment E) and as required in the SIP. To demonstrate compliance with established effluent limitations, the Order retains the monitoring requirements from Order No. R4-2015-0106, except for bis(2-ethylhexyl)phthalate, and TCDD equivalents for which the monitoring frequency was changed from once per year to once per quarter. For bis(2-ethylhexyl)phthalate, if the results are non-detect for two years, the Discharger may submit a request for the monitoring frequency to be decreased to annually with Executive Officer approval.

In addition, monitoring for *E. coli* is required to be consistent with the requirements included in the Bacteria Provisions. For arsenic, cadmium, lead, and 1,1,1-trichloroethane, the monitoring frequency was changed from once per quarter to twice per year. Monitoring for cis-1,2-Dichloroethylene for once per quarter is added to determine reasonable potential.

The SIP states that the Los Angeles Water Board will require periodic monitoring for pollutants for which criteria or objectives apply and for which no effluent limitations have been established. This Order requires the Discharger to conduct annual monitoring for the remaining CTR priority pollutants. The Los Angeles Water Board will use the additional data to conduct an RPA and determine if additional WQBELs are required. The Los Angeles Water Board may reopen the permit to incorporate additional effluent limitations and requirements, if necessary.

7.3. Whole Effluent Toxicity Testing Requirements

Whole effluent toxicity (WET) protects the receiving water quality from the aggregate toxic effect of a mixture of pollutants in the effluent. An acute toxicity test is conducted over a short time period and measures mortality. A chronic toxicity test is conducted over a longer period of time and may measure mortality, reproduction, and growth. This Order includes chronic toxicity monitoring requirements.

7.4. Receiving Water Monitoring

7.4.1. Surface Water

This Order includes receiving water limitations and therefore monitoring requirements are included in the MRP to determine compliance with the receiving water limitations established in Section 5.1 of the Order.

According to the SIP, the Discharger is required to monitor the upstream receiving water for the CTR priority pollutants to determine reasonable potential. Accordingly, this permit requires the Discharger to conduct receiving water monitoring of the CTR priority pollutants at Monitoring Location RSW-001. The Discharger must analyze temperature, hardness, and pH of the upstream receiving water at the same time the samples are collected for priority pollutants analysis. This Order requires receiving water monitoring for *E. coli* to determine reasonable potential. The Discharger is also required to collect stream flow data at RSW-001 in the South Fork of Arroyo Conejo to determine compliance with the effluent limitations for copper and nickel based on the TMDL.

The Ventura County Watershed Protection District (VCWPD) requires the public to obtain permission to access the channel or perform any activity in the channel. Also, VCWPD has expressed some concerns associated with the placement of equipment in the flood control channel to monitor for flow.

Based on the information provided by VCWPD to the Los Angeles Water Board, stream flow data is monitored at a gauging station in the South Fork of Arroyo Conejo (Station No. 830), which is closest to RSW-001. This station can record stream flow (not real time data) above 25 cubic feet per second (cfs), which is reflective of the stream flow during rain events. During the dry season the flow is between 10 to 15 cfs. The low flow data (25 to 100 cfs) are not posted on the VCWPD website but the public can obtain the data through a letter of request. TFX shall request the stream flow data from VCWPD for compliance with the NPDES permit requirements. Furthermore, TFX shall coordinate with VCWPD to obtain permission to access the channel of the South Fork of Arroyo Conejo to collect the receiving water samples for priority pollutants, pH, temperature, and hardness at RSW-001.

7.4.2. Groundwater – Not Applicable

7.5. Other Monitoring Requirements

7.5.1. Storm Water Monitoring - Not Applicable

7.5.2. SWPPP, BMP, and Spill Contingency Plan Status and Effectiveness Report

The Discharger is required by Special Provision 6.3.3. of the Order to update and implement a SWPPP, BMP, and Spill Contingency Plan. This Order requires the Discharger to report on the effectiveness of the plans and update them as needed to ensure all actual or potential sources of pollutants in wastewater discharged from the Facility are addressed in the SWPPP, BMP, and Spill Contingency Plan.

8. PUBLIC PARTICIPATION

The Los Angeles Water Board has considered the issuance of WDRs that will serve as an NPDES permit for the TFX Aviation, Inc. As a step in the WDR adoption process, the Los Angeles Water Board staff has developed tentative WDRs and has encouraged public participation in the WDR adoption process.

8.1. Notification of Interested Parties

The Los Angeles Water Board notified the Discharger and interested agencies and persons of its intent to prescribe WDRs for the discharge and provided an opportunity to submit written comments and recommendations. Notification was provided through the following:

The public had access to the agenda and any changes in dates and locations through the Los Angeles Water Board's website at <http://www.waterboards.ca.gov/losangeles/>.

8.2. Written Comments

Interested persons were invited to submit written comments concerning tentative WDRs as provided through the notification process. Comments were due either in person or by

mail to the Executive Office at the Los Angeles Water Board at the address on the cover page of this Order, or by email submitted to losangeles@waterboards.ca.gov with a copy to rosario.aston@waterboards.ca.gov.

To be fully responded to by staff and considered by the Los Angeles Water Board, the written comments were due at the Los Angeles Water Board office by **5:00 p.m. on May 14, 2021**.

8.3. Public Hearing

The Los Angeles Water Board held a public hearing on the tentative WDRs during its regular Board meeting on the following date and time and at the following location:

Date: June 10, 2021
Time: 09:00 a.m.
Location: Remote meeting; no physical location

Interested persons were invited to attend. At the public hearing, the Los Angeles Water Board heard testimony pertinent to the discharge, WDRs, and permit. For accuracy of the record, important testimony was requested in writing.

8.4. Reconsideration of Waste Discharge Requirements

Any person aggrieved by this action of the Los Angeles Water Board may petition the State Water Board to review the action in accordance with Water Code section 13320 and California Code of Regulations, title 23, sections 2050 and following. The State Water Board must receive the petition by 5:00 p.m., within 30 calendar days of the date of adoption of this Order at the following address, except that if the thirtieth day following the date of this Order falls on a Saturday, Sunday, or state holiday, the petition must be received by the State Water Board by 5:00 p.m. on the next business day:

State Water Resources Control Board
Office of Chief Counsel
P.O. Box 100, 1001 I Street
Sacramento, CA 95812-0100
Or by email at waterqualitypetitions@waterboards.ca.gov

For instructions on how to file a petition for review, see:
http://www.waterboards.ca.gov/public_notices/petitions/water_quality/wgpetition_instr.s.html

8.5. Information and Copying

The Report of Waste Discharge, other supporting documents, and comments received are on file and may be inspected at the address above by appointment between 8:30 a.m. and 4:45 p.m., Monday through Friday. Inspection and copying of documents may be arranged through the Los Angeles Water Board at the address below or by emailing losangeles@waterboards.ca.gov

Los Angeles Regional Water Quality Control Board
320 W. 4th Street, Suite 200
Los Angeles, CA 90013-2343

The tentative WDRs, comments received and response to comments are also available on the Los Angeles Water Board's website at:

http://www.waterboards.ca.gov/losangeles/board_decisions/tentative_orders/index.shtml

8.6. Register of Interested Persons

Any person interested in being placed on the mailing list for information regarding the WDRs and NPDES permit should contact the Los Angeles Water Board, reference this facility, and provide a name, address, and phone number.

8.7. Additional Information

Requests for additional information or questions regarding this order should be directed to Rosario Aston at rosario.aston@waterboards.ca.gov or at .(213) 576-6653.

ATTACHMENT G - STORMWATER POLLUTION PREVENTION PLAN REQUIREMENTS

1. IMPLEMENTATION SCHEDULE

A storm water pollution prevention plan (SWPPP) shall be developed and submitted to the Regional Water Board within 90 days following the adoption of this Order. The SWPPP shall be implemented for each facility covered by this Permit within 10 days of approval from the Regional Water Board, or no later than 90 days from the date of the submittal of the SWPPP to the Regional Water Board (whichever comes first).

2. OBJECTIVES

The SWPPP has two major objectives: (a) to identify and evaluate sources of pollutants associated with industrial activities that may affect the quality of stormwater discharges and authorized non-stormwater discharges from the facility; and (b) to identify and implement site-specific best management practices (BMPs) to reduce or prevent pollutants associated with industrial activities in stormwater discharges and authorized non-stormwater discharges. BMPs may include a variety of pollution prevention measures or other low-cost and pollution control measures. They are generally categorized as non-structural BMPs (activity schedules, prohibitions of practices, maintenance procedures, and other low-cost measures) and as structural BMPs (treatment measures, run-off controls, over-head coverage). To achieve these objectives, facility operators should consider the five-phase process for SWPPP development and implementation as shown in Table A.

The SWPPP requirements are designed to be sufficiently flexible to meet the needs of various facilities. SWPPP requirements that are not applicable to a facility should not be included in the SWPPP.

A facility's SWPPP is a written document that shall contain a compliance activity schedule, a description of industrial activities and pollutant sources, descriptions of BMPs, drawings, maps, and relevant copies or references of parts of other plans. The SWPPP shall be revised whenever appropriate and shall be readily available for review by facility employees or Regional Water Board inspectors

3. PLANNING AND ORGANIZATION

3.1. Pollution Prevention Team

The SWPPP shall identify a specific individual or individuals and their positions within the facility organization as members of a stormwater pollution prevention team responsible for developing the SWPPP, assisting the facility manager in SWPPP implementation and revision, and conducting all monitoring program activities. The SWPPP shall clearly identify the General Permit related responsibilities, duties, and activities of each team member. For small facilities, stormwater pollution prevention teams may consist of one individual where appropriate.

3.2. Review Other Requirements and Existing Facility Plans

The SWPPP may incorporate or reference the appropriate elements of other regulatory requirements. Facility operators should review all local, state, and federal requirements that impact, complement, or are consistent with the requirements of this permit. Facility operators should identify any existing facility

plans that contain storm water pollutant control measures or relate to the requirements of this Permit. As examples, facility operators whose facilities are subject to federal Spill Prevention Control and Countermeasures' requirements should already have instituted a plan to control spills of certain hazardous materials. Similarly, facility operators whose facilities are subject to air quality related permits and regulations may already have evaluated industrial activities that generate dust or particulates.

**TABLE A
 FIVE PHASES FOR DEVELOPING AND IMPLEMENTING INDUSTRIAL
 STORM WATER POLLUTION PREVENTION PLANS**

Phase	Tasks
Planning and Organization	Form Pollution Prevention Team Review other plans
Assessment Phase	Develop a site map Identify potential pollutant sources Inventory of materials and chemicals List significant spills and leaks Identify non-storm water discharges Assess pollutant risks
Best management Practices Identification Phase	Non-structural BMPs Structural BMPs Select activity and site-specific BMPs
Implementation Phase	Train employees Implement BMPs Conduct recordkeeping and reporting
Evaluation/Monitoring	Conduct annual site evaluation Review monitoring information Evaluate BMPs Review and revise SWPPP

4. SITE MAP

The SWPPP shall include a site map. The site map shall be provided on an 8-½ x 11 inch or larger sheet and include notes, legends, and other data as appropriate to ensure that the site map is clear and understandable. If necessary, facility operators may provide the required information on multiple site maps.

The following information shall be included on the site map:

- 4.1. The facility boundaries; the outline of all storm water drainage areas within the facility boundaries; portions of the drainage area impacted by run-on from surrounding areas; and direction of flow of each drainage area, on-site surface water bodies, and areas of soil erosion. The map shall also identify nearby water bodies (such as rivers, lakes, and ponds) and municipal storm drain inlets where the facility's storm water discharges and authorized non-storm water discharges may be received.
- 4.2. The location of the storm water collection and conveyance system, associated points of discharge, and direction of flow. Include any structural control measures that affect storm water discharges, authorized non-storm water discharges, and run-on. Examples of structural control measures are catch basins, berms, detention ponds, secondary containment, skim ponds, diversion barriers, etc.
- 4.3. An outline of all impervious areas of the facility, including paved areas, buildings, covered storage areas, or other roofed structures.
- 4.4. Locations where materials are directly exposed to precipitation and the locations where significant spills or leaks identified in section 6.1.4. below have occurred.
- 4.5. Areas of industrial activity. This shall include the locations of all storage areas and storage tanks, shipping and receiving areas, fueling areas, vehicle and equipment storage/maintenance areas, material handling and processing areas, waste treatment and disposal areas, dust or particulate generating areas, cleaning and rinsing areas, and other areas of industrial activity which are potential pollutant sources.

5. LIST OF SIGNIFICANT MATERIALS

The SWPPP shall include a list of significant materials¹ handled and stored at the site. For each material on the list, describe the locations where the material is being stored, received, shipped, and handled, as well as the typical quantities and frequency. Materials shall include raw materials, intermediate products, final or finished products, recycled materials, and waste or disposed materials

6. DESCRIPTION OF POTENTIAL POLLUTANT SOURCES

The SWPPP shall include a narrative description of the facility's industrial activities, as identified in section 4.5. above, associated potential pollutant sources, and potential pollutants that could be discharged in storm water discharges or authorized non-storm water discharges. At a minimum, the following items related to a facility's industrial activities shall be considered:

¹ "Significant materials" includes, but is not limited to: raw materials; fuels; materials such as solvents, detergents, and plastic pellets; finished materials such as metallic products; raw materials used in food processing or production; hazardous substances designated under section 101(14) of Comprehensive Environmental Response, Compensation, and Liability Act (CERCLA); any chemical the facility is required to report pursuant to section 313 of Title III of Superfund Amendments and Reauthorization Act (SARA); fertilizers; pesticides; and waste products such as ashes, slag, and sludge that have the potential to be released with storm water discharges.

- 6.1. **Industrial Processes.** Describe each industrial process, the type, characteristics, and quantity of significant materials used in or resulting from the process, and a description of the manufacturing, cleaning, rinsing, recycling, disposal, or other activities related to the process.
- 6.2. **Material Handling and Storage Areas.** Describe each handling and storage area, type, characteristics, and quantity of significant materials handled or stored, description of the shipping, receiving, and loading procedures, and the spill or leak prevention and response procedures. Where applicable, areas protected by containment structures and the corresponding containment capacity shall be described.
- 6.3. **Dust and Particulate Generating Activities.** Describe all industrial activities that generate dust or particulates that may be deposited within the facility's boundaries and identify their discharge locations; the characteristics of dust and particulate pollutants; the approximate quantity of dust and particulate pollutants that may be deposited within the facility boundaries; and a description of the primary areas of the facility where dust and particulate pollutants would settle.
- 6.4. **Significant Spills and Leaks.** Describe materials that have spilled or leaked in significant quantities in storm water discharges or authorized non-storm water discharges since April 17, 1994. Include toxic chemicals (listed in 40 Code of Federal Regulations (CFR), part 302) that have been discharged to storm water as reported on U.S. Environmental Protection Agency (U.S. EPA) Form R, and oil and hazardous substances in excess of reportable quantities (see 40 CFR, parts 110, 117, and 302).

The description shall include the type, characteristics, and approximate quantity of the material spilled or leaked, the cleanup or remedial actions that have occurred or are planned, the approximate remaining quantity of materials that may be exposed to storm water or non-storm water discharges, and the preventative measures taken to ensure spill or leaks do not reoccur. Such list shall be updated as appropriate during the term of this Permit.

- 6.5. **Non-Storm Water Discharges.** Facility operators shall investigate the facility to identify all non-storm water discharges and their sources. As part of this investigation, all drains (inlets and outlets) shall be evaluated to identify whether they connect to the storm drain system.

All non-storm water discharges shall be described. This shall include the source, quantity, frequency, and characteristics of the authorized non-storm water discharges and associated drainage area.

Non-storm water discharges that are not authorized by this Permit, other waste discharge requirements, or other NPDES permits are prohibited. The SWPPP must include BMPs to prevent or reduce contact of authorized non-storm water discharges with significant materials (as defined in Footnote 1 of section 5 above) or equipment.

- 6.6. **Soil Erosion.** Describe the facility locations where soil erosion may occur as a result of industrial activity, storm water discharges associated with industrial activity, or authorized non-storm water discharges.

- 6.7. Trash. Describe the facility locations where trash may be generated as a result of facility operations and on-site activities.

The SWPPP shall include a summary of all areas of industrial activities, potential pollutant sources, and potential pollutants. This information should be summarized similarly to Table B. The last column of Table B, "Control Practices", should be completed in accordance with section 8. below.

7. ASSESSMENT OF POTENTIAL POLLUTANT SOURCES

The SWPPP shall include a narrative assessment of all industrial activities and potential pollutant sources as described in section 6 above to determine:

- 7.1. Which areas of the facility are likely sources of pollutants in stormwater discharges and authorized non-stormwater discharges, and
- 7.2. Which pollutants are likely to be present in stormwater discharges and authorized non-stormwater discharges. Facility operators shall consider and evaluate various factors when performing this assessment such as current stormwater BMPs; quantities of significant materials handled, produced, stored, or disposed of; likelihood of exposure to stormwater or authorized non-storm water discharges; history of spill or leaks; and run-on from outside sources.

Facility operators shall summarize the areas of the facility that are likely sources of pollutants and the corresponding pollutants that are likely to be present in stormwater discharges and authorized non-stormwater discharges.

Facility operators are required to develop and implement additional BMPs as appropriate and necessary to prevent or reduce pollutants associated with each pollutant source.

8.. STORMWATER BEST MANAGEMENT PRACTICES

The SWPPP shall include a narrative description of the stormwater BMPs to be implemented at the facility for each potential pollutant and its source identified in the site assessment phase (Sections 6 and 7 above). The BMPs shall be developed and implemented to reduce or prevent pollutants in stormwater discharges and authorized non-stormwater discharges. Each pollutant and its source may require one or more BMPs. Some BMPs may be implemented for multiple pollutants and their sources, while other BMPs will be implemented for a very specific pollutant and its source.

TABLE B
EXAMPLE

ASSESSMENT OF POTENTIAL POLLUTION SOURCES AND
CORRESPONDING BEST MANAGEMENT PRACTICES
SUMMARY

Area	Activity	Pollutant Source	Pollutant	Best Management Practices
Vehicle & Equipment Fueling	Fueling	Spill and leaks during delivery. Spills caused by topping off fuel tanks. Hosing or washing down fuel oil fuel area. Leaking storage tanks. Rainfall running off fuel oil, and rainfall running onto and off fueling area.	Fuel oil	Use spill and overflow protection Minimize run-on of storm water into the fueling area. Cover fueling area. Use dry cleanup methods rather than hosing down area. Implement proper spill prevention control program. Implement adequate preventative maintenance program to preventive tank and line leaks. Inspect fueling areas regularly to detect problems before they occur. Train employees on proper fueling, cleanup, and spill response techniques.

The description of the BMPs shall identify the BMPs as (1) existing BMPs, (2) existing BMPs to be revised and implemented, or (3) new BMPs to be implemented. The description shall also include a discussion on the effectiveness of each BMP to reduce or prevent pollutants in stormwater discharges and authorized non-stormwater discharges. The SWPPP shall provide a summary of all BMPs implemented for each pollutant source similar to Table B.

Facility operators shall consider the following BMPs for implementation at the facility:

8.1. Non-Structural BMPs

Non-structural BMPs generally consist of processes, prohibitions, procedures, schedule of activities, etc., that prevent pollutants associated with industrial activity from contacting with stormwater discharges and authorized non-stormwater discharges. They are considered low technology, cost-effective measures. Facility operators should consider all possible non-structural BMPs before considering additional structural BMPs (see section 8.2). Below is a list of non-structural BMPs that should be considered:

- A. Good Housekeeping.** Consists of practical procedures to maintain a clean and orderly facility.

- B. Preventive Maintenance.** Includes the regular inspection and maintenance of structural stormwater controls (catch basins, oil/water separators, etc.) as well as other facility equipment and systems.
- C. Spill Response.** Includes spill clean-up procedures and necessary clean-up equipment based upon the quantities and locations of significant materials that may spill or leak.
- D. Material Handling and Storage.** Includes all procedures to minimize the potential for spills and leaks and to minimize exposure of significant materials to stormwater and authorized non-storm water discharges.
- E. Employee Training.** Includes training of personnel who are responsible for (1) implementing activities identified in the SWPPP, (2) conducting inspections, sampling, and visual observations, and (3) managing stormwater. Training should address topics such as spill response, good housekeeping, and material handling procedures, and actions necessary to implement all BMPs identified in the SWPPP. The SWPPP shall identify periodic dates for such training. Records shall be maintained of all training sessions held.
- F. Waste Handling/Recycling.** This includes the procedures or processes to handle, store, or dispose of waste materials or recyclable materials.
- G. Recordkeeping and Internal Reporting.** Includes the procedures to ensure that all records of inspections, spills, maintenance activities, corrective actions, visual observations, etc., are developed, retained, and provided, as necessary, to the appropriate facility personnel.
- H. Erosion Control and Site Stabilization.** Includes a description of all sediment and erosion control activities. This may include the planting and maintenance of vegetation, diversion of run-on and runoff, placement of sandbags, silt screens, or other sediment control devices, etc.
- I. Inspections.** This includes, in addition to the preventative maintenance inspections identified above, an inspection schedule of all potential pollutant sources. Tracking and follow-up procedures shall be described to ensure adequate corrective actions are taken and SWPPPs are made.
- J. Quality Assurance.** Includes the procedures to ensure that all elements of the SWPPP and Monitoring Program are adequately conducted.

8.2. Structural BMPs

When non-structural BMPs as identified above are ineffective, structural BMPs shall be considered. Structural BMPs generally consist of structural devices that reduce or prevent pollutants in stormwater discharges and authorized non-stormwater discharges. Below is a list of potential structural BMPs:

- A. Overhead Coverage.** Includes structures that provide horizontal coverage of materials, chemicals, and pollutant sources from contact with stormwater and authorized non-stormwater discharges.
- B. Retention Ponds.** Includes basins, ponds, surface impoundments, bermed areas, etc. that do not allow storm water to discharge from the facility.

- C. Control Devices.** This includes berms or other devices that channel or route run-on and runoff away from pollutant sources.
- D. Secondary Containment Structures.** Includes containment structures around storage tanks and other areas for the purpose of collecting any leaks or spills.
- E. Treatment.** Includes inlet controls, infiltration devices, oil/water separators, detention ponds, vegetative swales, etc. that reduce the pollutants in stormwater discharges and authorized non-stormwater discharges.

9. Annual Comprehensive Site Compliance Evaluation

The Facility operator shall conduct one comprehensive site compliance evaluation each year. The SWPPP shall be revised, as appropriate, and submitted to the Regional Water Board along with the annual monitoring report. The revisions shall be implemented no later than 90 days after submission. The evaluation is subject to review by the Regional Water Board Executive Officer and modifications may be required. Evaluations shall include the following:

- 9.1. A review of all visual observation records, inspection records, and sampling and analysis results.
- 9.2. A visual inspection of all potential pollutant sources for evidence of, or the potential for, pollutants entering the drainage system.
- 9.3. A review and evaluation of all BMPs (both structural and non-structural) to determine whether the BMPs are adequate, properly implemented and maintained, or whether additional BMPs are needed. A visual inspection of equipment needed to implement the SWPPP, such as spill response equipment, shall be included.
- 9.4. An evaluation report that includes, (i) identification of personnel performing the evaluation, (ii) the date(s) of the evaluation, (iii) necessary SWPPP revisions, (iv) schedule, as required in section 10.E., for implementing SWPPP revisions, (v) any incidents of non-compliance and the corrective actions taken, and (vi) a certification that the facility operator is in compliance with this Permit. If the above certification cannot be provided, explain in the evaluation report why the facility operator is not in compliance with this Permit. The evaluation report shall be submitted as part of the annual report, retained for at least five years, and signed and certified in accordance with Standard Provisions 5.4.5 of Attachment D.

10. SWPPP GENERAL REQUIREMENTS

- 10.1. The SWPPP shall be retained onsite and made available upon request of a representative of the Los Angeles Water Board and/or local stormwater management agency (local agency) which receives the stormwater discharges.
- 10.2. The Los Angeles Water Board and/or local agency may notify the facility operator when the SWPPP does not meet one or more of the minimum requirements of this Section. As requested by the Los Angeles Water Board and/or local agency, the facility operator shall submit an SWPPP revision and implementation schedule that meets the minimum requirements of this section to the Los Angeles Water Board and/or local agency that requested the SWPPP revisions. Within 14 days after implementing the required SWPPP revisions, the facility operator shall provide

written certification to the Los Angeles Water Board and/or local agency that the revisions have been implemented.

- 10.3. The SWPPP shall be revised, as appropriate, and implemented prior to changes in industrial activities which (i) may significantly increase the quantities of pollutants in stormwater discharge, (ii) cause a new area of industrial activity at the facility to be exposed to storm water, or (iii) begin an industrial activity which would introduce a new pollutant source at the facility.
- 10.4. The SWPPP shall be revised and implemented in a timely manner, but in no case more than 90 days after a facility operator determines that the SWPPP is in violation of any requirement(s) of this Order.
- 10.5. When any part of the SWPPP is infeasible to implement by the deadlines specified in this Order due to proposed significant structural changes, the facility operator shall submit a report to the Los Angeles Water Board prior to the applicable deadline that (i) describes the portion of the SWPPP that is infeasible to implement by the deadline, (ii) provides justification for a time extension, (iii) provides a schedule for completing and implementing that portion of the SWPPP, and (iv) describes the BMPs that will be implemented in the interim period to reduce or prevent pollutants in stormwater discharges and authorized non-stormwater discharges. Such reports are subject to Los Angeles Water Board approval and/or modifications. Facility operators shall provide written notification to the Los Angeles Water Board within 14 days after the SWPPP revisions are implemented.
- 10.6. The SWPPP shall be provided, upon request, to the Los Angeles Water Board. The SWPPP is considered a report that shall be available to the public by the Los Angeles Water Board under Section 308(b) of the Clean Water Act.