

North Coast Regional Water Quality Control Board

**ORDER NO. R1-2019-0006
NPDES NO. CA0022713
WDID NO. 1B82114OHUM**

WASTE DISCHARGE REQUIREMENTS

FOR THE

**CITY OF ARCATA
WASTEWATER TREATMENT FACILITY
HUMBOLDT COUNTY**

The following Permittee is subject to waste discharge requirements (WDRs) set forth in this Order:

Table 1. Permittee Information

Permittee	City of Arcata
Name of Facility	Wastewater Treatment Facility
Facility Address	600 South G Street
	Arcata, CA 95521
	Humboldt County
Type of Facility	Publicly Owned Treatment Works (POTW)
Facility Design Flow	2.3 million gallons per day (mgd) (average dry weather design flow) 5.0 mgd (average wet weather design flow) 5.9 mgd (peak wet weather design flow) 16.5 mgd (wet weather Q _{max})

Table 2. Discharge Locations

Discharge Point	Effluent Description	Discharge Point Latitude (North)	Discharge Point Longitude (West)	Receiving Water
001	Equivalent to secondary treated wastewater	40° 51' 18"	124° 5' 26"	Humboldt Bay
002	Secondary treated wastewater	40° 51' 29"	124° 5' 31"	Arcata Marsh Wildlife Sanctuary
003	Secondary treated wastewater	40° 51' 40"	124° 5' 37"	Brackish Marsh, Humboldt Bay

Table 3. Administrative Information

This Order was adopted on:	October 17, 2019
This Order shall become effective on:	December 1, 2019
This Order shall expire on:	November 30, 2024
The Permittee shall file a Report of Waste Discharge as an application for reissuance of WDRs in accordance with title 23, California Code of Regulations, (CCR) and an application for reissuance of a National Pollutant Discharge Elimination System (NPDES) permit no later than:	December 1, 2023
The U.S. Environmental Protection Agency (U.S. EPA) and the California Regional Water Quality Control Board, North Coast Region have classified this discharge as follows:	Major

IT IS HEREBY ORDERED, that Waste Discharge Requirements (WDR) Order No. R1-2012-0031 and Monitoring and Reporting Program (MRP) No. R1-2012-0031, are rescinded upon the effective date of this Order except for enforcement purposes, and in order to meet the provisions contained in division 7 of the California Water Code (Water Code) (commencing with section 13000) and regulations and guidelines adopted thereunder, and the provisions of the federal Clean Water Act (CWA) and regulations and guidelines adopted thereunder, the Permittee shall comply with the requirements of this Order. This action in no way prevents the North Coast Regional Water Quality Control Board (Regional Water Board) from taking enforcement action for past violations of the previous permit.

I, Matthias St. John, Executive Officer, do hereby certify that this Order with all attachments is a full, true, and correct copy of the Order adopted by the California Regional Water Quality Control Board, North Coast Region, on **October 17, 2019**.

 Matthias St. John, Executive Officer

19_0006_Arcata_NPDES

Contents

I. Facility Information..... 4
 II. Findings..... 4
 III. Discharge Prohibitions 5
 IV. Effluent Limitations and Discharge Specifications..... 6
 V. Receiving Water Limitations 14
 A. Surface Water Limitations 14
 B. Groundwater Limitations 16
 VI. Provisions..... 17
 A. Standard Provisions..... 17
 B. Monitoring and Reporting Program (MRP) Requirements..... 18
 C. Special Provisions..... 18
 VII. Compliance Determination 28

Tables

Table 1. Permittee Information 1
 Table 2. Discharge Locations..... 1
 Table 3. Administrative Information..... 2
 Table 4. Effluent Limitations – Discharge Point 001 6
 Table 5. Effluent Limitations – Discharge Point 001 7
 Table 6. Effluent Limitations – Discharge Point 003 9
 Table 7. Effluent Limitations – Discharge Point 002 10
 Table 8. Effluent Limitations – Discharge Point 003 11
 Table 9. Discharge Specifications – Discharge Point 002 12

Attachments

Attachment A – Definitions A-1
 Attachment B – Location Map B-1
 Attachment C – Flow Schematic C-1
 Attachment D – Standard Provisions D-1
 Attachment E – Monitoring and Reporting Program (MRP) E-1
 Attachment F – Fact Sheet F-1
 Attachment G - AMEL and MDEL Ammonia Standards based on the 1989 Saltwater acute criteria G-1
 Attachment H – PDF Example of the AIR Calculator H-1

I. FACILITY INFORMATION

Information describing the City of Arcata (Permittee) Wastewater Treatment Facility (Facility) is summarized in Table 1 and in sections I and II of the Fact Sheet (Attachment F). Section I of the Fact Sheet also includes information regarding the Facility's permit application.

II. FINDINGS

The California Regional Water Quality Control Board, North Coast Region (Regional Water Board), finds:

- A. Legal Authorities.** This Order serves as Waste Discharge Requirements (WDRs) pursuant to article 4, chapter 4, division 7 of the Water Code (commencing with section 13260). This Order is also issued pursuant to section 402 of the federal Clean Water Act (CWA) and implementing regulations adopted by the U.S. Environmental Protection Agency (U.S. EPA) and chapter 5.5, division 7 of the Water Code (commencing with section 13370). It shall serve as a National Pollutant Discharge Elimination System (NPDES) permit authorizing the Permittee to discharge into waters of the United States at the discharge locations described in Table 2 subject to WDRs in this Order.
- B. Basis and Rationale for Requirements.** The Regional Water Board developed the requirements in this Order based on information submitted as part of the Permittee's application, monitoring and reporting programs, and other available information. The Fact Sheet (Attachment F), which contains background information and rationale for the requirements in this Order, is hereby incorporated into this Order, and constitutes Findings for this Order. Attachments A through E, G and H are also incorporated into this Order.
- C. Provisions and Requirements Implementing State Law.** The provisions/requirements in subsections III.E, III.F, IV.B, IV.C, IV.D, V.B, VI.C.5.a, VI.C.5.c.ix and x, and VI.C.5.d of this Order and section X.E of the Monitoring and Reporting Program (MRP) are included to implement state law only. These provisions/requirements are not required or authorized under the federal CWA; consequently, violations of these provisions/requirements are not subject to the enforcement remedies that are available for NPDES violations.
- D. Notification of Interested Parties.** The Regional Water Board has notified the Permittee and interested agencies and persons of its intent to prescribe WDRs for the discharge and has provided them with an opportunity to submit their written comments and recommendations. Details of the notification are provided in the Fact Sheet.
- E. Consideration of Public Comment.** The Regional Water Board, in a public meeting, heard and considered all comments pertaining to the discharge. Details of the Public Hearing are provided in the Fact Sheet.

III. DISCHARGE PROHIBITIONS

- A. The discharge of waste to Humboldt Bay is prohibited unless the discharge is consistent with State Water Resources Control Board (State Water Board) Order No. 79-20 and Regional Water Board Resolution No. 83-9.
- B. The discharge of any waste not disclosed by the Permittee or not within the reasonable contemplation of the Regional Water Board is prohibited.
- C. Creation of pollution, contamination, or nuisance, as defined by section 13050 of the Water Code is prohibited.
- D. The discharge of sludge or digester supernatant is prohibited, except as authorized under section VI.C.5.c of this Order (Sludge Disposal and Handling Requirements).
- E. The discharge of untreated or partially treated waste (receiving a lower level of treatment than described in section II.B of the Fact Sheet) from anywhere within the collection, treatment, or disposal systems is prohibited, except as provided for in Attachment D, Standard Provisions G (Bypass) and H (Upset).
- F. Any sanitary sewer overflow (SSO) that results in a discharge of untreated or partially treated wastewater to (a) waters of the state or (b) land and creates pollution, contamination, or nuisance, as defined in Water Code section 13050(m) is prohibited.
- G. The discharge of waste at any point not described in Finding II.B of the Fact Sheet or authorized by a permit issued by the State Water Board or another Regional Water Board is prohibited.
- H. The average dry weather flow of waste through the Facility shall not exceed 2.3 million gallons per day (mgd), measured daily and averaged over a calendar month. Compliance with this prohibition shall be determined as defined in sections VII.K of this Order.
- I. The discharge of treated effluent at Discharge Point 001 is prohibited¹, other than that portion of the flow exceeding peak flows of 5.9 mgd that cannot be stored on-site.
- J. The discharge of any radiological, chemical, or biological warfare agent into waters of the state is prohibited under Water Code section 13375.
- K. The acceptance of septage is prohibited unless the Permittee has a septage receiving station approved by the Executive Officer of the Regional Water Board.

¹ Discharge Prohibition III.I shall take effect upon completion of Phase I of the Proposed Upgrade Project which includes construction of Discharge Point 003 to the Brackish Marsh.

IV. EFFLUENT LIMITATIONS AND DISCHARGE SPECIFICATIONS

A. Effluent Limitations – Discharge Point 001 (Prior to completion of Phase One and Phase Two of the Upgrade Project)

1. Final Effluent Limitations – Discharge Point 001

- a. The discharge of treated wastewater shall maintain compliance with the following effluent limitations at Discharge Point 001, with compliance measured at Monitoring Location EFF-001, as described in the MRP (Attachment E). These limitations apply until Phase One of the Upgrade Project is complete. Time Schedule Order No R1-2019-0011 has a compliance date for Phase One of June 30, 2022.

Table 4. Effluent Limitations – Discharge Point 001 (Prior to completion of Phase One and Phase Two of the Upgrade Project)

Parameter	Units	Effluent Limitations ¹				
		Average Monthly	Average Weekly	Maximum Daily	Instantaneous Minimum	Instantaneous Maximum
pH	standard units	--	--	--	6.0	8.5
Cyanide, Total (as CN)	µg/L	0.43	--	1.0	--	--
TCDD-Equivalents	µg/L	1.4 x 10 ⁻⁸	--	3.3 x 10 ⁻⁸	--	--
Chlorine, Total Residual	mg/L	0.01	--	0.02	--	--
Settleable Solids	ml/L	0.1	--	0.2	--	--

Table Notes:
 1. See Definitions in Attachment A and Compliance Determination discussion in section VII of this Order.

- b. **Percent Removal.** The average monthly percent removal of BOD₅ and TSS shall not be less than 85 percent. Percent removal shall be determined from the monthly average value of influent wastewater concentration in comparison to the monthly average value of effluent concentration for the same constituent over the same time period, as measured at Monitoring Locations INF-001 and EFF-001, respectively.
- c. **Disinfection.** Disinfected effluent discharged from the Facility through Discharge Point 001 to Humboldt Bay shall not contain fecal coliform bacteria exceeding the following concentrations, as measured at Monitoring Location EFF-001:
 - i. The median concentration shall not exceed a Most Probable Number (MPN) of 14 per 100 milliliters (mL) using the bacteriological results of the last calendar month for which analyses have been completed¹; and
 - ii. The number of fecal coliform bacteria shall not exceed an MPN of 43 per 100 mL in more than 10% of samples in any calendar month.
- d. **Acute Toxicity.** There shall be no acute toxicity in treated wastewater discharged to Humboldt Bay. The Permittee will be considered in compliance with this limitation

¹ See section VII.H of this Order regarding compliance with bacteriological limitations.

when the survival of aquatic organisms in a 96-hour bioassay of undiluted effluent complies with the following:

- i. Minimum for any one bioassay: 70 percent survival; and
- ii. Median for any three or more consecutive bioassays: at least 90 percent survival.

Compliance with this effluent limitation shall be determined in accordance with section VII.I of this Order and section V.A of the MRP (Attachment E).

B. Effluent Limitations – Discharge Points 001 and 003 (After Completion of Phase One of the Upgrade Project)

1. Final Effluent Limitations – Discharge Point 001

- a. The discharge of treated wastewater shall maintain compliance with the following effluent limitations at Discharge Point 001, with compliance measured at Monitoring Location EFF-001, as described in the MRP (Attachment E). These limitations apply only to flows permitted in accordance with Discharge Prohibition III.I

Table 5. Effluent Limitations – Discharge Point 001 (After Completion of Phase One of the Upgrade Project)

Parameter	Units	Effluent Limitations ¹				
		Average Monthly	Average Weekly	Maximum Daily	Instantaneous Minimum	Instantaneous Maximum
Biochemical Oxygen Demand 5-day @ 20°C (BOD ₅)	mg/L	38	57	--	--	--
Total Suspended Solids (TSS)	mg/L	32	48	--	--	--
pH	standard units	--	--	--	6.0	8.5
Cyanide, Total (as CN)	µg/L	0.43	--	1.0	--	--
TCDD-Equivalents	µg/L	1.4 x 10 ⁻⁸	--	3.3 x 10 ⁻⁸	--	--
Ammonia Impact Ratio ³	Ratio	1.0 ²	--	1.0 ²	--	--
Settleable Solids	ml/L	0.1	--	0.2	--	--

Table Notes:

1. See Definitions in Attachment A and Compliance Determination discussion in section VII of this Order.
2. The Ammonia Impact Ratio (AIR) is calculated as the ratio of the ammonia concentration in the effluent and the applicable ammonia standard (AMEL and MDEL). Attachment H is a PDF example of the calculator that will be sent to the Permittee to determine compliance with the AMEL/MDEL AIR. For each of the applicable ammonia standards, Attachment G includes two tables that provide the variable AMEL and MDEL ammonia standards used in calculating the AIR. The AIR is the ammonia effluent limit and must be reported in the self-monitoring reports in addition to ammonia, pH, salinity and temperature values. Monitoring for ammonia, pH, salinity and temperature must be conducted concurrently in order for the AIR to be calculated properly. Compliance determination will be based on the receiving water data and ammonia effluent data taken on the same day.
3. See sections VII.L and VII.M of this Order regarding compliance with each AIR effluent limitation.

- b. Percent Removal.** The average monthly percent removal of BOD₅ and TSS shall not be less than 65 percent. Percent removal shall be determined from the monthly average value of influent wastewater concentration in comparison to the monthly average value of effluent concentration for the same constituent over the same time period, as measured at Monitoring Locations INF-001 and EFF-001, respectively.
- c. Disinfection.** Disinfected effluent discharged from the Facility through Discharge Point 001 to Humboldt Bay shall not contain fecal coliform bacteria exceeding the following concentrations, as measured at Monitoring Location EFF-001:
 - i.** The median concentration shall not exceed a Most Probable Number (MPN) of 14 per 100 milliliters (mL) using the bacteriological results of the last calendar month for which analyses have been completed¹; and
 - ii.** The number of fecal coliform bacteria shall not exceed an MPN of 43 per 100 mL in more than 10% of samples in any calendar month.
- d. Acute Toxicity.** There shall be no acute toxicity in treated wastewater discharged to Humboldt Bay. The Permittee will be considered in compliance with this limitation when the survival of aquatic organisms in a 96-hour bioassay of undiluted effluent complies with the following:
 - i.** Minimum for any one bioassay: 70 percent survival; and
 - ii.** Median for any three or more consecutive bioassays: at least 90 percent survival.

Compliance with this effluent limitation shall be determined in accordance with section VII.I of this Order and section V.A of the MRP (Attachment E).

2. Final Effluent Limitations – Discharge Point 003

- a.** The discharge of treated wastewater shall maintain compliance with the following effluent limitations at Discharge Point 003, with compliance measured at Monitoring Location EFF-003 as described in the MRP (Attachment E). Time Schedule Order No R1-2019-0011 has a compliance date for Phase One of June 30, 2022.

¹ See section VII.H of this Order regarding compliance with bacteriological limitations.

Table 6. Effluent Limitations – Discharge Point 003 (After Completion of Phase One of the Upgrade Project)

Parameter	Units	Effluent Limitations ¹				
		Average Monthly	Average Weekly	Maximum Daily	Instantaneous Minimum	Instantaneous Maximum
Biochemical Oxygen Demand 5-day @ 20°C (BOD ₅)	mg/L	30	45	--	--	--
Total Suspended Solids (TSS)	mg/L	30	45	--	--	--
pH	standard units	--	--	--	6.0	8.5
Copper, Total Recoverable	µg/L	3.3	--	5.3	--	--
Cyanide, Total (as CN)	µg/L	0.43	--	1.0	--	--
TCDD-Equivalents	µg/L	1.4 x 10 ⁻⁸	--	3.3 x 10 ⁻⁸	--	--
Ammonia Impact Ratio ³	Ratio	1.0 ²	--	1.0 ²	--	--
Settleable Solids	ml/L	0.1	--	0.2	--	--

Table Notes:

- See Definitions in Attachment A and Compliance Determination discussion in section VII of this Order.
- The Ammonia Impact Ratio (AIR) is calculated as the ratio of the ammonia concentration in the effluent and the applicable ammonia standard (AMEL and MDEL). Attachment H is a PDF example of the calculator that will be sent to the Permittee to determine compliance with the AMEL/MDEL AIR. For each of the applicable ammonia standards, Attachment G includes two tables that provide the variable AMEL and MDEL ammonia standards used in calculating the AIR. The AIR is the ammonia effluent limit and must be reported in the self-monitoring reports in addition to ammonia, pH, salinity and temperature values. Monitoring for ammonia, pH, salinity and temperature must be conducted concurrently in order for the AIR to be calculated properly. Compliance determination will be based on the receiving water data and ammonia effluent data taken on the same day.
- See sections VII.L and VII.M of this Order regarding compliance with each AIR effluent limitation.

- b. Percent Removal.** The average monthly percent removal of BOD₅ and TSS shall not be less than 85 percent. Percent removal shall be determined from the monthly average value of influent wastewater concentration in comparison to the monthly average value of effluent concentration for the same constituent over the same time period, as measured at Monitoring Locations INF-001 and EFF-003, respectively.
- c. Disinfection.** Disinfected effluent discharged from the Facility through Discharge Point 003 to the Brackish Marsh shall not contain fecal coliform bacteria exceeding the following concentrations, as measured at Monitoring Location INT-001:
 - i.** The median concentration shall not exceed a Most Probable Number (MPN) of 14 per 100 milliliters (mL) using the bacteriological results of the last calendar month for which analyses have been completed¹; and

¹ See section VII.H of this Order regarding compliance with bacteriological limitations.

ii. The number of fecal coliform bacteria shall not exceed an MPN of 43 per 100 mL in more than 10% of samples in any calendar month.

d. **Acute Toxicity.** There shall be no acute toxicity in treated wastewater discharged to Humboldt Bay. The Permittee will be considered in compliance with this limitation when the survival of aquatic organisms in a 96-hour bioassay of undiluted effluent complies with the following:

i. Minimum for any one bioassay: 70 percent survival; and

ii. Median for any three or more consecutive bioassays: at least 90 percent survival.

Compliance with this effluent limitation shall be determined in accordance with section VII.I of this Order and section V.A of the MRP (Attachment E).

e. **Chronic Toxicity.** As measured at Monitoring Location EFF-003, there shall be no chronic toxicity in the effluent when discharging to the brackish marsh. Compliance with this narrative effluent limitation shall be determined in accordance with section VII.J of this Order and sections V.B and V.C of the MRP (Attachment E).

C. Effluent Limitations – Discharge Points 002 and 003 (After Completion of Phase Two of the Upgrade Project)

1. Final Effluent Limitations – Discharge Point 002

a. The discharge of treated wastewater shall maintain compliance with the following effluent limitations at Discharge Point 002, with compliance measured at Monitoring Location EFF-002, unless otherwise noted, as described in the MRP (Attachment E). Final effluent limitations for Discharge Point 002 will take effect once activation of the oxidation ditch has been completed, or on June 30, 2024, whichever comes first. Time Schedule Order No R1-2019-0011 has a compliance date for Phase Two of the Upgrade Project of June 30, 2024.

Table 7. Effluent Limitations – Discharge Point 002 (After Completion of Phase Two of the Upgrade Project)

Parameter	Units	Effluent Limitations ¹				
		Average Monthly	Average Weekly	Maximum Daily	Instantaneous Minimum	Instantaneous Maximum
Biochemical Oxygen Demand 5-day @ 20°C (BOD ₅)	mg/L	30	45	--	--	--
Total Suspended Solids (TSS)	mg/L	30	45	--	--	--
pH	standard units	--	--	--	6.0	8.5

Table Notes:
 1. See Definitions in Attachment A and Compliance Determination discussion in section VII of this Order.

b. **Percent Removal.** The average monthly percent removal of BOD₅ and TSS shall not be less than 85 percent. Percent removal shall be determined from the monthly average value of influent wastewater concentration in comparison to the monthly average value

of effluent concentration for the same constituent over the same time period as measured at Monitoring Locations INF-001 and EFF-002, respectively.

- c. **Disinfection.** Disinfected effluent discharged from the Facility through Discharge Point 002 to the Arcata Marsh Wildlife Sanctuary (AMWS) shall not contain fecal coliform bacteria exceeding the following concentrations, as measured at Monitoring Location EFF-002:
 - i. The median concentration shall not exceed an MPN of 14 per 100 mL using the bacteriological results of the last calendar month for which analyses have been completed; and
 - ii. The number of fecal coliform bacteria shall not exceed an MPN of 43 per 100 mL in more than 10% of samples in any calendar month.

2. Final Effluent Limitations – Discharge Point 003 (After Completion of Phase Two of the Upgrade Project)

- a. The discharge of treated wastewater shall maintain compliance with the following effluent limitations at Discharge Point 003, with compliance measured at Monitoring Location EFF-003 as described in the MRP (Attachment E). Time Schedule Order No R1-2019-0011 has a compliance date for Phase Two of the Upgrade Project of June 30, 2024.

Table 8. Effluent Limitations – Discharge Point 003

Parameter	Units	Effluent Limitations ¹				
		Average Monthly	Average Weekly	Maximum Daily	Instantaneous Minimum	Instantaneous Maximum
Copper, Total Recoverable	µg/L	3.3	--	5.3	--	--
Cyanide, Total (as CN)	µg/L	0.43	--	1.0	--	--
TCDD-Equivalents	µg/L	1.4 x 10 ⁻⁸	--	3.3 x 10 ⁻⁸	--	--
Ammonia Impact Ratio ³	Ratio	1.0 ²	--	1.0 ²	--	--
Settleable Solids	ml/L	0.1	--	0.2	--	--

Table Notes:

1. See Definitions in Attachment A and Compliance Determination discussion in section VII of this Order.
2. The Ammonia Impact Ratio (AIR) is calculated as the ratio of the ammonia concentration in the effluent and the applicable ammonia standard (AMEL and MDEL). Attachment H is a PDF example of the calculator that will be sent to the Permittee to determine compliance with the AMEL/MDEL AIR. For each of the applicable ammonia standards, Attachment G includes two tables that provide the variable AMEL and MDEL ammonia standards used in calculating the AIR. The AIR is the ammonia effluent limit and must be reported in the self-monitoring reports in addition to ammonia, pH and temperature values. Monitoring for ammonia, pH and temperature must be conducted concurrently in order for the AIR to be calculated properly. Compliance determination will be based on the receiving water data and ammonia effluent data taken on the day.
3. See sections VII.L and VII.M of this Order regarding compliance with each AIR effluent limitation.

- b. **Percent Removal.** The average monthly percent removal of BOD₅ and TSS shall not be less than 85 percent. Percent removal shall be determined from the monthly average value of influent wastewater concentration in comparison to the monthly average value

of effluent concentration for the same constituent over the same time period, as measured at Monitoring Locations INF-001 and EFF-003, respectively.

- c. **Acute Toxicity.** There shall be no acute toxicity in treated wastewater discharged to Humboldt Bay. The Permittee will be considered in compliance with this limitation when the survival of aquatic organisms in a 96-hour bioassay of undiluted effluent complies with the following:
 - i. Minimum for any one bioassay: 70 percent survival; and
 - ii. Median for any three or more consecutive bioassays: at least 90 percent survival.

Compliance with this effluent limitation shall be determined in accordance with section VII.I of this Order and section V.A of the MRP (Attachment E).

- d. **Chronic Toxicity.** As measured at Monitoring Location EFF-003, there shall be no chronic toxicity in the effluent when discharging to the brackish marsh. Compliance with this narrative effluent limitation shall be determined in accordance with section VII.J of this Order and sections V.B and V.C of the MRP (Attachment E).

3. Interim Effluent Limitations – Not Applicable

This Order does not establish interim effluent limitations or schedules for compliance with final limitations.

D. Discharge Specifications

1. Discharge Specifications – Discharge Point 002 (Prior to completion of Phase Two of the Upgrade Project)

- a. The Discharge of treated wastewater shall maintain compliance with the following final discharge specifications at Discharge Point 002, with compliance measured and Monitoring Location EFF-002, as described in the MRP (Attachment E). Discharge Specifications for Discharge Point 002 are in effect until activation of the oxidation ditch in Phase Two of the Proposed Treatment Upgrade or until June 30, 2024, whichever comes first.

Table 9. Discharge Specifications – Discharge Point 002 (Prior to completion of Phase Two of the Upgrade Project)

Parameter	Units	Effluent Limitations ¹				
		Average Monthly	Average Weekly	Maximum Daily	Instantaneous Minimum	Instantaneous Maximum
Biochemical Oxygen Demand 5-day @ 20°C (BOD ₅)	mg/L	38	57	--	--	--
Total Suspended Solids (TSS)	mg/L	32	48	--	--	--
pH	standard units	--	--	--	6.0	8.5
Chlorine, Total Residual ²	mg/L	0.01	--	0.02	--	--
Settleable Solids	ml/L	0.1	--	0.2	--	--

Parameter	Units	Effluent Limitations ¹				
		Average Monthly	Average Weekly	Maximum Daily	Instantaneous Minimum	Instantaneous Maximum
<p><u>Table Notes:</u></p> <p>1. See Definitions in Attachment A and Compliance Determination discussion in section VII of this Order.</p> <p>2. Limitations for chlorine residual apply at all times. However, monitoring for chlorine residual may be discontinued as specified in Table E-4, Footnote 7 of the MRP (Attachment E).</p>						

E. Land Discharge Specifications and Requirements – Not Applicable

This Order does not authorize discharges to land.

F. Water Recycling Specifications and Requirements – Not Applicable

This Order does not authorize discharges of recycled water.

G. Other Requirements

1. Disinfection Process Requirements for Ultraviolet Light (UV) Disinfection System¹

The Permittee shall operate the UV disinfection system to maintain compliance with disinfection effluent limitations specified in section IV.A.2.c of this Order. Specifically, the Permittee shall:

- a. Prior to initial discharge at Discharge Point 003, the Permittee shall submit, for Executive Officer approval, a copy of a letter from the UV supplier showing written acceptance of the UV system design specifications and capacity for the Facility.
- b. Prior to initial discharge at Discharge Point 003, the Permittee shall submit to the Executive Officer approval, an operations and maintenance plan detailing how compliance with the National Water Research Institute’s guidelines or the U.S. EPA UV Disinfection Guidance Manual will be assured at all times.
- c. Provide continuous, reliable monitoring of flow, UV transmittance (UVT), UV intensity, UV dose, and UV power at Monitoring Location INT-001. The Permittee must demonstrate compliance with the UV dose requirement.
- d. Operate the UV disinfection system to provide a minimum UV dose of 50 millijoules per square centimeter (mJ/cm²) at all times at Monitoring Location INT-001.
- e. Ensure that the UVT (at least 254 nanometers) in the wastewater does not fall below 35 percent of maximum at any time.
- f. Visually inspect the quartz sleeves and cleaning system components per the manufacturer’s operation manual for physical wear (scoring, solarization, seal leaks, etc.) and check the efficacy of the cleaning system.
- g. Wipe/clean the quartz sleeves at fixed intervals following the manufacturer’s procedures to ensure the minimum required UV dose delivery is consistently achieved. Cleaning intervals shall be increased as necessary to ensure compliance with permit requirements, such as UV dose and fecal coliform organism requirements.

¹ These Disinfection Requirements will take effect upon activation of Phase One of the Proposed Treatment Upgrade.

- h.** Operate the UV disinfection system in accordance with an approved operations and maintenance plan, which clearly specifies the operational limits and responses required for critical alarms. The Permittee shall maintain a copy of the approved operations plan at the treatment plant and make the plan readily available to properly trained operations personnel and regulatory agencies. The Permittee shall post a quick reference plant operations data sheet at the treatment plant. The data sheet shall include the following information:
 - i.** The alarm set points for high and low flow, UV dose and transmittance, UV lamp operation hours, and power.
 - ii.** The values of high and low flow, UV dose and transmittance, UV lamp operation hours, and power when flow must be diverted to waste.
 - iii.** The values of high daily and weekly median fecal coliform when an operational response must be taken.
 - iv.** The required frequency of calibration for all meters measuring flow, UVT, and power.
 - v.** The required frequency of mechanical cleaning/wiping and equipment inspection.
- i.** Replace lamps per the manufacturer's recommendation, or sooner, if there are indications the lamps are failing to provide adequate disinfection. The Permittee shall maintain lamp age and lamp replacement records for a time period consistent with the record retention requirements in the Standard Provisions (Attachment D, section IV).
- j.** Properly calibrate flow meters and UVT monitors to ensure proper disinfection.
- k.** Inspect the UVT meter and check against a reference bench-top unit weekly to document accuracy.
- l.** Recalibrate the on-line UVT analyzer by a procedure recommended by the manufacturer if the on-line analyzer UVT reading varies from the bench-top spectrophotometer UVT reading by 2 percent or more.
- m.** Operate the UV disinfection system with a built-in automatic reliability feature that must be triggered when the system is below the target UV dose. If the measured UV dose goes below the minimum UV dose, the UV reactor in question must alarm and startup the next available row of UV lamps or UV lamp bank.
- n.** Not allow equivalent or substitutions of equipment to occur without an adequate demonstration of equivalent disinfection performance to the satisfaction and approval of the Executive Officer.
- o.** Ensure that flow through the UV disinfection system not exceed the peak design flow of the system as a daily maximum.

V. RECEIVING WATER LIMITATIONS

A. Surface Water Limitations

Receiving water limitations are based on water quality objectives contained in the Basin Plan and are a required part of this Order. Receiving water conditions not in conformance with the

limitations are not necessarily a violation of this Order. Compliance with receiving water limitations shall be measured at monitoring locations described in the MRP (Attachment E). The Regional Water Board may require an investigation to determine cause and culpability prior to asserting that a violation has occurred.

Discharges from the Facility shall not cause the following in the receiving waters:

1. The discharge shall not cause the dissolved oxygen concentration of the receiving water to be depressed below 6.0 mg/L.

In those waterbodies for which the aquatic life-based DO requirements are unachievable due to natural conditions¹, site-specific background DO requirements can be applied² as water quality objectives by calculating the daily minimum DO necessary to maintain 85% DO saturation during the dry season and 90% DO saturation during the wet season under site salinity, site atmospheric pressure, and natural receiving water temperature³. In no event may controllable factors reduce the daily minimum DO below 6.0 mg/L.

For the protection of estuarine habitat (EST), the dissolved oxygen concentration of enclosed bays and estuaries shall not be depressed to levels adversely affecting beneficial uses as a result of controllable water quality factors.

2. The discharge shall not cause the pH of receiving waters to be depressed below natural background levels nor raised above 8.5. Within this range, the discharge shall not cause the pH of the receiving waters to be changed at any time more than 0.2 units from that which occurs naturally.
3. The discharge shall not cause the turbidity of receiving waters to be increased more than 20 percent above naturally occurring background levels.
4. The discharge shall not cause receiving waters to contain suspended material in concentrations that cause nuisance or adversely affect beneficial uses.
5. The discharge shall not cause receiving waters to contain floating materials, including solids, liquids, foams, and scum, in concentrations that cause nuisance or adversely affect beneficial uses.
6. The discharge shall not cause receiving waters to contain taste- or odor-producing substances in concentrations that impart undesirable tastes or odors to fish flesh or other edible products of aquatic origin, that cause nuisance, or that adversely affect beneficial uses.
7. The discharge shall not cause coloration of receiving waters that causes nuisance or adversely affects beneficial uses.

¹ Natural conditions are conditions or circumstances affecting the physical, chemical, or biological integrity of water that are not influenced by past or present anthropogenic activities.

² Upon approval from the Regional Water Board Executive Officer.

³ The method(s) used to estimate natural temperatures for a given waterbody or stream length must be approved by the Executive Officer and may include, as appropriate, comparison with reference streams, simple calculation, or computer models.

8. The discharge shall not contain substances in concentrations that result in deposition of material in receiving waters to the extent that such deposits cause nuisance or adversely affect beneficial uses.
9. The discharge shall not cause receiving waters to contain concentrations of biostimulatory substances that promote objectionable aquatic growth to the extent that such growth causes nuisance or adversely affects beneficial uses.
10. The discharge shall not cause receiving waters to contain toxic substances in concentrations that are toxic to, or that produce detrimental physiological responses in humans, plants, animals, or aquatic life. Compliance with this objective will be determined by use of indicator organisms, analyses of species diversity, population density, growth anomalies, bioassays of appropriate duration, or other appropriate methods, as specified by the Regional Water Board.
11. The discharge shall not cause a measurable temperature change in the receiving water at any time.
12. The discharge shall not cause an individual pesticide or combination of pesticides to be present in concentrations that adversely affect beneficial uses. The discharge shall not cause bioaccumulation of pesticide concentrations in bottom sediments or aquatic life.
13. The discharge shall not cause receiving waters to contain concentrations of pesticides in excess of Maximum Contaminant Levels (MCLs) established for these pollutants in title 22, division 4, chapter 15, articles 4 and 5.5 of the CCR.
14. The discharge shall not cause receiving waters to contain oils, greases, waxes, or other materials in concentrations that result in a visible film or coating on the surface of the water or on objects in the water, that cause nuisance, or that otherwise affect beneficial uses.
15. The discharge shall not cause a violation of any applicable water quality standard for receiving waters adopted by the Regional Water Board or the State Water Board, as required by the federal Clean Water Act and regulations adopted thereunder. If more stringent applicable water quality standards are promulgated or approved pursuant to section 303 of the Clean Water Act, or amendments thereto, the Regional Water Board will revise and modify this Order in accordance with such more stringent standards.
16. The discharge shall not cause concentrations of chemical constituents to occur in excess of MCLs and secondary MCLs (SMCLs) established for these pollutants in title 22, division 4, chapter 15, articles 4, section 64431, article 5.5, section 64444, and article 16, section 64449 of the CCR.
17. The discharge shall not cause receiving waters to contain radionuclides in concentrations which are deleterious to human, plant, animal or aquatic life, nor which result in the accumulation of radionuclides in the food web to an extent which presents a hazard to human, plant, animal or indigenous aquatic life, nor in excess of the MCLs and SMCLs established for these pollutants in title 22, division 4, chapter 15, article 5, sections 64442 and 64443 of the CCR.

B. Groundwater Limitations

1. The collection, treatment, storage, and disposal of wastewater shall not cause degradation of groundwater quality unless a technical evaluation is performed that demonstrates that any degradation that could reasonably be expected to occur, after implementation of all regulatory requirements (e.g., Basin Plan) and reasonable best management practices (BMPs), will not violate groundwater quality objectives or cause impacts to beneficial uses of groundwater.
2. The collection, treatment, storage, and disposal of wastewater shall not cause alterations of groundwater that contain chemical concentrations in excess of the MCLs and SMCLs established for these pollutants in title 22, division 4, chapter 15, article 4, sections 64435 (Tables 2 and 3) 64431, and article 5.5, section 64444, and article 16 section 64449 and the Basin Plan.
3. The collection, treatment, storage, and disposal of wastewater shall not cause groundwater to contain levels of radionuclides in concentrations that cause nuisance or adversely affect beneficial uses, nor in excess of the MCLs and SMCLs established in title 22, division 4, chapter 15, article 5, sections 64442 and 64443 of the CCR
4. The collection, treatment, storage, and disposal of wastewater shall not cause groundwater to contain taste- or odor-producing substances in concentrations that cause nuisance or adversely affect beneficial uses.
5. In groundwaters used for domestic or municipal supply (MUN), the collection, treatment, storage, and disposal of wastewater shall not cause the median of the most probable number of coliform organisms over any 7-day period to exceed 1.1 MPN/100 mL or 1 colony/100 mL.
6. Groundwaters shall not contain toxic substances in concentrations that are toxic to, or that produce detrimental physiological responses in humans, or that adversely affects beneficial uses. This limitation applies regardless of whether the toxicity is caused by a single substance or the synergistic effect of multiple substances.

VI. PROVISIONS

A. Standard Provisions

1. **Federal Standard Provisions.** The Permittee shall comply with all Standard Provisions included in Attachment D of this Order.
2. **Regional Water Board Standard Provisions.** The Permittee shall comply with the following Regional Water Board standard provisions. In the event that there is any conflict, duplication, or overlap between provisions specified by this Order, the more stringent provision shall apply:
 - a. Failure to comply with provisions or requirements of this Order, or violation of other applicable laws or regulations governing discharges from this Facility, may subject the Permittee to administrative or civil liabilities, criminal penalties, and/or other enforcement remedies to ensure compliance. Additionally, certain violations may subject the Permittee to civil or criminal enforcement from appropriate local, state, or federal law enforcement entities.

- b. In the event the Permittee does not comply or will be unable to comply for any reason, with any prohibition, final effluent limitation, other specification, receiving water limitation, or provision of this Order that may result in a significant threat to human health or the environment, such as inundation of treatment infrastructure, breach of pond containment, SSO, etc., that results in a discharge to a drainage channel or a surface water, the Permittee shall notify Regional Water Board staff within 24 hours of having knowledge of such noncompliance. Spill notification and reporting shall be conducted in accordance with section V.E of Attachment D and section X.E of the MRP.

B. Monitoring and Reporting Program (MRP) Requirements

The Permittee shall comply with the MRP, included as Attachment E to this Order, and future revisions thereto.

C. Special Provisions

1. Reopener Provisions

- a. **Standard Revisions.** If applicable water quality standards are promulgated or approved pursuant to section 303 of the CWA, or amendments thereto, the Regional Water Board may reopen this Order and make modifications in accordance with such revised standards.
- b. **Reasonable Potential.** This Order may be reopened for modification to include an effluent limitation if monitoring establishes that the discharge causes, or has the reasonable potential to cause or contribute to, an excursion above a water quality criterion or objective applicable to the receiving water.
- c. **Whole Effluent Toxicity (WET).** As a result of a Toxicity Reduction Evaluation (TRE), this Order may be reopened to include a numeric chronic toxicity limitation, a new acute toxicity limitation, and/or a limitation for a specific toxicant identified in the TRE. Additionally, if a numeric chronic toxicity water quality objective is adopted by the State Water Board, this Order may be reopened to include a numeric chronic toxicity effluent limitation based on that objective.
- d. **303(d)-Listed Pollutants.** If an applicable total maximum daily load (TMDL) (see Fact Sheet, section III.D) program is adopted, this Order may be reopened and effluent limitations for the pollutant(s) that are the subject of the TMDL may be modified or imposed to conform this Order to the TMDL requirements.
- e. **Water Effects Ratios (WERs) and Metal Translators.** A default WER of 1.0 has been used in this Order for calculating CTR criteria for applicable priority pollutant inorganic constituents, except for copper at Discharge Point 001. In addition, default dissolved-to-total metal translators have been used to convert water quality objectives from dissolved to total recoverable. If the Permittee performs studies to determine site-specific WERs and/or site-specific dissolved-to-total metal translators and submits a report that demonstrates that WER or translator studies were performed in accordance with U.S. EPA or other approved guidance, this Order may be reopened to modify the effluent limitations for the applicable constituents.
- f. **Nutrients.** This Order contains effluent limitations for ammonia and effluent monitoring requirements for nutrients (ammonia, nitrate, and phosphorus). If new

water quality objectives for nutrients are established, if monitoring data indicate the need for new or revised effluent limitations for any of these parameters, or if new or revised methods for compliance with effluent limitations for any of these parameters are developed, this Order may be reopened and modified to include new or modified effluent limitations or other requirements, as necessary.

- g. Ultraviolet Light (UV) Disinfection Operating Specifications¹.** The UV operating specifications in this Order are based on the Permittee's proposed design specifications for the UV disinfection system, which identify site-specific UV operating specifications that will achieve virus inactivation necessary to protect oyster growing areas within Humboldt Bay. If the Permittee conducts additional site-specific UV engineering studies that identify necessary revisions to the site-specific UV operating specifications necessary achieve the desired virus inactivation, this Order may be reopened to modify the UV operating specifications.

2. Special Studies, Technical Reports and Additional Monitoring Requirements

- a. Arcata Marsh Wildlife Sanctuary (AMWS) Evaluation.** The Permittee shall continue to implement the approved work plan for the ongoing evaluation of the beneficial uses of the AMWS identified by the Regional Water Board under section III of the Fact Sheet.

The Permittee shall provide a summary of the findings from the evaluation with the Report of Waste Discharge (ROWD), due one year prior to the expiration date of this Order. The findings from the ongoing evaluation will be used for adaptive management to ensure the AMWS retains maximum treatment function while protecting beneficial uses.

- b. Disaster Preparedness Assessment Report and Action Plan.** Natural disasters, extreme weather events, sea level rise, and shifting precipitation patterns, some of which are projected to intensify due to climate change, have significant implications for wastewater treatment and operations. Some natural disasters are expected to become more frequent and extreme according to the current science on climate change. In order to ensure that Facility operations are not disrupted, compliance with conditions of this Order are achieved, and receiving waters are not adversely impacted by permitted and unpermitted discharges, the Permittee shall submit a Disaster Preparedness Assessment Report and Action Plan to the Regional Water Board by **June 1, 2022**, for Executive Officer review and approval.

The Permittee shall: (1) conduct an assessment of the wastewater treatment facility, operations, collection, and discharge systems to determine areas of short- and long-term vulnerabilities related to natural disasters and extreme weather, including sea level rise and other conditions projected by climate change science, if applicable; the assessment shall consider, as applicable, impacts to plant operations due to changing influent and receiving water quality, rising sea level, storm surges, fires, floods, earthquakes, tsunamis, back-to-back severe storms, and other extreme conditions that pose a risk to plant operations and water quality; (2) identify control measures needed to protect, improve, and maintain wastewater infrastructure, waste discharge compliance, and receiving water quality in the event of a natural disaster or, if

¹ These Disinfection Requirements will take effect upon activation of Phase I of the Proposed Treatment Upgrade.

applicable, under conditions resulting from climate change; (3) develop a schedule to implement necessary control measures. Control measures shall include, but are not limited to, emergency procedures, contingency plans, alarm/notification systems, training, backup power and equipment, and the need for planned mitigations to ameliorate potential risks associated with extreme weather events and changing conditions resulting from climate change; and (4) implement the necessary control measures per the approved schedule of implementation.

c. Source Control and Pretreatment Studies.

The Permittee shall review the existing sections in the pretreatment program and submit, for Executive Officer review and approval, a written description of the pretreatment program. The written description of the pretreatment program shall be submitted by December 31, 2023 and consist of the following sections:

i. Organizational and Multi-jurisdiction Implementation

This section shall describe the overall program structure as well as contain descriptions of the Facility, collection system and the service area including political boundaries.

ii. Legal Authority

This section shall contain a revised Sewer Use Ordinance (SUO) and all necessary multi-jurisdictional agreements to allow for the implementation of the pretreatment program. The SUO shall be submitted as a final draft ready for adoption and implementation pending approval of the local limits, described below, by the Regional Water Board Executive Officer.

iii. Local Limits¹

This section shall describe the technical basis for the local limits and shall provide a work plan for conducting a Local Limits Study in accordance with U.S. EPA's July 2004 Local Limits Development Guidance (EPA 833-R-04-002A. and shall include a schedule for conducting the Local Limits Study and for public hearings and outreach.

The Permittee shall conduct a Local Limits Study to determine the pollutants of concern, collect and analyze data, calculate maximum allowable headworks loadings (MAHLs) for each pollutant of concern at the Facility and the maximum pollutant levels protective of the collection system, the method for allocating allowable loadings to users, and designate and implement technically-based local limits, where necessary, for industrial users discharging to the Permittee's collection system. The Local Limits can be numerical concentrations, loading limits, prohibitions or control strategies.

iv. Identification of Non-domestic Users

¹ A new Local Limits Study will be performed once Phase Two of the Proposed Upgrade Project is completed. The 2019 TSO establishes a compliance schedule for completion of the Phase Two of the Proposed Upgrade Project.

This section shall contain the procedures to be used in the initial Industrial Waste Survey (IWS) as well as the procedures to be used for on-going updates. This section shall also include the current inventory of industrial users, by non-domestic sewer connection, and of the zero-discharging categorical industrial users who comply with their Federal standards by not discharging process wastewater.

The inventory must indicate the following for each industrial user and zero-discharging categorical industrial users:

- (a) Whether it qualifies as a significant industrial user;
- (b) The average and peak flow rates;
- (c) The SIC code;
- (d) The pretreatment-in-place, and;
- (e) The local permit status

v. Permits and Fact Sheets

This section shall describe the permitting procedures and include a fact sheet and final draft permit for each significant industrial user to be issued upon approval of the local limits and revised SUO by the Regional Water Board Executive Officer. The fact sheets must indicate the following for each significant industrial user and zero-discharging categorical industrial user:

- (a) The industry name, owner or plant manager;
- (b) The permit expiration date (not to exceed five years in duration);
- (c) A description of the facility including the products made or services provided, building names, the process in each building and when current operations began;
- (d) The identification of each sewer connection;
- (e) A description of the contributing waste streams that comprise each identified non-domestic discharge to the sewers;
- (f) The pretreatment-in-place for each identified non-domestic discharge to the sewers;
- (g) The classification by Federal point source category and the reasons justifying classification;
- (h) The applicable Federal categorical pretreatment standards, supporting production data (if necessary), and the compliance sampling point(s) where the standards apply;
- (i) The pollutants of concern and the compliance sampling point(s) where the local limits apply;
- (j) A site map indicating the locations of all compliance sampling point(s), sewer connections, and sewer laterals;

- (k) The sampling frequency by regulated pollutant for each compliance sampling point, and the supporting statistical rationale, to ensure that the sampling is representative of the wastewater discharge variability over the reporting period;
- (l) The sampling protocol by regulated pollutant for each compliance sampling point to ensure that the samples collected to determine compliance with Federal standards are representative of the sampling day's discharge.

vi. Compliance Monitoring

This section shall describe the industrial user self-monitoring program and the Permittees oversight monitoring program. The compliance monitoring program shall ensure that all sampling is representative over the reporting period and that each sample collected to determine compliance with Federal standards is representative of the sampling day's discharge. The compliance monitoring program must also set analytical detection limits to allow the determination of non-compliance.

vii. Enforcement

This section shall establish the enforcement response plan (ERP) to be used to address, at a minimum, each of the following types of violations:

- (a) Isolated and chronic violations of permit effluent limitations;
- (b) Violations of permit effluent limitations that result in any adverse impacts upon the Facility such as pass-through, interference, sludge contamination, sewer line degradation, explosive or inflammability risks, or worker health and safety risks;
- (c) Failure to self-monitor or report;
- (d) The bypassing of pretreatment necessary to comply with Federal categorical pretreatment standards;
- (e) The bypassing of compliance sampling or the tampering with sampling equipment, and;
- (f) Willful or negligent violations.

viii. Resources

This section shall demonstrate that adequate budget, staffing and equipment is allocated to provide for the needs of the pretreatment program to ensure effective implementation.

ix. Public Participation and Confidentiality

This section shall describe the administrative procedures required under 40 CFR 403.8(f)(1)(vii) and 403.8(f)(2)(viii).

3. Best Management Practices and Pollution Prevention

a. Pollutant Minimization Program (PMP)

- i. The Permittee shall, as required by the Executive Officer, develop and conduct a PMP as further described below when there is evidence (e.g., sample results from analytical methods more sensitive than those methods required by this Order, presence of WET, health advisories for fish consumption, results of benthic or aquatic organism tissue sampling) that a CTR priority pollutant is present in the effluent above an effluent limitation and either:
 - (a) The concentration of the pollutant is reported as “Detected, but Not Quantified” (DNQ) and the effluent limitation is less than the reporting limit (RL);
 - (b) A sample result is reported as non-detect (ND) and the effluent limitation is less than the method detection limit (MDL), using definitions described in Attachment A and reporting protocols described in MRP section X.B.5.
- ii. The PMP shall include, but not be limited to, the following actions and submittals acceptable to the Regional Water Board:
 - (a) An annual review and semi-annual monitoring of potential sources of the reportable CTR priority pollutant(s), which may include fish tissue monitoring and other bio-uptake sampling;
 - (b) Quarterly monitoring for the reportable CTR priority pollutant(s) in the influent to the wastewater treatment system;
 - (c) Submittal of a control strategy designed to proceed toward the goal of maintaining concentrations of the reportable CTR priority pollutant(s) in the effluent at or below the effluent limitation;
 - (d) Implementation of appropriate cost-effective control measures for the reportable CTR priority pollutant(s), consistent with the control strategy; and
 - (e) An annual status report that shall be submitted as part of the Annual Facility Report due **March 1st** to the Regional Water Board and shall include:
 - (1) All PMP monitoring results for the previous year;
 - (2) A list of potential sources of the reportable pollutant(s);
 - (3) A summary of all actions undertaken pursuant to the control strategy; and
 - (4) A description of actions to be taken in the following year.

4. Construction, Operation and Maintenance Specifications

- a. This Order (Attachment D, Standard Provision I.D) requires that the Permittee at all times properly operate and maintain all facilities and systems of treatment and control (and related appurtenances) that are installed or used by the Permittee to achieve

compliance with this Order. Proper operation and maintenance includes adequate laboratory quality control and appropriate quality assurance procedures.

- b.** The Permittee shall maintain an updated Operation and Maintenance (O&M) Manual for the operational components of the Facility. The Permittee shall update the O&M Manual, as necessary, to conform to changes in operation and maintenance of the Facility. The Permittee shall operate and maintain the Facility in accordance with the most recently updated O&M Manual. The O&M Manual shall be readily available to operating personnel on-site and for review by state or federal inspectors. The O&M Manual shall include the following.
 - i.** Description of the Facility's organizational structure showing the number of employees, duties, and qualifications, and plant attendance schedules (daily, weekends and holidays, part-time, etc.). The description should include documentation that the personnel are knowledgeable and qualified to operate the Facility so as to achieve the required level of treatment at all times.
 - ii.** Detailed description of safe and effective operation and maintenance of treatment processes, process control instrumentation and equipment.
 - iii.** Description of laboratory and quality assurance procedures.
 - iv.** Process and equipment inspection and maintenance schedules.
 - v.** Description of safeguards to assure that, should there be reduction, loss, or failure of electric power, the Permittee will be able to comply with requirements of this Order.
 - vi.** Description of preventive (fail-safe) and contingency (response and cleanup) plans for controlling accidental discharges, and for minimizing the effect of such events. These plans shall identify the possible sources (such as loading and storage areas, power outage, waste treatment unit failure, process equipment failure, tank and piping failure) of accidental discharges, untreated or partially treated waste bypass, and polluted drainage.

5. Special Provisions for Municipal Facilities (POTWs Only)

a. Wastewater Collection Systems

i. Statewide General WDRs for Sanitary Sewer Systems

The Permittee has coverage under, and is separately subject to, the requirements of State Water Board Order No. 2006-0003-DWQ, Statewide General WDRs for Sanitary Sewer Systems, as amended by Order No. WQ 2013-0058-EXEC. As such, the Permittee provides notification and reporting of SSOs in accordance with the requirements of Order Nos. 2006-0003-DWQ and WQ 2013-0058-EXEC and any revisions thereto for operation of its wastewater collection system.

b. Pretreatment of Industrial Waste

- i.** The Permittee shall be responsible for the performance of all pretreatment requirements contained in 40 C.F.R. part 403 and shall be subject to enforcement actions, penalties, fines, and other remedies by the U.S. EPA or other appropriate

parties as provided in the CWA, as amended (33 U.S.C. 1351 et seq.). The Permittee shall implement and enforce its approved Facility Pretreatment Program. The Permittee's approved Facility Pretreatment Program is hereby made an enforceable condition of this Order. U.S. EPA may initiate enforcement action against an industrial user for noncompliance with applicable standards and requirements as provided in the CWA.

- ii.** The Permittee shall enforce the requirements promulgated under section 307(b), 307(c), 307(d), and 402(d) of the CWA. The Permittee shall cause industrial users subject to Federal Categorical Standards to achieve compliance no later than the date specified in those requirements or, in the case of a new industrial user, upon commencement of the discharge.
- iii.** The Permittee shall perform the pretreatment functions as required in 40 C.F.R. part 403, including, but not limited to:
 - (a)** Implement the necessary legal authorities as provided in 40 C.F.R. section 403.8(f)(1);
 - (b)** Enforce the pretreatment requirements under 40 C.F.R. sections 403.5 and 403.6;
 - (c)** Implement the programmatic functions as provided in 40 C.F.R. section 403.8(f)(2); and
 - (d)** Provide the requisite funding and personnel to implement the pretreatment program as provided in 40 C.F.R. section 403.8(f)(3).
- iv.** The Permittee shall implement, as more completely set forth in 40 C.F.R. section 403.5, the necessary legal authorities, programs, and controls to ensure that the following incompatible wastes are not introduced to the treatment system:
 - (a)** Wastes that create a fire or explosion hazard in the treatment works;
 - (b)** Wastes that will cause corrosive structural damage to treatment works, but in no case wastes with a pH lower than 5.0, unless the works is specially designed to accommodate such wastes;
 - (c)** Solid or viscous wastes in amounts that cause obstruction to flow in sewers, or that cause other interference with proper operation of treatment works;
 - (d)** Any waste, including oxygen demanding pollutants (BOD₅, etc.), released in such volume or strength as to cause inhibition or disruption in the treatment works, and subsequent treatment process upset and loss of treatment efficiency;
 - (e)** Heat in amounts that inhibit or disrupt biological activity in the treatment works, or that raise influent temperatures above 40°C (104°F);
 - (f)** Petroleum oil, non-biodegradable cutting oil, or products of mineral oil origin in amounts that will cause interference or pass through;

- (g) Pollutants which result in the presence of toxic gases, vapors, or fumes within the treatment works in a quantity that may cause acute worker health and safety problems; and
 - (h) Any trucked or hauled pollutants, except at points predesignated by the Permittee, and consisting of waste that can be adequately treated at the Facility.
- v. The Permittee shall implement, as more completely set forth in 40 C.F.R. section 403.5, the legal authorities, programs, and controls necessary to ensure that indirect discharges do not introduce pollutants into the sewerage system that, either alone or in conjunction with a discharge or discharges from other sources:
 - (a) Flow through the system to the receiving water in quantities or concentrations that cause a violation of this Order, or
 - (b) Inhibit or disrupt treatment processes, treatment system operations, or sludge processes, use, or disposal and either cause a violation of this Order or prevent sludge use or disposal in accordance with this Order.

c. Sludge Disposal and Handling Requirements

- i. Sludge, as used in this Order, means the solid, semisolid, and liquid residues removed during primary, secondary, or advanced wastewater treatment processes. Solid waste refers to grit and screenings generated during preliminary treatment. Biosolids refers to sludge that has been treated, tested, and demonstrated to be capable of being beneficially and legally used pursuant to federal and state regulations as a soil amendment for agriculture, silviculture, horticulture, and land reclamation activities.
- ii. All collected sludges and other solid waste removed from liquid wastes shall be removed from screens, sumps, ponds, and tanks as needed to ensure optimal plant operation and disposed of in accordance with applicable federal and state regulations.
- iii. The use and disposal of biosolids shall comply with all of the land application and disposal requirements in 40 C.F.R. part 503, which are enforceable by the U.S. EPA, not the Regional Water Board. If during the life of this Order, the state accepts primacy for implementation of 40 C.F.R. part 503, the Regional Water Board may also initiate enforcement where appropriate.
- iv. Sludge or biosolids that are disposed of in a municipal solid waste landfill or used as daily landfill cover shall meet the applicable requirements of 40 C.F.R. part 258. In the annual self-monitoring report, the Permittee shall report the amount of sludge placed in a landfill and the landfill(s) which received the sludge or biosolids.
- v. The Permittee shall take all reasonable steps to prevent and minimize any sludge use or disposal in violation of this Order that may adversely affect human health or the environment.

- vi. Solids and sludge treatment, storage, and disposal or reuse shall not create a nuisance, such as objectionable odors or flies, and shall not result in groundwater contamination.
- vii. Solids and sludge treatment and storage sites shall have facilities adequate to divert surface water runoff from adjacent areas, to protect the boundaries of the site from erosion, and to prevent drainage from the treatment and storage site. Adequate protection is defined as protection from a design storm with a 100-year recurrence interval and 24-hour duration.
- viii. The discharge of sewage sludge and solids shall not cause waste material to be in a position where it is, or can be, conveyed from the treatment and storage sites and deposited in the waters of the state.
- ix. For the land application of biosolids as a soil amendment, the Permittee shall submit a ROWD or the Permittee may dispose of biosolids at another appropriately permitted facility.
- x. New sludge treatment and storage facilities must comply with the requirements of the Water Code and title 27 of the CCR for the protection of water quality.

d. Operator Certification

Supervisors and operators of municipal wastewater treatment facilities shall possess a certificate of appropriate grade in accordance with title 23, CCR, section 3680. The State Water Board may accept experience in lieu of qualification training. In lieu of a properly certified wastewater treatment facility operator, the State Water Board may approve use of a water treatment facility operator of appropriate grade certified by DDW where water recycling is involved.

e. Adequate Capacity

If the Facility will reach capacity within 4 years, the Permittee shall notify the Regional Water Board. A copy of such notification shall be sent to appropriate local elected officials, local permitting agencies, and the press. Factors to be evaluated in assessing reserve capacity shall include, at a minimum, (1) comparison of the wet weather design flow with the highest daily flow, and (2) comparison of the average dry weather design flow with the lowest 30-day flow. The Permittee shall demonstrate that adequate steps are being taken to address the capacity problem. The Permittee shall submit a technical report to the Regional Water Board showing how flow volumes will be prevented from exceeding capacity, or how capacity will be increased, **within 120 days after providing notification to the Regional Water Board**, or within 120 days after receipt of Regional Water Board notification that the Facility will reach capacity within 4 years. The time for filing the required technical report may be extended by the Regional Water Board. An extension of 30 days may be granted by the Executive Officer, and longer extensions may be granted by the Regional Water Board itself. [CCR title 23, section 2232].

6. Other Special Provisions

a. Storm Water

BMPs to control the run-on of storm water to the Facility site shall be maintained and upgraded as necessary. The Permittee shall describe the effectiveness of these storm water BMPs, as well as activities to maintain and upgrade these BMPs during the previous year, in its annual report to the Regional Water Board.

7. Compliance Schedules – Not Applicable

This Order does not establish interim effluent limitations or schedules of compliance for final numeric effluent limitations.

VII. COMPLIANCE DETERMINATION

Compliance with the prohibitions and effluent limitations contained in sections III and IV of this Order will be determined as specified below.

A. General

Compliance with effluent limitations for CTR priority pollutants, when effluent limitations have been established, shall be determined using sample reporting protocols defined in the MRP and Attachment A of this Order. For purposes of reporting and administrative enforcement by the Regional and State Water Boards, the Permittee shall be deemed out of compliance with effluent limitations if the concentration of pollutant in the monitoring sample is greater than the effluent limitation and greater than or equal to the reported minimum level (ML).

B. Multiple Sample Data

When determining compliance with an average monthly effluent limitation (AMEL) for CTR priority pollutants, and more than one sample result is available, the Permittee shall compute the arithmetic mean unless the data set contains one or more reported determinations of DNQ or ND. In those cases, the Permittee shall compute the median in place of the arithmetic mean in accordance with the following procedure.

1. The data set shall be ranked from low to high, ranking the reported ND determinations lowest, DNQ determinations next, followed by quantified values (if any). The order of the individual ND or DNQ determinations is unimportant.
2. The median value of the data set shall be determined. If the data set has an odd number of data points, then the median is the middle value. If the data set has an even number of data points, then the median is the average of the two middle values unless one or both of the points are ND or DNQ, in which case the median value shall be the lower of the two data points where DNQ is lower than a value and ND is lower than DNQ and a value of zero shall be used for the ND or DNQ value in the median calculation for compliance purposes only. Using a value of zero for DNQ or ND samples does not apply when performing reasonable potential or antidegradation analysis.

C. Average Monthly Effluent Limitation (AMEL)

If the average (or when applicable, the median determined by subsection B, above, for multiple sample data) of daily discharges over a calendar month exceeds the AMEL for a given parameter, this will represent a single violation, though the Permittee will be considered out of compliance

for each day of that month for that parameter (e.g., resulting in 31 days of noncompliance in a 31-day month). If only a single sample is taken during the calendar month and the analytical result for that sample exceeds the AMEL, the Permittee will be considered out of compliance for that calendar month. The Permittee will only be considered out of compliance for days when the discharge occurs. If there are ND or DNQ results for a specific constituent in a calendar month, the Permittee shall calculate the median of all sample results within that month for compliance determination with the AMEL as described in section VII.B, above.

D. Average Weekly Effluent Limitation (AWEL)

If the average (or when applicable, the median determined by subsection B, above, for multiple sample data) of daily discharges over a calendar week exceeds the AWEL for a given parameter, this will represent a single violation, though the Permittee will be considered out of compliance for each day of that week for that parameter, resulting in 7 days of non-compliance. If only a single sample is taken during the calendar week and the analytical result for that sample exceeds the AWEL, the Permittee will be considered out of compliance for that calendar week. The Permittee will only be considered out of compliance for days when the discharge occurs. If there are ND or DNQ results for a specific constituent in a calendar week, the Permittee shall calculate the median of all sample results within that week for compliance determination with the AWEL as described in section VII.B, above.

E. Maximum Daily Effluent Limitation (MDEL)

If a daily discharge (or when applicable, the median determined by subsection B, above, for multiple sample data of a daily discharge) exceeds the MDEL for a given parameter, the Permittee will be considered out of compliance for that parameter for that 1 day only within the reporting period.

F. Instantaneous Minimum Effluent Limitation

If the analytical result of a single grab sample is lower than the instantaneous minimum effluent limitation for a parameter, the Permittee will be considered out of compliance for that parameter for that single sample. Noncompliance for each sample will be considered separately (e.g., the results of two grab samples taken within a calendar day that both are lower than the instantaneous minimum effluent limitation would result in two instances of noncompliance with the instantaneous minimum effluent limitation).

If the Permittee monitors pH continuously, pursuant to 40 C.F.R. section 401.17, the Permittee shall be in compliance with the pH limitation specified herein provided that both of the following conditions are satisfied: (1) the total sum of time during which the pH values are outside the required range of pH values shall not exceed 7 hours and 26 minutes in any calendar month; and (2) no individual excursion from the range of pH values shall exceed 60 minutes.

G. Instantaneous Maximum Effluent Limitation

If the analytical result of a single grab sample is higher than the instantaneous maximum effluent limitation for a parameter, the Permittee will be considered out of compliance for that parameter for that single sample. Noncompliance for each sample will be considered separately (e.g., the results of two grab samples taken within a calendar day that both exceed the instantaneous maximum effluent limitation would result in two instances of noncompliance with the instantaneous maximum effluent limitation).

If the Permittee monitors pH continuously, pursuant to 40 C.F.R. section 401.17, the Permittee shall be in compliance with the pH limitation specified herein provided that both of the following conditions are satisfied: (1) the total sum of time during which the pH values are outside the required range of pH values shall not exceed 7 hours and 26 minutes in any calendar month; and (2) no individual excursion from the range of pH values shall exceed 60 minutes.

H. Bacteriological Limitations (Fecal Coliform)

1. **Median.** The median is the central tendency concentration of the pollutant. The data set shall be ranked from low to high, ranking the ND concentrations lowest, followed by quantified values. The median value is determined based on the number of data points in the set. If the data set has an odd number of data points, then the median is the middle value. If the data set has an even number of data points, the median is the average of the two middle values, unless one or both points are ND or DNQ, in which case the median value shall be the lower of the two middle data points. DNQ is lower than a detected value, and ND is lower than DNQ.

I. Acute Toxicity Limitations

Compliance with the three-sample median acute toxicity effluent limitation shall be determined when there is a discharge, by calculating the median percent survival of the three most recent consecutive samples meeting all test acceptability criteria collected from Monitoring Location EFF-001 for discharges at Discharge Point 001 and Monitoring Location EFF-003 for discharges at Discharge Point 003.

Compliance with the accelerated monitoring and TRE provisions shall constitute compliance with the acute toxicity requirements, as specified in the MRP (Attachment E, sections V.A and V.C).

J. Chronic Toxicity

Compliance with the accelerated monitoring and TRE provisions specified in the MRP (Attachment E, sections V.B.8 and V.C) shall constitute compliance with the narrative chronic toxicity requirement specified as Effluent Limitation IV.A.3.c. The narrative chronic toxicity limitation is exceeded when a chronic toxicity test, analyzed using the TST approach, results in "Fail" and the "Percent Effect" is ≥ 0.50 . The relative "Percent (%) Effect" at the discharge Instream Waste Concentration (IWC) is defined and reported as: $((\text{Mean control response} - \text{Mean discharge IWC response}) \div \text{Mean control response}) \times 100$. The chronic toxicity IWC for a chronic toxicity test is 100 percent effluent¹. In addition, compliance with the accelerated monitoring and TRE provisions identified in the MRP (Attachment E, sections V.B and V.C) is further required.

K. Average Dry Weather Flow

Compliance with the average dry weather flow prohibition in section III.H of this Order will be determined once each calendar year by evaluating all flow data collected at Monitoring Location INF-001 in a calendar year. The flow through the Facility, measured daily and averaged monthly, must be 2.3 mgd or less for the month with the lowest average monthly flow.

¹ The chronic toxicity test shall be conducted using a series of five dilutions and a control. The series shall consist of the following dilutions: 12.5, 25, 50, 75, and 100 percent. Compliance determination will be based on the IWC (100 percent effluent) and a control as further described in section IV.C.5.c of the Fact Sheet (Attachment F).

L. Ammonia Impact Ratio AMEL

Compliance with the ammonia impact ratio average monthly effluent limitation in sections IV.A.1 and IV.A.3 of this Order will be determined based on the monthly average of the receiving water pH, temperature and salinity samples. If more than one monthly ammonia sample is taken in the month, the average of the ammonia samples will be used in conjunction with the average of the receiving water samples. If the AIR is greater than 1.0 then the Permittee is considered out of compliance with the AIR AMEL.

M. Ammonia Impact Ratio MDEL

Compliance with the ammonia impact ratio maximum daily effluent limitation in sections IV.A.1 and IV.A.3 of this Order will be determined based on the receiving water pH, temperature and salinity samples taken on the same day as the ammonia sample in the effluent. If the AIR is greater than 1.0 then the Permittee is considered out of compliance with the AIR MDEL.

ATTACHMENT A – DEFINITIONS

Arithmetic Mean (μ)

Also called the average is the sum of measured values divided by the number of samples. For ambient water concentrations, the arithmetic mean is calculated as follows:

Arithmetic mean = $\mu = \Sigma x / n$ where: Σx is the sum of the measured ambient water concentrations, and n is the number of samples.

Average Monthly Effluent Limitation (AMEL)

The highest allowable average of daily discharges over a calendar month, calculated as the sum of all daily discharges measured during a calendar month divided by the number of daily discharges measured during that month.

Average Weekly Effluent Limitation (AWEL)

The highest allowable average of daily discharges over a calendar week (Sunday through Saturday), calculated as the sum of all daily discharges measured during a calendar week divided by the number of daily discharges measured during that week.

Bioaccumulative Pollutants

Substances taken up by an organism from its surrounding medium through gill membranes, epithelial tissue, or from food and subsequently concentrated and retained in the body of the organism.

Carcinogenic Pollutants

Substances that are known to cause cancer in living organisms.

Coefficient of Variation (CV)

A measure of the data variability and is calculated as the estimated standard deviation divided by the arithmetic mean of the observed values.

Daily Discharge

Daily Discharge is defined as either: (1) the total mass of the constituent discharged over the calendar day (12:00 am through 11:59 pm) or any 24-hour period that reasonably represents a calendar day for purposes of sampling (as specified in the permit), for a constituent with limitations expressed in units of mass or; (2) the unweighted arithmetic mean measurement of the constituent over the day for a constituent with limitations expressed in other units of measurement (e.g., concentration).

The daily discharge may be determined by the analytical results of a composite sample taken over the course of one day (a calendar day or other 24-hour period defined as a day) or by the arithmetic mean of analytical results from one or more grab samples taken over the course of the day.

For composite sampling, if 1 day is defined as a 24-hour period other than a calendar day, the analytical result for the 24-hour period will be considered as the result for the calendar day in which the 24-hour period ends.

Detected, but Not Quantified (DNQ)

Sample results that are less than the reported Minimum Level, but greater than or equal to the laboratory's MDL. Sample results reported as DNQ are estimated concentrations.

Dilution Credit

The amount of dilution granted to a discharge in the calculation of a water quality-based effluent limitation, based on the allowance of a specified mixing zone. It is calculated from the dilution ratio or determined through conducting a mixing zone study or modeling of the discharge and receiving water.

Effective Concentration (EC)

A point estimate of the toxicant concentration that would cause an adverse effect on a quantal, “all or nothing,” response (such as death, immobilization, or serious incapacitation) in a given percent of the test organisms. If the effect is death or immobility, the term lethal concentration (LC) may be used. EC values may be calculated using point estimation techniques such as probit, logit, and Spearman-Kärber. EC25 is the concentration of toxicant (in percent effluent) that causes a response in 25 percent of the test organisms.

Effluent Concentration Allowance (ECA)

A value derived from the water quality criterion/objective, dilution credit, and ambient background concentration that is used, in conjunction with the coefficient of variation for the effluent monitoring data, to calculate a long-term average (LTA) discharge concentration. The ECA has the same meaning as wasteload allocation (WLA) as used in U.S. EPA guidance (Technical Support Document For Water Quality-based Toxics Control, March 1991, second printing, EPA/505/2-90-001).

Enclosed Bays

Indentations along the coast that enclose an area of oceanic water within distinct headlands or harbor works. Enclosed bays include all bays where the narrowest distance between headlands or outermost harbor works is less than 75 percent of the greatest dimension of the enclosed portion of the bay. This definition includes but is not limited to: Humboldt Bay, Bodega Harbor, Tomales Bay, Drakes Estero, San Francisco Bay, Morro Bay, Los Angeles Harbor, Upper and Lower Newport Bay, Mission Bay, and San Diego Bay.

Estimated Chemical Concentrations

The estimated chemical concentration that results from the confirmed detection of the substance by the analytical method below the ML value.

Estuaries and Coastal Lagoons are waters at the mouths of streams that serve as mixing zones for fresh and ocean waters during a major portion of the year. Mouths of streams that are temporarily separated from the ocean by sandbars shall be considered as estuaries. Estuarine waters will generally be considered to extend from a bay or the open ocean to the upstream limit of tidal action but may be considered to extend seaward if significant mixing of fresh and saltwater occurs in the open coastal waters. The waters described by this definition include but are not limited to the Sacramento-San Joaquin Delta as defined by section 12220 of the California Water Code, Suisun Bay, Carquinez Strait downstream to Carquinez Bridge, and appropriate areas of the Smith, Klamath, Mad, Eel, Noyo, Russian, San Diego, and Otay Rivers. Estuaries do not include inland surface waters or ocean waters.

Field Measurement

Water quality field measurements are determinations of physical or chemical properties that must be measured onsite, as close as possible in time and space to the medium being sampled. Onsite measurements are necessary to preserve sample integrity and ensure data accuracy.

Inhibition Concentration

The IC25 is typically calculated as a percentage of effluent. It is the level at which the organisms exhibit 25 percent reduction in biological measurement such as reproduction or growth. It is calculated statistically and used in chronic toxicity testing.

Inland Surface Waters

All surface waters of the State that do not include the ocean, enclosed bays, or estuaries.

Instantaneous Maximum Effluent Limitation

The highest allowable value for any single grab sample or aliquot (i.e., each grab sample or aliquot is independently compared to the instantaneous maximum limitation).

Instantaneous Minimum Effluent Limitation

The lowest allowable value for any single grab sample or aliquot (i.e., each grab sample or aliquot is independently compared to the instantaneous minimum limitation).

Lowest Observed Effect Concentration (LOEC)

The lowest concentration of an effluent or toxicant that results in adverse effects on the test organism (i.e., where the values for the observed endpoints are statistically different from the control).

Maximum Daily Effluent Limitation (MDEL)

The highest allowable daily discharge of a pollutant, over a calendar day (or 24-hour period). For pollutants with limitations expressed in units of mass, the daily discharge is calculated as the total mass of the pollutant discharged over the day. For pollutants with limitations expressed in other units of measurement, the daily discharge is calculated as the arithmetic mean measurement of the pollutant over the day.

Median

The middle measurement in a set of data. The median of a set of data is found by first arranging the measurements in order of magnitude (either increasing or decreasing order). If the number of measurements (n) is odd, then the median = $X_{(n+1)/2}$. If n is even, then the median = $(X_{n/2} + X_{(n/2)+1})/2$ (i.e., the midpoint between the $n/2$ and $n/2+1$).

Method Detection Limit (MDL)

The minimum concentration of a substance that can be measured and reported with 99 percent confidence that the analyte concentration is distinguishable from method blank results, as defined in 40 C.F.R. part 136, revised as of August 28, 2017.

Minimum Level (ML)

The concentration at which the entire analytical system must give a recognizable signal and acceptable calibration point. The ML is the concentration in a sample that is equivalent to the concentration of the lowest calibration standard analyzed by a specific analytical procedure, assuming that all the method specified sample weights, volumes, and processing steps have been followed.

Mixing Zone

A limited volume of receiving water that is allocated for mixing with a wastewater discharge where water quality criteria can be exceeded without causing adverse effects to the overall water body.

Not Detected (ND)

Those sample results less than the laboratory's MDL

No Observed Effect Concentration (NOEC)

The highest tested concentration of an effluent or a test sample at which the effect is no different from the control effect, according to the statistical test used (see LOEC). The NOEC is usually the highest tested concentration of an effluent or toxicant that causes no observable effects on the aquatic test organisms (i.e., the highest concentration of toxicity at which the values for the observed responses do not statistically differ from the controls). It is determined using hypothesis testing.

Ocean Waters

The territorial marine waters of the state as defined by California law to the extent these waters are outside of enclosed bays, estuaries, and coastal lagoons. If a discharge outside the territorial waters of the state could affect the quality of the waters of the state, the discharge may be regulated to assure no violation of the Ocean Plan will occur in ocean waters.

Persistent Pollutants

Substances for which degradation or decomposition in the environment is nonexistent or very slow.

Pollutant Minimization Program (PMP)

PMP means waste minimization and pollution prevention actions that include, but are not limited to, product substitution, waste stream recycling, alternative waste management methods, and education of the public and businesses. The goal of the PMP shall be to reduce all potential sources of a CTR priority pollutant(s) through pollutant minimization (control) strategies, including pollution prevention measures as appropriate, to maintain the effluent concentration at or below the water quality-based effluent limitation. Pollution prevention measures may be particularly appropriate for persistent bioaccumulative CTR priority pollutants where there is evidence that beneficial uses are being impacted. The Regional Water Board may consider cost effectiveness when establishing the requirements of a PMP. The completion and implementation of a Pollution Prevention Plan, if required pursuant to Water Code section 13263.3(d), shall be considered to fulfill the PMP requirements.

Pollution Prevention

Any action that causes a net reduction in the use or generation of a hazardous substance or other pollutant that is discharged into water and includes, but is not limited to, input change, operational improvement, production process change, and product reformulation (as defined in Water Code section 13263.3). Pollution prevention does not include actions that merely shift a pollutant in wastewater from one environmental medium to another environmental medium, unless clear environmental benefits of such an approach are identified to the satisfaction of the State or Regional Water Board.

Publicly Owned Treatment Works (POTW)

A treatment works as defined in section 212 of the Clean Water Act (CWA), which is owned by a State or municipality as defined by section 502(4) of the CWA. [Section 502(4) of the CWA defines a municipality as a city, town, borough, county, parish, district, association, or other public body created by or pursuant to State law and having jurisdiction over disposal of sewage, industrial wastes, or other wastes). This definition includes any devices and systems used in the storage, treatment, recycling, and reclamation of municipal sewage or industrial wastes of a liquid nature. It also includes sewers, pipes and other conveyances only if they convey wastewater to a POTW Treatment Plant. The term also means the municipality as defined in section 502(4) of the CWA, which has jurisdiction over the Indirect Discharges to and the discharges from such a treatment works.

Reporting Level (RL)

The RL is the ML (and its associated analytical method) chosen by the Permittee for reporting and compliance determination from the MLs included in this Order, including an additional factor if applicable as discussed herein. The MLs included in this Order correspond to approved analytical methods for

reporting a sample result that are selected by the Regional Water Board either from Appendix 4 of the SIP in accordance with section 2.4.2 of the SIP or established in accordance with section 2.4.3 of the SIP. The ML is based on the proper application of method-based analytical procedures for sample preparation and the absence of any matrix interferences. Other factors may be applied to the ML depending on the specific sample preparation steps employed. For example, the treatment typically applied in cases where there are matrix-effects is to dilute the sample or sample aliquot by a factor of ten. In such cases, this additional factor must be applied to the ML in the computation of the RL.

Septage

Defined as the liquid or solid material removed from a septic tank, cesspool, portable toilet, type III marine sanitation device, recreational vehicle’s sanitation tank, or similar storage or treatment works that receives domestic waste.

Shellfish

Organisms identified by the California Department of Health Services as shellfish for public health purposes (i.e., mussels, clams, and oysters).

Significant Difference

Defined as a statistically significant difference in the means of two distributions of sampling results at the 95 percent confidence level.

Source of Drinking Water

Any water designated as municipal or domestic supply (MUN) in a Regional Water Board Basin Plan.

Standard Deviation (σ)

A measure of variability that is calculated as follows:

$$\sigma = (\sum[(x - \mu)^2]/(n - 1))^{0.5}$$

where:

x is the observed value;

μ is the arithmetic mean of the observed values; and

n is the number of samples.

TCDD Equivalents

The sum of the concentrations of chlorinated dibenzodioxins (2,3,7,8-CDDs) and chlorinated dibenzofurans (2,3,7,8-CDFs) multiplied by their respective toxicity factors, as shown in the table below.

Isomer Group	Toxicity Equivalence Factor
2,3,7,8-tetra CDD	1.0
2,3,7,8-penta CDD	0.5
2,3,7,8-hexa CDDs	0.1
2,3,7,8-hepta CDD	0.01
octa CDD	0.001
2,3,7,8 tetra CDF	0.1
1,2,3,7,8 penta CDF	0.05
2,3,4,7,8 penta CDF	0.5
2,3,7,8 hexa CDFs	0.1
2,3,7,8 hepta CDFs	0.01
octa CDF	0.001

Toxicity Reduction Evaluation (TRE)

A study conducted in a stepwise process designed to identify the causative agents of effluent or ambient toxicity, isolate the sources of toxicity, evaluate the effectiveness of toxicity control options, and then confirm the reduction in toxicity. The first steps of the TRE consist of the collection of data relevant to the toxicity, including additional toxicity testing, and an evaluation of facility operations and maintenance practices, and best management practices. A Toxicity Identification Evaluation (TIE) may be required as part of the TRE, if appropriate. (A TIE is a set of procedures to identify the specific chemical(s) responsible for toxicity. These procedures are performed in three phases (characterization, identification, and confirmation) using aquatic organism toxicity tests.)

Test of Significant Toxicity (TST)

The statistical approach described in National Pollutant Discharge Elimination System Test of Significant Toxicity Implementation Document (EPA 833-R10-003, 2010). TST was developed by the U.S. Environmental Protection Agency (EPA) for analyzing WET and ambient toxicity data. Using the TST approach, the sample is declared toxic if there is greater than or equal to a 25% effect in chronic tests, or if there is greater than or equal to a 20% effect in acute tests at the permitted instream waste concentration (IWC) (referred to as the toxic regulatory management decision (RMD)). The sample is declared non-toxic if there is less than or equal to a 10% effect at the IWC in acute or chronic tests (referred to as the non-toxic RMD).

ATTACHMENT B - LOCATION MAP

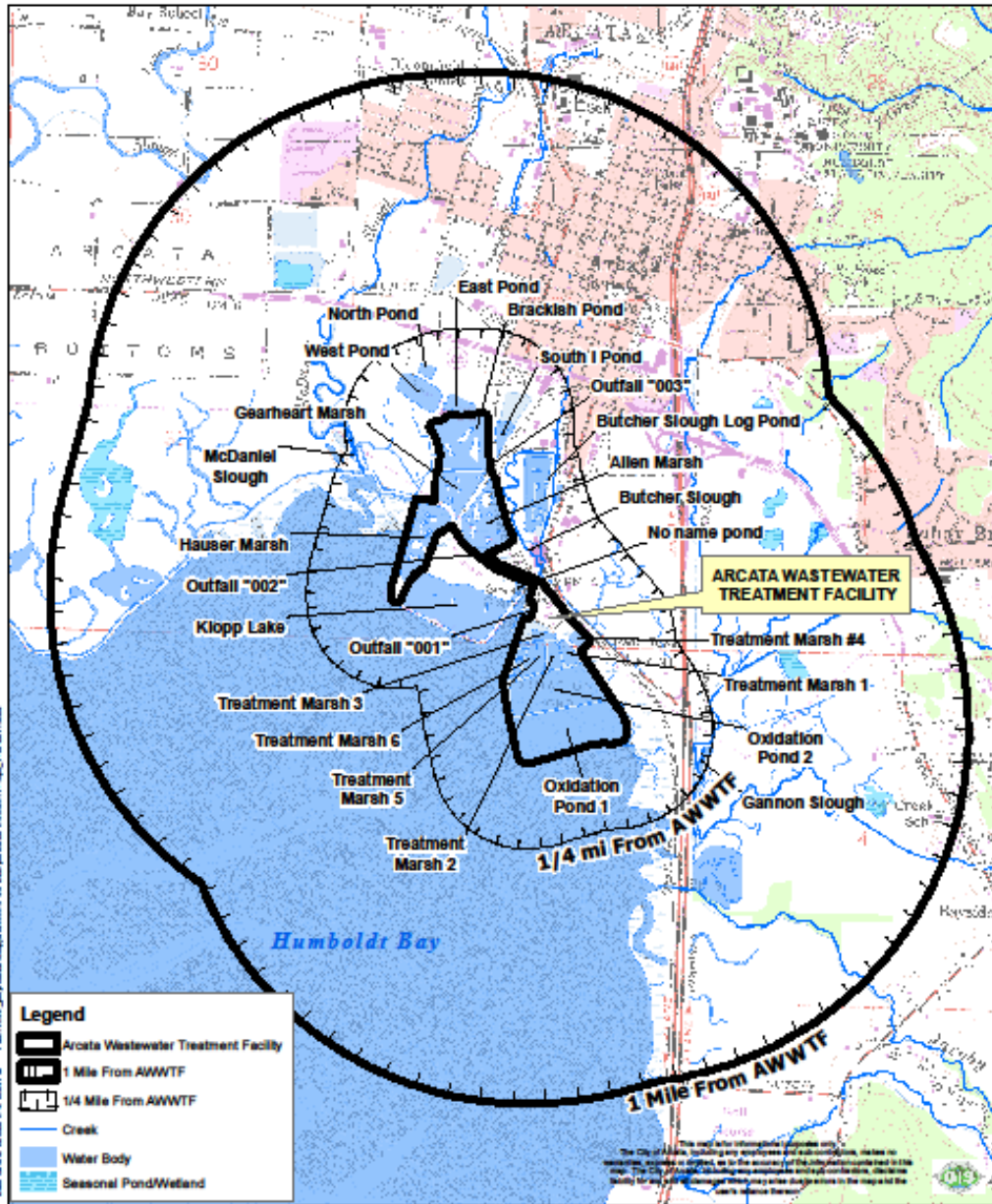

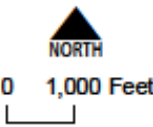
 <p>City of Arcata Environmental Services</p>	<h2>Arcata Wastewater Treatment Facility Topographical Map</h2> <p>U.S.G.S. 7.5 Minute Topographic Map: Arcata South Quadrangle Section 32 of T.6.N., R.1.E. of H.B. & M.</p>	 <p>NORTH 0 1,000 Feet</p>
--	---	---



Current Operations Arcata Wastewater Treatment Facility

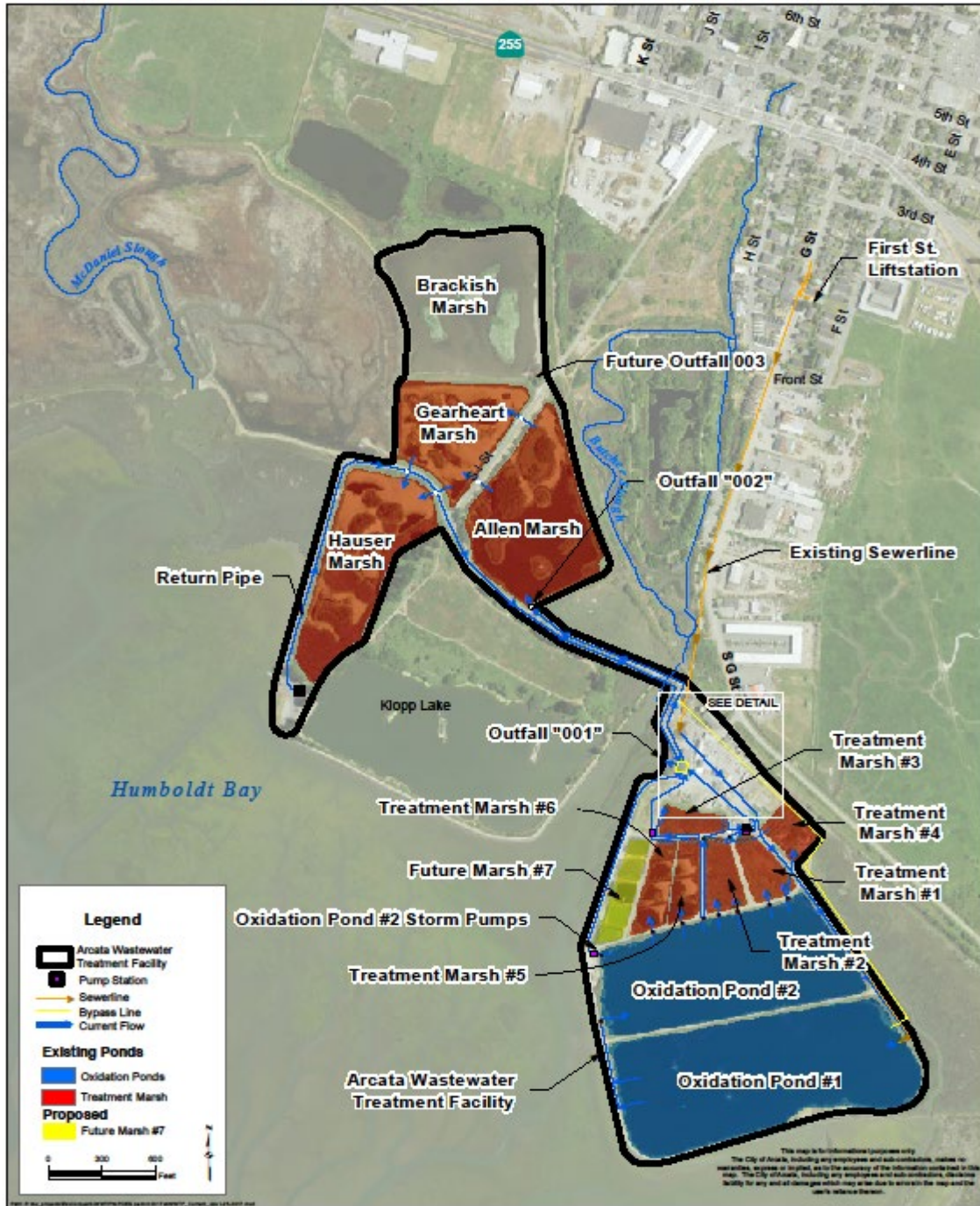

ATTACHMENT C – FLOW SCHEMATIC
Figure C-1. Existing Wastewater Flow¹ Schematic

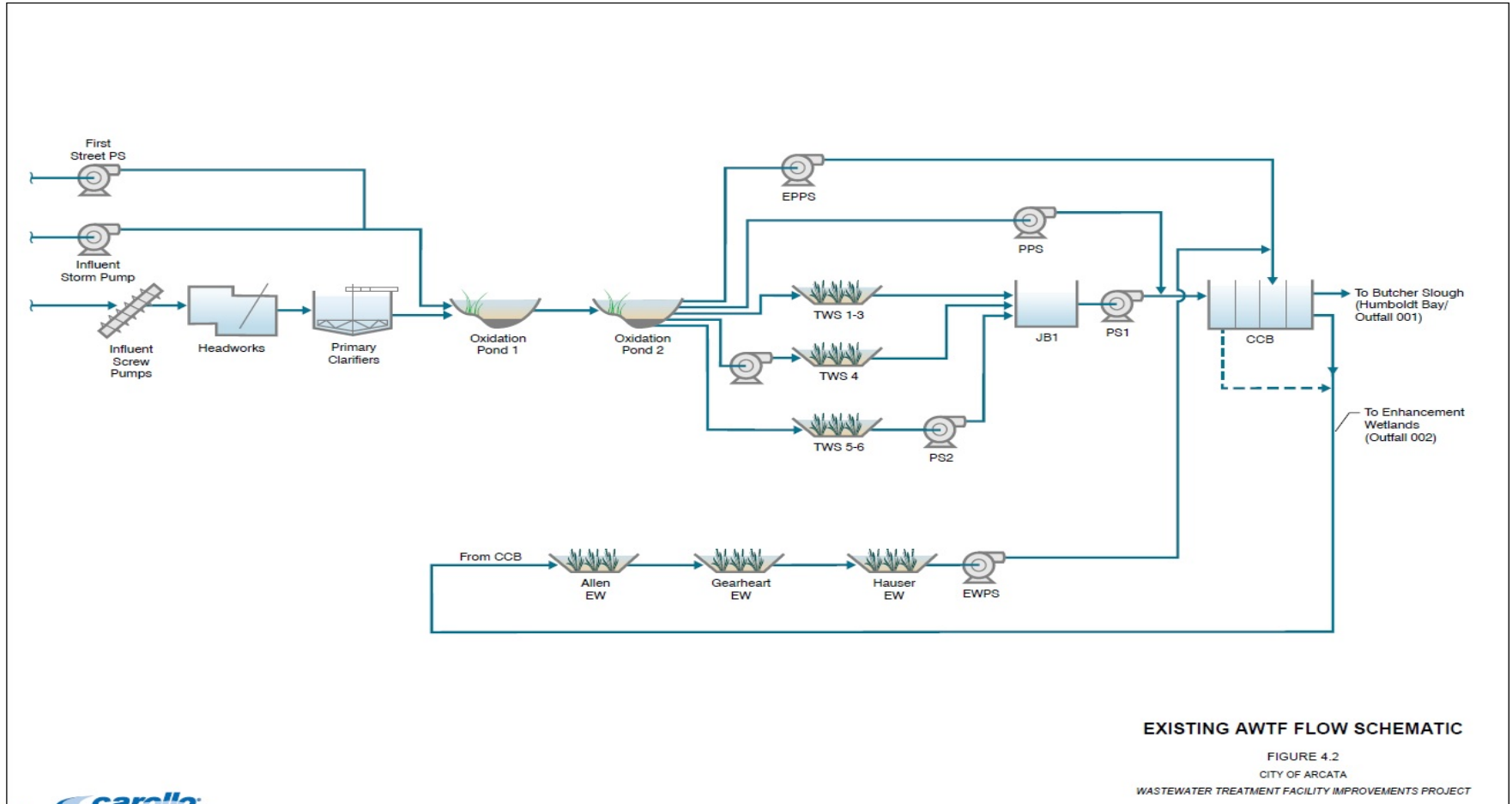

¹ Under the existing flow configuration, a portion of the treated effluent is sent to the enhancement marshes for enhanced treatment while the remainder is discharged to Humboldt Bay via Outfall-001. Average flow through Allen, Gearheart and Hauser Enhancement Wetlands from August 2012 through September 2018 was 1.14 mgd.

Figure C-2. Proposed Treatment Upgrade Flow Schematic

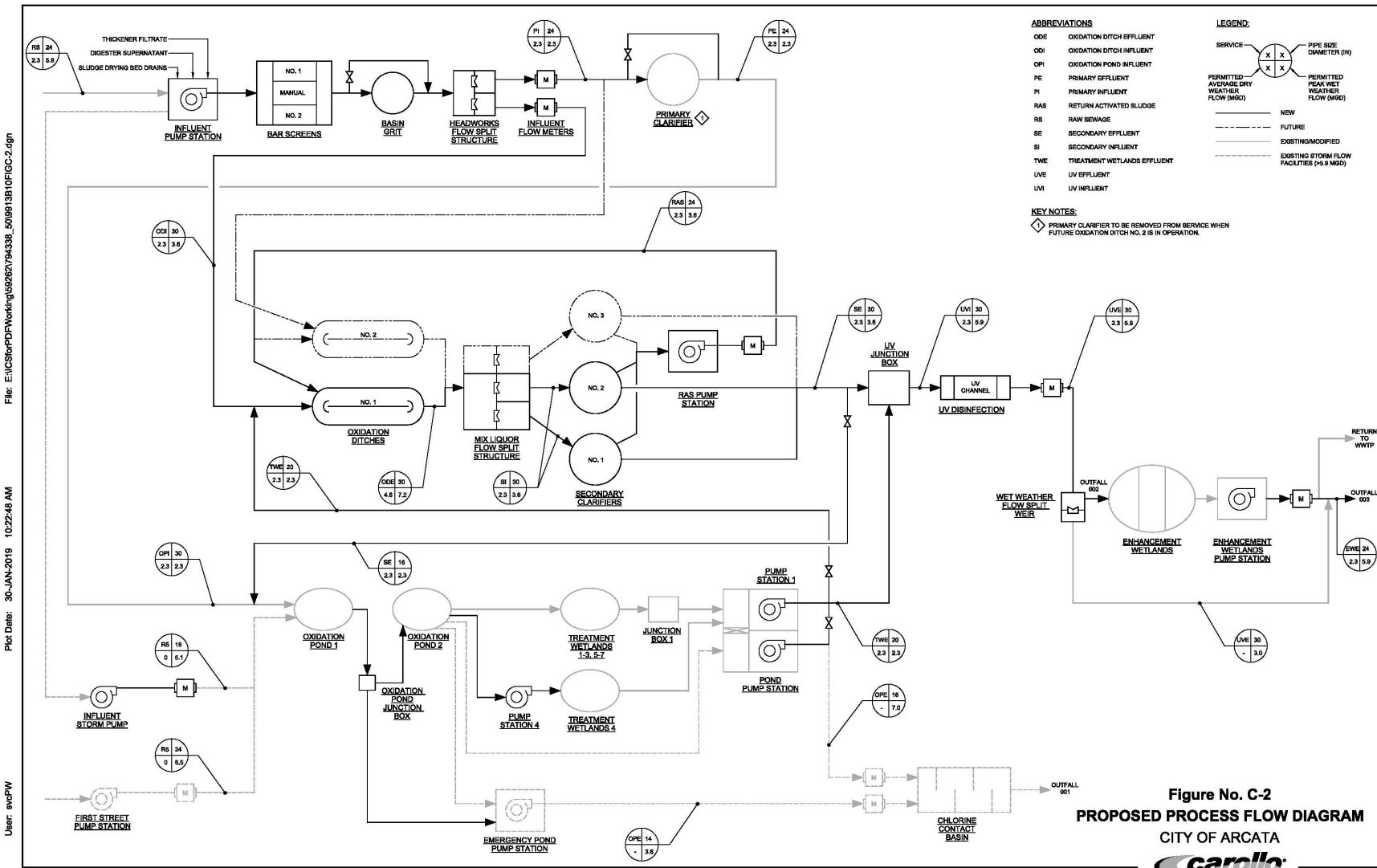

File: E:\HCS\pfd\Working\59262\794338_5\N0913810\FIG-C-2.dgn

Plot Date: 30-JAN-2019 10:22:48 AM

User: svcPW

ATTACHMENT D – STANDARD PROVISIONS

I. STANDARD PROVISIONS – PERMIT COMPLIANCE

A. Duty to Comply

1. The Permittee must comply with all of the conditions of this Order. Any noncompliance constitutes a violation of the Clean Water Act (CWA) and the California Water Code and is grounds for enforcement action, for permit termination, revocation and reissuance, or modification; or denial of a permit renewal application. (40 C.F.R. § 122.41(a); Wat. Code, §§ 13261, 13263, 13265, 13268, 13000, 130001, 13304, 13350, 13385)
2. The Permittee shall comply with effluent standards or prohibitions established under section 307(a) of the CWA for toxic pollutants and with standards for sewage sludge use or disposal established under section 405(d) of the CWA within the time provided in the regulations that establish these standards or prohibitions, even if this Order has not yet been modified to incorporate the requirement. (40 C.F.R. § 122.41(a)(1))

B. Need to Halt or Reduce Activity Not a Defense

It shall not be a defense for a Permittee in an enforcement action that it would have been necessary to halt or reduce the permitted activity in order to maintain compliance with the conditions of this Order. (40 C.F.R. § 122.41(c))

C. Duty to Mitigate

The Permittee shall take all reasonable steps to minimize or prevent any discharge or sludge use or disposal in violation of this Order that has a reasonable likelihood of adversely affecting human health or the environment. (40 C.F.R. § 122.41(d))

D. Proper Operation and Maintenance

The Permittee shall at all times properly operate and maintain all facilities and systems of treatment and control (and related appurtenances) which are installed or used by the Permittee to achieve compliance with the conditions of this Order. Proper operation and maintenance also includes adequate laboratory controls and appropriate quality assurance procedures. This provision requires the operation of backup or auxiliary facilities or similar systems that are installed by a Permittee only when necessary to achieve compliance with the conditions of this Order. (40 C.F.R. § 122.41(e))

E. Property Rights

1. This Order does not convey any property rights of any sort or any exclusive privileges. (40 C.F.R. § 122.41(g))
2. The issuance of this Order does not authorize any injury to persons or property or invasion of other private rights, or any infringement of state or local law or regulations. (40 C.F.R. § 122.5(c))

F. Inspection and Entry

The Permittee shall allow the Regional Water Board, State Water Board, U.S. EPA, and/or their authorized representatives (including an authorized contractor acting as their representative), upon the presentation of credentials and other documents, as may be required by law, to (33 U.S.C. § 1318(a)(4)(b); 40 C.F.R. § 122.41(i); Wat. Code, §§ 13267, 13383):

1. Enter upon the Permittee's premises where a regulated facility or activity is located or conducted, or where records are kept under the conditions of this Order (33 U.S.C. § 1318(a)(4)(b)(i); 40 C.F.R. § 122.41(i)(1); Wat. Code, §§ 13267, 13383);
2. Have access to and copy, at reasonable times, any records that must be kept under the conditions of this Order (33 U.S.C. § 1318(a)(4)(b)(ii); 40 C.F.R. § 122.41(i)(2); Wat. Code, §§ 13267, 13383);
3. Inspect and photograph, at reasonable times, any facilities, equipment (including monitoring and control equipment), practices, or operations regulated or required under this Order (33 U.S.C. § 1318(a)(4)(b)(ii); 40 C.F.R. § 122.41(i)(3); Wat. Code, §§ 13267, 13383); and
4. Sample or monitor, at reasonable times, for the purposes of assuring Order compliance or as otherwise authorized by the CWA or the Water Code, any substances or parameters at any location. (33 U.S.C. § 1318(a)(4)(b); 40 C.F.R. § 122.41(i)(4); Wat. Code, §§ 13267, 13383)

G. Bypass

1. Definitions

- a. "Bypass" means the intentional diversion of waste streams from any portion of a treatment facility. (40 C.F.R. § 122.41(m)(1)(i))
- b. "Severe property damage" means substantial physical damage to property, damage to the treatment facilities, which causes them to become inoperable, or substantial and permanent loss of natural resources that can reasonably be expected to occur in the absence of a bypass. Severe property damage does not mean economic loss caused by delays in production. (40 C.F.R. § 122.41(m)(1)(ii))

2. **Bypass not exceeding limitations.** The Permittee may allow any bypass to occur which does not cause exceedances of effluent limitations, but only if it is for essential maintenance to assure efficient operation. These bypasses are not subject to the provisions listed in Standard Provisions – Permit Compliance I.G.3, I.G.4, and I.G.5 below. (40 C.F.R. § 122.41(m)(2).)

3. **Prohibition of bypass.** Bypass is prohibited, and the Regional Water Board may take enforcement action against a Permittee for bypass, unless (40 C.F.R. § 122.41(m)(4)(i)):
 - a. Bypass was unavoidable to prevent loss of life, personal injury, or severe property damage (40 C.F.R. § 122.41(m)(4)(i)(A));
 - b. There were no feasible alternatives to the bypass, such as the use of auxiliary treatment facilities, retention of untreated wastes, or maintenance during normal periods of equipment downtime. This condition is not satisfied if adequate back-up equipment should have been installed in the exercise of reasonable engineering judgment to prevent a bypass that occurred during normal periods of equipment downtime or preventive maintenance (40 C.F.R. § 122.41(m)(4)(i)(B)); and
 - c. The Permittee submitted notice to the Regional Water Board as required under Standard Provisions – Permit Compliance I.G.5 below. (40 C.F.R. § 122.41(m)(4)(i)(C))

4. **Burden of Proof.** In any enforcement proceeding, the permittee seeking to establish the bypass defense has the burden of proof.
5. The Regional Water Board may approve an anticipated bypass, after considering its adverse effects, if the Regional Water Board determines that it will meet the three conditions listed in Standard Provisions – Permit Compliance I.G.3 above. (40 C.F.R. § 122.41(m)(4)(ii))

6. Notice

- a. **Anticipated bypass.** If the Permittee knows in advance of the need for a bypass, it shall submit a prior notice, if possible, at least 10 days before the date of the bypass. (40 C.F.R. § 122.41(m)(3)(i))
- b. **Unanticipated bypass.** The Permittee shall submit notice of an unanticipated bypass as required in Standard Provisions - Reporting V.E below (24-hour notice). (40 C.F.R. § 122.41(m)(3)(ii))

H. Upset

Upset means an exceptional incident in which there is unintentional and temporary noncompliance with technology-based permit effluent limitations because of factors beyond the reasonable control of the Permittee. An upset does not include noncompliance to the extent caused by operational error, improperly designed treatment facilities, inadequate treatment facilities, lack of preventive maintenance, or careless or improper operation.

(40 C.F.R. § 122.41(n)(1))

- 1. **Effect of an upset.** An upset constitutes an affirmative defense to an action brought for noncompliance with such technology-based permit effluent limitations if the requirements of Standard Provisions – Permit Compliance I.H.2 below are met. No determination made during administrative review of claims that noncompliance was caused by upset, and before an action for noncompliance, is final administrative action subject to judicial review. (40 C.F.R. § 122.41(n)(2))
- 2. **Conditions necessary for a demonstration of upset.** A Permittee who wishes to establish the affirmative defense of upset shall demonstrate, through properly signed, contemporaneous operating logs or other relevant evidence that (40 C.F.R. § 122.41(n)(3)):
 - a. An upset occurred and that the Permittee can identify the cause(s) of the upset (40 C.F.R. § 122.41(n)(3)(i));
 - b. The Facility was, at the time, being properly operated (40 C.F.R. § 122.41(n)(3)(ii));
 - c. The Permittee submitted notice of the upset as required in Standard Provisions – Reporting V.E.2.b below (24-hour notice) (40 C.F.R. § 122.41(n)(3)(iii)); and
 - d. The Permittee complied with any remedial measures required under Standard Provisions – Permit Compliance I.C above. (40 C.F.R. § 122.41(n)(3)(iv))
- 3. **Burden of Proof.** In any enforcement proceeding, the Permittee seeking to establish the occurrence of an upset has the burden of proof. (40 C.F.R. § 122.41(n)(4))

II. STANDARD PROVISIONS – PERMIT ACTION

A. General

This Order may be modified, revoked and reissued, or terminated for cause. The filing of a request by the Permittee for modification, revocation and reissuance, or termination, or a notification of planned changes or anticipated noncompliance does not stay any Order condition. (40 C.F.R. § 122.41(f))

B. Duty to Reapply

If the Permittee wishes to continue an activity regulated by this Order after the expiration date of this Order, the Permittee must apply for and obtain a new permit. (40 C.F.R. § 122.41(b))

C. Transfers

This Order is not transferable to any person except after notice to the Regional Water Board. The Regional Water Board may require modification or revocation and reissuance of the Order to

change the name of the Permittee and incorporate such other requirements as may be necessary under the CWA and the Water Code. (40 C.F.R. § 122.41(l)(3); § 122.61)

III. STANDARD PROVISIONS – MONITORING

- A.** Samples and measurements taken for the purpose of monitoring shall be representative of the monitored activity. (40 C.F.R. § 122.41(j)(1))
- B.** Monitoring must be conducted according to test procedures under 40 C.F.R. part 136 for the analyses of pollutants unless another method is required under 40 C.F.R. chapter 1, subchapters N or O. Monitoring must be conducted according to sufficiently sensitive test procedures (i.e., methods) approved under 40 C.F.R. part 136 for the analysis of pollutants or pollutant parameters or required under 40 C.F.R. chapter 1, subchapter N or O. For the purposes of this paragraph, a method is “sufficiently sensitive” when:
 - 1.** The method minimum level (ML) is at or below the level of the effluent limitation established in the permit for the measured pollutant or pollutant parameter, and, either the method ML is at or below the level of the applicable water quality criterion for the measured pollutant or pollutant parameter or the method ML is above the applicable water quality criterion, but the amount of the pollutant or pollutant parameter in a facility’s discharge is high enough that the method detects and quantifies the level of the pollutant or pollutant parameter in the discharge; or
 - 2.** The method has the lowest ML of the analytical methods approved under 40 C.F.R. part 136 or required under 40 C.F.R. chapter 1, subchapter N or O for the measured pollutant or pollutant parameter.

In the case of pollutants for which there are no approved methods under 40 C.F.R. part 136 or otherwise required under 40 C.F.R. chapter 1, subchapters N or O, monitoring must be conducted according to a test procedure specified in this Order for such pollutants. (40 C.F.R. § 122.41(j)(4); § 122.44(i)(1)(iv))

In the case of sludge use or disposal approved under 40 C.F.R. part 136, monitoring must be conducted according to test procedures in part 503 unless otherwise specified in 40 C.F.R. or other test procedures have been specified in this Order.

IV. STANDARD PROVISIONS – RECORDS

- A.** Except for records of monitoring information required by this Order related to the Permittee's sewage sludge use and disposal activities, which shall be retained for a period of at least five years (or longer as required by 40 C.F.R. part 503), the Permittee shall retain records of all monitoring information, including all calibration and maintenance records and all original strip chart recordings for continuous monitoring instrumentation, copies of all reports required by this Order, and records of all data used to complete the application for this Order, for a period of at least three (3) years from the date of the sample, measurement, report, or application. This period may be extended by request of the Regional Water Board Executive Officer at any time. (40 C.F.R. § 122.41(j)(2))
- B. Records of monitoring information shall include:**
 - 1.** The date, exact place, and time of sampling or measurements (40 C.F.R. § 122.41(j)(3)(i));
 - 2.** The individual(s) who performed the sampling or measurements (40 C.F.R. § 122.41(j)(3)(ii));
 - 3.** The date(s) analyses were performed (40 C.F.R. § 122.41(j)(3)(iii));
 - 4.** The individual(s) who performed the analyses (40 C.F.R. § 122.41(j)(3)(iv));

5. The analytical techniques or methods used (40 C.F.R. § 122.41(j)(3)(v)); and
6. The results of such analyses. (40 C.F.R. § 122.41(j)(3)(vi))

C. Claims of confidentiality for the following information will be denied (40 C.F.R. § 122.7(b)):

1. The name and address of any permit applicant or Permittee (40 C.F.R. § 122.7(b)(1)); and
2. Permit applications and attachments, permits and effluent data. (40 C.F.R. § 122.7(b)(2))

V. STANDARD PROVISIONS – REPORTING

A. Duty to Provide Information

The Permittee shall furnish to the Regional Water Board, State Water Board, or U.S. EPA within a reasonable time, any information which the Regional Water Board, State Water Board, or U.S. EPA may request to determine whether cause exists for modifying, revoking and reissuing, or terminating this Order or to determine compliance with this Order. Upon request, the Permittee shall also furnish to the Regional Water Board, State Water Board, or U.S. EPA copies of records required to be kept by this Order. (40 C.F.R. § 122.41(h); Wat. Code, § 13267)

B. Signatory and Certification Requirements

1. All applications, reports, or information submitted to the Regional Water Board, State Water Board, and/or U.S. EPA shall be signed and certified in accordance with Standard Provisions – Reporting V.B.2, V.B.3, V.B.4, and V.B.5 below. (40 C.F.R. § 122.41(k))
2. All permit applications shall be signed by either a principal executive officer or ranking elected official. For purposes of this provision, a principal executive officer of a federal agency includes: (i) the chief executive officer of the agency, or (ii) a senior executive officer having responsibility for the overall operations of a principal geographic unit of the agency (e.g., Regional Administrators of U.S. EPA). (40 C.F.R. § 122.22(a)(3))
3. All reports required by this Order and other information requested by the Regional Water Board, State Water Board, or U.S. EPA shall be signed by a person described in Standard Provisions – Reporting V.B.2 above, or by a duly authorized representative of that person. A person is a duly authorized representative only if:
 - a. The authorization is made in writing by a person described in Standard Provisions – Reporting V.B.2 above (40 C.F.R. § 122.22(b)(1));
 - b. The authorization specifies either an individual or a position having responsibility for the overall operation of the regulated facility or activity such as the position of plant manager, operator of a well or a well field, superintendent, position of equivalent responsibility, or an individual or position having overall responsibility for environmental matters for the company. (A duly authorized representative may thus be either a named individual or any individual occupying a named position.) (40 C.F.R. § 122.22(b)(2)); and
 - c. The written authorization is submitted to the Regional Water Board and State Water Board. (40 C.F.R. § 122.22(b)(3))
4. If an authorization under Standard Provisions – Reporting V.B.3 above is no longer accurate because a different individual or position has responsibility for the overall operation of the facility, a new authorization satisfying the requirements of Standard Provisions – Reporting V.B.3 above must be submitted to the Regional Water Board and State Water Board prior to or together with any reports, information, or applications, to be signed by an authorized representative. (40 C.F.R. § 122.22(c))

5. Any person signing a document under Standard Provisions – Reporting V.B.2 or V.B.3 above shall make the following certification:

“I certify under penalty of law that this document and all attachments were prepared under my direction or supervision in accordance with a system designed to assure that qualified personnel properly gather and evaluate the information submitted. Based on my inquiry of the person or persons who manage the system or those persons directly responsible for gathering the information, the information submitted is, to the best of my knowledge and belief, true, accurate, and complete. I am aware that there are significant penalties for submitting false information, including the possibility of fine and imprisonment for knowing violations.” (40 C.F.R. § 122.22(d))

6. Any person providing the electronic signature for documents described in Standard Provisions – V.B.1, V.B.2, or V.B.3 that are submitted electronically shall meet all relevant requirements of Standard Provisions – Reporting V.B, and shall ensure that all relevant requirements of 40 C.F.R. part 3 (Cross-Media Electronic Reporting) and 40 C.F.R. part 127 (NPDES Electronic Reporting Requirements) are met for that submission. (40 C.F.R § 122.22(e))

C. Monitoring Reports

1. Monitoring results shall be reported at the intervals specified in the MRP (Attachment E) in this Order. (40 C.F.R. § 122.41(l)(4))
2. Monitoring results must be reported on a Discharge Monitoring Report (DMR) form or forms provided or specified by the Regional Water Board or State Water Board for reporting results of monitoring, sludge use, or disposal practices. As of December 21, 2016, all reports and forms must be submitted electronically to the initial recipient defined in Standard Provisions – Reporting V.J and comply with 40 C.F.R. part 3, 40 C.F.R. section 122.22, and 40 C.F.R. part 127. (40 C.F.R. § 122.41(l)(4)(i))
3. If the Permittee monitors any pollutant more frequently than required by this Order using test procedures approved under 40 C.F.R. part 136, or another method required for an industry-specific waste stream under 40 C.F.R. chapter 1, subchapters N or O, the results of such monitoring shall be included in the calculation and reporting of the data submitted in the DMR or sludge reporting form specified by the Regional Water Board. (40 C.F.R. § 122.41(l)(4)(ii))
4. Calculations for all limitations, which require averaging of measurements, shall utilize an arithmetic mean unless otherwise specified in this Order. (40 C.F.R. § 122.41(l)(4)(iii))

D. Compliance Schedules

Reports of compliance or noncompliance with, or any progress reports on, interim and final requirements contained in any compliance schedule of this Order, shall be submitted no later than 14 days following each schedule date. (40 C.F.R. § 122.41(l)(5))

E. Twenty-Four Hour Reporting

1. The Permittee shall report any noncompliance that may endanger health or the environment. Any information shall be provided orally within 24 hours from the time the Permittee becomes aware of the circumstances. A written submission shall also be provided within five (5) days of the time the Permittee becomes aware of the circumstances. The written submission shall contain a description of the noncompliance and its cause; the period of noncompliance, including exact dates and times, and if the noncompliance has not been corrected, the anticipated time it is expected to continue; and steps taken or planned to

reduce, eliminate, and prevent reoccurrence of the noncompliance.
(40 C.F.R. § 122.41(l)(6)(i))

For noncompliance events related to combined sewer overflows, sanitary sewer overflows, or bypass events, these reports must include the data described above (with the exception of time of discovery) as well as the type of event (i.e., combined sewer overflow, sanitary sewer overflow, or bypass event), type of overflow structure (e.g., manhole, combined sewer overflow outfall), discharge volume untreated by the treatment works treating domestic sewage, types of human health and environmental impacts of the event, and whether the noncompliance was related to wet weather.

As of December 21, 2020, all reports related to combined sewer overflows, sanitary sewer overflows, or bypass events must be submitted to the Regional Water Board and must be submitted electronically to the initial recipient defined in Standard Provisions – Reporting V.J. The reports shall comply with 40 C.F.R. part 3, 40 C.F.R. section 122.22, and 40 C.F.R. part 127. The Regional Water Board may also require the Permittee to electronically submit reports not related to combined sewer overflows, sanitary sewer overflows, or bypass events under this section. (40 C.F.R. § 122.41(l)(6)(i))

2. The following shall be included as information that must be reported within 24 hours under this paragraph (40 C.F.R. § 122.41(l)(6)(ii)):
 - a. Any unanticipated bypass that exceeds any effluent limitation in this Order.
(40 C.F.R. § 122.41(l)(6)(ii)(A))
 - b. Any upset that exceeds any effluent limitation in this Order.
(40 C.F.R. § 122.41(l)(6)(ii)(B))
3. The Regional Water Board may waive the above-required written report under this provision on a case-by-case basis if an oral report has been received within 24 hours.
(40 C.F.R. § 122.41(l)(6)(iii))

F. Planned Changes

The Permittee shall give notice to the Regional Water Board as soon as possible of any planned physical alterations or additions to the Facility. Notice is required under this provision only when (40 C.F.R. § 122.41(l)(1)):

1. The alteration or addition to a permitted facility may meet one of the criteria for determining whether a facility is a new source in section 122.29(b)
(40 C.F.R. § 122.41(l)(1)(i)); or
2. The alteration or addition could significantly change the nature or increase the quantity of pollutants discharged. This notification applies to pollutants that are not subject to effluent limitations in this Order. (40 C.F.R. § 122.41(l)(1)(ii))
3. The alteration or addition results in a significant change in the Permittee's sludge use or disposal practices, and such alteration, addition, or change may justify the application of permit conditions that are different from or absent in the existing permit, including notification of additional use or disposal sites not reported during the permit application process or not reported pursuant to an approved land application plan.
(40 C.F.R. § 122.41(l)(1)(iii))

G. Anticipated Noncompliance

The Permittee shall give advance notice to the Regional Water Board of any planned changes in the Facility or activity that may result in noncompliance with this Order's requirements.
(40 C.F.R. § 122.41(l)(2))

H. Other Noncompliance

The Permittee shall report all instances of noncompliance not reported under Standard Provisions – Reporting V.C, V.D, and V.E above at the time monitoring reports are submitted. The reports shall contain the information listed in Standard Provision – Reporting V.E above. For noncompliance events related to combined sewer overflows, sanitary sewer overflows, or bypass events, these reports shall contain the information described in Standard Provision – Reporting V.E and the applicable required data in appendix A to 40 C.F.R. part 127. The Regional Water Board may also require the Permittee to electronically submit reports not related to combined sewer overflows, sanitary sewer overflows, or bypass events under this section. (40 C.F.R. § 122.41(l)(7))

I. Other Information

When the Permittee becomes aware that it failed to submit any relevant facts in a permit application, or submitted incorrect information in a permit application or in any report to the Regional Water Board, State Water Board, or U.S. EPA, the Permittee shall promptly submit such facts or information. (40 C.F.R. § 122.41(l)(8))

J. Initial Recipient for Electronic Reporting Data

The owner, operator, or the duly authorized representative is required to electronically submit NPDES information specified in appendix A to 40 C.F.R. part 127 to the initial recipient defined in 40 C.F.R. section 127.2(b). U.S. EPA will identify and publish the list of initial recipients on its website and in the Federal Register, by state and by NPDES data group [see 40 C.F.R. section 127.2(c)]. U.S. EPA will update and maintain this listing. (40 C.F.R. § 122.41(l)(9))

VI. STANDARD PROVISIONS – ENFORCEMENT

The Regional Water Board is authorized to enforce the terms of this permit under several provisions of the Water Code, including, but not limited to, sections 13385, 13386, and 13387.

VII. ADDITIONAL PROVISIONS – NOTIFICATION LEVELS

A. Publicly-Owned Treatment Works (POTWs)

All POTWs shall provide adequate notice to the Regional Water Board of the following (40 C.F.R. § 122.42(b)):

1. Any new introduction of pollutants into the POTW from an indirect discharger that would be subject to sections 301 or 306 of the CWA if it were directly discharging those pollutants (40 C.F.R. § 122.42(b)(1)); and
2. Any substantial change in the volume or character of pollutants being introduced into that POTW by a source introducing pollutants into the POTW at the time of adoption of this Order (40 C.F.R. § 122.42(b)(2))
3. Adequate notice shall include information on the quality and quantity of effluent introduced into the POTW as well as any anticipated impact of the change on the quantity or quality of effluent to be discharged from the POTW. (40 C.F.R. § 122.42(b)(3))

ATTACHMENT E – MONITORING AND REPORTING PROGRAM (MRP)

Contents

I.	General Monitoring Provisions.....	E-2
II.	Monitoring Locations	E-3
III.	Influent Monitoring Requirements.....	E-3
A.	Monitoring Location INF-001	E-3
IV.	Effluent Monitoring Requirements.....	E-4
A.	Monitoring Location EFF-001.....	E-4
B.	Monitoring Location EFF-002.....	E-5
C.	Monitoring Location EFF-003.....	E-6
V.	Whole Effluent Toxicity (WET) Testing Requirements.....	E-7
A.	Acute Toxicity Testing	E-7
B.	Chronic Toxicity Testing	E-10
C.	Toxicity Reduction Evaluation (TRE) Process.....	E-13
VI.	Land Discharge Monitoring Requirements – Not applicable	E-15
VII.	Recycling Monitoring Requirements – Not Applicable.....	E-15
VIII.	Receiving Water Monitoring Requirements – Surface Water.....	E-15
A.	Arcata Marsh Wildlife Sanctuary (AMWS) Monitoring Locations	E-15
B.	Monitoring Location RSW-001.....	E-15
IX.	Other Monitoring Requirements	E-16
A.	Disinfection Process Monitoring for Ultraviolet Light (UV) Disinfection System (Monitoring Location INT-001)	E-16
B.	Visual Monitoring (Monitoring Locations EFF-001, EFF-002, EFF-003, and RSW-001)	E-16
C.	Sludge Monitoring (Monitoring Location BIO-001)	E-16
X.	Reporting Requirements.....	E-16
A.	General Monitoring and Reporting Requirements	E-16
B.	Self-Monitoring Reports (SMRs).....	E-16
C.	Discharge Monitoring Reports (DMRs)	E-19
D.	Other Reports	E-19
E.	Spill Notification.....	E-22

Tables

Table E-1.	Monitoring Station Locations	E-3
Table E-2.	Influent Monitoring – Monitoring Location INF-001	E-3
Table E-3.	Effluent Monitoring – Monitoring Locations EFF-001	E-4
Table E-4.	Effluent Monitoring – Monitoring Location EFF-002	E-5
Table E-5.	Effluent Monitoring – Monitoring Location EFF-003	E-6
Table E-6.	Receiving Water Monitoring – Monitoring Location RSW-001	E-15
Table E-7.	Monitoring Periods and Reporting Schedule	E-17
Table E-8.	Reporting Requirements for Special Provisions Reports	E-19

ATTACHMENT E – MONITORING AND REPORTING PROGRAM

The Code of Federal Regulations (40 C.F.R. § 122.48) requires that all NPDES permits specify monitoring and reporting requirements. California Water Code (Water Code) section 13383 also authorizes the Regional Water Board to require technical and monitoring reports. This MRP establishes monitoring and reporting requirements that implement federal and California regulations.

I. GENERAL MONITORING PROVISIONS

- A. Wastewater Monitoring Provision.** Composite samples may be taken by a proportional sampling device approved by the Executive Officer or by grab samples composited in proportion to flow. In compositing grab samples, the sampling interval shall not exceed 1 hour.
- B. Supplemental Monitoring Provision.** If the Permittee monitors any pollutant more frequently than required by this Order, using test procedures approved by 40 C.F.R. part 136 or as specified in this Order, the results of such monitoring shall be included in the calculation and reporting of the data submitted in the quarterly and annual discharge monitoring reports.
- C. Data Quality Assurance Provision.** Laboratories analyzing monitoring samples shall be certified by the State Water Resources Control Board (State Water Board) in accordance with the provisions of Water Code section 13176 and must include quality assurance / quality control data with their analytical reports. The Permittee may analyze pollutants with short hold times (e.g., pH, chlorine residual, etc.) with field equipment or its on-site laboratory provided that the Permittee has standard operating procedures (SOPs) that identify quality assurance/quality control procedures to be followed to ensure accurate results.

The Permittee shall keep a manual onsite containing the SOPs followed in this program and must demonstrate sufficient capability to adequately perform these field tests (e.g., qualified and trained employees, properly calibrated and maintained field instruments). The program shall conform to U.S. EPA guidelines or other approved procedures.

- D. Instrumentation and Calibration Provision.** All monitoring instruments and devices used by the Permittee to fulfill the prescribed monitoring program shall be properly maintained and calibrated as necessary to ensure their continued accuracy. All flow measurement devices shall be calibrated no less than the manufacturer's recommended intervals or one-year intervals, (whichever comes first) to ensure continued accuracy of the devices.
- E. Minimum Levels (ML) and Reporting Levels (RL).** Unless otherwise specified by this MRP, all monitoring shall be conducted according to test procedures established at 40 C.F.R. part 136, *Guidelines Establishing Test Procedures for Analysis of Pollutants*. All analyses shall be conducted using the lowest practical quantitation limit achievable using U.S. EPA approved methods. For the purposes of the NPDES program, when more than one test procedure is approved under 40 C.F.R., part 136 for the analysis of a pollutant or pollutant parameter, the test procedure must be sufficiently sensitive as defined at 40 C.F.R. 122.21(e)(3) and 122.44(i)(1)(iv). Where effluent limitations are set below the lowest achievable quantitation limits, pollutants not detected at the lowest practical quantitation limits will be considered in compliance with effluent limitations. Analysis for toxics listed by the California Toxics Rule (CTR) shall also adhere to guidance and requirements contained in the *Policy for Implementation of Toxics Standards for Inland Surface Waters, Enclosed Bays, and Estuaries of California* (2005) (SIP). However, there may be situations when analytical methods are published with MLs that are more sensitive than the MLs for analytical methods listed in the SIP. For instance, U.S. EPA Method 1631E for mercury is not currently listed in SIP Appendix 4, but it is published with an ML of 0.5 ng/L that makes it a sufficiently sensitive analytical method. Similarly, U.S. EPA Method 245.7 for mercury is published with an ML of 5 ng/L.

- F. Discharge Monitoring Report Quality Assurance (DMR-QA) Study.** The Permittee shall ensure that the results of the DMR-QA Study or the most recent Water Pollution Performance Evaluation Study are submitted annually to the State Water Board at the following address:

State Water Resources Control Board
 Quality Assurance Program Officer
 Office of Information Management and Analysis
 1001 I Street, Sacramento, CA 95814

II. MONITORING LOCATIONS

The Permittee shall establish the following monitoring locations to demonstrate compliance with the effluent limitations, discharge specifications, and other requirements in this Order:

Table E-1. Monitoring Station Locations

Discharge Point Name	Monitoring Location Name	Monitoring Location Description
--	INF-001	Untreated influent wastewater collected at the plant headworks at a representative point preceding primary treatment.
--	INT-001	Location for monitoring ultraviolet light (UV) radiation dose and UV transmittance of the UV disinfection system.
001	EFF-001	Location where representative samples of treated wastewater, to be discharged to Humboldt Bay at Discharge Point 001, can be collected at a point following disinfection and prior to contact with Humboldt Bay.
002	EFF-002	Location where representative samples of treated wastewater, to be discharged to the Arcata Marsh Wildlife Sanctuary (AMWS) at Discharge Point 002, can be collected at a point following the UV disinfection system and prior to contact with the AMWS.
--	AMWS	Areas throughout the AMWS representative of various wetland conditions in accordance with the Special Study required under section VI.C.2.a of the Order.
003	EFF-003	Location where representative samples of treated wastewater, to be discharged to the brackish marsh at Discharge Point 003, can be collected at a point prior to contact with the brackish marsh.
--	RSW-001	Receiving water monitoring location at the tide gate following the point at which the brackish marsh discharges into Humboldt Bay.

III. INFLUENT MONITORING REQUIREMENTS

A. Monitoring Location INF-001

- The Permittee shall monitor influent to the Facility at Monitoring Location INF-001 as follows:

Table E-2. Influent Monitoring – Monitoring Location INF-001

Parameter	Units	Sample Type	Minimum Sampling Frequency	Required Analytical Test Method
Influent Flow ¹	Mgd	Meter	Continuous	--
Biochemical Oxygen Demand 5-day @ 20°C (BOD ₅)	mg/L	24-hr Composite	Weekly	Part 136 ²
Total Suspended Solids (TSS)	mg/L	24-hr Composite	Weekly	Part 136 ²

Parameter	Units	Sample Type	Minimum Sampling Frequency	Required Analytical Test Method
Table Notes:				
1. Each quarter, the Permittee shall report the average daily and average monthly flow rates.				
2. Pollutants shall be analyzed using the analytical methods described in 40 C.F.R. part 136 or by methods approved by the Regional Water Board or State Water Board.				

IV. EFFLUENT MONITORING REQUIREMENTS

A. Monitoring Location EFF-001

1. During periods of discharge at Discharge Point 001¹, the Permittee shall monitor treated wastewater to be discharged to Humboldt Bay at Monitoring Location EFF-001, as follows:

Table E-3. Effluent Monitoring – Monitoring Location EFF-001

Parameter	Units	Sample Type	Minimum Sampling Frequency	Required Analytical Test Method
Flow ¹	Mgd	Meter	Continuous	--
Biochemical Oxygen Demand 5-day @ 20°C (BOD ₅)	mg/L	24-hr Composite	Weekly ²	Part 136 ³
Fecal Coliform Bacteria	MPN/100 mL	Grab	Weekly ^{2,4}	Part 136 ³
Enterococci Bacteria ¹²	CFU/100 mL	Grab	Weekly ^{2,4}	Part 136 ³
pH	standard units	Grab	Daily ^{5,6}	Part 136 ³
Total Suspended Solids (TSS)	mg/L	24-hr Composite	Weekly ²	Part 136 ³
Cyanide, Total (as CN)	µg/L	Grab	Monthly ^{7,8}	Part 136 ³
TCDD Equivalents ⁹	µg/L	Grab	Quarterly ^{7,8}	Part 136 ³
Ammonia Nitrogen, Total (as N)	mg/L	Grab	Monthly ^{7,8}	Part 136 ³
Ammonia Impact Ratio	Ratio	Calculation	Monthly ⁸	
Chlorine, Total Residual ¹⁰	mg/L	Meter	Continuous	Part 136 ³
Nitrate Nitrogen, Total (as N)	mg/L	Grab	Quarterly ⁸	Part 136 ³
Phosphorus, Total (as P)	mg/L	Grab	Quarterly ⁸	Part 136 ³
Settleable Solids	ml/L	Grab	Daily ⁶	Part 136 ³
Temperature	°C	Grab	Daily	
Acute Toxicity ¹¹	% Survival, Pas or Fail, and % Effect	Grab	Annually ⁸	See Section V Below
Chronic Toxicity ¹¹	Pass or Fail, and % Effect	Grab	Quarterly ⁸	See Section V Below

¹ The routine monitoring requirements are in effect until the Permittee begins discharging effluent to EFF-003. Once discharge begins at EFF-003, EFF-001 will be used for the discharge of emergency flows over 5.9 mgd. Monitoring at EFF-001 will then be required for each discharge event.

Parameter	Units	Sample Type	Minimum Sampling Frequency	Required Analytical Test Method
Table Notes:				
1. For each month, the Permittee shall report the average daily and average monthly flow rates.				
2. Accelerated monitoring (weekly monitoring frequency). If two consecutive weekly test results exceed an effluent limitation, the Permittee shall take two samples each of the 2 weeks following receipt of the second sample result. During the intervening period, the Permittee shall take steps to identify the cause of the exceedance and take steps needed to return to compliance.				
3. Pollutants shall be analyzed using the analytical methods described in 40 C.F.R. part 136 or by methods approved by the Regional Water Board or State Water Board, such as with the current edition of <i>Standard Methods for Examination of Water and Wastewater</i> (American Public Health Administration).				
4. Fecal and enterococci coliform bacteria samples may be collected at any point downstream of the disinfection process.				
5. pH, salinity and temperature monitoring at RSW-001 shall be recorded at the time of ammonia sampling.				
6. Accelerated Monitoring (daily monitoring frequency). If a test result exceeds an effluent limitation, the Permittee shall increase monitoring frequency to a minimum of twice a day for a week to evaluate whether an exceedance is persisting. If two or more samples in a week exceed an effluent limitation, the Permittee shall take steps to identify the cause of the exceedance and take steps needed to return to compliance.				
7. Accelerated monitoring (monthly and annual monitoring frequency). If a test result exceeds an effluent limitation, the Permittee shall take two more samples, one within 7 days and one within 14 days following receipt of the initial sample result. During the intervening period, the Permittee shall take steps to identify the cause of the exceedance and take steps needed to return to compliance.				
8. When Discharge Point 001 is used for emergency discharges of flows exceeding 5.9 mgd under the upgraded Facility configuration, effluent monitoring at Monitoring Location EFF-001 shall be conducted annually when discharge occurs during a calendar year. The Permittee shall cease sample collection after the discharge ends. If the duration of the discharge is less than 24 hours or the duration required for toxicity testing, the Permittee shall conduct the analyses using the available sample type/volume.				
9. The sum of concentrations of chlorinated dibenzodioxins (2,3,7,8-CDDs) and chlorinated dibenzofurans (2,3,7,8-CDFs) multiplied by their respective toxicity factors, as identified in the <i>Policy for Implementation of Toxics Standards for Inland Surface Waters, Enclosed Bays, and Estuaries of California</i> (State Implementation Policy or SIP).				
10. Chlorine residual monitoring at Monitoring Location EFF-001 shall demonstrate if the discharge complies with effluent limits in Table 4 and Table 5 during periods of discharge to Humboldt Bay. Samples collected to demonstrate complete dechlorination shall be collected at a point following disinfection and prior to discharge to Humboldt Bay. All chlorine residual measurements shall be reported as total chlorine residual. This monitoring requirement applies when chlorine is used as a disinfection system.				
11. Whole effluent acute and chronic toxicity shall be monitored in accordance with the requirements in section V of this MRP.				
12. The Permittee shall began monitoring for enterococci, from an ELAP accredited lab, by June 1, 2021.				

B. Monitoring Location EFF-002

1. The Permittee shall monitor secondary treated wastewater to be discharged to the AMWS at Monitoring Location EFF-002, as follows:

Table E-4. Effluent Monitoring – Monitoring Location EFF-002

Parameter	Units	Sample Type	Minimum Sampling Frequency	Required Analytical Test Method
Flow ¹	mgd	Meter	Continuous	--
Biochemical Oxygen Demand 5-day @ 20°C (BOD ₅)	mg/L	24-hr Composite	Weekly ²	Part 136 ³
Enterococci Bacteria ⁸	CFU/100 mL	Grab	Weekly ^{2,4}	Part 136 ³
Fecal Coliform Bacteria	MPN/100 mL	Grab	Weekly ^{2,4}	Part 136 ³
pH	standard units	Grab	Daily ⁵	Part 136 ³
Total Suspended Solids (TSS)	mg/L	24-hr Composite	Weekly ²	Part 136 ³
Chlorine, Total Residual ⁶	mg/L	Meter	Continuous ⁷	Part 136 ³
Settleable Solids	ml/L	Grab	Daily ⁵	Part 136 ³

Parameter	Units	Sample Type	Minimum Sampling Frequency	Required Analytical Test Method
Table Notes:				
1. For each month, the Permittee shall report the average daily and average monthly flow rates.				
2. Accelerated monitoring (weekly monitoring frequency). If two consecutive weekly test results exceed an effluent limitation, the Permittee shall take two samples each of the 2 weeks following receipt of the second sample result. During the intervening period, the Permittee shall take steps to identify the cause of the exceedance and take steps needed to return to compliance.				
3. Pollutants shall be analyzed using the analytical methods described in 40 C.F.R. part 136 or by methods approved by the Regional Water Board or State Water Board, such as with the current edition of <i>Standard Methods for Examination of Water and Wastewater</i> (American Public Health Administration).				
4. Fecal coliform bacteria samples may be collected at any point downstream of the UV disinfection process.				
5. Accelerated Monitoring (daily monitoring frequency). If a test result exceeds an effluent limitation, the Permittee shall increase monitoring frequency to a minimum of twice a day for a week to evaluate whether an exceedance is persisting. If two or more samples in a week exceed an effluent limitation, the Permittee shall take steps to identify the cause of the exceedance and take steps needed to return to compliance.				
6. Chlorine residual monitoring at Monitoring Location EFF-002 shall demonstrate that chlorine residual complies with effluent limits in Table 4 during periods of discharge to the AMWS. Samples collected to demonstrate complete dechlorination shall be collected at a point following disinfection and prior to discharge to the AMWS. All chlorine residual measurements shall be reported as total chlorine residual.				
7. Monitoring for total chlorine residual is required at Monitoring Location EFF-002 until the Permittee submits written certification that a chlorine-based disinfection system is no longer in use for discharges through Discharge Point 002, chlorine byproducts are no longer present, and chlorine-containing chemicals are not added to the treatment process for wastewater discharged through Discharge Point 002. The monitoring change may only be implemented after the Permittee receives written approval from the Executive Officer.				
8. The Permittee shall begin monitoring for enterococci, from an ELAP accredited lab, by June 1, 2021.				

C. Monitoring Location EFF-003

- The Permittee shall monitor secondary treated wastewater to be discharged to the brackish marsh at Monitoring Location EFF-003¹, as follows:

Table E-5. Effluent Monitoring – Monitoring Location EFF-003

Parameter	Units	Sample Type	Minimum Sampling Frequency	Required Analytical Test Method
Flow ¹	Mgd	Meter	Continuous	--
pH	standard units	Grab	Daily ^{3,4}	Part 136 ²
Biochemical Oxygen Demand 5-day @ 20°C (BOD ₅) ¹²	mg/L	24-hr Composite	Weekly ³	Part 136 ²
Total Suspended Solids (TSS) ¹²	mg/L	24-hr Composite	Weekly ³	Part 136 ²
Fecal Coliform Bacteria	MPN/100 mL	Grab	Weekly ^{3,13}	Part 136 ²
Copper, Total Recoverable	µg/L	Grab	Monthly ^{5,6}	Part 136 ²
Cyanide, Total (as CN)	µg/L	Grab	Monthly ⁵	Part 136 ²
TCDD Equivalents ⁷	µg/L	Grab	Quarterly	Part 136 ²
Ammonia Nitrogen, Total (as N)	mg/L	Grab	Monthly ^{4,5}	Part 136 ²
Hardness, Total (as CaCO ₃)	mg/L	Grab	Monthly ⁶	Part 136 ²
Nitrate Nitrogen, Total (as N)	mg/L	Grab	Quarterly	Part 136 ²
Phosphorus, Total (as P)	mg/L	Grab	Quarterly	Part 136 ²
Settleable Solids	ml/L	Grab	Daily ²	Part 136 ²

¹ The Permittee will start monitoring for constituents listed in Table E-5 once discharge from Discharge Point 003 commences.

Parameter	Units	Sample Type	Minimum Sampling Frequency	Required Analytical Test Method
CTR Priority Pollutants ⁸	µg/L	24-hr Composite ⁹	Twice per permit term ¹⁰	Part 136 ²
Acute Toxicity ¹¹	% Survival, Pass or Fail, and % Effect	Grab	Annually	See Section V Below
Chronic Toxicity ¹¹	Pass or Fail, and % Effect	Grab	Quarterly	See Section V Below

Table Notes:

- For each month, the Permittee shall report the average daily and average monthly flow rates.
- Pollutants shall be analyzed using the analytical methods described in 40 C.F.R. part 136 or by methods approved by the Regional Water Board or State Water Board, such as with the current edition of *Standard Methods for Examination of Water and Wastewater* (American Public Health Administration).
- Accelerated Monitoring (daily monitoring frequency). If a test result exceeds an effluent limitation, the Permittee shall increase monitoring frequency to a minimum of twice a day for a week to evaluate whether an exceedance is persisting. If two or more samples in a week exceed an effluent limitation, the Permittee shall take steps to identify the cause of the exceedance and take steps needed to return to compliance.
- pH, salinity and temperature monitoring at RSW-001 shall be recorded at the time of ammonia sampling.
- Accelerated monitoring (monthly and quarterly monitoring frequency). If a test result exceeds an effluent limitation, the Permittee shall take two more samples, one within 7 days and one within 14 days following receipt of the initial sample result. During the intervening period, the Permittee shall take steps to identify the cause of the exceedance and take steps needed to return to compliance.
- Monitoring for effluent and receiving water hardness shall be conducted concurrently with effluent sampling for copper.
- The sum of concentrations of chlorinated dibenzodioxins (2,3,7,8-CDDs) and chlorinated dibenzofurans (2,3,7,8-CDFs) multiplied by their respective toxicity factors, as identified in the *Policy for Implementation of Toxics Standards for Inland Surface Waters, Enclosed Bays, and Estuaries of California* (State Implementation Policy or SIP).
- Those pollutants identified by the California Toxics Rule at 40 C.F.R. section 131.38. Hardness shall be monitored concurrently with the CTR priority pollutant sample.
- CTR priority pollutant samples shall be collected using 24-hour composite sampling, except for pollutants that are volatile. Samples for volatile pollutants may be collected as a grab sample.
- CTR priority pollutant sampling shall be completed no later than **June 1, 2023** during a period of discharge to the brackish marsh. Effluent and receiving water monitoring shall occur concurrently.
- Whole effluent acute and chronic toxicity shall be monitored in accordance with the requirements in section V of this MRP.
- BOD and TSS shall be monitored at EFF-003 for compliance with Technology-Based Effluent Limitations after Phase One and before Phase Two of the Proposed Upgrade Project is complete. Once Phase Two of the Proposed Upgrade Project is completed, monitoring for BOD and TSS at EFF-003 can be discontinued as compliance with TBELs will be determined at EFF-002.
- Fecal coliform bacteria samples may be collected at any point downstream of the disinfection process. Monitoring for fecal coliform shall start once Phase One of the Proposed Upgrade Project is completed. Monitoring for fecal coliform shall be discontinued at EFF-003 once Phase Two of the Proposed Upgrade Project has been completed.

V. WHOLE EFFLUENT TOXICITY (WET) TESTING REQUIREMENTS

A. Acute Toxicity Testing

The Permittee shall conduct acute WET testing in accordance with the following acute toxicity testing requirements.

- Test Frequency.** The Permittee shall conduct acute WET testing in accordance with the schedule established by this MRP while discharging at Discharge Points 001 and/or 003, as summarized in Tables E-3 and E-5, above.
- Discharge In-stream Waste Concentration (IWC) for Acute Toxicity.** The IWC for this discharge is 100 percent effluent.¹

¹ The acute toxicity test shall be conducted using 100 percent effluent collected at Monitoring Locations EFF-001 and EFF-003.

3. **Sample Volume and Holding Time.** The total sample volume shall be determined by the specific toxicity test method used. Sufficient sample volume shall be collected to perform the required toxicity test. All toxicity tests shall be conducted as soon as possible following sample collection. No more than 36 hours (holding time) shall elapse before the conclusion of sample collection and test initiation.
4. **Test Species and Test Methods.** The Permittee shall conduct the following acute toxicity tests using an invertebrate and a vertebrate in accordance with the species and test methods in *Methods for Measuring the Acute Toxicity of Effluents and Receiving Waters to Freshwater and Marine Organisms* (U.S. EPA Report No. EPA-821-R-02-012, 5th edition or subsequent editions). In no case shall these species be substituted with another test species unless written authorization from the Executive Officer is received. Species and test methods shall be selected from the following:
 - a. A 96-hour static renewal toxicity test with an invertebrate, the water flea, *Ceriodaphnia dubia* (Survival Test Method 2002.0).
 - b. A 96-hour static renewal or 96-hour static non-renewal toxicity test with an invertebrate, the mysid shrimp, *Mysidopsis bahia* (Survival Test Method 2007.0).
 - c. A 96-hour static renewal toxicity test with a vertebrate, the rainbow trout, *Oncorhynchus mykiss* (Survival Test Method 2019.0).
 - d. A 96-hour static renewal or 96-hour static non-renewal toxicity test with a vertebrate, the sheepshead minnow, *Cyprinodon variegatus* (Survival Test Method 2004.0).
 - e. A 96-hour static renewal or 96-hour static non-renewal toxicity test with a vertebrate, the fathead minnow, *Pimephales promelas* (Survival Test Method 2000.0).
5. **Species Sensitivity Screening.** Species sensitivity screening shall be conducted during this Order's first required sample collection. The Permittee shall collect a single effluent sample and concurrently conduct acute toxicity tests using an invertebrate and a fish species identified in section V.A.4, above. This sample shall also be analyzed for the parameters required for the discharge. The species that exhibits the highest¹ "Percent (%) Effect" at the discharge IWC during species sensitivity screening shall be used for routine acute toxicity monitoring during the permit term².
6. **Quality Assurance and Additional Requirements.** Quality assurance measures, instructions, and other recommendations and requirements are found in the test methods manual referenced in section V.A.4, above. Additional requirements are specified below.
 - a. The discharge is subject to determination of "Pass" or "Fail" and "Percent (%) Effect" from acute toxicity tests using the Test of Significant Toxicity (TST) approach described in *National Pollutant Discharge Elimination System Test of Significant Toxicity Implementation Document* (EPA 833-R10-003, 2010), Appendix A, Figure A-1, and Table A-1. The null hypothesis (H_0) for the TST approach is: mean discharge IWC response $\leq 0.80 \times$ mean control response. A test result that rejects this null hypothesis is reported as "Pass". A test result that does not reject this null hypothesis is reported as "Fail". The relative "Percent (%) Effect" at the discharge IWC is defined and reported as: $((\text{mean control response} - \text{mean discharge IWC response}) \div \text{mean control response}) \times 100$.

¹ If the Percent Effect is less than or equal to 0% for each species, the Permittee shall either perform the test procedures again or use the species that was most sensitive during the previous permit term.

² Once the Proposed Treatment Upgrade Project is complete, the Permittee shall perform Species Sensitivity Screening for the new process.

- b. If the effluent toxicity test does not meet the minimum effluent test acceptability criteria (TAC) specified in the referenced test method, then the Permittee shall re-sample and re-test within 7 days.
 - c. Dilution water and control water shall be laboratory water prepared and used as specified in the test methods manual. If dilution water and control water is different from test organism culture water, then a second control using culture water shall also be used.
 - d. Test procedures related to pH control, sample filtration, aeration, temperature control and sample dechlorination shall be performed in accordance with the U.S. EPA method and fully explained and justified in each acute toxicity report submitted to the Regional Water Board. The control of pH in acute toxicity tests is allowed, provided the test pH is maintained at the effluent pH measured at the time of sample collection, and the control of pH is done in a manner that has the least influence on the test water chemistry and on the toxicity of other pH sensitive materials such as some heavy metals, sulfide and cyanide.
 - e. **Ammonia Toxicity.** The acute toxicity test shall be conducted without modifications to eliminate ammonia toxicity.
7. **Notification.** The Permittee shall notify the Regional Water Board verbally within 72 hours and in writing 14 days after receipt of test results exceeding the acute toxicity effluent limitation during regular or accelerated monitoring. The notification shall describe actions the Permittee has taken or will take to investigate and correct the cause(s) of toxicity. It may also include a status report on any actions required by this Order, with a schedule for actions not yet completed. If no actions have been taken, the reasons shall be given.
8. **Accelerated Monitoring Requirements.** If the result of any acute toxicity test fails to meet the single test minimum limitation (70 percent survival), and the testing meets all TAC, the Permittee shall take two more samples, one within 14 days and one within 21 days following receipt of the initial sample result. If any one of the additional samples do not comply with the three-sample median minimum limitation (90 percent survival), the Permittee shall initiate a Toxicity Reduction Evaluation (TRE) in accordance with section V.C of the MRP. If the two additional samples are in compliance with the acute toxicity requirement and testing meets all TAC, then a TRE will not be required. If the discharge stops before additional samples can be collected, the Permittee shall contact the Executive Officer within 21 days with a plan to demonstrate compliance with the effluent limitation.
9. **Reporting.** The Self-Monitoring Report (SMR) shall include a full laboratory report for each toxicity test (WET report). The WET report shall be prepared using the format and content of section 12 (Report Preparation) of *Methods for Measuring the Acute Toxicity of Effluents and Receiving Waters to Freshwater and Marine Organisms* (U.S. EPA Report No. EPA-821-R-02-012, 5th edition or subsequent editions), including:
- a. The toxicity test results in percent (%) survival for the 100 percent effluent sample.
 - b. The toxicity test results for the TST approach, reported as “Pass” or “Fail” and “Percent (%) Effect” at the acute toxicity IWC for the discharge.
 - c. Water quality measurements for each toxicity test (e.g., pH, dissolved oxygen, temperature, conductivity, hardness, salinity, chlorine, ammonia).
 - d. TRE/Toxicity Identification Evaluation (TIE) results. The Executive Officer shall be notified no later than 30 days from completion of each aspect of TRE/TIE analyses.

- e. Statistical program (e.g., TST calculator, CETIS, etc.) output results for each toxicity test.

B. Chronic Toxicity Testing

The Permittee shall conduct chronic toxicity testing in accordance with the following chronic toxicity testing requirements:

1. **Test Frequency.** The Permittee shall conduct chronic toxicity testing in accordance with the schedule established by this MRP while discharging at Discharge Point 001 and/or 003, as summarized in Tables E-3 and E-5, above.
2. **Discharge In-stream Waste Concentration (IWC) for Chronic Toxicity.** The chronic toxicity IWC for this discharge is 100 percent effluent.¹
3. **Sample Volume and Holding Time.** The total sample volume shall be determined by the specific toxicity test method used. Sufficient sample volume shall be collected to perform the required toxicity test. All toxicity tests shall be conducted as soon as possible following sample collection. For toxicity tests requiring renewals, a minimum of three 24-hour composite samples shall be collected. The lapsed time (holding time) from sample collection to first use of each sample must not exceed 36 hours.
4. **Test Species and Test Methods.** The Permittee shall conduct chronic toxicity tests using a vertebrate, an invertebrate, and a plant, in accordance with species and test methods in *Short-Term Methods for Estimating the Chronic Toxicity of Effluents and Receiving Water to Freshwater Organisms* (U.S. EPA Report No. EPA-821-R-02-013, or subsequent editions) and *Short-term Methods for Estimating the Chronic Toxicity of Effluents and Receiving Waters to West Coast Marine and Estuarine Organisms* (EPA/600/R-95/136, 1995). Artificial sea salts or hypersaline brine prepared from natural seawater shall be used to increase sample salinity. In no case shall these species be substituted with another test species unless written authorization from the Executive Officer is received. Species and test methods shall be selected from the following:
 - a. A 7-day static renewal toxicity test with a vertebrate, the fathead minnow, *Pimephales promelas* (Larval Survival and Growth Test Method 1000.0).
 - b. A static renewal toxicity test with the topsmelt, *Atherinops affinis* (Larval Survival and Growth Test Method 1006.011).
 - c. A static renewal toxicity test with an invertebrate, the water flea, *Ceriodaphnia dubia* (Survival and Reproduction Test Method 1002.0).
 - d. A static non-renewal toxicity test with the purple sea urchin, *Strongylocentrotus purpuratus*, and the sand dollar, *Dendraster excentricus* (Fertilization Test Method 1008.0), or a static non-renewal toxicity test with the red abalone, *Haliotis rufescens* (Larval Shell Development Test Method).
 - e. A 96-hour static renewal toxicity test with a plant, the green algae, *Selenastrum capricornutum* (also named *Raphidocelis subcapitata*) (Growth Test Method 1003.0).
 - f. A static non-renewal toxicity test with the giant kelp, *Macrocystis pyrifera* (Germination and Growth Test Method 1009.0).
5. **Species Sensitivity Screening.** Species sensitivity screening shall be conducted during this Order's first required sample collection. The Permittee shall collect a single effluent sample

¹ The chronic toxicity test shall be conducted using a series of five dilutions and a control. The series shall consist of the following dilutions: 12.5, 25, 50, 75, and 100 percent. Compliance determination will be based on the IWC (100 percent effluent) and a control as further described in Fact Sheet section IV.C.5.c.

and concurrently conduct three chronic toxicity tests using a fish, an invertebrate, and an algae species identified in section V.B.4, above. This sample shall also be analyzed for the parameters required for the discharge. The species that exhibits the highest “Percent (%) Effect” at the discharge IWC during species sensitivity screening shall be used for routine monitoring during the permit term¹.

- 6. Quality Assurance and Additional Requirements.** Quality assurance measures, instructions, and other recommendations and requirements are found in the test methods manual previously referenced. Additional requirements are specified below.
- a. The discharge is subject to determination of “Pass” or “Fail” and “Percent (%) Effect” for chronic toxicity tests using the TST approach described in *National Pollutant Discharge Elimination System Test of Significant Toxicity Implementation Document* (EPA 833-R10-003, 2010), Appendix A, Figure A-1, and Table A-1. The null hypothesis (H_0) for the TST approach is mean discharge IWC response $0.75 \times$ mean control response. A test result that rejects this null hypothesis is reported as “Pass”. A test result that does not reject this null hypothesis is reported as “Fail”. The relative “Percent (%) Effect” at the discharge IWC is defined and reported as: $((\text{mean control response} - \text{mean discharge IWC response}) \div \text{mean control response}) \times 100$. The IWC for the chronic toxicity test is 100 percent effluent.
 - b. If the effluent toxicity test does not meet the minimum effluent or reference toxicant TAC specified in the referenced test method, then the Permittee shall re-sample and re-test within 14 days.
 - c. Dilution water and control water shall be laboratory water prepared and used as specified in the test methods manual. If dilution water and control water are different from test organism culture water, then a second control using culture water shall also be used.
 - d. Monthly reference toxicant testing is sufficient. All reference toxicant test results should be reviewed and reported.
 - e. The Permittee shall perform toxicity tests on final effluent samples. Chlorine and ammonia shall not be removed from the effluent sample prior to toxicity testing, unless explicitly authorized under this section of the MRP and the rationale is explained in the Fact Sheet (Attachment F).
 - f. **Ammonia Removal.** Except with prior approval from the Executive Officer of the Regional Water Board, ammonia shall not be removed from bioassay samples. The Permittee must demonstrate the effluent toxicity is caused by ammonia because of increasing test pH when conducting the toxicity test. It is important to distinguish the potential toxic effects of ammonia from other pH sensitive chemicals, such as certain heavy metals, sulfide, and cyanide. The following may be steps to demonstrate that the toxicity is caused by ammonia and not other toxicants before the Executive Officer would allow for control of pH in the test.
 - i. There is consistent toxicity in the effluent and the maximum pH in the toxicity test is in the range to cause toxicity due to increased pH.
 - ii. Chronic ammonia concentrations in the effluent are greater than 4 mg/L total ammonia.

¹ Once the Proposed Treatment Upgrade Project is complete, the Permittee shall perform Species Sensitivity Screening for the new process.

- iii. Conduct graduated pH tests as specified in the TIE methods. For example, mortality should be higher at pH 8 and lower at pH 6.
- iv. Treat the effluent with a zeolite column to remove ammonia. Mortality in the zeolite treated effluent should be lower than the non-zeolite treated effluent. Then add ammonia back to the zeolite-treated samples to confirm toxicity due to ammonia.

When it has been demonstrated that toxicity is due to ammonia because of increasing test pH, pH may be controlled using appropriate procedures, which do not significantly alter the nature of the effluent.

- 7. **Notification.** The Permittee shall notify the Regional Water Board verbally within 72 hours and in writing within 14 days after the receipt of a result of “Fail” during routine or accelerated monitoring.
- 8. **Accelerated Monitoring Requirements.** Accelerated monitoring for chronic toxicity is triggered when a chronic toxicity test, analyzed using the TST approach, results in “Fail” and the “Percent Effect” is ≥ 0.50 . Within 24 hours of the time the Permittee becomes aware of a summary result of “Fail”, the Permittee shall implement an accelerated monitoring schedule consisting of four toxicity tests—consisting of 5-effluent concentrations (including the discharge IWC) and a control—conducted at approximately 2-week intervals, over an 8 week period. If each of the accelerated toxicity tests results is “Pass,” the Permittee shall return to routine monitoring for the next monitoring period. If one of the accelerated toxicity test results is “Fail”, the Permittee shall immediately implement the TRE Process conditions set forth in section V.C, below. If the discharge will cease before the additional samples can be collected, the Permittee shall contact the Executive Officer within 21 days with a plan to address elevated levels of chronic toxicity in effluent and/or receiving waters.

9. Reporting

- a. **Routine Reporting.** Chronic toxicity monitoring results shall be submitted with the quarterly SMR for the month that chronic toxicity monitoring was performed. Routine reporting shall include the following in order to demonstrate compliance with permit requirements:
 - i. WET reports shall include the contracting laboratory’s complete report provided to the Permittee and shall be consistent with the appropriate “Report Preparation and Test Review” sections of the methods manual and this MRP. The WET test reports shall contain a narrative report that includes details about WET test procedures and results, including the following:
 - (a) Receipt and handling of the effluent sample that includes a tabular summary of initial water quality characteristics (e.g., pH, dissolved oxygen, temperature, conductivity, hardness, salinity, chlorine, ammonia);
 - (b) The source and make-up of the lab control/diluent water used for the test;
 - (c) Any manipulations done to lab control/diluent and effluent such as filtration, nutrient addition, etc.;
 - (d) Tabular summary of test results for control water and each effluent dilution and statistics summary to include calculation of the No Observed Effect Concentration (NOEC), TUC, and IC25;
 - (e) Identification of any anomalies or nuances in the test procedures or results;
 - (f) WET test results shall include, at a minimum, for each test:

- (1) Sample date(s);
- (2) Test initiation date;
- (3) Test species;
- (4) Determination of “Pass” or “Fail” and “Percent (%) Effect” following the TST hypothesis testing approach in *National Pollutant Discharge Elimination System Test of Significant Toxicity Implementation Document* (EPA 833-R-10-003, 2010). The “Percent (%) Effect” shall be calculated as follows:

$$\text{“Percent (\%) Effect” (or Effect, in \%)} = ((\text{Control mean response} - \text{IWC mean response}) \div \text{Control mean response}) \times 100$$
- (5) Endpoint values for each dilution (e.g., number of young, growth rate, percent survival);
- (6) NOEC value(s) in percent effluent;
- (7) IC15, IC25, IC40, and IC50 values (or EC15, EC25...etc.) in percent effluent;
- (8) TUC values (100/NOEC);
- (9) Mean percent mortality (\pm s.d.) after 96 hours in 100 percent effluent (if applicable);
- (10) NOEC and LOEC values for reference toxicant test(s);
- (11) IC50 or EC50 value(s) for reference toxicant test(s);
- (12) Available water quality measurements for each test (e.g., pH, dissolved oxygen, temperature, conductivity, hardness, salinity, ammonia);
- (13) Statistical methods used to calculate endpoints;
- (14) The statistical program (e.g., TST calculator, CETIS, etc.) output results, which includes the calculation of percent minimum significant difference (PMSD); and
- (15) Results of applicable reference toxicant data with the statistical output page identifying the species, NOEC, LOEC, type of toxicant, dilution water used, concentrations used, PMSD and dates tested; the reference toxicant control charts for each endpoint, to include summaries of reference toxicant tests performed by the contracting laboratory; and any information on deviations from standard test procedures or problems encountered in completing the test and how the problems were resolved.

- b. **TRE/TIE results.** The Executive Officer shall be notified no later than 30 days from completion of each aspect of TRE/TIE analyses. TRE/TIE results shall be submitted to the Regional Water Board within 60 days of completion.

C. Toxicity Reduction Evaluation (TRE) Process

1. **TRE Work Plan.** The Permittee submitted a revised TRE Work Plan to the Regional Water Board on **January 17, 2018**. The Permittee’s TRE Work Plan shall be reviewed by the Permittee once every five years and updated as necessary in order to remain current and applicable to the discharge and discharge facilities.

The Permittee shall notify the Regional Water Board of this review and submit any revisions of the TRE Work Plan within 90 days of the notification, to be ready to respond to toxicity events. The TRE Work Plan shall describe the steps the Permittee intends to follow if toxicity is detected, and should include at least the following items:

- a. A description of the investigation and evaluation techniques that would be used to identify potential causes and sources of toxicity, effluent variability, and treatment system efficiency.
 - b. A description of the Facility's methods of maximizing in-house treatment efficiency, good housekeeping practices, and a list of all chemicals used in the operation of this Facility.
 - c. If a TIE is necessary, an indication of the person who would conduct the TIEs (i.e., an in-house expert or an outside contractor).
2. **Preparation and Implementation of a Detailed TRE Work Plan.** If one of the accelerated toxicity tests described in section V.A.8 (above) does not comply with the three sample median minimum limitation (90 percent survival) or in section V.B.8 (above) results in "Fail", the Permittee shall immediately initiate a TRE using EPA manual *Generalized Methodology for Conducting Industrial Toxicity Reduction Evaluations* (EPA/600/2-88/070, 1989) and within 30 days of receipt submit the accelerated monitoring result to the Regional Water Board Executive Officer. The Permittee shall also submit a Detailed TRE Work Plan, which shall follow the generic TRE Work Plan revised as appropriate for the toxicity event described in section V.A.8 or V.B.8 of this MRP. The Detailed TRE Work Plan shall include the following information, and comply with additional conditions set by the Regional Water Board Executive Officer:
 - a. Further actions by the Permittee to investigate, identify, and correct causes of toxicity.
 - b. Actions the Permittee will take to mitigate effects of the discharge and prevent the recurrence of toxicity.
 - c. A schedule for these actions, progress reports, and the final report.
3. **TIE Implementation.** The Permittee may initiate a TIE as part of a TRE to identify the causes of toxicity using the same species and test methods and, as guidance, EPA manuals: *Methods for Aquatic Toxicity Identification Evaluations: Phase I Toxicity Characterization Procedures* (EPA/600/6-91/003, 1991); *Methods for Aquatic Toxicity Identification Evaluations, Phase II Toxicity Identification Procedures for Samples Exhibiting Acute and Chronic Toxicity* (EPA/600/R-92/080, 1993); *Methods for Aquatic Toxicity Identification Evaluations, Phase III Toxicity Confirmation Procedures for Samples Exhibiting Acute and Chronic Toxicity* (EPA/600/R-92/081, 1993); and *Marine Toxicity Identification Evaluation (TIE): Phase I Guidance Document* (EPA/600/R-96-054, 1996). The TIE should be conducted on the species demonstrating the most sensitive toxicity response.
4. Many recommended TRE elements parallel required or recommended efforts for source control, pollution prevention, and storm water control programs. TRE efforts should be coordinated with such efforts. As toxic substances are identified or characterized, the Permittee shall continue the TRE by determining the sources and evaluating alternative strategies for reducing or eliminating the substances from the discharge. All reasonable steps shall be taken to reduce toxicity to levels consistent with toxicity evaluation parameters.

5. The Permittee shall conduct routine effluent monitoring for the duration of the TRE process. Additional accelerated monitoring and TRE Work Plans are not required once a TRE has begun.
6. The Regional Water Board recognizes that toxicity may be episodic and identification of the causes and reduction of sources of toxicity may not be successful in all cases. The TRE may be ended at any stage, pending Regional Water Board Executive Officer approval, if monitoring finds there is no longer toxicity.

VI. LAND DISCHARGE MONITORING REQUIREMENTS – NOT APPLICABLE

This Order does not authorize discharges to land.

VII. RECYCLING MONITORING REQUIREMENTS – NOT APPLICABLE

This Order does not authorize discharges of recycled water.

VIII. RECEIVING WATER MONITORING REQUIREMENTS – SURFACE WATER

A. Arcata Marsh Wildlife Sanctuary (AMWS) Monitoring Locations

Monitoring of the AMWS shall be implemented in accordance with the work plan approved by the Executive Officer in accordance with section VI.C.2.a of the Order. Monitoring results required in accordance with the approved plan shall be submitted annually, by March 1 each year.

B. Monitoring Location RSW-001

1. The Permittee shall monitor the receiving water at Monitoring Location RSW-001 during periods of discharge to the brackish marsh, as follows:

Table E-6. Receiving Water Monitoring – Monitoring Location RSW-001

Parameter	Units	Sample Type	Minimum Sampling Frequency	Required Analytical Test Method
pH	standard units	Grab	Weekly ¹	Part 136 ²
Dissolved Oxygen	mg/L	Grab	Weekly	Part 136 ²
Floatables/Discoloration	--	Visual	Monthly	--
Hardness, Total (as CaCO ₃)	mg/L	Grab	Monthly	Part 136 ²
Nitrate Nitrogen, Total (as N)	mg/L	Grab	Monthly	Part 136 ²
Salinity	Ppt	Grab	Weekly ¹	Part 136 ²
Specific Conductance	µmhos/cm	Grab	Weekly	Part 136 ²
Temperature	°C	Grab	Weekly ¹	Part 136 ²
Total Dissolved Solids	mg/L	Grab	Monthly	Part 136 ²
Turbidity	NTU	Grab	Monthly	Part 136 ²
CTR Priority Pollutants ³	µg/L	Grab	Twice per permit term ⁴	Part 136 ²

Table Notes:

1. pH, salinity and temperature monitoring must coincide with monthly effluent monitoring for ammonia.
2. Pollutants shall be analyzed using the analytical methods described in 40 C.F.R. part 136 or by methods approved by the Regional Water Board or State Water Board, such as with the current edition of *Standard Methods for Examination of Water and Wastewater* (American Public Health Administration).
3. Those pollutants identified by the California Toxics Rule at 40 C.F.R. section 131.38. Hardness shall be monitored concurrently with the CTR priority pollutant sample.
4. CTR priority pollutant sampling shall be completed no later than **June 1, 2023** during a period of discharge to the brackish marsh. Effluent and receiving water monitoring shall occur concurrently.

IX. OTHER MONITORING REQUIREMENTS

A. Disinfection Process Monitoring for Ultraviolet Light (UV) Disinfection System (Monitoring Location INT-001)¹

1. Monitoring Location INT-001

- a. **Monitoring.** The UV transmittance (UVT) of the effluent from the UV disinfection system shall be monitored continuously and recorded at Monitoring Location INT-001. The operational UV dose shall be calculated from UVT and flow.
- b. **Reporting.** The Permittee shall report daily average and lowest daily UVT and operations UV dose on its monthly SMRs. The Permittee shall report daily average and maximum flow through the UV disinfection system. If the UVT falls below 35 percent or UV dose falls below 50 mJ/cm², the event shall be reported to the Regional Water Board by telephone within 24 hours.

B. Visual Monitoring (Monitoring Locations EFF-001, EFF-003, and RSW-001)

1. Visual observations of the discharge and the receiving water shall be recorded monthly and on the first day of each intermittent discharge. Visual monitoring shall include, but not be limited to, observations for floating materials, coloration, objectionable aquatic growths, oil and grease films, and odors. Visual observations and immediate actions taken necessary to clean up shall be recorded and included in the Permittee's quarterly SMRs.

C. Biosolids Monitoring

1. Biosolids monitoring shall be conducted as required by the *Biosolids General Order No. 2004-0012-DWQ*.

X. REPORTING REQUIREMENTS

A. General Monitoring and Reporting Requirements

1. The Permittee shall comply with all Standard Provisions (Attachment D) related to monitoring, reporting, and recordkeeping.

B. Self-Monitoring Reports (SMRs)

1. The Permittee shall submit electronic Self-Monitoring Reports (eSMRs) using the State Water Board's California Integrated Water Quality System (CIWQS) Program Web site (<http://www.waterboards.ca.gov/ciwqs/index.html>). The CIWQS Web site will provide additional directions for SMR submittal in the event there will be service interruption for electronic submittal. The Permittee shall maintain sufficient staffing and resources to ensure it submits eSMRs that are complete and timely. This includes provision of training and supervision of individuals (e.g., Permittee personnel or consultant) on how to prepare and submit eSMRs.
2. The Permittee shall report in the SMR the results for all monitoring specified in this MRP under sections III through IX. The Permittee shall submit quarterly SMRs including the results of all required monitoring using U.S. EPA approved test methods or other test methods specified in this Order. SMRs are to include all new monitoring results obtained since the last SMR was submitted. If the Permittee monitors any pollutant more frequently than required by this Order, the results of this monitoring shall be included in the calculations and reporting of the data submitted in the SMR.

¹ These Disinfection Requirements will take effect upon activation of Phase Two of the Proposed Treatment Upgrade

3. All monitoring results reported shall be supported by the inclusion of the complete analytical report from the laboratory that conducted the analyses.
4. Monitoring periods and reporting for all required monitoring shall be completed according to the following schedule:

Table E-7. Monitoring Periods and Reporting Schedule

Sampling Frequency	Monitoring Period Begins On...	Monitoring Period	SMR Due Date
Continuous	Permit effective date	(Midnight through 11:59 PM) or any 24-hour period that reasonably represents a calendar day for purposes of sampling.	First day of second calendar month following the end of each quarter ¹ (February 1, May 1, August 1, November 1)
Daily	Permit effective date	(Midnight through 11:59 PM) or any 24-hour period that reasonably represents a calendar day for purposes of sampling	First day of second calendar month following the end of each quarter ¹ (February 1, May 1, August 1, November 1)
Weekly	Sunday following permit effective date or on permit effective date if on a Sunday	Sunday through Saturday	First day of second calendar month following the end of each quarter ¹ (February 1, May 1, August 1, November 1)
Monthly	First day of calendar month following permit effective date or on permit effective date if that date is first day of the month	First day of calendar month through last day of calendar month	First day of second calendar month following the end of each quarter ¹ (February 1, May 1, August 1, November 1)
Quarterly	Closest of January 1, April 1, July 1, or October 1 following (or on) permit effective date	January through March April through June July through September October through January	First day of second calendar month following the end of each quarter ¹ (February 1, May 1, August 1, November 1)
Annually	January 1 following (or on) permit effective date	January 1 through December 31	March 1, each year (with annual report)
Twice per permit term	Permit effective date	All	March 1 following the year that monitoring is completed (with annual report) and at least 180 days prior to permit expiration
Table Notes:			
1. Quarterly monitoring periods are as follows: January 1 through March 31; April 1 through June 30; July 1 through September 30; and October 1 through December 31.			

5. **Reporting Protocols.** The Permittee shall report with each sample result the applicable ML, the RL, and the current Method Detection Limit (MDL), as determined by the procedure in 40 C.F.R. part 136.

The Permittee shall report the results of analytical determinations for the presence of chemical constituents in a sample using the following reporting protocols:

- a. Sample results greater than or equal to the reported ML shall be reported as measured by the laboratory (i.e., the measured chemical concentration in the sample).
- b. Sample results less than the reported ML, but greater than or equal to the laboratory's MDL, shall be reported as "Detected, but Not Quantified," or DNQ. The estimated chemical concentration of the sample shall also be reported.

For the purposes of data collection, the laboratory shall write the estimated chemical concentration next to DNQ as well as the words "Estimated Concentration" (may be shortened to "Est. Conc."). The laboratory may, if such information is available, include numerical estimates of the data quality for the reported result. Numerical estimates of data quality may be percent accuracy (\pm a percentage of the reported value), numerical ranges (low to high), or any other means considered appropriate by the laboratory.

- c. Sample results less than the laboratory's MDL shall be reported as "Not Detected," or ND.
 - d. The Permittee is to instruct laboratories to establish calibration standards so that the ML value (or its equivalent if there is differential treatment of samples relative to calibration standards) is the lowest calibration standard. At no time is the Permittee to use analytical data derived from extrapolation beyond the lowest point of the calibration curve.
6. The Permittee shall submit SMRs in accordance with the following requirements:
- a. The Permittee shall arrange all reported data in a tabular format. The data shall be summarized to clearly illustrate whether the Facility is operating in compliance with interim and/or final effluent limitations. The reported data shall include calculation of all effluent limitations that require averaging, taking of a median, or other computation. The Permittee is not required to duplicate the submittal of data that is entered in a tabular format within CIWQS. When electronic submittal of data is required and CIWQS does not provide for entry into a tabular format within the system, the Permittee shall electronically submit the data in a tabular format as an attachment.
 - b. The Permittee shall attach a cover letter to the SMR. The information contained in the cover letter shall clearly identify:
 - i. Facility name and address;
 - ii. WDID number;
 - iii. Applicable period of monitoring and reporting;
 - iv. Violations of the WDRs (identified violations must include a description of the requirement that was violated and a description of the violation);
 - v. Corrective actions taken or planned; and
 - vi. The proposed time schedule for corrective actions.
 - c. SMRs must be submitted to the Regional Water Board, signed and certified as required by the Standard Provisions (Attachment D), to the CIWQS Program Web site (<http://www.waterboards.ca.gov/ciwqs/index.html>). In the event that an alternate method for submittal of SMRs is required, the Permittee shall submit the SMR electronically via e-mail to NorthCoast@waterboards.ca.gov or on disk (CD or DVD) in Portable Document Format (PDF) file in lieu of paper-sourced documents. The guidelines for electronic submittal of documents can be found on the Regional Water Board website at <http://waterboards.ca.gov/northcoast>.

C. Discharge Monitoring Reports (DMRs)

- DMRs are U.S. EPA reporting requirements. The Permittee shall electronically certify and submit DMRs together with SMRs using Electronic Self-Monitoring Reports module eSMR 2.5 or any upgraded version. DMRs shall be submitted quarterly on the first day of the second calendar month following the end of each quarter (February 1, May 1, August 1, and November 1). Electronic DMR submittal shall be in addition to electronic SMR submittal. Information regarding electronic DMR submittal is available at the DMR website at http://www.waterboards.ca.gov/water_issues/programs/discharge_monitoring/.

D. Other Reports

- Special Study Reports and Progress Reports.** As specified in the Special Provisions contained in section VI of the Order, special study and progress reports shall be submitted in accordance with the following reporting requirements.

Table E-8. Reporting Requirements for Special Provisions Reports

Order Section	Special Provision Requirement	Reporting Requirements
Special Provision VI.C.2.a	AMWS Evaluation Report	Submit with Report of Waste Discharge
Special Provision VI.C.2.b	Disaster Preparedness Assessment Report and Action Plan	June 1, 2022
Special Provision VI.C.2.c	Source Control and Pretreatment Studies	December 31, 2023
Special Provision VI.C.3.a.ii(e)	Pollutant Minimization Program, Annual Facility Report	March 1 , annually, following development of Pollutant Minimization Program
Special Provision VI.C.5.f	Adequate Capacity, Technical Report	Within 120 days of notification that the Facility will reach capacity within 4 years
MRP General Monitoring Provision I.F	DMR-QA Study Report	Annually , per State Water Board instructions
MRP WET Testing Requirement V.B.9.b	Notification of TRE/TIE Results	No later than 30 days from the completion of each aspect of the TRE/TIE analyses.
MRP WET Testing Requirement V.B.9.b	TRE/TIE Results	Within 60 days of completion of TRE/TIE analyses
MRP WET Testing Requirement V.C.2	Detailed TRE Work Plan	Within 30 days of an accelerated monitoring test that results in "Fail"
MRP Reporting Requirements X.D.2	Annual Report	March 1 , each year
MRP Reporting Requirements X.D.3	Annual Pretreatment Report	March 1 , each year
MPR Reporting Requirement X.E	Notification of spills and unauthorized discharges	Oral reporting within 24 hours and written report within 5 days

- Annual Report.** The Permittee shall submit an annual report to the Regional Water Board for each calendar year through the CIWQS Program Web site (<http://www.waterboards.ca.gov/ciwqs/index.html>). In the event that an alternate method for submittal of the annual report is required, the Permittee shall submit the annual report electronically via the email address in section X.B.6.c., above. The report shall be submitted

by **March 1st** of the following year and certified as required by Standard Provisions (Attachment D) of this Order. The report shall, at a minimum, include the following:

- a. Where appropriate, tabular and/or graphical summaries of the monitoring data and disposal records from the previous year. If the Permittee monitors any pollutant more frequently than required by this Order, using test procedures approved under 40 C.F.R. part 136 or as specified in this Order, the results of this monitoring shall be included in the calculation and report of the data submitted in the SMR.
 - b. A comprehensive discussion of the Facility's compliance (or lack thereof) with all effluent limitations and other WDRs, and the corrective actions taken or planned, which may be needed to bring the discharge into full compliance with the Order.
 - c. The titles and general responsibilities of all persons employed at the Facility;
 - d. The names and telephone numbers of persons to contact regarding the Facility for emergency and routine situations; and
 - e. A statement certifying when the flow meter(s) and other monitoring instruments and devices were last calibrated, including identification of who performed the calibration.
 - f. **Sludge Handling and Disposal Activity Reporting.** The Permittee shall submit, as part of its annual report to the Regional Water Board, the most recent annual report from *Biosolids General Order No. 2004-0012 DWQ*.
 - g. **Storm Water Reporting.** The Permittee shall submit, as part of its annual report to the Regional Water Board, an evaluation of the effectiveness of the Permittee's best management practices (BMPs) to control the run-on of storm water to the treatment facility site, as well as activities to maintain and upgrade these BMPs.
3. **Annual Pretreatment Reporting Requirements.** The Permittee shall submit annually a report to the Regional Water Board, with copies to U.S. EPA Region 9 and the State Water Board, describing the Permittee's pretreatment activities over the previous calendar year. In the event that the Permittee is not in compliance with any conditions or requirements of this Order, including noncompliance with pretreatment audit/compliance inspection requirements, then the Permittee shall also include the reasons for noncompliance and state how and when the Permittee shall comply with such conditions and requirements.

An annual report shall be submitted by March 1st of the following year, and include at least the following items:

- a. A summary of analytical results from all influent, effluent, and sludge sampling conducted during the reporting period, as specified in sections III.A (Table E-2), IV.A (Table E-3), IV.B (Table E-4), IV.C (Table E-5), and IX.C of the MRP. The Permittee shall also report results of any influent, effluent, or sludge monitoring data for nonpriority pollutant that may be causing or contributing to interference, pass-through, or adversely impacting sludge quality.
- b. A discussion of upset, interference, or pass-through incidents, if any, at the treatment plant, which the Permittee knows, or suspects were caused by industrial users of the POTW or receipt of septage or other incompatible wastes. The discussion shall include the reasons why the incidents occurred, the corrective actions taken and, if known, the name and address of, the industrial user(s) responsible. The discussion shall also include a review of the applicable pollutant limitations to determine whether any additional limitations, or changes to existing requirements, may be necessary to prevent pass-through, interference, or noncompliance with sludge disposal requirements.

- c.** The cumulative number of industrial users that the Permittee has notified regarding Baseline Monitoring Reports and the cumulative number of industrial user responses.
- d.** An updated list of the Permittee's industrial users including their names and addresses, or a list of deletions and additions keyed to a previously submitted list. The Permittee shall provide a brief explanation for each deletion. The list shall identify the industrial users subject to federal categorical standards by specifying which set(s) of standards are applicable. The list shall indicate which categorical industries, or specific pollutants from each industry, are subject to local limitations that are more stringent than the federal categorical standards. The Permittee shall also list the non-categorical industrial users that are subject only to local discharge limitations.
- e.** The Permittee shall characterize the compliance status through the year of record of each industrial user by employing the following descriptions:
 - i.** Compiled with baseline monitoring report requirements (where applicable);
 - ii.** Consistently achieved compliance;
 - iii.** Inconsistently achieved compliance;
 - iv.** Significantly violated applicable pretreatment requirements as defined by 40 C.F.R. section 403.8(f)(2)(vii);
 - v.** Compiled with schedule to achieve compliance (include the date final compliance is required);
 - vi.** Did not achieve compliance and not on a compliance schedule; and
 - vii.** Compliance status unknown.
- f.** A summary of the inspection and sampling activities conducted by the Permittee during the past year to gather information and data regarding the industrial users. The summary shall include:
 - i.** The names and addresses of the industrial users subjected to surveillance and an explanation of whether they were inspected, sampled, or both and the frequency of these activities at each user; and
 - ii.** The conclusions or results from the inspection or sampling of each industrial user.
- g.** A summary of the compliance and enforcement activities during the past year. The summary shall include the names and addresses of the industrial users affected by the following actions:
 - i.** Warning letters or notices of violation regarding the industrial users' apparent noncompliance with federal categorical standards or local discharge limitations. For each industrial user, identify whether the apparent violation concerned the federal categorical standards or local discharge limitations.
 - ii.** Administrative orders regarding the industrial users' noncompliance with federal categorical standards or local discharge limitations. For each industrial user, identify whether the violation concerned the federal categorical standards or local discharge limitations.
 - iii.** Civil actions regarding the industrial users' noncompliance with federal categorical standards or local discharge limitations. For each industrial user, identify whether the violation concerned the federal categorical standards or local discharge limitations.

- iv. Criminal actions regarding the industrial users' noncompliance with federal categorical standards or local discharge limitations. For each industrial user, identify whether the violation concerned the federal categorical standards or local discharge limitations.
- v. Assessment of monetary penalties. For each industrial user identify the amount of the penalties.
- vi. Restriction of flow to the POTW.
- vii. Disconnection from discharge to the POTW.
- h. A description of any significant changes in operating the pretreatment program which differ from the information in the Permittee's approved Pretreatment Program including, but not limited to, changes concerning: the program's administrative structure, local industrial discharge limitations, monitoring program or monitoring frequencies, legal authority or enforcement policy, funding mechanisms, resource requirements, or staffing levels.
- i. A summary of the annual pretreatment budget, including the cost of pretreatment program functions and equipment purchases.
- j. A summary of public participation activities to involve and inform the public.
- k. A brief description of any programs the POTW implements to reduce pollutants from nondomestic users that are not classified as significant industrial users (SIUs).
- l. In the event that the Permittee is not in compliance with any conditions or requirements of this permit affected by the pretreatment program, including any noncompliance with pretreatment audit or compliance inspection requirements, then the Permittee shall also include the reasons for noncompliance and state how and when the Permittee will comply with such conditions and requirements.

Duplicate signed copies of these Pretreatment Program reports shall be submitted to the North Coast Regional Water Board at NorthCoast@waterboards.ca.gov, U.S. EPA Region 9 at R9Pretreatment@epa.gov, and the State Water Board at the appropriate address below:

Standard Mail	FEDEX/UPS/Other Private Carriers
State Water Resources Control Board Division of Water Quality c/o discharge Monitoring Report Processing Center Post Office Box 100 Sacramento, CA 95812-1000	State Water Resources Control Board Division of Water Quality c/o DMR Processing Center 1001 I Street, 15 th Floor Sacramento, CA 95814

E. Spill Notification

- 1. **Spills and Unauthorized Discharges.** Information regarding all spills and unauthorized discharges (except SSOs) that may endanger health or the environment shall be provided orally to the Regional Water Board¹ within 24 hours from the time the Permittee becomes aware of the circumstances and a written report shall also be provided within five (5) days of the time the Permittee becomes aware of the circumstances, in accordance with section V.E of Attachment D.

¹ The contact number of the Regional Water Board during normal business hours is (707) 576-2220. After normal business hours, spill reporting to the California Governor's Office of Emergency Services Warning Center (CalOES) will satisfy the 24 hour spill reporting requirement for the Regional Water Board. The contact number for spill reporting for the CalOES is (800) 852-7550.

Information to be provided verbally to the Regional Water Board includes:

- a. Name and contact information of caller;
 - b. Date, time, and location of spill occurrence;
 - c. Estimates of spill volume, rate of flow, and spill duration, if available and reasonably accurate;
 - d. Surface water bodies impacted, if any;
 - e. Cause of spill, if known at the time of the notification;
 - f. Cleanup actions taken or repairs made at the time of the notification; and
 - g. Responding agencies.
2. **Sanitary Sewer Overflows (SSOs).** Notification and reporting of SSOs is conducted in accordance with the requirements of Order No. 2006-0003-DWQ (Statewide General WDRs for Sanitary Sewer Systems), which is not incorporated herein by reference, and any revisions thereto.

ATTACHMENT F – FACT SHEET

Contents

I.	Permit Information.....	F-3
II.	Facility Description	F-4
	A. Background	F-4
	B. Description of Wastewater and Biosolids Treatment and Controls.....	F-5
	C. Discharge Points and Receiving Waters.....	F-7
	D. Summary of Existing Requirements and Self-Monitoring Report (SMR) Data	F-7
	E. Compliance Summary	F-9
	F. Planned Changes	F-10
III.	Applicable Plans, Policies, and Regulations	F-10
	A. Legal Authorities	F-10
	B. California Environmental Quality Act (CEQA)	F-10
	C. State and Federal Laws, Regulations, Policies, and Plans	F-10
	D. Impaired Water Bodies on the CWA section 303(d) List	F-13
	E. Other Plans, Policies and Regulations	F-14
IV.	Rationale for Effluent Limitations and Discharge Specifications.....	F-14
	A. Discharge Prohibitions	F-15
	B. Technology-Based Effluent Limitations	F-17
	C. Water Quality-Based Effluent Limitations (WQBELs).....	F-21
	D. Final Effluent Limitation Considerations.....	F-38
	E. Interim Effluent Limitations – Not Applicable.....	F-41
	F. Land Discharge Specifications and Requirements – Not Applicable	F-41
	G. Water Recycling Specifications and Requirements – Not Applicable	F-41
	H. Other Requirements	F-41
V.	Rationale for Receiving Water Limitations	F-42
	A. Surface Water	F-42
	B. Groundwater.....	F-42
VI.	Rationale for Provisions.....	F-42
	A. Standard Provisions.....	F-42
	B. Special Provisions.....	F-43
VII.	Rationale for Monitoring and Reporting Requirements	F-46
	A. Influent Monitoring.....	F-46
	B. Effluent Monitoring.....	F-47
	C. Whole Effluent Toxicity Testing Requirements	F-48
	D. Receiving Water Monitoring	F-49
	E. Other Monitoring Requirements	F-49
VIII.	Public Participation.....	F-50
	A. Notification of Interested Parties.....	F-50
	B. Written Comments	F-50
	C. Public Hearing.....	F-50
	D. Waste Discharge Requirements Petitions	F-51
	E. Information and Copying.....	F-51
	F. Register of Interested Persons.....	F-51
	G. Additional Information.....	F-51

Tables

Table F-1. Facility Information	F-3
Table F-2. Historic Effluent Limitations and Monitoring Data – Discharge Point 001	F-7
Table F-3. Historic Effluent Limitations and Monitoring Data – Discharge Point 002	F-8
Table F-4. Historic Effluent Limitations and Monitoring Data – Discharge Point 003	F-9
Table F-5. Basin Plan Beneficial Uses.....	F-11
Table F-6. Summary of Reasonable Potential Analysis Results	F-29
Table F-7. Determination of Long Term Averages	F-33
Table F-8. Determination of Final WQBELs Based on Aquatic Life Criteria	F-33
Table F-9. Determination of Final WQBELs Based on Human Health Criteria	F-34
Table F-10. Summary of Chronic Toxicity Results.....	F-35
Attachment F-1 – City of Arcata RPA Summary.....	F-52

ATTACHMENT F – FACT SHEET

As described in section I, the Regional Water Board incorporates this Fact Sheet as findings of the Regional Water Board supporting the issuance of this Order. This Fact Sheet includes the legal requirements and technical rationale that serve as the basis for the requirements of this Order.

This Order has been prepared under a standardized format to accommodate a broad range of discharge requirements for dischargers in California. Only those sections or subsections of this Order that are specifically identified as “not applicable” have been determined not to apply to this Permittee. Sections or subsections of this Order not specifically identified as “not applicable” are fully applicable to this Permittee.

I. PERMIT INFORMATION

The following table summarizes administrative information related to the facility.

Table F-1. Facility Information

WDID	1B821140HUM
Permittee	City of Arcata
Name of Facility	Wastewater Treatment Facility
Facility Address	600 South G Street
	Arcata, CA 95521
	Humboldt County
Facility Contact, Title and Phone	Karen Diemer, City Manager, (707) 822-5953
Authorized Person to Sign and Submit Reports	Mark Andre, Director of Environmental Services, (707) 822-5953
Mailing Address	736 F Street, Arcata, CA 95521
Billing Address	Same as Mailing Address
Type of Facility	Publicly Owned Treatment Works (POTW)
Major or Minor Facility	Major
Threat to Water Quality	1
Complexity	A
Pretreatment Program	Yes
Recycling Requirements	Not Applicable
Facility Permitted Flow	2.3 million gallons per day (mgd) (average dry weather flow)
Facility Design Flow	2.3 mgd (average dry weather design flow)
	5.0 mgd (average wet weather design flow)
	5.9 mgd (peak wet weather design flow)
	16.5 mgd (wet weather Q_{max})
Watershed	Eureka Plain Hydrologic Unit
Receiving Water	Humboldt Bay, Arcata Marsh Wildlife Sanctuary (AMWS), and a brackish marsh tributary to Humboldt Bay
Receiving Water Type	Estuarine and Freshwater Wetlands

- A. The City of Arcata (hereinafter Permittee) is the owner and operator of the Arcata Wastewater Treatment Facility (hereinafter Facility), a POTW.

For the purposes of this Order, references to the “discharger” or “permittee” in applicable federal and state laws, regulations, plans, or policy are held to be equivalent to references to the Permittee herein.

The Permittee is authorized to discharge subject to waste discharge requirements (WDRs) in this Order at the discharge locations described in Table 2 on the cover page of this Order. The Code of

Federal Regulations at 40 C.F.R. section 122.46 limits the duration of National Pollutant Discharge Elimination System (NPDES) permits to be effective for a fixed term not to exceed five years. Accordingly, Table 3 of this Order limits the effective period for the discharge authorized by this Order. Pursuant to California Code of Regulations (CCR), title 23, section 2235.4, the terms and conditions of an expired permit are automatically continued pending issuance of a new permit if all requirements of the federal NPDES regulations on continuation of expired permits are complied with.

- B. The Facility discharges treated wastewater to Humboldt Bay, a water of the United States, in conjunction with enhanced treatment occurring in the AMWS constructed freshwater wetlands. The Permittee was previously regulated by Order No. R1-2012-0031 and NPDES Permit No. CA0022713 adopted on June 7, 2012 and expired on July 31, 2017. Attachment B provides a map of the area around the Facility. Attachment C provides a flow schematic of the Facility.
- C. The Permittee filed a report of waste discharge (ROWD) and submitted an application for reissuance of its WDRs and NPDES permit on January 26, 2017. The application was deemed complete on **February 21, 2017**.

II. FACILITY DESCRIPTION

The Permittee owns and operates a municipal wastewater treatment facility (WWTF) and associated collection system. The Facility serves the City of Arcata and the unincorporated community of Glendale. The Facility serves a population of approximately 18,695, including 18,169 within the City of Arcata and 526 within the community of Glendale.

A. Background

Adopted on May 16, 1974, Resolution No. 74-43, known as the Bays and Estuaries Policy, prohibits the discharge of municipal wastewater and industrial process water to enclosed bays and estuaries “*unless the discharge enhances the quality of the receiving water above that which would occur in the absence of the discharge.*”¹ The Enclosed Bays and Estuaries Policy enhancement criteria is defined as, “... (1) *Full uninterrupted protection of all beneficial uses which could be made of the receiving water body in the absence of all point source discharge(s) along with (2) a demonstration by the applicant that the discharge, through the creation of new beneficial uses or fuller realization, enhances water quality for those beneficial uses which could be made of the receiving water in the absence of all point source discharges...*”²

In the fall of 1974, the Permittee first began to pursue an exemption from the Enclosed Bays and Estuaries Policy, and in the spring of 1977, the Permittee brought forward a project consisting of a marsh treatment process with discharge to Humboldt Bay.³

In 1979, after holding a fact-finding hearing, the State Water Resources Control Board (State Water Board) issued Order No. 79-20, interpreting the provision of the Enclosed Bays and Estuaries Policy that provided for an exemption from the discharge of municipal wastewater into an enclosed bay, such as Humboldt Bay. In that decision, the State Water Board concluded that there was a reasonable probability that the discharge of secondary, disinfected and dechlorinated effluent into Humboldt Bay, together with a treatment process which either created new beneficial uses or resulted in a fuller realization of existing beneficial uses, such as the marsh treatment process proposed by the Permittee, could enhance the receiving water quality. The State Water Board further concluded that enhancement required: (1) full secondary treatment,

¹ State Water Resources Control Board, Water Quality Control Policy For The Enclosed Bays and Estuaries of California, May 1974

² State Water Resources Control Board, Bill Dendy Memorandum to Regional Water Board Executive Officer David Joseph, October 21, 1974

³ City of Arcata, draft Wastewater Treatment, Water Reclamation, and Ocean Ranching, April 18, 1977

with disinfection and dechlorination, of sewage discharges; (2) compliance with any additional NPDES permit requirements issued by the Regional Water Board to protect beneficial uses; and (3) the fuller realization of existing beneficial uses or the creation of new beneficial uses either by or in conjunction with a wastewater treatment project.¹ A pilot project funded by the State Water Board in 1981 was designed and implemented by the Permittee to demonstrate the effectiveness of wetland treatment in meeting water quality treatment standards. The final report from this pilot was accepted by the Regional Water Board.²³

In 1983, the Regional Water Board adopted Resolution No. 83-9, granting the Permittee a waiver, as defined in Chapter I, Paragraph A of the Enclosed Bays and Estuaries Policy, permitting continued Humboldt Bay discharge. Resolution No. 83-9 found that the marsh disposal alternative meets the definition of enhancement set forth in State Water Board Order No. 79-20 because the waste would achieve secondary treatment standards, create no adverse impacts to present beneficial uses and the discharge would create new beneficial uses and wildlife habitat.⁴

As constructed, the AMWS consists of three freshwater wetlands: Allen, Gearheart, and Hauser Marshes. These marshes currently receive equivalent to secondary treated wastewater, provide enhanced treatment for discharges to Humboldt Bay, and create new beneficial uses, which would not exist in the absence of the discharge. The AMWS provides enhanced water quality treatment, while hosting a variety of cold-water aquatic organisms and vegetation, creating an extraordinary habitat for shorebirds, waterfowl, raptors, and migratory birds. As a result, the AMWS is an integral part of the WWTF and a valued part of the Arcata community as it provides numerous non-contact recreation and educational opportunities.

B. Description of Wastewater and Biosolids Treatment and Controls

1. Existing Treatment Configuration. Primary wastewater treatment consists of mechanical bar screens, grit removal, and two primary clarifiers. Primary solids are sent to two anaerobic digesters, sludge drying beds, and a sludge composting operation. Influent flows above 5.0 mgd are diverted around primary treatment directly to the oxidation ponds.

Secondary treatment is accomplished using two oxidation ponds 22.4 acres and 17.3 acres in size, respectively, and six treatment marshes. Detention time in the Facility, prior to enhanced treatment in the AMWS, is approximately 39 days during average dry weather design flow periods. Effluent is disinfected with chlorine and dechlorinated with sulfur dioxide prior to discharge. Treated effluent is continuously commingled with effluent from the AMWS, disinfected, and split, flowing by gravity either to Humboldt Bay or again through the AMWS. The result is disinfected secondary effluent, but not all effluent receives the benefit of enhanced treatment through the AMWS before discharge to Humboldt Bay and some effluent may be chlorinated multiple times, increasing the opportunity to form disinfection byproducts above water quality objectives. The average flow through the AMWS during the previous permit (August 2012 through April 2019) was 1.14 mgd with a maximum flow of 2.3 mgd.

2. Upgraded Treatment Configuration. The Permittee is planning to upgrade the Facility in two phases. Phase One of the Proposed Upgrade Project will consist of rehabilitation of the headworks and primary clarifier, new aerators in oxidation pond one, addition of a baffle

¹ State Water Board Order No. 79-20, May 17, 1979

² Gearhart, R.A., B. Finney, S. Wilbur, J. Williams, D. Hill, and S. Sundberg, City of Arcata Marsh Pilot Project, Effluent Quality Results System Design Management, Project No: C-06-2270, State of California Water Resources Control Board, Sacramento, CA, 1983.

³ Gearhart, R.A., S. Wilbur, H. Holbrook, and M. Ives, City of Arcata Marsh and Pilot Project, Wetland Bacteria Speciation and Harvesting Effect on Water Quality, Project No: 3-154-500-0, State of California Water Resources Control Board, Sacramento, CA, 1983.

⁴ Regional Water Board, Resolution No. 83-9, July 28, 1983

wall and aerators in oxidation pond two, improvements to multiple pump stations, construction of the UV disinfection system and the construction of piping for Discharge Point 003. Completion of this phase will allow for peak flows to be discharged to Discharge Point 003.

Phase Two of the project will include construction of the oxidation ditch, secondary clarifiers, return activated sludge pump station, an alkalinity feed station and rehabilitation of the anaerobic digester. The rehabilitation of the anaerobic digester will include digester cleaning, replacing digester covers, replacing the boiler/heat exchanger, replacing the mixing and heating piping in the primary digester as needed, adding a sludge thickening system and relocating composting facilities to a new area on site. Completion of this phase will allow the Permittee to comply with final effluent limitations for ammonia at Discharge Point 001 and Discharge Point 003 as well as more stringent BOD and TSS limitations at Discharge Point 002. Time Schedule Order No. R1-2019-0011 includes task and compliance dates for completion of Phase One and Phase Two of the Proposed Upgrade Project.

The wetland treatment system train and parallel oxidation ditch train will each treat a portion of the influent flow at variable percentages. The wetland treatment system will treat the majority of the influent flow up to 2.3 mgd. The parallel oxidation ditch treatment train will provide BOD₅ removal and year-round full nitrification treatment capacity to handle the remainder of the hydraulic capacity needs up to 5.9 mgd.

The Permittee is planning to replace the chlorine disinfection system with an ultraviolet light (UV) disinfection system, through which commingled effluent from the treatment wetlands and parallel oxidation ditch will flow prior to discharge to the AMWS at Discharge Point 002. The Permittee has evaluated the ability to disinfect all flow using UV and is currently planning to disinfect flows up to 7.6 mgd through the Facility with UV. Wastewater discharged at Discharge Point 002 will flow through the Allen, Gearheart, and Hauser marshes in succession. The Permittee will manage flows through Allen, Gearheart, and Hauser Marshes to preserve enhanced treatment and beneficial uses of the enhancement marshes. Flow rates determined to negatively impact the enhancement marshes and flow in excess of 5.9 mgd will be diverted around the enhancement marshes. Diverted flow will commingle with Hauser Marsh effluent prior to discharge to the Brackish Marsh at Discharge Point 003. At the design average dry weather flow, detention time in the AMWS is approximately 60 days and results in full secondary treated effluent. Effluent from the AMWS will be discharged to the brackish marsh at Discharge Point 003. Key components of enhanced treatment provided by the AMWS include settling and clarification. The Regional Water Board finds the proposed upgraded treatment configuration is consistent with Resolution Nos. 79-20 and 83-9.

The upgraded Facility configuration will provide overall improvements to effluent quality discharged to Humboldt Bay because all effluent up to 5.9 mgd may receive enhanced treatment through the AMWS. In addition, chlorination will no longer be the primary form of disinfection, so formation of disinfection byproducts will be greatly diminished. Treated effluent discharged at Discharge Point 003 will enter Humboldt Bay in a diffuse manner due to the tidal mixing within the brackish marsh and subsequent flow through tidal marshes. As a result, the upgraded Facility will provide for higher quality effluent entering Humboldt Bay.

Discharge Prohibition III.I prohibits the discharge of treated effluent at Discharge Point 001, other than the portion of flow exceeding 5.9 mgd. For emergency discharges of flows exceeding 5.9 mgd, the Permittee will utilize the chlorine disinfection system to meet disinfection requirements prior to discharge to Humboldt Bay at Discharge Point 001. The

Permittee has evaluated the ability to disinfect all flows using UV but would like to maintain the ability to use chlorine as an emergency disinfection process.

C. Discharge Points and Receiving Waters

1. The Facility is located within the Eureka Plain Hydrologic Unit.
2. For routine discharges of flows prior to completion of Phase One of the Proposed Upgrade Project, effluent treated in accordance with permit requirements in section IV.A.1. of the Order may be discharged to Humboldt Bay. For emergency discharges of flows exceeding 5.9 mgd, after completion of Phase One of the Proposed Upgrade Project, effluent treated in accordance with permit requirements in section IV.B.1 of the Order may be discharged to Humboldt Bay, a water of the United States, from Discharge Point 001 at 40° 51' 18" N latitude and 124° 5' 26" W longitude. Humboldt Bay is an estuarine waterbody.
3. Effluent treated in accordance with permit requirements in section IV.D.1 (prior to completion of Phase Two) and IV.C.1. (after completion of Phase Two) of the Order may be discharged to the AWMS, a water of the state, from Discharge Point 002 at 40° 51' 29" N latitude and 124° 5' 31" W longitude. The AMWS is a freshwater marsh system.
4. Effluent treated in accordance with permit requirements in section IV.B.2. (after completion of Phase One) and IV.C.2. (after completion of Phase Two) of the Order may be discharged to the brackish marsh, a water of the United States, from Discharge Point 003 at 40° 51' 40" N latitude and 124° 5' 37" W longitude. The brackish marsh discharges into a slough within the north end of the Arcata Bay portion of Humboldt Bay.

D. Summary of Existing Requirements and Self-Monitoring Report (SMR) Data

Effluent limitations contained in Order No. R1-2012-0031 for discharges from Discharge Points 001,002 and 003 are as follows. Tables F-2 and F-3 summarize representative monitoring data from the term of Order No. R1-2012-0031 at Monitoring Locations EFF-001 and EFF-002, respectively. The Permittee did not discharge at Discharge Point 003 during the term of Order No. R1-2012-0031; therefore, effluent monitoring data is not available.

Table F-2. Historic Effluent Limitations and Monitoring Data – Discharge Point 001

Parameter	Units	Effluent Limitation			Monitoring Data (August 2012 - January 2017)		
		Average Monthly	Average Weekly	Maximum Daily	Highest Average Monthly Discharge	Highest Average Weekly Discharge	Highest Daily Discharge
Biochemical Oxygen Demand 5-day @ 20°C (BOD ₅)	mg/L	30 ¹	45 ¹	--	32	47	--
	mg/L	45 ²	65 ²	--	--	--	--
	lbs/day	575 ^{1,3}	863 ^{1,3}	--	798	1,349	--
	lbs/day	863 ^{2,3}	1,304 ^{2,3}	--	--	--	--
	% Removal	85 ¹	--	--	74 ⁴	--	--
	% Removal	65 ²	--	--	--	--	--
Fecal Coliform	MPN/100 mL	14 ⁵	--	43 ⁶	--	--	7.8

Parameter	Units	Effluent Limitation			Monitoring Data (August 2012 - January 2017)		
		Average Monthly	Average Weekly	Maximum Daily	Highest Average Monthly Discharge	Highest Average Weekly Discharge	Highest Daily Discharge
pH	standard units	--	--	6.0 – 9.0 ⁷	--	--	5.9 – 7.3
Total Suspended Solids (TSS)	mg/L	30 ¹	45 ¹	--	37.6	61	--
	mg/L	66 ²	95 ²	--	--	--	--
	lbs/day	575 ^{1,3}	863 ^{1,3}	--	1,211	2,200	--
	lbs/day	1,266 ^{2,3}	1,822 ^{2,3}	--	--	--	--
	% Removal	85 ¹	--	--	75.2 ⁴	--	--
	% Removal	65 ²	--	--	--	--	--
Bis(2-Ethylhexyl)Phthalate	µg/L	1.8	--	3.6	2.8	--	2.8
Carbon Tetrachloride	µg/L	0.25	--	0.50	0.80	--	0.80
Cyanide, Total (as CN)	µg/L	0.5	--	1.0	7.0	--	7.0
Dichlorobromomethane	µg/L	0.56	--	1.12	5.7	--	5.7
TCDD-Equivalents	µg/L	1.3 x 10 ⁻⁸	--	2.6 x 10 ⁻⁸	2.9 x 10 ⁻⁷	--	2.9 x 10 ⁻⁷
Chlorine, Total Residual	mg/L	0.01	--	0.02	0.0761	--	2.36
Settleable Solids	ml/L	0.1	--	0.2	0.0193	--	0.4
Acute Toxicity	% Survival	--	--	70 ⁸ /90 ⁹	--	--	70 ¹⁰

Table Notes:

- Interim effluent limitation effective until the activation of the upgraded Facility configuration.
- Final effluent limitation effective upon activation of the upgraded Facility configuration.
- Mass-based effluent limitations are based on the dry weather design flow of the Facility of 2.3 mgd. During wet weather periods, when influent flow exceeds the dry weather design flow rate, mass emission limitations shall be calculated using the concentration-based effluent limitations and the actual daily average effluent flow rate (not to exceed the average wet weather design flow rate of 5.0 mgd).
- Represents the minimum observed percent removal.
- The median concentration shall not exceed a Most Probable Number (MPN) of 14 organisms per 100 mL in a calendar month.
- Not more than 10 percent of samples collected in a calendar month shall exceed 43 MPN/100 mL.
- Applied as instantaneous minimum and instantaneous maximum effluent limitations.
- Minimum for one bioassay.
- Median for any three or more consecutive bioassays.
- Represents the minimum observed percent survival.

Table F-3. Historic Effluent Limitations and Monitoring Data – Discharge Point 002

Parameter	Units	Effluent Limitation			Monitoring Data (August 2012 - January 2017)		
		Average Monthly	Average Weekly	Maximum Daily	Highest Average Monthly Discharge	Highest Average Weekly Discharge	Highest Daily Discharge
Biochemical Oxygen Demand 5-day @ 20°C (BOD ₅)	mg/L	45	65	--	88	140	--
pH	standard units	--	--	6.0 – 9.0 ¹	--	--	6.1 – 7.3
Total Suspended Solids (TSS)	mg/L	66	95	--	44	66	--
Chlorine, Total Residual	mg/L	0.01	--	0.02	0.0761	--	2.36

Parameter	Units	Effluent Limitation			Monitoring Data (August 2012 - January 2017)		
		Average Monthly	Average Weekly	Maximum Daily	Highest Average Monthly Discharge	Highest Average Weekly Discharge	Highest Daily Discharge
Settleable Solids	ml/L	0.1	--	0.2	0.0193	--	0.40

Table Notes:

1. Applied as instantaneous minimum and instantaneous maximum effluent limitations.

Table F-4. Historic Effluent Limitations and Monitoring Data – Discharge Point 003

Parameter	Units	Effluent Limitation		
		Average Monthly	Average Weekly	Maximum Daily
Biochemical Oxygen Demand 5-day @ 20°C (BOD ₅)	mg/L	30	45	--
	lbs/day	575 ¹	863 ¹	--
	% Removal	85	--	--
Fecal Coliform	MPN/100 mL	14 ²	--	43 ³
pH	standard units	--	--	6.0 – 9.0 ⁴
Total Suspended Solids (TSS)	mg/L	30	45	--
	lbs/day	575 ¹	863 ¹	--
	% Removal	85	--	--
Bis(2-Ethylhexyl)Phthalate	µg/L	1.8	--	3.6
Carbon Tetrachloride	µg/L	0.25	--	0.50
Copper, Total Recoverable	µg/L	2.9	--	5.8
Cyanide, Total (as CN)	µg/L	0.5	--	1.0
TCDD-Equivalents	µg/L	1.3 x 10 ⁻⁸	--	2.6 x 10 ⁻⁸
Settleable Solids	ml/L	0.1	--	0.2
Acute Toxicity	% Survival	--	--	70 ⁵ /90 ⁶

Table Notes:

1. Mass-based effluent limitations are based on the dry weather design flow of the Facility of 2.3 mgd. During wet weather periods, when influent flow exceeds the dry weather design flow rate, mass emission limitations shall be calculated using the concentration-based effluent limitations and the actual daily average effluent flow rate (not to exceed the average wet weather design flow rate of 5.0 mgd).
2. The median concentration shall not exceed a Most Probable Number (MPN) of 14 organisms per 100 mL in a calendar month.
3. Not more than 10 percent of samples collected in a calendar month shall exceed 43 MPN/100 mL.
4. Applied as instantaneous minimum and instantaneous maximum effluent limitations.
5. Minimum for one bioassay.
6. Median for any three or more consecutive bioassays.

E. Compliance Summary

On May 24, 2013, the Executive Officer issued Administrative Civil Liability (ACL) Complaint No. R1-2013-0034 for two violations, including failing to submit a ROWD or apply for a 401 Water Quality Certification for a maintenance project in violation of Water Code section 13376 and engaging in project activities that resulted in sediment discharges to Janes Creek, a tributary to Humboldt Bay, from October 2-3, 2012 in violation of Water Code section 13243 and prohibitions and criteria contained in the Basin Plan. The ACL Complaint assessed a penalty of \$10,880 for these violations, including \$1,200 for staff costs. The Permittee agreed to pay the assessed penalty of \$10,880.

From August 1, 2012, through September 30, 2018 the Permittee had 115 effluent limitation violations for the following parameters: dichlorobromomethane (39), pH (3), carbon tetrachloride (2), settleable solids (1), 2,3,7,8-TCDD (2), total cyanide (6), total copper (25), total suspended solids (TSS) concentration (10), TSS mass loading (10), biochemical oxygen demand (BOD) concentration (2), BOD mass loading (2), BOD percent removal (6), TSS percent removal (5) and fecal coliform (1). These effluent limitation violations are currently under review for future enforcements actions.

F. Planned Changes

As discussed in section II.B.2 of this Fact Sheet, the Permittee is planning to construct Facility upgrades to comply with the requirements of this Order. The upgrades will include oxidation pond and wetland treatment system improvements, construction of a parallel oxidation ditch treatment system, construction of a UV disinfection system upstream of discharge to the AMWS, and an updated Facility configuration allowing for discharges from the AMWS to the brackish marsh in order to provide overall improvements to effluent quality discharged to Humboldt Bay.

The Proposed Treatment Upgrade Project will replace the chlorine disinfection system with a UV disinfection system for the peak wet weather design flows of 5.9 mgd, or greater. Emergency flows, in excess of the peak design flows of 5.9 mgd, may be disinfected with chlorine and discharged via Discharge Point 001 or via Discharge Point 003 through the adaptive management diversion line. The Permittee is investigating the possibility of disinfecting all flows with UV and would like to maintain chlorine disinfection as a backup. Eliminating the use of chlorine will reduce the number of violations for dichlorobromomethane, a chlorine disinfection by-product. The oxidation ditch and new clarifiers will provide full secondary treatment for a portion of flow, improve ammonia removal, BOD and TSS removal and likely address toxicity concerns. The new discharge location, Discharge Point 003, will allow the discharge from the Facility to enter Humboldt Bay in a diffuse manner due to the tidal mixing within the brackish marsh and subsequent flow through tidal marshes.

III. APPLICABLE PLANS, POLICIES, AND REGULATIONS

The requirements contained in this Order are based on the requirements and authorities described in this section.

A. Legal Authorities

This Order serves as Waste Discharge Requirements (WDRs) pursuant to article 4, chapter 4, and division 7 of the California Water Code (commencing with section 13260). This Order is also issued pursuant to section 402 of the federal Clean Water Act (CWA) and implementing regulations adopted by the U.S. Environmental Protection Agency (U.S. EPA) and chapter 5.5, division 7 of the Water Code (commencing with section 13370). It shall serve as an NPDES permit authorizing the Permittee to discharge into waters of the United States at the discharge location described in Table 2 subject to the WDRs in this Order.

B. California Environmental Quality Act (CEQA)

Under Water Code section 13389, this action to adopt an NPDES permit is exempt from the provisions of Chapter 3 of CEQA, (commencing with section 21100) of Division 13 of the Public Resources Code.

C. State and Federal Laws, Regulations, Policies, and Plans

- 1. Water Quality Control Plan.** The Regional Water Board adopted a *Water Quality Control Plan for the North Coast Region* (hereinafter Basin Plan) that designates beneficial uses, establishes water quality objectives, and contains implementation programs and policies to achieve those objectives for all waters addressed through the plan.

The Basin Plan designates a beneficial use of municipal and domestic supply (MUN) to Humboldt Bay. In addition, the Basin Plan implements State Water Board Resolution No. 88-63, which establishes state policy that all waters, with certain exceptions, should be considered suitable or potentially suitable for MUN. Salinity in Humboldt Bay in the vicinity of the discharge was reported as high as 51,587 $\mu\text{S}/\text{cm}$, which well exceeds the salinity threshold 5,000 $\mu\text{S}/\text{cm}$ included in Resolution No. 88-63. Therefore, this Order does not apply the MUN designation when considering Humboldt Bay and the brackish marsh in the vicinity of Discharge Points 001 and 003.

The MUN beneficial use has not been designated for the AMWS, as Resolution No. 88-63 exempts “*water in systems designed or modified to collect or treat municipal or industrial wastewaters...provided that the discharge from such systems is monitored to assure compliance with all relevant water quality objectives as required by the Regional Boards.*”

Beneficial uses applicable to Humboldt Bay (an estuarine environment), the AMWS (a freshwater marsh system), and the brackish marsh (an estuarine environment), within the Eureka Plain Hydrologic Unit, are summarized in Table F-5, below:

Table F-5. Basin Plan Beneficial Uses

Discharge Point	Receiving Water Name	Beneficial Use(s)
001 and 003	Humboldt Bay and brackish marsh within the Eureka Plain Hydrologic Unit	<p><u>Existing:</u> Municipal and domestic water supply (MUN) – not applied; Agricultural supply (AGR); Industrial service supply (IND); Freshwater replenishment (FRSH); Navigation (NAV); Water contact recreation (REC-1); Non-contact water recreation (REC-2); Commercial and sport fishing (COMM); Cold freshwater habitat (COLD); Wildlife habitat (WILD); Rare, threatened, or endangered species (RARE); Marine habitat (MAR); Migration of aquatic organisms (MIGR); Spawning, reproduction, and/or early development (SPWN); Shellfish harvesting (SHELL); Estuarine habitat (EST) Aquaculture (AQUA); and Native American culture (CUL).</p> <p><u>Potential:</u> Industrial process supply (PRO); and Hydropower generation (POW).</p>
002	AMWS	<p><u>Existing:</u> Non-contact water recreation (REC-2); Cold freshwater habitat (COLD); Wildlife habitat (WILD); Wetland habitat (WET); and Water quality enhancement (WQE).</p>

Discharge Point	Receiving Water Name	Beneficial Use(s)
--	Groundwater	<u>Existing:</u> Municipal and domestic supply (MUN); Agricultural supply (AGR); Industrial service supply (IND); and Native American Culture (CUL). <u>Potential</u> Industrial Process Supply (PRO); and Aquaculture (AQUA).

Requirements of this Order implement the Basin Plan.

- 2. Enclosed Bays and Estuaries Policy.** The State Water Board adopted State Water Board Resolution No. 74-43, *Water Quality Control Policy for the Enclosed Bays and Estuaries of California* (Enclosed Bays and Estuaries Policy) on May 16, 1974. The State Water Board adopted Resolution No. 95-84 on November 16, 1995, amending the Enclosed Bays and Estuaries Policy. Chapter 1, paragraph A of the Bays and Estuaries Policy requires that the discharge of municipal wastewater to enclosed bays be phased out as early as possible, except when the discharge enhances the quality of the receiving water above that which would occur in the absence of the discharge. As described in section II.A of this Fact Sheet, the Regional Water Board adopted Resolution No. 83-9 on July 28, 1983, to allow the Permittee to discharge to Humboldt Bay in compliance with the Enclosed Bays and Estuaries Policy and State Board Order No. 79-20 and Regional Water Board Resolution No. 83-9.
- 3. Thermal Plan.** The State Water Board adopted a *Water Quality Control Plan for Control of Temperature in the Coastal and Interstate Waters and Enclosed Bays and Estuaries of California* (Thermal Plan) on January 7, 1971 and amended this plan on September 18, 1975. This plan contains temperature objectives for coastal waters. The Permittee does not discharge thermal waste; therefore, the Order does not include effluent limitations for temperature in response to the requirements of the Thermal Plan.
- 4. National Toxics Rule (NTR) and California Toxics Rule (CTR).** U.S. EPA adopted the NTR on December 22, 1992, and later amended it on May 4, 1995 and November 9, 1999. About forty criteria in the NTR applied in California. On May 18, 2000, U.S. EPA adopted the CTR. The CTR promulgated new toxics criteria for California and, in addition, incorporated the previously adopted NTR criteria that were applicable in the state. The CTR was amended on February 13, 2001. These rules contain federal water quality criteria for CTR priority pollutants.
- 5. State Implementation Policy.** On March 2, 2000, the State Water Board adopted the *Policy for Implementation of Toxics Standards for Inland Surface Waters, Enclosed Bays, and Estuaries of California* (State Implementation Policy or SIP). The SIP became effective on April 28, 2000, with respect to the CTR priority pollutant criteria promulgated for California by the U.S. EPA through the NTR and to the CTR priority pollutant objectives established by the Regional Water Board in the Basin Plan. The SIP became effective on May 18, 2000, with respect to the CTR priority pollutant criteria promulgated by the U.S. EPA through the CTR. The State Water Board adopted amendments to the SIP on February 24, 2005, which became effective on July 13, 2005. The SIP establishes implementation provisions for CTR priority pollutant criteria and objectives and provisions for chronic toxicity control.

Section 1.2 of the SIP allows the Regional Water Board to adjust the criteria/objective for metals with discharger-specific Water Effect Ratios (WERS) established in accordance with

U.S. EPA guidance – *Interim Guidance on Determination and Use of Water Effect Ratios for Metals* (EPA-823-B-94-001) or *Streamlined Water-Effect Ratio Procedure for Discharges of Copper* (EPA-822-R-01-005) (Streamlined Procedure). The Streamlined Procedure determines site-specific values for a WER, a criteria adjustment factor accounting for the effect of site-specific water characteristics on pollutant bioavailability and toxicity to aquatic life. Requirements of this Order implement the SIP.

6. **Compliance Schedules and Interim Requirements.** The State Water Board adopted Resolution No. 2008-0025 on April 15, 2008, titled *Policy for Compliance Schedules in National Pollutant Discharge Elimination System Permits*, which includes compliance schedule policies for pollutants that are not addressed by the SIP. This Policy became effective on August 27, 2008.

This Order does not include any compliance schedules or interim effluent limitations.

7. **Antidegradation Policy.** Federal regulation 40 C.F.R. section 131.12 requires that the state water quality standards include an antidegradation policy consistent with the federal policy. The State Water Board established California's antidegradation policy in State Water Board Resolution No. 68-16 (*Statement of Policy with Respect to Maintaining High Quality Waters of California*). Resolution No. 68-16 incorporates the federal antidegradation policy where the federal policy applies under federal law. Resolution No. 68-16 requires that existing water quality be maintained unless degradation is justified based on specific findings. The Regional Water Board's Basin Plan implements, and incorporates by reference, both the state and federal antidegradation policies. The permitted discharge must be consistent with the antidegradation provision of 40 C.F.R. section 131.12 and State Water Board Resolution No. 68-16. As discussed in detail in section IV.D.2 of this Fact Sheet, the permitted discharge is consistent with the antidegradation provision of 40 C.F.R. section 131.12 and State Water Board Resolution No. 68-16.
8. **Anti-Backsliding Requirements.** Sections 402(o)(2) and 303(d)(4) of the CWA and federal regulations at 40 C.F.R. section 122.44(l) restrict backsliding in NPDES permits. These anti-backsliding provisions require that effluent limitations in a reissued permit must be as stringent as those in the previous permit, with some exceptions in which limitations may be relaxed. Some effluent limitations from the previous Order have been removed or are less stringent than those in the previous Order. As discussed in detail in section IV.D.1 of this Fact Sheet, removal or relaxation of effluent limitations is consistent with the anti-backsliding requirements of the CWA and federal regulations.
9. **Endangered Species Act Requirements.** This Order does not authorize an act that results in the taking of a threatened or endangered species or any act that is now prohibited, or becomes prohibited in the future, under either the California Endangered Species Act (Fish and Game Code sections 2050 or 2097) or the Federal Endangered Species Act (16 U.S.C.A sections 1531 to 1544). This Order requires compliance with effluent limits, receiving water limits, and other requirements to protect the beneficial uses of waters of the state, including protecting rare, threatened, and endangered species. The Permittee is responsible for meeting all requirements of the applicable Endangered Species Act.

D. Impaired Water Bodies on the CWA section 303(d) List

Section 303(d) of the federal CWA requires states to identify water bodies that do not meet water quality standards and are not supporting their beneficial uses after implementation of technology-based effluent limitations on point sources. Each state must submit an updated list, the 303(d) List of Impaired Waterbodies, every two years. In addition to identifying the water bodies that are not supporting beneficial uses, the 303(d) list also identifies the pollutant or stressor causing impairment and establishes a schedule for developing a control plan to address

the impairment. The CWA requires development of a total maximum daily load (TMDL) or alternate program of implementation for each 303(d)-listed pollutant and water body to remedy the impairment. TMDLs establish the maximum quantity of a given pollutant that can be added to a water body from all sources without exceeding the applicable water quality standard for that pollutant and determine waste load allocations (the portion of a TMDL allocated to existing and future point sources) and load allocations (the portion of a TMDL attributed to existing and future nonpoint sources).

On April 6, 2018, the U.S. EPA provided final approval of the 2014 and 2016 303(d) List of Impaired Water Bodies prepared by the state. The list identifies Humboldt Bay (Eureka Plain Hydrologic Unit) as impaired by dioxin equivalents and polychlorinated biphenyls (PCBs). Pursuant to CWA section 303(d), the Regional Water Board will develop a TMDL or alternate program of implementation to address these impairments, which will be implemented through various programs, including through provisions of NPDES permits. The Regional Water Board expects to adopt TMDLs for dioxin toxic equivalents and PCBs by 2025. Discharges from the Facility have shown reasonable potential for discharges of dioxin equivalents; therefore, this Order establishes effluent limitations for dioxin equivalents at levels protective of beneficial uses.

E. Other Plans, Policies and Regulations

1. On May 2, 2006, the State Water Board adopted State Water Board Order No. 2006-0003-DWQ, Statewide General WDRs for Sanitary Sewer Systems and on August 6, 2013 adopted Order No. WQ 2013-0058-EXEC Amending Monitoring and Reporting Program for Statewide General Waste Discharge Requirements for Sanitary Sewer Systems. Order No. 2006-0003-DWQ requires that all public agencies that currently own or operate sanitary sewer systems apply for coverage under the General WDRs. The deadline for dischargers to apply for coverage was November 2, 2006. The Permittee applied for coverage and is subject to the requirements of Order Nos. 2006-0003-DWQ and WQ 2013-0058-EXEC and any future revisions thereto for operation of its wastewater collection system.
2. State Water Board Water Quality Order No. 2014-0057-DWQ, NPDES General Permit No. CAS000001, General Permit for Storm Water Discharges Associated with Industrial Activities (Industrial Storm Water General Permit) does not require facilities to obtain coverage if discharges of storm water are regulated under another individual or general NPDES permit adopted by the State Water Board or Regional Water Board (Finding I.B.20). All storm water at the Facility is captured and directed to the Facility headworks for treatment and disposal under this Order. Therefore, coverage under the Industrial Storm Water General Permit is not required for this Facility.

IV. RATIONALE FOR EFFLUENT LIMITATIONS AND DISCHARGE SPECIFICATIONS

The CWA requires point source dischargers to control the amount of conventional, non-conventional, and toxic pollutants that are discharged into the waters of the United States. The control of pollutants discharged is established through effluent limitations and other requirements in NPDES permits. There are two principal bases for effluent limitations in the Code of Federal Regulations: 40 C.F.R. section 122.44(a) requires that permits include applicable technology-based limitations and standards; and 40 C.F.R. section 122.44(d) requires that permits include water quality-based effluent limitations (WQBELs) to attain and maintain applicable numeric and narrative water quality criteria to protect the beneficial uses of the receiving water where a reasonable potential to exceed those criteria exists.

A. Discharge Prohibitions

1. **Discharge Prohibition III.A.** The discharge of waste to Humboldt Bay is prohibited unless the discharge is consistent with State Board Order No. 79-20 and Regional Water Board Resolution No. 83-9.

This prohibition justifies an exception to the Enclosed Bays and Estuaries Policy allowing the continued discharge from the Facility to Humboldt Bay “*only when a discharge enhances the quality of the receiving water above that which would occur in the absence of the discharge.*” Resolution No. 83-9 acknowledged that the discharge of treated wastewater through the AMWS met the definition of “enhancement” as established by State Water Board Order No. WQ 79-20. Discharge Prohibition III.A ensures that this enhancement project will be continued and allows the Regional Water Board to continue to recognize an exception to the Enclosed Bays and Estuaries Policy for the Facility.

2. **Discharge Prohibition III.B.** The discharge of any waste not disclosed by the Permittee or not within the reasonable contemplation of the Regional Water Board is prohibited.

This prohibition is based on the Basin Plan, the previous Order, and State Water Board Order No. WQO 2002-0012 regarding the petition of WDRs Order No. 01-072 for the East Bay Municipal Utility District and Bay Area Clean Water Agencies. In State Water Board Order No WQO 2002-0012, the State Water Board found that this prohibition is acceptable in Orders, but should be interpreted to apply only to constituents that are not disclosed by the Permittee and are not reasonably anticipated to be present in the discharge. It specifically does not apply to constituents in the discharge that do not have “reasonable potential” to exceed water quality objectives.

The State Water Board has stated that the only pollutants not covered by this prohibition are those which were “*disclosed to the permitting authority and...can be reasonably contemplated.*” [In re the Petition of East Bay Municipal Utilities District et al., (State Water Board, 2002) Order No. WQO 2002-0012, p. 24.] In that Order, the State Water Board cited a case that held the Permittee is liable for the discharge of pollutants “*not within the reasonable contemplation of the permitting authority...whether spills or otherwise...*” [*Piney Run Preservation Assn. v. County Commissioners of Carroll County, Maryland* (4th Cir. 2001) 268 F. 3d 255, 268.] Thus, the State Water Board authority provides that, to be permissible, the constituent discharged (1) must have been disclosed by the Permittee and (2) can be reasonably contemplated by the Regional Water Board.

3. **Discharge Prohibition III.C.** Creation of pollution, contamination, or nuisance, as defined by section 13050 of the Water Code is prohibited.

This prohibition has been retained from Order No. R1-2012-0031 and is based on section 13050 of the Water Code and section 5411 of the California Health and Safety Code.

4. **Discharge Prohibition III.D.** The discharge of sludge or digester supernatant is prohibited, except as authorized under section VI.C.5.c of this Order (Sludge Disposal and Handling Requirements).

This prohibition has been retained from Order No. R1-2012-0031 and is based on restrictions on the disposal of sewage sludge found in federal regulations [40 C.F.R. part 503 (Biosolids), part 527, and part 258] and title 27 of the CCR.

5. **Discharge Prohibition III.E.** The discharge of untreated or partially treated waste (receiving a lower level of treatment than described in section II.A of the Fact Sheet) from anywhere within the collection, treatment, or disposal systems is prohibited, except as provided for in Attachment D, Standard Provisions G (Bypass) and H (Upset).

This prohibition has been retained from Order No. R1-2012-0031 and is based on the Basin Plan to protect the beneficial uses of the receiving water from unpermitted discharges, and the intent of the Water Code sections 13260 through 13264 relating to the discharge of waste to waters of the state without filing for and being issued an Order. This prohibition applies to spills not related to sanitary sewer overflows (SSOs) and other unauthorized discharges of wastewater within the collection, treatment, and disposal facilities. The discharge of untreated or partially treated wastewater from the collection, treatment, or disposal facility represents an unauthorized bypass pursuant to 40 C.F.R. section 122.41(m) or an unauthorized discharge, which poses a threat to human health and/or aquatic life, and therefore is explicitly prohibited by this Order.

6. **Discharge Prohibition III.F.** Any SSO that results in a discharge of untreated or partially treated wastewater to (a) waters of the state or (b) land that creates pollution, contamination, or nuisance, as defined in Water Code section 13050(m) is prohibited.

This prohibition is retained from Order No. R1-2012-0031 with a minor modification. A reference to groundwater has been removed because groundwater is captured in the broader term, "waters of the state." This prohibition applies to spills related to SSOs and is based on state standards, including section 13050 of the Water Code and the Basin Plan. This prohibition is consistent with the state's antidegradation policy as specified in State Water Board Resolution No. 68-16 (*Statement of Policy with Respect to Maintaining High Quality of Water in California*) in that the prohibition imposes conditions to prevent impacts to water quality, the degradation of water quality, negative effects on receiving water beneficial uses, and lessening of water quality beyond that prescribed in State Water Board or Regional Water Board plans and policies.

This prohibition is stricter than the prohibitions stated in State Water Board Order No. 2006-0003-DWQ, Statewide General Waste Discharge Requirements for Sanitary Sewer Systems. Order No. 2006-0003-DWQ prohibits SSOs that result in the discharge of untreated or partially treated wastewater to waters of the United States and SSOs that cause a nuisance, compared to Discharge Prohibition III.F of this Order, which prohibits SSO discharges that create nuisance or pollution to waters of the state and land for a more complete protection of human health. The rationale for this prohibition is based on the prevalence of high groundwater quality and shallow groundwater in the North Coast Region, and this Region's reliance on groundwater as a drinking water source.

7. **Discharge Prohibition III.G.** The discharge of waste at any point not described in Finding II.B of the Fact Sheet or authorized by a permit issued by the State Water Board or another Regional Water Board is prohibited.

This prohibition has been retained from Order No. R1-2012-0031. This prohibition is a general prohibition that allows the Permittee to discharge waste only in accordance with WDRs. It is based on sections 301 and 402 of the federal CWA and section 13263 of the Water Code.

8. **Discharge Prohibition III.H.** The average dry weather flow of waste through the Facility shall not exceed 2.3 mgd, measured daily and averaged over a calendar month. Compliance with this prohibition shall be determined as defined in section VII.K of this Order.

This prohibition is retained from Order No. R1-2012-0031 and is based on the permitted flow and design treatment capacity of the Facility. Exceedance of this capacity may result in effluent violations and/or the need to bypass untreated effluent blended with treated effluent, which is prohibited.

9. **Discharge Prohibition III.I.** The discharge of treated effluent at Discharge Point 001 is prohibited other than that portion of the flow exceeding peak flows of 5.9 mgd.

This prohibition is retained from Order No. R1-2012-0031 and is based on Resolution No. 83-9, in which the Regional Water Board acknowledged that the discharge of treated wastewater through the AMWS met the definition of “enhancement” as established by State Water Board Order No. 79-20. Discharge Prohibition III.I ensures that water quality is enhanced by treatment through the AMWS to the fullest extent possible prior to discharge to Humboldt Bay.

Discharge Prohibition III.I shall take effect upon completion of Phase I of the Proposed Upgrade Project which includes construction of Discharge Point 003 to the Brackish Marsh.

- 10. Discharge Prohibition III.J.** The discharge of any radiological, chemical, or biological warfare agent into waters of the state is prohibited under Water Code section 13375.

This prohibition is newly established by this Order and is based on the discharge prohibitions contained in section 13375 of the Water Code.

- 11. Discharge Prohibition III.K.** The acceptance of septage to a location other than an approved septage receiving station is prohibited.

This prohibition is newly established by this Order and is necessary to ensure that septage is not accepted in the absence of a septage management program to ensure that pollutants associated with domestic septage do not pass through or interfere with the operation or performance of the Facility.

B. Technology-Based Effluent Limitations

1. Scope and Authority

Section 301(b) of the CWA and implementing U.S. EPA permit regulations at 40 C.F.R. section 122.44 require that permits include conditions meeting applicable technology-based requirements, at a minimum, and any more stringent effluent limitations necessary to meet applicable water quality standards. The discharge authorized by this Order must meet minimum federal technology-based requirements based on Secondary Treatment Standards at 40 C.F.R. part 133.

Regulations promulgated in 40 C.F.R. section 125.3(a)(1) require technology-based effluent limitations for municipal dischargers to be placed in NPDES permits based on Secondary Treatment Standards or Equivalent to Secondary Treatment Standards.

The Federal Water Pollution Control Act Amendments of 1972 (PL 92-500) established the minimum performance requirements for POTWs [defined in section 304(d)(1)]. Section 301(b)(1)(B) of that Act requires that such treatment works must, as a minimum, meet effluent limitations based on secondary treatment as defined by the U.S. EPA Administrator.

Based on this statutory requirement, U.S. EPA developed secondary treatment regulations, which are specified in 40 C.F.R. part 133. These technology-based regulations apply to all municipal wastewater treatment plants and identify the minimum level of effluent quality attainable by secondary treatment in terms of BOD₅, TSS, and pH, as follows:

a. BOD₅ and TSS

- i.** The 30-day average shall not exceed 30 mg/L.
- ii.** The 7-day average shall not exceed 45 mg/L
- iii.** The 30-day average percent removal shall not be less than 85 percent.

b. pH

The pH shall be maintained within the limits of 6.0 to 9.0.

The effluent limitation for pH required to meet the water quality objective is contained in the Basin Plan, Table 3-1.

In addition, 40 C.F.R. section 122.45(f) requires the establishment of mass-based effluent limitations for all pollutants limited in Orders, except for 1) pH, temperature, radiation, or other pollutants, which cannot be appropriately expressed by mass, 2) when applicable standards and limitations are expressed in terms of other units of measure.

Following publication of the secondary treatment regulations, legislative history indicates that congress was concerned that U.S. EPA had not “sanctioned” the use of certain biological treatment techniques that were effective in achieving significant reductions in BOD₅ and TSS for secondary treatment. Therefore, in order to prevent unnecessary construction of costly new facilities, Congress included language in the 1981 amendment to the Construction Grants statutes [section 23 of Pub. L. 97-147] that required U.S. EPA to provide allowance for alternative biological treatment technologies such as trickling filters or waste stabilization ponds. In response to this requirement, the definition of secondary treatment was modified on September 20, 1984 and June 3, 1985, and published in the revised secondary treatment regulations contained in section 133.105. These regulations allow alternative limitations for facilities using trickling filters and waste stabilization ponds that meet the requirements for “equivalent to secondary treatment.” Equivalent to secondary treatment limitations allow *up to* 45 mg/L (monthly average) and *up to* 65 mg/L (weekly average) for BOD₅ and TSS.

POTWs that use waste stabilization ponds, identified in section 133.103, as the principal process for secondary treatment and whose operation and maintenance data indicate that the TSS values specified in the equivalent to secondary regulations cannot be achieved, can qualify to have their minimum levels of effluent quality for TSS adjusted upwards.

Furthermore, in order to address the variations in facility performance due to geographic, climatic, or seasonal conditions in different states, the Alternative State Requirements (ASR) provision contained in 40 C.F.R. section 133.105(d) was written. ASR allows states the flexibility to set permit limitations above the maximum levels of 45 mg/L (monthly average) and 65 mg/L (weekly average) for TSS from lagoons. However, before ASR limitations for TSS can be set, the effluent must meet the BOD₅ limitations as prescribed by 40 C.F.R. section 133.102(a). Presently, the maximum TSS value set by the State of California for lagoon effluent is 95 mg/L. This value corresponds to a 30-day consecutive average or an average over a duration of less than 30 days.

According to 40 C.F.R. section 125.3(a)(1), in order to be eligible for equivalent to secondary treatment limitations, a POTW must meet all of the following criteria:

- a. The principal treatment process must be either a trickling filter or waste stabilization pond.
- b. The effluent quality consistently achieved, despite proper operations and maintenance, is in excess of 30 mg/L BOD₅ and TSS.
- c. Water quality is not adversely affected by the discharge (section 133.101(g)).
- d. The treatment works as a whole provides significant biological treatment such that a minimum 65 percent reduction of BOD₅ is consistently attained (30-day average).

2. Applicable Technology-Based Effluent Limitations

- a. **Equivalent to Secondary Treatment Standards (BOD₅ and TSS).** In accordance with 40 C.F.R. section 133.101, a facility that utilizes a pond or a trickling filter system and cannot meet the secondary standards after proper operation and maintenance may be

allowed to meet treatment equivalent to secondary limits. As shown in Attachment C, when emergency discharges to Discharge Point 001 will occur (i.e., when flows exceed 5.9 mgd), effluent flows will be diverted from the oxidation ponds (i.e., the waste stabilization ponds), which will be the principle treatment process, to the chlorine contact chambers. Flows exceeding the peak wet weather design flow of 5.9 mgd do not receive enhanced treatment through the AMWS.

40 C.F.R. section 133.105(f) specifies that the permit shall require more stringent effluent limitations for existing facilities that can achieve more stringent limitations through proper operation and maintenance. 40 C.F.R. section 133.101(f) defines effluent concentrations consistently achievable through proper operation and maintenance as “(1) for a given pollutant parameter, the 95th percentile value for the 30-day average effluent quality achieved by a treatment works in a period of at least two years, excluding values attributable to upsets, bypasses, operational errors, or other unusual conditions, and (2) a 7-day average value equal to 1.5 times the value derived under paragraph (f)(1) of this section.” An analysis of monitoring data representative of effluent quality from the oxidation ponds prior to enhanced treatment through the AMWS, collected from August 2012 through April 2019, was performed to determine the 95th percentile value for the 30-day average BOD₅ and TSS concentrations. The 95th percentiles of 30-day averages for BOD₅ and TSS were 38 mg/L and 32 mg/L, respectively.

Effluent concentrations for BOD₅ and TSS that are consistently achievable for the Facility’s waste stabilization pond treatment train, based on the 95th percentile values, exceeded the minimum levels for secondary treated effluent. Therefore, the Permittee is eligible for alternative limits for treatment equivalent to secondary for emergency discharges at Discharge Point 001. This Order establishes average monthly effluent limitations (AMELs) for BOD₅ and TSS of 38 mg/L and 32 mg/L, respectively, with compliance measured at Monitoring Location EFF-001, for emergency discharges to Humboldt Bay. The AMELs for BOD₅ and TSS are based on the 95th percentile values for the 30-day average concentrations, calculated in accordance with 40 C.F.R. section 133.101(f)(1).

Average weekly effluent limitations (AWELs) for BOD₅ and TSS applied at Discharge Point 001 have been established, as required by 40 C.F.R. section 122.45(d)(2). Consistent with 40 C.F.R. section 133.101(f)(2), the 7-day average BOD₅ and TSS effluent concentrations achievable through proper operation and maintenance of the Facility, based on monitoring data representative of the effluent quality from the oxidations ponds collected from August 2012 through April 2019, were calculated as 1.5 times the AMEL. Based on the calculations, this Order establishes AWELs for BOD₅ and TSS of 57 mg/L and 48 mg/L, respectively. Compliance with the AWELs based on equivalent to secondary treatment requirements will be determined at Monitoring Location EFF-001 for emergency discharges to Humboldt Bay at Discharge Point 001.

Percent removal requirements for BOD₅ and TSS at Discharge Point 001 have been retained from Order No. R1-2012-0031 and are based on the equivalent to secondary treatment requirements in 40 C.F.R. section 133.105.

Equivalent to secondary treatment is consistent with WQ Order No. 79-20 because the revised secondary treatment regulations contained in 40 C.F.R. section 133.105 determined that the revised standards were equivalent to the Secondary Treatment Standards for facilities meeting the technological requirements, as described above.

- b. Secondary Treatment Standards (BOD₅ and TSS).** Under the upgraded Facility configuration, the Permittee will utilize oxidation ponds (i.e., waste stabilization ponds)

and a parallel oxidation ditch system to treat wastewater flows up to 5.9 mgd. Effluent from the waste stabilization pond and oxidation ditch treatment trains will be commingled prior to UV disinfection and discharge to the AMWS at Discharge Point 002. According to 40 C.F.R. section 133.101, a facility is only eligible for consideration for effluent limitations described for treatment equivalent to secondary treatment if a trickling filter or waste stabilization pond is used as the principle process. Under the upgraded Facility configuration, effluent from the waste stabilization pond treatment train will be commingled with effluent from the oxidation ditch treatment train, which does not utilize trickling filters or waste stabilization ponds as the principle process. Therefore, since equivalent to secondary treatment standards do not apply to the commingled effluent, secondary treatment standards at 40 C.F.R. part 133 apply to the discharge at Discharge Point 002 and establish the minimum level of effluent quality attainable by secondary treatment in terms of BOD₅ and TSS, including percent removal. Federal regulations at 40 C.F.R. section 122.45(h) allow internal monitoring points to be established when needed to determine compliance with a standard and in cases where setting an external monitoring location is not feasible. Therefore, compliance with technology-based effluent limits for BOD₅ and TSS based on secondary treatment requirements will be determined at Monitoring Location EFF-002 for discharges to the AMWS. Since compliance with technology-based effluent limits for BOD₅ and TSS will be determined at Discharge Point 002, under the upgraded Facility configuration, Discharge Point 003 does not include effluent limitations for BOD₅ and TSS.

- c. **pH.** The secondary treatment regulations at 40 C.F.R. part 133 apply to the discharge and require that pH be maintained between 6.0 and 9.0 standard units. Federal regulations at 40 C.F.R. section 122.45(h) allow internal monitoring points to be established when needed to determine compliance with a standard and in cases where setting an external monitoring location is not feasible. Effluent limitations for pH at Discharge Point 002 are necessary to ensure efficient operation of the AMWS as part of the Facility's treatment process prior to discharge to the brackish marsh. Therefore, this Order includes effluent limitations for pH at Discharge Point 002 based on the instantaneous maximum effluent limitation of 8.5 for pH as required at Discharge Points 001 and 003 to meet the water quality objective for Humboldt Bay established by chapter 3 of the Basin Plan.
- d. **Mass-Based Effluent Limitations.** Federal regulations at 40 C.F.R. section 122.45(f) require that, except under certain conditions, all permit limits, standards, or prohibitions be expressed in terms of mass units. Among the conditions exempting the application of mass-based limitations is 40 C.F.R. section 122.45(f)(1)(i), which states "*for pH, temperature, and radiation, or other pollutants which cannot appropriately be expressed by mass*" and 40 C.F.R. section 122.45(f)(1)(ii), which states "*when applicable standards and limitations are expressed in terms of other units of measurement.*"

This Order does not include mass-based effluent limitations for the following pollutants pursuant to the exceptions in 40 C.F.R. section 122.45(f)(1)(i) and (ii):

- i. BOD₅ and TSS, because these two parameters are expressed in terms of concentration and percent removal; and
- ii. pH because this parameter cannot appropriately be expressed by mass.

C. Water Quality-Based Effluent Limitations (WQBELs)

1. Scope and Authority

CWA section 301(b) and 40 C.F.R. section 122.44(d) require that permits include limitations more stringent than applicable federal technology-based requirements where necessary to achieve applicable water quality standards. This Order includes requirements more stringent than secondary treatment requirements that are necessary to meet Basin Plan requirements and applicable water quality standards for protection of beneficial uses.

Section 122.44(d)(1)(i) of 40 C.F.R. requires that permits include effluent limitations for all pollutants that are or may be discharged at levels that have the reasonable potential to cause or contribute to an exceedance of a water quality standard, including numeric and narrative objectives within a standard. Where reasonable potential has been established for a pollutant, but there is no numeric criterion or objective for the pollutant, WQBELs must be established using: (1) U.S. EPA criteria guidance under CWA section 304(a), supplemented where necessary by other relevant information; (2) an indicator parameter for the pollutant of concern; or (3) a calculated numeric water quality criterion, such as a proposed state criterion or policy interpreting the state's narrative criterion, supplemented with other relevant information, as provided in section 122.44(d)(1)(vi).

The process for determining reasonable potential and calculating WQBELs when necessary is intended to protect the designated uses of the receiving water as specified in the Basin Plan, and achieve applicable water quality objectives and criteria that are contained in other state plans and policies, or any applicable water quality criteria contained in the CTR and NTR.

2. Applicable Beneficial Uses and Water Quality Criteria and Objectives

- a. **Beneficial Uses.** Beneficial use designations for receiving waters for discharges from the Facility are presented in section III.C.1 of this Fact Sheet.
- b. **Basin Plan Water Quality Objectives.** In addition to the specific water quality objectives indicated above, the Basin Plan contains narrative objectives for color, tastes and odors, floating material, suspended material, settleable material, oil and grease, biostimulatory substances, sediment, turbidity, pH, dissolved oxygen, bacteria, temperature, toxicity, pesticides, chemical constituents, and radioactivity that apply to inland surface waters, enclosed bays, and estuaries, including Humboldt Bay and the brackish marsh. For waters designated for use as MUN, the Basin Plan establishes, as applicable water quality criteria, the MCLs established by the DDW for the protection of public water supplies at title 22 of the CCR section 64431 (Inorganic Chemicals) and section 64444 (Organic Chemicals).
- c. **SIP, CTR, and NTR.** Water quality criteria and objectives applicable to Humboldt Bay and the brackish marsh are established by the CTR, established by the U.S. EPA at 40 C.F.R. section 131.38; and the NTR, established by the U.S. EPA at 40 C.F.R. section 131.36. Criteria for most of the 126 CTR priority pollutants are contained within the CTR and the NTR.

The SIP, which is described in section III.C.3 of this Fact Sheet, includes procedures for determining the need for, and the calculation of, WQBELs and requires Permittees to submit data sufficient to do so.

At title 22, division 4, chapter 15 of the CCR, DDW has established MCLs for certain pollutants for the protection of drinking water. Chapter 3 of the Basin Plan establishes these MCLs as water quality objectives applicable to receiving waters with the beneficial use designation of municipal and domestic supply. As described in section

III.C.1 of this Fact Sheet, the municipal and domestic supply beneficial use is not applicable to the receiving waters in the vicinity of the discharge.

Aquatic life freshwater and saltwater criteria are identified as criterion maximum concentrations (CMC) and criterion continuous concentrations (CCC). The CTR defines the CMC as the highest concentration of a pollutant to which aquatic life can be exposed for a short period of time without deleterious effects and the CCC as the highest concentration of a pollutant to which aquatic life can be exposed for an extended period of time (4 days) without deleterious effects. The CMC is used to calculate an acute or 1-hour average numeric effluent limitation and the CCC is used to calculate a chronic or 4-day average numeric effluent limitation. The CTR at 40 C.F.R. section 131.38(c)(3)(iii) states that the more stringent of the freshwater or saltwater criteria are applicable for water in which the salinity is between 1 and 10 parts per thousand (ppt). Based on samples collected at the tide gate from the brackish marsh, the receiving water salinity ranged from 9.6 ppt to 36.1 ppt. Additionally, the salinity of the brackish marsh is expected to be reduced upon commencement of discharge at Discharge Point 003 when it will be, at times, dominated by effluent. Humboldt Bay and the brackish marsh are estuarine environments; therefore, consistent with 40 C.F.R. section 131.38(c)(3)(iii), freshwater and saltwater aquatic life criteria were both used for the RPA for Discharge Points 001 and 003.

Human health criteria are further identified as “water and organisms” and “organisms only”. “Water and organism” criteria are designed to address risks to human health from multiple exposure pathways. As stated in section III.C.1 of this Fact Sheet, the municipal and domestic supply beneficial use is not applicable to the receiving waters in the vicinity of the discharges; therefore, the “water and organisms” criteria do not apply and the “organisms only” criteria were used for the RPA.

3. Determining the Need for WQBELs

NPDES regulations at 40 C.F.R. section 122.44(d) require effluent limitations to control all pollutants, which are or may be discharged at a level that will cause, have the reasonable potential to cause, or contribute to an excursion above any state water quality standard. The RPA for this Facility was conducted as follows.

a. Non-Priority Pollutants

- i. Fecal Coliform.** Order No. R1-2012-0031 specified that the disinfected effluent discharged through Discharge Points 001 or 003 shall not contain concentrations of fecal coliform bacteria exceeding the following limitations:
 - (a)** The median concentration shall not exceed a Most Probable Number (MPN) of 14 organisms per 100 mL in a calendar month, and
 - (b)** Not more than 10 percent of samples collected in a calendar month shall exceed an MPN of 43 organisms per 100 mL.

These effluent limitations for fecal coliform bacteria have been retained from Order No. R1-2012-0031 and reflect water quality objectives for bacteria established by the Basin Plan for the protection of shellfish harvesting areas. For the protection of beneficial uses created by the AMWS, the point of compliance for fecal coliform bacteria effluent limitations for discharges to the brackish marsh has been moved from Discharge Point 003 to Discharge Point 002, following the UV disinfection system and prior to discharge to the AMWS. Because Humboldt Bay is home to large shellfish harvesting operations, it is appropriate to continue to retain fecal coliform limitations for the protection of shellfish harvesting areas.

The Basin Plan criteria are based on recommendations from the National Shellfish Sanitation Program's Fecal Coliform Standard for Adverse Pollution Conditions in the 2003 *Guide for the Control of Molluscan Shellfish, Model Ordinance for Shellstock Growing Areas* (U.S. Department of Health and Human Services, Public Health Service, Food and Drug Administration).

ii. Enterococci Coliform. On August 7, 2018, the State Water Board adopted Part 3 of the *Water Quality Control Plan for Inland Surface Waters, Enclosed Bays, and Estuaries of California – Bacteria Provisions and a Water Quality Standards Variance Policy* (Statewide Bacteria Provisions), which establishes water quality objectives for reasonable protection of people that recreate within all surface waters, enclosed bays, and estuaries of the state that have the water contact recreation beneficial use (REC-1). In accordance with the water quality objectives outlined in the Statewide Bacteria Provisions for the protection of freshwaters used for water contact recreation, disinfected effluent shall not contain *enterococci* bacteria exceeding the following limitations:

(a) The concentration of enterococci shall not exceed 30 colony forming units (cfu) per 100 milliliters (mL) as a six-week rolling geometric mean, calculated weekly.

(b) A statistical threshold value (STV) of 110 cfu/100 mL shall not be exceeded by more than 10 percent of the samples collected in a calendar month and calculated in a static manner.

As discussed in section IV.C.3.a.ii above, this Order contains effluent limitations for fecal coliform bacteria that reflect standards for the protection of shellfish harvesting areas. Because enterococci is a subset of the total coliform group, the enterococci limitations established in the Statewide Bacteria Provisions are not as stringent as the Basin Plan fecal coliform standards implemented in this Order.

Section IV.E.1 of the Statewide Bacteria Provisions states that “where a permit, WDR, or waiver of WDR includes an effluent limitation or discharge requirement derived from a water quality objective, guideline, or other requirement to control bacteria that is a more stringent value than the applicable bacteria water quality objective, the bacteria water quality objective shall not be implemented in the permit, WDR, or waiver of WDR.”

The effluent limitations established for fecal coliform will ensure that bacterial standards for water contact recreation are maintained throughout the receiving water.

iii. pH. Chapter 3, Table 3-1 of the Basin Plan includes site-specific water quality objectives for pH applicable to Humboldt Bay, which specify that the pH shall not be depressed below natural background levels nor raised above 8.5. For discharges to Humboldt Bay at Discharge Point 001, 002 and 003, this Order includes an instantaneous minimum effluent limitation for pH of 6.0 based on the secondary treatment standards at 40 C.F.R. part 133 and an instantaneous maximum effluent limitation for pH of 8.5 based on the site-specific maximum water quality objective for Humboldt Bay established in chapter 3, Table 3-1 of the Basin Plan. The federal technology-based maximum requirement prescribed in the secondary treatment standards at 40 C.F.R. part 133 is not sufficient to meet the Basin Plan water quality standard.

iv. Ammonia. Untreated domestic wastewater contains ammonia nitrogen. Nitrification is a biological process that converts ammonia to nitrite and nitrate.

Denitrification is a process that converts nitrate to nitrogen gas, which is then released to the atmosphere. Inadequate or incomplete nitrification may result in the discharge of ammonia to Humboldt Bay and the brackish marsh.

Ammonia is known to cause toxicity to aquatic organisms in surface waters. The Basin Plan establishes a narrative water quality objective for toxicity, stating that “[a]ll waters shall be maintained free of toxic substances in concentrations that are toxic to, or that produce detrimental physiological responses in human, plant, animal, or aquatic life.” Due to concerns regarding ammonia toxicity, the Regional Water Board relies on U.S. EPA’s recommended water quality criteria for ammonia to interpret the Basin Plan’s narrative objective for toxicity. For saltwater, the recommended criteria are from the April 1989 *Ambient Water Quality Criteria for Ammonia*, EPA-440/5-88-004 (1989 Saltwater Criteria). For freshwater, the recommended criteria are from the April 2013 *Aquatic Life Ambient Water Quality Criteria for Ammonia – Freshwater*, EPA 822-R-13-001 (2013 Freshwater Criteria). The 2013 Freshwater Criteria is an update to the December 1999 *Update of Ambient Water Quality Criteria for Ammonia* (1999 Freshwater Criteria).

The 1989 Saltwater Criteria document includes three tables of recommended criteria for receiving water salinities of 10 g/kg, 20 g/kg, and 30 g/kg. Based on samples collected at the tide gate from the brackish marsh, the receiving water salinity ranged from 9.6 ppt to 36.1 ppt. The salinity of the brackish marsh is expected to be reduced upon commencement of discharge at Discharge Point 003 when it will be, at times, dominated by effluent. Therefore, the table for receiving waters with salinity of 10 g/kg was used. The acute (1-hour average) and chronic (4-day average) criteria are based on pH and temperature.

The 2013 Freshwater Criteria recommends acute and chronic water quality criteria for the protection of aquatic life, including salmonids and sensitive freshwater mussel species in the Family Unionidae that are more sensitive to ammonia than salmonids. Like the 1999 Freshwater Criteria document, the 2013 Freshwater Criteria document recommends acute (1-hour average) criteria based on pH and the presence/absence of salmonids and chronic (30-day average) criteria based on pH and temperature and that no 4-day average concentration should exceed 2.5 times the 30-day chronic criterion. In addition, the 2013 Freshwater Criteria document recommends these same criteria for sensitive mussel species.

Adequate information is not available to determine if these freshwater mussels are present in the receiving water. The 2013 Freshwater Criteria document states, “*In the case of ammonia, where a state demonstrates that mussels are not present on a site-specific basis, the recalculation procedure may be used to remove the mussel species from the national criteria dataset to better represent the species present at the site.*”

Effluent monitoring results ranged from 0.40 mg/L to 18 mg/L based on 18 samples collected at Monitoring Location EFF-001 between August 2012 and May 2018. Monitoring for ammonia in the receiving water was not conducted over the term of Order No. R1-2012-0031.

Because ammonia levels in the effluent have been measured at concentrations greater than EPA’s 1989 Saltwater Criteria, the Regional Water Board concludes that discharges from the Facility have a reasonable potential to cause or contribute to exceedances of applicable water quality criteria for toxicity.

For this Order, the Regional Water Board has changed its approach for evaluating ammonia toxicity. This Order establishes an Ammonia Impact Ratio (AIR) for determining compliance with ammonia effluent limitations. The AIR is calculated as the ratio of the ammonia value in the effluent to the applicable 1989 Saltwater Criteria. See Attachment H of this Order for a sample log to help calculate and record the AIR values and Attachment G for applicable pH, temperature and salinity dependent criteria.

Therefore, this Order includes effluent limitations for ammonia for the protection of aquatic life. This Order establishes an average monthly effluent limitations (AMEL) and maximum daily effluent limitations (MDEL) for total ammonia, expressed as N, through the use of an AIR at Discharge Points 001 and 003 based on EPA's 1989 Saltwater Criteria. Calculations of the applicable multipliers are included in section IV.C.4 of this Fact Sheet.

- v. **Biostimulatory Substances (Phosphorus and Nitrogen).** The Basin Plan contains a narrative water quality objective for biostimulatory substances that states “[w]aters shall not contain biostimulatory substances in concentrations that promote aquatic growths to the extent that such growths cause nuisance or adversely affect beneficial uses.” The Regional Water Board is increasingly concerned about the biostimulatory properties of discharges to surface waters in the North Coast Region. Nutrients, such as phosphorus and nitrogen containing compounds, in treated wastewater stimulate biological growth, thereby depleting dissolved oxygen and advancing eutrophication of receiving waters. At present, for interpretation of the Basin Plan’s narrative water quality objective for biostimulatory substances, U.S. EPA has established recommended water quality criteria for nutrients in *Nutrient Criteria Documents for Lakes and Rivers and Nutrient Criteria Documents for Rivers and Streams*. U.S. EPA has defined 14 “ecoregions” and further categorized surface waters as lakes and reservoirs or rivers and streams for purposes of defining applicable numeric water quality criteria for nutrients. The State and Regional Water Boards continue to examine other methods of interpreting the Basin Plan’s narrative water quality objective for biostimulatory substances. When the Boards determine that U.S. EPA’s recommended criteria are appropriate for implementing the Basin Plan objectives, or when a more appropriate and meaningful method is established, the need for limiting nutrients in relation to biostimulatory properties, including phosphorus and nitrogen-containing compounds, in all discharges in the Region will be reassessed. In the meantime, the RPA for nutrients in relation to biostimulatory properties, performed for development of this Order, is inconclusive. The Order retains monitoring requirements for phosphorus and nitrogen containing compounds in discharges from the Facility to allow a determination of reasonable potential at such time as the State and Regional Water Boards select an appropriate method for interpretation of the Basin Plan’s narrative objective.

The Permittee sampled its discharge at Monitoring Location EFF-001 quarterly between August 2012 and April 2019. Monitoring results ranged between 0.1 mg/L and 2.7 mg/L based on 26 samples. The Permittee does not exhibit reasonable potential to exceed applicable water quality criteria for the receiving water for nitrate.

- vi. **Chlorine Residual.** The Basin Plan establishes a narrative water quality objective for toxicity which states “[a]ll waters shall be maintained free of toxic substances in concentrations that are toxic to, or that produce detrimental physiological responses in human, plant, animal, or aquatic life.” The Regional Water Board considers any

chlorinated discharge as having the reasonable potential to cause or contribute to exceedances of this water quality objective for toxicity, and therefore this Order includes effluent limitations for chlorine. U.S. EPA has established the following criteria for chlorine-produced oxidants for protection of freshwater aquatic life in Quality Criteria for Water 1986 (The Gold Book, 1986, EPA 440/5-86-001).

Chronic Criterion	Acute Criterion
0.011 mg/L	0.019 mg/L

Consistent with Order No. R1-2012-0031, the water quality criteria for total chlorine residual recommended by U.S. EPA have been translated to an AMEL of 0.01 mg/L and an MDEL of 0.02 mg/L in this Order, which will be applied at all times when the Facility utilizes chlorine for disinfection at Discharge Points 001 and 002. Under the existing Facility configuration, chlorine disinfection is utilized prior to discharge to Humboldt Bay at Discharge Point 001 and to the AMWS at Discharge Point 002. However, under the upgraded Facility configuration, following the construction of the UV disinfection system upstream of Discharge Point 002, chlorine disinfection will only be utilized for emergency discharges of the portion of flow exceeding 5.9 mgd at Discharge Point 001.

- vii. Settleable Solids.** Effluent limitations for settleable solids reflect levels of treatment attainable by secondary treatment facilities. These limitations are based on the Basin Plan water quality objective prohibiting bottom deposits for all surface waters of the North Coast Region. This Order applies the effluent limitations for settleable solids at Discharge Points 001 and 003 for discharges to Humboldt Bay and the brackish marsh.

Federal regulations at 40 C.F.R. section 122.45(h) allow internal monitoring points to be established when needed to determine compliance with a standard and in cases where setting an external monitoring location is not feasible. Effluent limitations for settleable solids at Discharge Point 002 are necessary to ensure efficient operation of the AMWS as part of the Facility’s treatment process prior to discharge to the brackish marsh and to protect the applicable beneficial uses. Therefore, this Order includes effluent limitations for settleable solids at Discharge Point 002 based on levels of treatment attainable by secondary treatment facilities.

b. CTR Priority Pollutants

The SIP establishes procedures to implement water quality criteria from the NTR and CTR and for priority, toxic pollutant objectives established in the Basin Plan. The implementation procedures of the SIP include methods to determine reasonable potential (for pollutants to cause or contribute to excursions above state water quality standards) and to establish numeric effluent limitations, if necessary, for those pollutants showing reasonable potential.

Section 1.3 of the SIP requires the Regional Water Board to use all available, valid, relevant, and representative receiving water and effluent data and information to conduct an RPA. For this Order, the Regional Water Board has conducted an RPA for discharges to Humboldt Bay at Discharge Point 001 and the brackish marsh at Discharge Point 003 using monitoring data collected at Monitoring Location EFF-001. During the term of Order No. R1-2012-0031, CTR priority pollutant sampling was conducted on August 5, 2013, October 14, 2013 (volatile organic compounds only), October 21, 2014, October 28, 2015, and September 22, 2016 at Monitoring Location EFF-001. In addition, the Permittee conducted monthly monitoring for copper and

cyanide, and quarterly monitoring for bis (2-ethylhexyl) phthalate, carbon tetrachloride, dichlorobromomethane, and TCDD-equivalents. All of this data was used to complete the RPA. No CTR priority pollutant data was available for the receiving water.

Hardness: The CTR and the NTR contain water quality criteria for seven metals that vary as a function of hardness; the lower the hardness, the lower the water quality criteria. The SIP requires water quality criteria be properly adjusted for hardness, using the hardness of the receiving water. The hardness-dependent metal criteria include cadmium, copper, chromium (III), lead, nickel, silver, and zinc. Receiving water hardness data was not available for Humboldt Bay or the brackish marsh in the vicinity of the outfalls. Humboldt Bay and the brackish marsh are estuarine environments, which are tidally influenced. Depending on the tide and season, these receiving waters may range from a predominantly freshwater/low hardness environment to a predominantly marine/high hardness environment. Because receiving water hardness data was not available for the RPA for Discharge Points 001 and 003, the Regional Water Board used a hardness value of 400 mg/L, which is the default high value for use in the RPA, as established in the CTR at section 131.38(c)(4)(i). This value may not be protective in all circumstances, and as receiving water hardness data is generated, the permit may be reopened to incorporate additional or more restrictive limitations, if necessary.

To conduct the RPA, Regional Water Board staff identified the maximum effluent concentration (MEC) and maximum background (B) concentration for each priority, toxic pollutant from effluent and receiving water data provided by the Permittee, and compared this information to the most stringent applicable water quality criterion (C) for each pollutant with applicable water quality criteria from the NTR, CTR, and the Basin Plan. Section 1.3 of the SIP establishes three triggers for a finding of reasonable potential.

Trigger 1. If the MEC is greater than C, there is reasonable potential, and an effluent limitation is required.

Trigger 2. If B is greater than C, and the pollutant is detected in effluent (MEC > ND), there is reasonable potential, and an effluent limitation is required.

Trigger 3. After a review of other available and relevant information, a permit writer may decide that a WQBEL is required. Such additional information may include, but is not limited to: the facility type, the discharge type, solids loading analyses, lack of dilution, history of compliance problems, potential toxic impact of the discharge, fish tissue residue data, water quality and beneficial uses of the receiving water, CWA 303(d) listing for the pollutant, and the presence of endangered or threatened species or their critical habitat.

c. Reasonable Potential Determination

The RPA demonstrated reasonable potential for discharges of copper (Discharge Point 003 only), cyanide, and TCDD-equivalents from the Facility to cause or contribute to exceedances of applicable water quality criteria. Reasonable potential could not be determined for all pollutants, as there are not applicable water quality criteria for all pollutants. The RPA determined that there is either no reasonable potential or there was insufficient information to conclude affirmative reasonable potential for 120 of the 126 CTR priority pollutants.

Table F-6 summarizes the RPA for each pollutant that was reported in detectable concentrations in the effluent or the receiving water. The MECs, most stringent water

quality objectives/water quality criteria (WQO/WQCs), and background concentrations (B) used in the RPA are presented, along with the RPA results (Yes or No and which trigger) for each toxic pollutant analyzed. No other pollutants with applicable, numeric water quality criteria from the NTR, CTR, and the Basin Plan were measured above detectable concentrations during the monitoring events conducted by the Permittee. Attachment F-1 to this Order summarizes the RPA for all 126 CTR priority pollutants.

Table F-6. Summary of Reasonable Potential Analysis Results

CTR #	Pollutant	Unit	C or Most Stringent WQO/WQC	MEC or Minimum DL ¹	B or Minimum DL ^{1,2}	RPA Results ³
1	Antimony	µg/L	4,300	2.7	Not Available	No
2	Arsenic	µg/L	36	1.3	Not Available	No
4	Cadmium	µg/L	7.3	0.34	Not Available	No
5a	Chromium (III)	µg/L	644	0.56	Not Available	No
5b	Chromium (VI)	µg/L	11	6.4	Not Available	No
6	Copper ⁴	µg/L	22 ⁵	7.6	Not Available	No
6	Copper ⁶	µg/L	3.7	7.6	Not Available	Yes (Trigger 1)
8	Mercury	µg/L	0.051	0.00368	Not Available	No
9	Nickel	µg/L	8.3	3.9	Not Available	No
10	Selenium	µg/L	5.0	1.1	Not Available	No
12	Thallium	µg/L	6.3	0.23	Not Available	No
13	Zinc	µg/L	86	7.2	Not Available	No
14	Cyanide	µg/L	1.0	7.0	Not Available	Yes (Trigger 1)
21	Carbon Tetrachloride	µg/L	4.4	0.80	Not Available	No
23	Chlorodibromomethane	µg/L	34	1.3	Not Available	No
26	Chloroform	µg/L	No Criteria	13	Not Available	No
27	Dichlorobromomethane	µg/L	46	5.7	Not Available	No
39	Toluene	µg/L	200,000	0.29	Not Available	No
54	Phenol	µg/L	4,600,000	2.1	Not Available	No
68	Bis (2-ethylhexyl) phthalate	µg/L	5.9	2.8	Not Available	No
94	Naphthalene	µg/L	No Criteria	0.047	Not Available	No
Not Applicable	TCDD-Equivalents	µg/L	1.4 x 10 ⁻⁸	2.85 x 10 ⁻⁷	Not Available	Yes (Trigger 1)

CTR #	Pollutant	Unit	C or Most Stringent WQO/WQC	MEC or Minimum DL ¹	B or Minimum DL ^{1,2}	RPA Results ³
Not Applicable	Ammonia	mg/L	0.29 ⁷	18	Not Available	Yes (Trigger 1)
Not Applicable	Nitrate	mg/L	10	2.7	Not Available	No

Table Notes:

1. The Maximum Effluent Concentration (MEC) or maximum background concentration (B) is the actual detected concentration unless it is preceded by "<", in which case the value shown is the minimum detection level as the analytical result was reported as not detected (ND).
2. The MEC or B is "Not Available" when there is no monitoring data for a constituent.
3. RPA Results:
 = Yes, if MEC > WQO/WQC, or B > WQO/WQC and MEC is detected.
 = No, if MEC and B or < WQO/WQC or all effluent data are undetected.
 = Undetermined (UD).
4. Applies only to Humboldt Bay at Discharge Point 001.
5. Copper WQO calculated with a water effects ratio (WER) of 5.76 and the most stringent WQO from the CTR using a hardness of 400 mg/L ($5.76 \times 7.3 = 22 \mu\text{g/L}$).
6. Applies only to the brackish marsh at Discharge Point 003.
7. The saltwater criterion represented in this table is based upon chronic exposure and a temperature of 23.2°C, a pH of 8.4, and a salinity value of 10 g/kg.

Additional details regarding CTR priority pollutant constituents for which reasonable potential was found are included in the following paragraphs:

Copper. Order No. R1-2012-0031 included effluent limitations for copper. The CTR includes criteria for the protection of saltwater aquatic life and hardness-dependent criteria for the protection of freshwater aquatic life for copper. The criteria for copper is in dissolved concentrations. U.S. EPA recommends conversion factors to translate dissolved concentrations to total concentrations. The U.S. EPA default conversion factors for copper in freshwater are 0.96 for both the acute and the chronic criteria. The default WER used for calculating criteria for copper is 1.0. The Permittee has conducted a WER study to determine the site-specific toxicity of copper in the receiving water at Discharge Point 001. The Permittee's study concluded that a site specific WER of 5.76 for total recoverable copper applies to the discharge at Discharge Point 001. Using a receiving water hardness of 400 mg/L, the U.S. EPA recommended dissolved-total translator of 0.96, and the site-specific WER, the applicable chronic criterion (maximum 4-day average concentration) is adjusted to 22 µg/L and the applicable acute criterion (maximum 1-hour average concentration) is adjusted to 33 µg/L for discharges at Discharge Point 001. Because the WER study did not present data collected at Discharge Point 003, the default WER was used for calculating copper criteria for discharges to the brackish marsh. Using a receiving water hardness of 400 mg/L, the U.S. EPA recommended dissolved-total translator of 0.96, and the default WER, the applicable chronic criterion is 3.7 µg/L and the applicable acute criterion is 5.8 µg/L for discharges at Discharge Point 003.

The Permittee sampled the effluent for copper 33 times during the term of Order No. R1-2012-0068. Copper was detected in all 33 effluent samples, with results ranging from 1.4 µg/L to 7.6 µg/L. A determination of reasonable potential has been made for discharges at Discharge Point 003 only, based on the MEC of 7.6 µg/L exceeding the most stringent water quality objective of 3.7 µg/L.

Cyanide. Order No. R1-2012-0031 included effluent limitations for cyanide. The CTR establishes a water quality objective for the protection of saltwater aquatic life of 1.0 µg/L and a water quality objective for the protection of freshwater aquatic life of 5.2 µg/L for

cyanide. The Permittee sampled the effluent for cyanide 57 times during the term of Order No. R1-2012-0068. Cyanide was detected in 26 of the effluent samples, with results ranging from 0.97 µg/L to 7.0 µg/L. A determination of reasonable potential has been made for discharges from Discharge Points 001 and 003 based on the MEC of 7.0 µg/L exceeding the most stringent water quality objective of 1.0 µg/L. Effluent limitations for cyanide will be applied at Discharge Points 001 and 003.

2,3,7,8-TCDD and TCDD-Equivalents. Order No. R1-2012-0068 included effluent limitations for TCDD-equivalents. The CTR establishes a water quality criterion for the protection of human health for 2,3,7,8-TCDD of 1.3×10^{-8} µg/L. The CTR and Basin Plan do not establish water quality objectives for TCDD-equivalents; however, the CTR criterion for 2,3,7,8-TCDD can be used to interpret the Basin Plan's narrative toxicity objective for TCDD-equivalents. The Permittee sampled the effluent for 2,3,7,8-TCDD and the other 16 dioxin and furan congeners 17 times during the term of Order No. R1-2012-0031. Congeners were detected in all 17 effluent samples, with TCDD-equivalents totals ranging from 1.99×10^{-9} µg/L to 2.9×10^{-7} µg/L. Additionally, there are known industrial users within the Permittee's service area and Humboldt Bay is listed in CWA section 303(d) as impaired for dioxins. Therefore, a determination of reasonable potential has been made based for TCDD-equivalents based on the MEC of 2.9×10^{-7} µg/L exceeding the most stringent applicable water quality objective of 1.3×10^{-8} µg/L and Humboldt Bay's listing in CWA section 303(d) as impaired for dioxins. Effluent limitations for TCDD-equivalents will be applied at Discharge Points 001 and 003.

Additional details regarding CTR priority pollutant constituents for which reasonable potential was not found but warrant further explanation are included in the following paragraphs:

Carbon Tetrachloride. Order No. R1-2012-0031 included effluent limitations for carbon tetrachloride at Discharge Points 001 and 003. The CTR establishes a water quality objective for carbon tetrachloride for the protection of human health for waters from which organisms are consumed of 4.4 µg/L. The Permittee sampled the effluent for carbon tetrachloride 21 times during the term of Order No. R1-2012-0031. Carbon tetrachloride was detected in the effluent in one sample, with a result of 0.80 µg/L. Receiving water monitoring for carbon tetrachloride was not conducted over the term of Order No. R1-2012-0031. Since the MEC was less than the applicable water quality objective for carbon tetrachloride, a determination of no reasonable potential has been made and effluent limitations have not been retained in this Order.

Dichlorobromomethane. Order No. R1-2012-0031 included effluent limitations for dichlorobromomethane at Discharge Point 001. The CTR establishes a water quality objective for dichlorobromomethane for the protection of human health for waters from which organisms are consumed of 46 µg/L. The Permittee sampled the effluent for dichlorobromomethane 22 times during the term of Order No. R1-2012-0031. Dichlorobromomethane was detected in the effluent in 20 samples, with results ranging from 0.55 µg/L to 5.7 µg/L. Receiving water monitoring for dichlorobromomethane was not conducted over the term of Order No. R1-2012-0031. Since the MEC was less than the applicable water quality objective for dichlorobromomethane, a determination of no reasonable potential has been made and effluent limitations at Discharge Point 001 have not been retained in this Order.

Bis (2-Ethylhexyl) Phthalate. Order No. R1-2012-0031 included effluent limitations for bis (2-ethylhexyl) phthalate at Discharge Points 001 and 003. The CTR establishes a water quality objective for bis (2-ethylhexyl) phthalate for the protection of human health for waters from which organisms are consumed of 5.9 µg/L. The Permittee sampled the effluent for bis (2-ethylhexyl) phthalate 22 times during the term of Order No. R1-2012-0031. Bis

(2-ethylhexyl) phthalate was detected in the effluent in five samples, with results ranging from 1.1 µg/L to 2.8 µg/L. Receiving water monitoring for bis (2-ethylhexyl) phthalate was not conducted over the term of Order No. R1-2012-0031. Since the MEC was less than the applicable water quality objective for bis (2-ethylhexyl) phthalate, a determination of no reasonable potential has been made and effluent limitations have not been retained in this Order.

4. **WQBEL Calculations**

Final WQBELs have been determined using the methods described in section 1.4 of the SIP.

Step 1: To calculate the effluent limits, an effluent concentration allowance (ECA) is calculated for each pollutant found to have reasonable potential using the following equation, which takes into account dilution and background concentrations:

$$ECA = C + D (C - B),$$

Where:

C = the applicable water quality criterion (adjusted for effluent hardness and expressed as the total recoverable metal, if necessary)

D = dilution credit (here D= 0, as the discharge does not qualify for a dilution credit)

B = background concentration

Here, no credit for dilution is allowed, which results in the ECA being equal to the applicable criterion (ECA = C).

Step 2: For each ECA based on an aquatic life criterion/objective (copper, cyanide, and ammonia), the long-term average discharge condition (LTA) is determined by multiplying the ECA by a factor (multiplier), which adjusts the ECA to account for effluent variability. The multiplier depends on the coefficient of variation (CV) of the data set and whether it is an acute or chronic criterion/objective. Table 1 of the SIP provides pre-calculated values for the multipliers based on the values of the CV. When the data set contains less than 10 sample results, or when 80 percent or more of the data set is reported as ND, the CV is set equal to 0.6. Derivation of the multipliers is presented in section 1.4 of the SIP.

The SIP procedure assumes a 4-day averaging period for calculating the LTA. However, U.S. EPA recommends modifying the procedure for calculating permit limits for ammonia using a 30-day averaging period for the calculation of the LTA corresponding to the 30-day CCC. Therefore, while the LTAs corresponding to the acute and 4-day chronic criteria were calculated according to SIP procedures, the LTA for ammonia corresponding to the 30-day CCC was calculated assuming a 30-day averaging period.

From Table 1 in the SIP, the ECA multipliers for calculating LTAs at the 99th percentile occurrence probability for copper are 0.461 (acute multiplier) and 0.662 (chronic multiplier). The ECA multipliers for cyanide are 0.247 (acute multiplier) and 0.436 (chronic multiplier). The ECA multipliers for ammonia are 0.210 (acute multiplier), 0.382 (chronic 4-day multiplier), and 0.675 (chronic 30-day multiplier). The LTAs are determined as follows in Table F-7.

Table F-7. Determination of Long Term Averages

Pollutant	Units	ECA		ECA Multiplier		LTA	
		Acute	Chronic	Acute	Chronic	Acute	Chronic
Copper, Total Recoverable	µg/L	5.8	3.7	0.461	0.662	2.67	2.45
Cyanide, Total (as CN)	µg/L	1.0	1.0	0.247	0.436	0.247	0.436
Ammonia (as N) ¹	mg/L	1.9	0.29	0.210	0.382	0.399	0.111

Table Notes:

1. Ammonia LTAs were calculated based on applicable saltwater aquatic life criteria.

Step 3: WQBELs, including an AMEL and MDEL, are calculated using the most limiting (lowest) LTA. The LTA is multiplied by a factor that accounts for averaging periods and exceedance frequencies of the effluent limitations, and for the AMEL, the effluent monitoring frequency. The CV is set equal to 0.37 for copper, 0.81 for cyanide, and 0.97 for ammonia. The sampling frequency is set equal to 4 (n = 4) for both the acute and chronic criteria. The 99th percentile occurrence probability was used to determine the MDEL multiplier and a 95th percentile occurrence probability was used to determine the AMEL multiplier. From Table 2 of the SIP, the MDEL multiplier for copper is 2.17 and the AMEL multiplier is 1.33. From Table 2 of the SIP, the MDEL multiplier for cyanide is 4.05 and the AMEL multiplier is 1.76. From Table 2 of the SIP, the MDEL multiplier for ammonia is 4.76 and the AMEL multiplier is 1.91. Final WQBELs for copper and cyanide are determined as follows.

Table F-8. Determination of Final WQBELs Based on Aquatic Life Criteria

Pollutant	Unit	LTA	MDEL Multiplier	AMEL Multiplier	MDEL	AMEL
Copper, Total Recoverable	µg/L	2.45	2.17	1.33	5.3	3.3
Cyanide, Total (as CN)	µg/L	0.247	4.05	1.76	1.0	0.43

Final WQBELs for ammonia are determined by calculating the AIR for each of the ammonia standards (AMEL and MDEL). Attachment H of this Order includes two tables that display the AMEL and MDEL ammonia standards. The ammonia standards are calculated by taking the variable ammonia criteria and multiplying it by the ECA multiplier and the appropriate AMEL and MDEL multiplier. The 2013 ammonia criteria are dependent on the pH and temperature of the receiving water. For example:

$$\text{AMEL Ammonia Standard} = (1989 \text{ Chronic Ammonia Criteria (ECA)} * \text{AMEL Multiplier (1.91)} * \text{ECA Multiplier (0.38)})$$

$$\text{MDEL Ammonia Standard} = (1989 \text{ Chronic Ammonia Criteria (ECA)} * \text{MDEL Multiplier (4.76)} * \text{ECA Multiplier (0.38)})$$

The AIR, or final WQBEL, is determined by dividing the ammonia sample by the appropriate ammonia standard (AMEL and MDEL). If the AIR is greater than 1.0 then the Permittee is not in compliance with the AIR effluent limitation.

Step 4: When the most stringent water quality criterion/objective is a human health criterion/objective (as for TCDD-equivalents), the AMEL is set equal to the ECA. From Table 2 of the SIP, when CV = 0.85 and n = 4, the MDEL multiplier at the 99th percentile occurrence probability equals 4.25, and the AMEL multiplier at the 95th percentile occurrence probability equals 1.80 (for TCDD-equivalents). The MDEL for protection of human health is calculated by multiplying the ECA by the ratio of the MDEL multiplier to the AMEL multiplier. Final WQBELs for TCDD-equivalents are determined as follows.

Table F-9. Determination of Final WQBELs Based on Human Health Criteria

Pollutant	ECA (µg/L)	MDEL/AMEL	MDEL (µg/L)	AMEL (µg/L)
TCDD-Equivalents	1.4 x 10 ⁻⁸	2.4	3.3 x 10 ⁻⁸	1.4 x 10 ⁻⁸

5. Whole Effluent Toxicity (WET)

Monitoring and effluent limitations for whole effluent toxicity protect the receiving water from the aggregate effect of a mixture of pollutants that may be present in the effluent. There are two types of WET tests – acute and chronic. An acute toxicity test is conducted over a short time period and measures mortality. A chronic test is conducted over a longer period of time and may measure mortality, reproduction, and/or growth.

WET requirements are derived from the CWA and the Basin Plan. The Basin Plan establishes a narrative water quality objective for toxicity that states “*All waters shall be maintained free of toxic substances in concentrations that are toxic to, or that produce detrimental physiological responses in human, plant, or aquatic life.*” Detrimental responses may include, but are not limited to, decreased growth rate, decreased reproductive success of resident or indicator species, and/or significant alterations in population, community ecology, or receiving water biota. For compliance with the Basin Plan’s narrative toxicity objective, this Order requires the Permittee to conduct WET testing for acute and chronic toxicity, as specified in the MRP (Attachment E, section V).

a. Acute Aquatic Toxicity

Consistent with Order No. R1-2012-0031, this Order includes effluent limitations for acute toxicity at Discharge Points 001 and 003 in accordance with the Basin Plan, which requires that the average survival of test organisms in undiluted effluent for any three consecutive 96-hour bioassay tests be at least 90 percent, with no single test having less than 70 percent survival.

The Order implements federal guidelines (Regions 9 and 10 Guidelines for Implementing Whole Effluent Toxicity Testing Programs) by requiring the Permittee to conduct acute toxicity tests on a fish species and on an invertebrate species to determine the most sensitive species. According to the U.S. EPA manual, *Methods for Estimating the Acute Toxicity of Effluents and Receiving Waters to Freshwater and Marine Organisms* (EPA/600/4-90/-27F), the acceptable vertebrate species for the acute toxicity test are the sheepshead minnow, *Cyprinodon variegatus*, the fathead minnow, *Pimephales promelas*, and the rainbow trout, *Oncorhynchus mykiss*. The acceptable invertebrate species for the acute toxicity test are the mysid shrimp, *Mysidopsis bahia*, and the water flea, *Ceriodaphnia dubia*, *Daphnia magna*, and *D. pulex*. This Order requires the Permittee to conduct a screening test using a vertebrate and invertebrate species. After the screening test is completed, monitoring can be reduced to the most sensitive species. Attachment E of this Order requires annual acute WET monitoring.

b. Chronic Aquatic Toxicity

The SIP requires the use of short-term chronic toxicity tests to determine compliance with the narrative toxicity objectives for aquatic life in the Basin Plan. The SIP requires that the Permittee demonstrate the presence or absence of chronic toxicity using tests on a vertebrate, an invertebrate, and an aquatic plant, in accordance with the species identified in section V.B.4 of the MRP (Attachment E). At least one time every five years, the Permittee shall conduct a re-screen test with the three identified species and continue routine monitoring with the most sensitive species. Attachment E of this

Order requires quarterly chronic WET monitoring to demonstrate compliance with the narrative toxicity objective.

The receiving waters at Discharge Points 001 and 003 are estuarine and depending on tide and time of year, may range from predominantly freshwater environments to predominantly marine environments. Therefore, the Permittee, when collecting samples for toxicity, shall also determine the characteristics of the receiving water at the time of species screening to ensure the proper test species and method are implemented, as described in section V of the MRP (Attachment E).

The Permittee conducted chronic toxicity testing using *C. dubia*. The following table summarizes the chronic toxicity testing results from the term of Order No. R1-2012-0031.

Table F-10. Summary of Chronic Toxicity Results

Date	<i>Ceriodaphnia dubia</i>	
	Survival (TUC)	Reproduction (TUC)
December 11, 2012	1	1
March 5, 2013	1	1.3
May 7, 2013	1	1.3
June 4, 2013	1	2
June 11, 2013	1	1.3
June 18, 2013	1	1
June 25, 2013	1	1
July 9, 2013	1	1
December 10, 2013	1	1.3
March 17, 2014	1	1.3
April 15, 2014	1	1
April 22, 2014	1	1
April 29, 2014	1	1
May 20, 2014	1	1
August 19, 2014	1	1
October 14, 2014	1	2
February 10, 2015	1	1.3
March 12, 2015	1	>8
March 19, 2015	1	2
March 26, 2015	1	1
April 2, 2015	1	1
August 18, 2015	1	1
November 3, 2015	1	1
February 13, 2016	1	1
May 10, 2016	1	1
July 19, 2016	1	1
December 13, 2016	1	1

Based on the observed chronic toxicity to *C. dubia* reproduction on March 5, 2013, May 7, 2013, June 4, 2013, June 11, 2013, December 10, 2013, March 17, 2014, October 14, 2014 February 10, 2015, March 12, 2015, and March 19, 2015, the Regional Water Board concludes that the discharge has reasonable potential to cause or contribute to an exceedance of the Basin Plan’s narrative toxicity objective. Therefore, this Order establishes a narrative effluent limitation for chronic toxicity.

Numeric chronic toxicity effluent limitations have not been included in the Order for consistency with the SIP, which implements narrative toxicity objectives in basin plans and specifies use of a numeric trigger for accelerated monitoring and implementation

of a Toxicity Reduction Evaluation (TRE) in the event that persistent toxicity is detected. The SIP contains implementation gaps regarding the appropriate form and implementation of chronic toxicity limits. This has resulted in the petitioning of a NPDES permit in the Los Angeles Region that contained numeric chronic toxicity effluent limitations. To address the petition, the State Water Board adopted WQO 2003-0012 directing its staff to revise the toxicity control provisions in the SIP. The State Water Board states the following in WQO 2003-012, *"In reviewing this petition and receiving comments from numerous interested persons on the propriety of including numeric effluent limitations for chronic toxicity in NPDES permits for publicly-owned treatment works, that discharge to inland waters, we have determined that this issue should be considered in a regulatory setting, in order to allow for full public discussion and deliberation. We intend to modify the SIP to specifically address the issue. We anticipate that review will occur within the next year. We therefore decline to make a determination here regarding the propriety of the final numeric effluent limitations for chronic toxicity contained in these permits."* The process to revise the SIP is underway. Proposed changes include clarifying the appropriate form of effluent toxicity limits in NPDES permits and general expansion and standardization of toxicity control implementation related to the NPDES permitting process. Since the toxicity control provisions in the SIP are under revision, it is infeasible to develop numeric effluent limitations for chronic toxicity at this time. The SIP revision may require a permit modification to incorporate new statewide toxicity criteria established by the upcoming SIP revision.

This Order includes a reopener that allows the Regional Water Board to reopen the Order and includes a numeric chronic toxicity limitation, a revised acute toxicity limitation, and/or a limitation for a specific toxicant identified in the TRE.

To ensure compliance with the narrative effluent limitation and the Basin Plan's narrative toxicity objective, the Permittee is required to conduct quarterly chronic WET testing at Discharge Point 003 and annual chronic WET testing at Discharge Point 001, as specified in the MRP (Attachment E, section V.B). Furthermore, the MRP (Attachment E, section V.C) requires the Permittee to investigate the causes of, and identify and implement corrective actions to reduce or eliminate effluent toxicity. If the discharge demonstrates toxicity exceeding the numeric toxicity monitoring trigger, the Permittee is required to initiate a TRE in accordance with an approved TRE Work Plan. The numeric toxicity monitoring trigger is not an effluent limitation; it is the toxicity threshold at which the Permittee is required to perform accelerated chronic toxicity monitoring, as well as the threshold to initiate a TRE if a pattern of effluent toxicity has been demonstrated.

c. Test of Significant Toxicity (TST)

Order No. R1-2012-0031 established numeric chronic toxicity triggers of 1.0 TUc = 100/NOEC as a three-sample median and 2.0 TUc = 100/NOEC as a single sample maximum, using a five-concentration hypothesis test. In 2010, U.S. EPA endorsed the peer-reviewed *Test of Significant Toxicity (TST) two-concentration hypothesis testing approach in National Pollutant Discharge Elimination System Test of Significant Toxicity Implementation Document* (EPA 833-R-10-003, 2010) as an improved hypothesis-testing tool to evaluate data from U.S. EPA's toxicity test methods. The TST hypothesis testing approach more reliably identifies toxicity—in relation to the chronic (0.25 or more) mean response of regulatory management concern—than the No Observed Effect Concentration (NOEC) hypothesis-testing approach. The TST hypothesis testing approach more reliably identifies toxicity – in relation to the acute (0.20 or more) mean

responses of regulatory management concern – than the NOEC approach used previously to establish effluent limitations for acute toxicity.

Since the TST approach has not previously been applied for determining reasonable potential or establishing effluent limitations for acute toxicity, this Order does not include effluent limitations for acute toxicity based on the TST approach. However, this Order does require the Permittee to monitor and report results in a manner that will allow the Regional Water Board to conduct an RPA in accordance with the TST approach at the time of the next permit renewal.

The State Water Board is developing a toxicity amendment to the Enclose Bays and Estuaries Policy that will standardize the regulation of aquatic toxicity for all non-oceanic surface waters. U.S. EPA's TST approach is an essential component of this draft toxicity amendment as it forms the basis for utilizing numeric water quality objectives and acts as the primary means of determining compliance with the proposed effluent limitations.

In a letter dated February 12, 2014, the State Water Board submitted an alternative test process (ATP) request to U.S. EPA Region 9 for the statewide use of a two-concentration toxicity test design when using the TST approach. This two-concentration test design is composed of a single effluent concentration and a control concentration. U.S. EPA approved the ATP request on March 17th, 2014. In June 2014, the approval was challenged in court on procedural grounds under the Administrative Procedures Act by the Southern California Alliance of Publicly Owned Treatment Works (SCAP) and the Central Valley Clean Water Association (CVCWA). The U.S. EPA withdrew the approval and notified State Water Board in a memo dated February 11, 2015.

It is important to note that U.S. EPA's rescission of its approval of the ATP is not based on the substantive TST statistical analysis or the scientific validity of a two-concentration test design. The withdrawal letter also states that currently there is a proposed rulemaking to change the language in the ATP regulations at 40 C.F.R. part 136.

The benefits of requiring the TST in new or amended permits include improving the statistical power of the toxicity test and simplifying the analysis as compared to the traditional hypothesis statistical approaches or point estimates. The calculations are straightforward and provide a clear pass/fail result. With the withdrawal of the two-concentration test design approval, an NPDES permit can still require the TST for statistical analyses. Toxicity tests shall be run using a multi-concentration test design in accordance with 40 C.F.R. section 136.3, and the TST shall be utilized with the biological responses from the permitted in-stream waste concentration (IWC) and the control (effluent concentration of zero). However, even with only two of the five concentration biological responses being used, cost savings in the form of time and effort are still realized for the statistical analysis and data interpretation carried out by the Permittee, lab, and permit manager. This Order requires application of the TST for statistical analysis of whole effluent toxicity data.

Tests of Significant Toxicity Design

The TST's null hypothesis for chronic toxicity is:

H_0 : Mean response (IWC in % effluent) \leq 0.75 mean response (control)

Results are analyzed using the TST approach and an acceptable level of chronic toxicity is demonstrated by rejecting the null hypothesis and reporting "Pass" or "P".

The chronic IWC (in % effluent) for Discharge Points 001 and 003 is 100%. The chronic toxicity trigger for Discharge Points 001 and 003 is expressed as a null hypothesis (H_0) and regulatory management decision (b value) of 0.75 for the chronic toxicity methods in the MRP. The null hypothesis for this discharge is:

H_0 : Mean response (100% effluent) \leq 0.75 mean response (control)

Results shall be analyzed using the TST hypothesis testing approach in section V.B.6.a of the MRP. Compliance with this chronic toxicity limitation is demonstrated by rejecting the null hypothesis and reporting "Pass" or "P".

When the chronic toxicity test results in a "Fail" or "F," the Permittee must initiate accelerated monitoring as specified in the MRP (Attachment E, section V). After accelerated monitoring, if conditions of chronic toxicity are found to persist, the Permittee will be required to conduct a TRE, as described by the MRP.

Notification requirements for chronic WET testing include a 72-hour verbal notification requirement and a 14-day written report requirement, if test results indicate toxicity. The 14-day written notification is established in the U.S. EPA WET Guidance documents cited in the MRP. The 72-hour verbal notification requirement is being added to provide the Regional Water Board with knowledge of the toxicity in advance of the written report. The 72-hour requirement is intended to give the Permittee sufficient time to make a telephone call to Regional Water Board staff and accounts for non-working days (e.g., weekends). Verbal notification of WET test exceedances may be left by voice mail if the Regional Water Board staff person is not immediately available by telephone.

This Order includes a requirement for the Permittee to conduct a screening test using at least one vertebrate, invertebrate, and plant species. After the screening test is completed, monitoring can be reduced to the most sensitive species.

Chronic WET limitations will be established if future monitoring results demonstrate that discharges from the Facility are causing or contributing to chronic toxicity in the receiving water.

D. Final Effluent Limitation Considerations

1. Anti-Backsliding Requirements

Sections 402(o) and 303(d)(4) of the CWA and federal regulations at 40 C.F.R. section 122.44(l) prohibit backsliding in NPDES permits. These anti-backsliding provisions require effluent limitations in a reissued permit to be as stringent as those in the previous permit, with some exceptions where limitations may be relaxed. All effluent limitations in this Order are at least as stringent as the effluent limitations in Order No. R1-2012-0031, with the exception of mass-based effluent limitations for BOD₅ and TSS at Discharge Points 001 and 003; effluent limitations for dichlorobromomethane at Discharge Point 001; and effluent limitations for carbon tetrachloride, bis (2-ethylhexyl) phthalate, and TCDD-equivalents at Discharge Points 001 and 003.

Order No. R1-2012-0031 established final mass-based effluent limitations for BOD₅ and TSS. Mass limitations for BOD₅ and TSS for discharges of treated wastewater have been removed because Regional Water Board staff misinterpreted the exception of 40 C.F.R. section 122.45(f)(2), which states that mass limitations are not required "*when applicable standards and limitations are expressed in terms of other units of measure.*" Secondary treatment standards for BOD₅ and TSS in 40 C.F.R. section 133.102, on which the effluent limitations in previous permits were based, are expressed in concentration and percent removal (i.e., other units of measure). The relaxation of effluent limitations for BOD₅ and TSS in this Order

is permissible under CWA section 402(o)(2)(B), because Regional Water Board staff has determined that mass-based limitations for BOD₅ and TSS were applied in the previous permits as a result of a mistaken interpretation of law when issuing those previous permits.

Historically, the Regional Water Board routinely incorporated mass-based limits (in addition to concentration-based limits) for BOD₅ and TSS in NPDES permits to encourage correction of Inflow & Infiltration (I&I). Applied in this way, mass-based limitations effectively restrict a POTW's wet-weather influent flows to less than or equal to the treatment facility's design capacity in situations where POTW's experience excessive I&I as a result of climate conditions and/or aging infrastructure.

In addition, Regional Water Board staff previously held that anti-backsliding regulations prevented the removal of mass-based limitations for BOD₅ and TSS because they were appropriate and necessary to protect water quality and prevent water quality degradation in receiving waters. While it is conceivable that the absence of mass-based limitations for these pollutants may result in an increased pollutant loading to surface waters, even if there is a resulting increase in pollutant loading, there is no evidence that the increase will result in degradation of water quality. Therefore, relaxation of effluent limitations for BOD₅ and TSS in this Order is also permissible under CWA section 402(o)(2)(B), based on new information available to the Regional Water Board.

Regional Water Board staff conducted an I&I analysis utilizing the definitions of excessive I&I in the federal regulations at 40 C.F.R. sections 35.2005(b) and 133.103(d). Using influent flow data collected between August 2012 and January 2017 and a population of 18,695 as reported in the ROWD, the Regional Water Board conducted an analysis of per capita flows for comparison with the definitions of "excessive I&I" in 40 C.F.R section 35.2005(b)(28) and 133.103(d) (i.e., greater than 275 gpd per capita per day). Effluent flows exceeded 275 gpd per capita on 33 occasions.

In addition, the methodology in a report titled *Recommended Standards for Wastewater Treatment Facilities, Policy for the Design, Review, and Approval of Plans and Specifications for Wastewater Collection and Treatment Facilities*, 2014 Edition, A Report of the Wastewater Committee of the Great Lakes-Upper Mississippi River Board of State and Provincial Public Health and Environmental Managers was used to calculate a peaking factor, above which excessive infiltration is indicated. Using Figure 1 of this methodology report, a peaking factor of 2.7 is the maximum rate of wastewater flow that is calculated for a population of 18,695. The analysis revealed 14 exceedances of the peaking factor, with exceedances ranging from 2.8 to 4.0.

The Permittee acknowledged I&I issues in the ROWD, noting that an additional 1.47 mgd flow into the treatment works during wet weather period as a result of I&I. At the time the ROWD was submitted, the Permittee had submitted an application for \$7 million in Clean Water State Revolving Funds for identified I&I projects, scheduled to begin in September 2017. The Permittee has made significant repairs to the collection system in the last two years. The Permittee has plans to utilize the remaining \$7 million to resolve identified I&I issues in the collection system.

Order No. R1-2012-0031 included effluent limitations for carbon tetrachloride at Discharge Points 001 and 003 based on the CTR human health criterion for waters from which both water and organisms are consumed. Based on receiving water salinity monitoring conducted by the Discharger, salinity in Humboldt Bay in the vicinity of the discharge exceeds the salinity threshold in Resolution No. 88-63. Therefore, this Order does not apply the MUN designation to Humboldt Bay and only the CTR human health criteria for waters from which organisms are consumed are applicable to the discharge. As shown in Table F-6 of this Fact Sheet, effluent monitoring data for carbon tetrachloride indicates that the

discharge does not demonstrate reasonable potential to cause or contribute to an exceedance of the applicable CTR human health criterion. The updated effluent carbon tetrachloride data and the updated receiving water salinity data constitute new information, which permits the removal of effluent limitations consistent with CWA section 402(o)(2)(B). Therefore, this Order does not retain effluent limitations for carbon tetrachloride at Discharge Point 001 nor Discharge Point 003.

Order No. R1-2012-0031 included effluent limitations for dichlorobromomethane at Discharge Point 001 based on the CTR human health criterion for waters from which both water and organisms are consumed. Based on receiving water salinity monitoring conducted by the Discharger, salinity in Humboldt Bay in the vicinity of the discharge exceeds the salinity threshold in Resolution No. 88-63. Therefore, this Order does not apply the MUN designation to Humboldt Bay and only the CTR human health criteria for waters from which organisms are consumed are applicable to the discharge. As shown in Table F-6 of this Fact Sheet, effluent monitoring data for dichlorobromomethane indicates that the discharge does not demonstrate reasonable potential to cause or contribute to an exceedance of the applicable CTR human health criterion. The updated effluent dichlorobromomethane data and the updated receiving water salinity data constitute new information, which permits the removal of effluent limitations consistent with CWA section 402(o)(2)(B). Therefore, this Order does not retain effluent limitations for dichlorobromomethane at Discharge Point 001.

Order No. R1-2012-0031 included effluent limitations for bis (2-ethylhexyl) phthalate at Discharge Points 001 and 003 based on the CTR human health criterion for waters from which both water and organisms are consumed. Based on receiving water salinity monitoring conducted by the Discharger, salinity in Humboldt Bay in the vicinity of the discharge exceeds the salinity threshold in Resolution No. 88-63. Therefore, this Order does not apply the MUN designation to Humboldt Bay and only the CTR human health criteria for waters from which organisms are consumed are applicable to the discharge. As shown in Table F-6 of this Fact Sheet, effluent monitoring data for bis (2-ethylhexyl) phthalate indicates that the discharge does not demonstrate reasonable potential to cause or contribute to an exceedance of the applicable CTR human health criterion. The updated effluent bis (2-ethylhexyl) phthalate data and the updated receiving water salinity data constitute new information, which permits the removal of effluent limitations consistent with CWA section 402(o)(2)(B). Therefore, this Order does not retain effluent limitations for bis (2-ethylhexyl) phthalate at Discharge Point 001 nor Discharge Point 003.

Order No. R1-2012-0031 included effluent limitations for TCDD-equivalents at Discharge Points 001 and 003 based on the CTR human health criterion for 2,3,7,8-TCDD, which is used to interpret the Basin Plan's narrative toxicity objective for TCDD-equivalents. This Order includes less stringent effluent limitations for TCDD-equivalents, which were calculated using an updated effluent monitoring data and a new CV. The updated effluent data used to calculate the CV constitutes new information that permits the relaxation of effluent limitations consistent with CWA section 402(o)(2)(B). Therefore, relaxation of the effluent limitations for TCDD-equivalents meets the exception in CWA section 402(o)(2)(B).

2. Antidegradation Policies

This Order is consistent with applicable federal and state antidegradation policies, as it does not authorize the discharge of increased concentrations of pollutants or increased volumes of treated wastewater beyond that which was permitted to discharge in accordance with Order No. R1-2012-0031.

3. Stringency of Requirements for Individual Pollutants

This Order contains both technology-based effluent limitations and WQBELs for individual pollutants. The technology-based effluent limitations consist of restrictions on BOD₅, pH, and TSS. Restrictions on these pollutants are discussed in section IV.B of this Fact Sheet. This Order's technology-based pollutant restrictions implement the minimum, applicable federal technology-based requirements. In addition, this Order contains effluent limitations for fecal coliform (Discharge Point 001, 002 and 3), pH, copper (Discharge Point 003 only), cyanide, TCDD-equivalents, ammonia, chlorine residual (Discharge Point 001 only), and settleable solids at Discharge Points 001 and 003, and effluent limitations for chlorine residual and settleable solids at Discharge Point 002, that are more stringent than the minimum, federal technology-based requirements but are necessary to meet water quality standards. These requirements are discussed in section IV.C.3 of the Fact Sheet.

WQBELs have been derived to implement water quality objectives that protect beneficial uses. Both the beneficial uses and the water quality objectives have been approved pursuant to federal law and are the applicable federal water quality standards. Most beneficial uses and water quality objectives contained in the Basin Plan were approved under state law and submitted to and approved by U.S. EPA prior to May 30, 2000. Any water quality objectives and beneficial uses submitted to U.S. EPA prior to May 30, 2000, but not approved by U.S. EPA before that date, are nonetheless "*applicable water quality standards for purposes of the CWA*" pursuant to 40 C.F.R. section 131.21(c)(1). Collectively, this Order's restrictions on individual pollutants are no more stringent than required to implement the requirements of the CWA.

The Regional Water Board has considered the factors in Water Code section 13263, including the provisions of Water Code section 13241, in establishing these requirements.

E. Interim Effluent Limitations – Not Applicable

This Order does not establish interim effluent limitations or schedules for compliance with final limitations.

F. Land Discharge Specifications and Requirements – Not Applicable

This Order does not authorize discharges to land.

G. Water Recycling Specifications and Requirements – Not Applicable

This Order does not authorize discharges of recycled water.

H. Other Requirements

- 1. Disinfection Process Requirements for Ultraviolet Light (UV) Disinfection System.** This Order contains monitoring requirements for the UV disinfection system in section IV.E.1. These requirements are needed to ensure that the disinfection process achieves effective pathogen reduction.

UV system operation requirements are necessary to ensure that adequate UV dosage is applied to the wastewater to inactivate pathogens (e.g., viruses, bacteria) in the wastewater. UV dosage is dependent on several factors such as UV transmittance, UV power setting, and wastewater flow through the UV system. Minimum dosage requirements are based on the Permittee's proposed design specifications for the UV disinfection system, which identify site-specific UV operating specifications for virus inactivation necessary to protect oyster growing areas within Humboldt Bay. Minimum UV dosage requirements specified in section IV.D.1 of the Order ensure that adequate disinfection of wastewater will be achieved.

V. RATIONALE FOR RECEIVING WATER LIMITATIONS

A. Surface Water

CWA section 303(a-c) requires states to adopt water quality standards, including criteria, where they are necessary to protect beneficial uses. The Regional Water Board adopted water quality criteria as water quality objectives in the Basin Plan.

The Basin Plan states that “[t]he numerical and narrative water quality objectives define the least stringent standards that the Regional [Water] Board will apply to regional waters in order to protect the beneficial uses.” The Basin Plan includes numeric and narrative water quality objectives for various beneficial uses and water bodies. This Order contains Receiving Surface Water Limitations based on the Basin Plan numerical and narrative water quality objectives for biostimulatory substances, bacteria, chemical constituents, color, dissolved oxygen, floating material, oil and grease, pH, pesticides, radioactivity, sediment, settleable material, suspended material, tastes and odors, temperature, toxicity, and turbidity.

The dissolved oxygen limitation in this Order reflects the new Basin Plan dissolved oxygen limit that was adopted by the Regional Water Board on June 18, 2015, and effective beginning April 24, 2017, after receiving approval from U.S. EPA. The new Basin Plan dissolved oxygen limitation specifies limits for the WARM, COLD, and SPWN beneficial uses. The COLD and SPWN beneficial uses occur in Humboldt Bay and its tributaries. This Order includes only the SPWN limitations because it is the most restrictive and protective limit and the SPWN beneficial use is present throughout the entire discharge season.

B. Groundwater

Groundwater limitations are included in this Order to protect the beneficial uses of the underlying groundwater. The beneficial uses of the underlying groundwater are municipal and domestic supply, industrial service supply, industrial process supply, agricultural supply, and freshwater replenishment to surface waters. Discharges from the Facility shall not cause exceedance of applicable water quality objectives or create adverse impacts to beneficial uses of groundwater. Groundwater data must be evaluated using appropriate statistical tools to determine when groundwater degradation is occurring.

The Basin Plan further requires that groundwaters shall not contain toxic substances in concentrations that are toxic to, or that produce detrimental physiological responses in humans, or that adversely affects beneficial uses. This limitation applies regardless of whether the toxicity is caused by a single substance or the synergistic effect of multiple substances.

VI. RATIONALE FOR PROVISIONS

A. Standard Provisions

1. Federal Standard Provisions

Standard Provisions, which apply to all NPDES permits in accordance with 40 C.F.R. section 122.41, and additional conditions applicable to specified categories of permits in accordance with 40 C.F.R. section 122.42, are provided in Attachment D to the Order. The Permittee must comply with all standard provisions and with those additional conditions that are applicable under 40 C.F.R. section 122.42. The rationale for the special conditions contained in the Order is provided in section VI.B, below.

Sections 122.41(a)(1) and (b) through (n) of 40 C.F.R. establish conditions that apply to all state-issued NPDES permits. These conditions must be incorporated into the permits either expressly or by reference. If incorporated by reference, a specific citation to the regulations must be included in the Order. Section 123.25(a)(12) allows the state to omit or modify conditions to impose more stringent requirements. In accordance with 40 C.F.R. section

123.25, this Order omits federal conditions that address enforcement authority specified in 40 C.F.R. sections 122.41(j)(5) and (k)(2) because the enforcement authority under the Water Code is more stringent. In lieu of these conditions, this Order incorporates by reference Water Code section 13387(e).

2. Regional Water Board Standard Provisions

In addition to the Federal Standard Provisions (Attachment D), the Permittee shall comply with the Regional Water Board Standard Provisions provided in Standard Provisions VI.A.2 of the Order.

- a. Order Provision VI.A.2.a identifies the state's enforcement authority under the Water Code, which is more stringent than the enforcement authority specified in the federal regulations (e.g., 40 C.F.R. sections 122.41(j)(5) and (k)(2)).
- b. Order Provision VI.A.2.b requires the Permittee to notify Regional Water Board staff, orally and in writing, in the event that the Permittee does not comply or will be unable to comply with any Order requirement. This provision requires the Permittee to make direct contact with a Regional Water Board staff person.

B. Special Provisions

1. Reopener Provisions

- a. **Standard Revisions (Special Provision VI.C.1.a).** Conditions that necessitate a major modification of a permit are described in 40 C.F.R. section 122.62, which include the following:
 - i. When standards or regulations on which the permit was based have been changed by promulgation of amended standards or regulations or by judicial decision. Therefore, if revisions of applicable water quality standards are promulgated or approved pursuant to section 303 of the CWA or amendments thereto, the Regional Water Board will revise and modify this Order in accordance with such revised standards.
 - ii. When new information that was not available at the time of permit issuance would have justified different permit conditions at the time of issuance.
- b. **Reasonable Potential (Special Provision VI.C.1.b).** This provision allows the Regional Water Board to modify, or revoke and reissue, this Order if present or future investigations demonstrate that the Permittee governed by this Permit is causing or contributing to excursions above any applicable CTR priority pollutant criterion or objective, or adversely impacting water quality and/or the beneficial uses of receiving waters.
- c. **Whole Effluent Toxicity (WET) (Special Provision VI.C.1.c).** This Order requires the Permittee to investigate the causes of, and identify corrective actions to reduce or eliminate effluent toxicity through a TRE. This Order may be reopened to include a numeric chronic toxicity limitation, new acute toxicity limitation, and/or a limitation for a specific toxicant identified in the TRE.
- d. **303(d)-Listed Pollutants (Special Provision VI.C.1.d).** This provision allows the Regional Water Board to reopen this Order to modify existing effluent limitations or add effluent limitations for pollutants that are the subject of any future TMDL action.
- e. **Water Effects Ratios (WERs) and Metal Translators (Special Provision VI.C.1.e).** This provision allows the Regional Water Board to reopen this Order if future studies undertaken by the Permittee provide new information and justification for applying a

WER or metal translator to a water quality objective for one or more CTR priority pollutants.

- f. Nutrients (Special Provision VI.C.1.f).** This Order contains effluent limitations for ammonia and effluent monitoring for nutrients (ammonia, nitrate, and phosphorus). This provision allows the Regional Water Board to reopen this Order if future monitoring data indicates the need for new or revised effluent limitations for any of these parameters.
- g. Ultraviolet Light (UV) Disinfection Operating Specifications (Special Provision VI.C.1.g).** UV system operating specifications are required to ensure that the UV system is operated to achieve the required pathogen removal. UV disinfection system specifications and monitoring and reporting requirements are required to ensure that adequate UV dosage is applied to the wastewater to inactivate pathogens (e.g., viruses) in the wastewater. UV dosage is dependent on several factors, such as UV transmittance, UV power setting, wastewater turbidity, and wastewater flow through the UV disinfection system. The UV specifications in this Order are based on the Permittee's proposed design specifications for the UV disinfection system, which identify site-specific UV operating specifications for virus inactivation necessary to protect oyster growing areas within Humboldt Bay. This provision allows the Regional Water Board to reopen this Order to modify the UV specifications if the Permittee conducts additional site-specific UV engineering studies that identify necessary revisions to the site-specific UV operating specifications necessary achieve the desired virus inactivation.

2. Special Studies and Additional Monitoring Requirements

- a. Arcata Marsh Wildlife Sanctuary (AMWS) Evaluation (Special Provision VI.C.2.a).** A special study is necessary to maintain an appropriate monitoring and reporting plan for the AMWS. The approved plan provides adequate evaluation of the health and performance of the AMWS and protects the applicable beneficial uses. The approved plan contains the following:
 - i.** Overall ecological condition of the AMWS using biological assessments;
 - ii.** Nutrient levels/enrichment of the AMWS, including but not limited to monitoring¹ for ammonia according to the schedule in the AMWS special study monitoring plan to determine natural cyclical loading from the AMWS;
 - iii.** Whether the AMWS condition is improving, degrading, or staying the same over time;
 - iv.** Seasonal patterns in AMWS conditions;
 - v.** Analysis of how increasing flows up to 5.9 mgd through the AMWS will impact water quality;
 - vi.** System stressors and associated thresholds (i.e., how much the AMWS system can be disturbed without causing unacceptable changes in wetland system quality or degradation of beneficial uses).
- b. Disaster Preparedness Assessment Report and Action Plan (Special Provision VI.C.2.b).** Natural disasters, extreme weather events, sea level rise, and shifting precipitation patterns, some of which are projected to intensify due to climate change, have significant implications for wastewater treatment and operations. Some natural

¹ The AMWS special study states that monitoring for ammonia shall occur at a minimum frequency of three times per month, no less than five days apart.

disasters are expected to become more frequent and extreme according to the current science on climate change. In order to ensure that Facility operations are not disrupted, compliance with conditions of this Order are achieved, and receiving waters are not adversely impacted by permitted and unpermitted discharges, this Order requires the Permittee to submit a Disaster Preparedness Assessment Report and Action Plan.

- c. **Source Control and Pretreatment Studies.** As discussed further in section VI.B.5.b of this Fact Sheet, this Order requires the Permittee to update its pretreatment program that conforms to Federal regulations. Thus, in order to prevent interference with the POTW or pass through of pollutants to the receiving water, this Order requires the Permittee to update their approved pretreatment program by conducting a local limits study and review and update, if necessary, their sewer use ordinances, legal authority, enforcement response plan and list of industrial users.

3. **Best Management Practices and Pollution Prevention**

- a. **Pollutant Minimization Program (Special Provision VI.C.3.a).** This provision is included in this Order pursuant to section 2.4.5 of the SIP. The Regional Water Board includes standard provisions in all NPDES permits requiring development of a Pollutant Minimization Program when there is evidence that a toxic pollutant is present in the effluent at a concentration greater than an applicable effluent limitation.

4. **Construction, Operation, and Maintenance Specifications**

- a. **Operation and Maintenance (Special Provisions VI.C.4.a and b).** 40 C.F.R. section 122.41(e) requires proper operation and maintenance of permitted wastewater systems and related facilities to achieve compliance with permit conditions. An up-to-date operation and maintenance manual, as required by Provision VI.C.4.b of this Order, is an integral part of a well-operated and maintained facility.

5. **Special Provisions for Municipal Facilities (POTWs Only)**

a. **Wastewater Collection Systems (Special Provision VI.C.5.a)**

- i. **Statewide General WDRs for Sanitary Sewer Systems.** On May 2, 2006, the State Water Board adopted General Waste Discharge Requirements for Sanitary Sewer Systems, Water Quality Order No. 2006-0003-DWQ (General Order). The General Order requires public agencies that own or operate sanitary sewer systems with greater than one mile of pipes or sewer lines to enroll for coverage under the General Order. The General Order requires agencies to develop sanitary system management plans (SSMPs) and report all SSOs, among other requirements and prohibitions.

On February 20, 2008, the State Water Board adopted Order No. WQ 2008-0002-EXEC Adopting Amended Monitoring and Reporting Requirements for Statewide General Waste Discharge Requirements for Sanitary Sewer Systems, to ensure adequate and timely notifications are made to the Regional Water Board and appropriate local, state, and federal authorities in case of sewage spills. On August 6, 2013, the State Water Board adopted Order No. WQ 2013-0058-EXEC Amending Monitoring and Reporting Program for Statewide General Waste Discharge Requirements for Sanitary Sewer Systems. Order No. WQ 2013-0058-EXEC addressed compliance and enforceability of the Monitoring and Reporting Program and superseded the amendments in Order No. WQ-2008-0002-EXEC. Notification and reporting of SSOs is conducted in accordance with the requirements of Order Nos. 2006-0003-DWQ and WQ 2013-0058-EXEC, and any revisions thereto for operation of its wastewater collection system.

- b. **Pretreatment of Industrial Waste (Special Provision VI.C.5.b).** Section 402(b)(8) of the CWA requires that POTWs receiving pollutants from significant industrial sources subject to section 307(b) standards establish an industrial pretreatment program to ensure compliance with these standards. The implementing regulations at 40 C.F.R. section 403.8(a) state, “any POTW (or combination of POTWs operated by the same authority) with a total design flow greater than 5 million gallons per day (mgd) and receiving from industrial users pollutants which pass through or interfere with operation of the POTW or are otherwise subject to pretreatment standards will be required to establish a POTW pretreatment program unless the NPDES State exercises its option to assume local responsibilities as provided in 403.10(e).” The Facility receives industrial wastewater from four non-categorical significant industrial users and two categorical industrial users and has a design treatment capacity greater than 5 mgd (peak wet weather treatment capacity of 5.9 mgd). Therefore, the Facility is subject to pretreatment standards as described in section 307(b) of the CWA and 40 C.F.R. section 403.8(a).
- c. **Sludge Disposal and Handling Requirements (Special Provision VI.C.5.c).** The disposal or reuse of wastewater treatment screenings, sludges, or other solids removed from the liquid waste stream is regulated by 40 C.F.R. parts 257, 258, 501, and 503, and the State Water Board promulgated provisions of title 27 of the CCR.
- d. **Operator Certification (Special Provision VI.C.5.d).** This provision requires the Facility to be operated by supervisors and operators who are certified as required by title 23, section 3680 of the CCR.
- e. **Adequate Capacity (Special Provision VI.C.5.e).** The goal of this provision is to ensure appropriate and timely planning by the Permittee to ensure adequate capacity for the protection of public health and water quality.

6. Other Special Provisions

- a. **Storm Water (Special Provision VI.C.6.a).** This provision requires the Permittee, if applicable, to obtain coverage under the State Water Board’s Water Quality Order No. 2014-0057-DWQ, NPDES General Permit No. CAS000001, General Permit for Storm Water Discharges Associated with Industrial Activities (or subsequent renewed versions of the NPDES General Permit CAS000001). Currently the Facility is exempted from these requirements because all storm water is captured and treated and/or disposed of within the Facility’s NPDES permitted process wastewater.

7. Compliance Schedules – Not Applicable

This Order does not establish interim effluent limitations or schedules of compliance for final numeric effluent limitations.

VII. RATIONALE FOR MONITORING AND REPORTING REQUIREMENTS

Section 122.48 of 40 C.F.R. requires that all NPDES permits specify requirements for recording and reporting monitoring results. Water Code section 13383 authorizes the Regional Water Board to require technical and monitoring reports. The MRP, Attachment E, establishes monitoring and reporting requirements that implement federal and state requirements. The following provides the rationale for the monitoring and reporting requirements contained in the MRP for this Facility.

A. Influent Monitoring

- 1. Influent monitoring requirements at Monitoring Location INF-001 for BOD₅ and TSS are retained from Order No. R1-2012-0031 and are necessary to determine compliance with the Order’s percent removal requirements for these parameters.

2. Influent monitoring requirements for flow at Monitoring Location INF-001 are retained from Order No. R1-2012-0031.

B. Effluent Monitoring

Effluent monitoring requirements are necessary to determine compliance with prohibitions and/or effluent limitations established by the Order. Monitoring at Monitoring Locations EFF-001, EFF-002, and EFF-003 is necessary to demonstrate compliance with effluent limitations and demonstrate whether or not the discharge poses reasonable potential for a pollutant to exceed any numeric or narrative water quality objectives.

1. Monitoring Location EFF-001

- a. Effluent monitoring frequencies and sample types for flow, BOD₅, fecal coliform, pH, TSS, cyanide, TCDD-equivalents, ammonia, chlorine residual, nitrate, and settleable solids at Monitoring Location EFF-001 have been retained from Order No. R1-2012-0031.
- b. Order No. R1-2012-0031 required monitoring for phosphorus “concurrent with the special study”, but did not specify the frequency. This Order establishes quarterly monitoring for phosphorus at Monitoring Location EFF-001 consistent with monitoring requirements for other nutrients (e.g., ammonia and nitrate) in the effluent.
- c. Effluent monitoring data collected during the term of Order No. R1-2012-0031 indicates that the discharge does not exhibit reasonable potential to cause or contribute to an exceedance of water quality objectives for bis (2-ethylhexyl) phthalate, carbon tetrachloride, or dichlorobromomethane. Therefore, this Order discontinues effluent monitoring requirements for bis (2-ethylhexyl) phthalate, carbon tetrachloride, and dichlorobromomethane at Monitoring Location EFF-001.
- d. This Order establishes weekly enterococci monitoring at Monitoring Location EFF-001 in order to determine compliance with applicable REC-1 bacteria provisions established in the *Water Quality Control Plan for Inland Surface Waters, Enclosed Bays and Estuaries (ISWEBE)*. The monitoring for enterococci has been delayed until the Permittee can attain ELAP accreditation for enterococci testing.
- e. Twice per permit term effluent monitoring for total mercury is accomplished with the priority pollutant scans required at Discharge Locations 001 and 003. The mercury monitoring established in this Order is to verify that the Subsistence Fishing (SUB) beneficial use is being protected and is consistent with the Statewide Mercury Provisions.

2. Monitoring Location EFF-002

- a. Effluent monitoring frequencies and sample types for flow, BOD₅, pH, TSS, and settleable solids at Monitoring Location EFF-002 have been retained from Order No. R1-2012-0031.
- b. This Order establishes weekly monitoring requirements for fecal coliform bacteria at Monitoring Location EFF-002 in order to determine compliance with applicable disinfection requirements immediately following the UV disinfection process.
- c. Order No. R1-2012-0031 established discharge specifications for chlorine residual at Discharge Point 002 but did not require compliance monitoring at Monitoring Location EFF-002. This Order establishes continuous monitoring requirements for chlorine residual at Monitoring Location EFF-002 to determine compliance with the applicable effluent limitations. Monitoring requirements for chlorine residual may be discontinued written certification that a chlorine-based disinfection system is no

longer in use for discharges through Discharge Point 002, chlorine byproducts are no longer present, and chlorine-containing chemicals are not added to the treatment process for wastewater discharged through Discharge Point 002.

- d. This Order establishes weekly enterococci monitoring at Monitoring Location EFF-002 in order to determine compliance with applicable REC-1 bacteria provisions established in the *Water Quality Control Plan for Inland Surface Waters, Enclosed Bays and Estuaries (ISWEBE)*. The monitoring for enterococci at EFF-002 will begin once the UV disinfection system is online. Monitoring for enterococci at EFF-002 shall start after Phase Two of the Proposed Upgrade Project is completed.

3. Monitoring Location EFF-003

- a. Effluent monitoring frequencies and sample types for flow, BOD₅, fecal coliform bacteria, pH, TSS, copper, cyanide, TCDD-equivalents, ammonia, hardness, nitrate, phosphorus, and settleable solids at Monitoring Location EFF-003 have been retained from Order No. R1-2012-0031.
- b. Effluent monitoring data collected during the term of Order No. R1-2012-0031 indicates that the discharge does not exhibit reasonable potential to cause or contribute to an exceedance of water quality objectives for bis (2-ethylhexyl) phthalate, carbon tetrachloride, or dichlorobromomethane. Therefore, this Order discontinues effluent monitoring requirements for bis (2-ethylhexyl) phthalate, carbon tetrachloride, and dichlorobromomethane at Monitoring Location EFF-003.
- c. Order No. R1-2012-0031 required continuous monitoring for chlorine residual at Monitoring Location EFF-003. The Permittee is planning to replace the existing chlorine disinfection system with a UV disinfection system. Discharges at Discharge Point 003 will not commence until completion of the UV disinfection system. As a result, discharges at Discharge Point 003 are not expected to contain chlorine residual. Therefore, this Order discontinues effluent monitoring for chlorine residual.
- d. Order No. R1-2012-0031 required monitoring for phosphorus “concurrent with the special study”, but did not specify the frequency. This Order establishes quarterly monitoring for phosphorus at Monitoring Location EFF-003 consistent with monitoring requirements for other nutrients (e.g., ammonia and nitrate) in the effluent.
- e. Order No. R1-2012-0031 required annual effluent monitoring for CTR priority pollutants. This Order requires effluent monitoring for CTR priority pollutants twice per permit term in order to generate adequate data to perform an RPA. Monitoring for CTR priority pollutants shall be conducted at Monitoring Location EFF-003. The sample type has been changed from grab to 24-hour composite for CTR priority pollutants, with the exception of those CTR priority pollutants that are volatile.
- f. This Order eliminates the effluent monitoring requirement for title 22 pollutants since monitoring during the previous permit term demonstrated that no title 22 pollutants exhibited reasonable potential to exceed applicable water quality objectives.

C. Whole Effluent Toxicity Testing Requirements

WET monitoring requirements are retained from Order No. R1-2012-0031 and are included in this Order to protect the receiving water quality from the aggregate effect of a mixture of pollutants in the effluent. Acute toxicity testing measures mortality in 100 percent effluent over a short test period and chronic toxicity testing is conducted over a longer time period and may measure mortality, reproduction, and/or growth.

In addition to routine toxicity monitoring, this Order requires the Permittee to maintain and update their TRE Work Plan, in accordance with appropriate U.S. EPA guidance, to ensure that the Permittee has a plan to immediately move forward with the initial tiers of a TRE in the event effluent toxicity is encountered in the future. The TRE is initiated by evidence of a pattern of toxicity demonstrated through the additional effluent monitoring provided as a result of an accelerated monitoring program.

D. Receiving Water Monitoring

1. Surface Water

- a. Receiving water monitoring is required to demonstrate compliance with the Receiving Water Limitations. Monitoring requirements at Monitoring Location RSW-001 for pH, dissolved oxygen, floatables/discoloration, specific conductance, hardness, nitrate, salinity, temperature, total dissolved solids, turbidity, and CTR priority pollutants have been retained from Order No. R1-2012-0031.

2. Groundwater – Not Required

This Order does not require groundwater monitoring at this time.

E. Other Monitoring Requirements

1. **Disinfection Process Monitoring for UV Disinfection System.** UV disinfection system monitoring requirements at Monitoring Location INT-001 are included to assess compliance of the UV disinfection system with the NWRI Guidelines.
2. **Visual Monitoring.** This Order establishes visual monitoring requirements for the effluent (Monitoring Locations EFF-001, EFF-002 and EFF-003) and receiving water (Monitoring Locations RSW-001) to ensure compliance with receiving water limitations in section V of the Order.
3. **Biosolids Monitoring.** The Permittee monitors biosolids and reports biosolids application practices under requirements in the Biosolids General Order No. 20004-0012-DWQ.
4. **Discharge Monitoring Report Quality Assurance (DMR-QA) Study Program.** Under the authority of section 308 of the CWA (33 U.S.C. § 1318), U.S. EPA requires all permittees under the NPDES Program to participate in the annual DMR-QA Study Program. The DMR-QA Study evaluates the analytical ability of laboratories that routinely perform or support self-monitoring analyses required by NPDES permits. There are two options to satisfy the requirements of the DMR-QA Study Program: (1) The Permittee can obtain and analyze a DMR-QA sample as part of the DMR-QA Study; or (2) Per the waiver issued by U.S. EPA to the State Water Board, the Permittee can submit the results of the most recent Water Pollution Performance Evaluation Study from its own laboratories or its contract laboratories. A Water Pollution Performance Evaluation Study is similar to the DMR-QA Study. Thus, it also evaluates a laboratory's ability to analyze wastewater samples to produce quality data that ensure the integrity of the NPDES Program. The Permittee shall ensure that the results of the DMR-QA Study or the results of the most recent Water Pollution Performance Evaluation Study are submitted annually to the State Water Board. The State Water Board's Quality Assurance Program Officer will send the DMR-QA Study results or the results of the most recent Water Pollution Performance Evaluation Study to U.S. EPA's DMR-QA Coordinator and Quality Assurance Manager.
5. **Accelerated Monitoring Requirements.** Tables E-2, E-3, and E-4 of the MRP include accelerated monitoring requirements for parameters that are required to be monitored daily, weekly, monthly, and annually.

6. **Flow Monitoring.** Section I.D of the MRP requires proper installation, calibration, operation, and maintenance of flow metering devices.
7. **Spill Notification.** The MRP that is part of this Order establishes requirements for reporting spills and unauthorized discharges, with the exception of SSOs, which must be reported in accordance with the requirements of State Water Board Order No. 2006-0003-DWQ and WQ-2013-0058-EXEC.

VIII. PUBLIC PARTICIPATION

The Regional Water Board is considering the issuance of WDRs that will serve as a NPDES permit for the City of Arcata Wastewater Treatment Facility. As a step in the WDR adoption process, the Regional Water Board staff has developed tentative WDRs. The Regional Water Board encourages public participation in the WDR adoption process.

A. Notification of Interested Parties

The Regional Water Board notified the Permittee and interested agencies and persons of its intent to prescribe WDRs for the discharge and provided an opportunity to submit written comments and recommendations. Notification was provided through the following posting on the Regional Water Board's Internet site at:

http://www.waterboards.ca.gov/northcoast/public_notices/public_hearings/npdes_permits_and_wdrs.shtml and through publication in the **Eureka Time Standard and the Santa Rosa Press Democrat on January 4, 2019.**

B. Written Comments

Interested persons were invited to submit written comments concerning these tentative WDRs as provided through the notification process. Comments were due to the Regional Water Board Executive Office electronically via e-mail to NorthCoast@waterboards.ca.gov or on disk (CD or DCD) in Portable Document Format (PDF) file in lieu of paper-sourced documents. The guidelines for electronic submittal of documents can be found on the Regional Water Board website at <http://www.waterboards.ca.gov/northcoast>.

To be fully responded to by staff and considered by the Regional Water Board, the written comments were due at the Regional Water Board office by 5:00 p.m. on **February 4, 2019.**

C. Public Hearing

The Regional Water Board held a public hearing on the draft WDRs during its regular Board meeting on the following date and time and at the following location:

Date: **October 17**
Time: 8:30 a.m. or as announced in the Regional Water Board's agenda
Location: Regional Water Board Hearing Room
5550 Skylane Boulevard, Suite A
Santa Rosa, CA 95403

Interested persons were invited to attend. At the public hearing, the Regional Water Board heard testimony pertinent to the discharge, WDRs, and permit. For accuracy of the record, important testimony was requested in writing.

Please be aware that dates and venues may change. Our Web address is <http://www.waterboards.ca.gov/northcoast> where you can access the current agenda for changes in dates and locations.

D. Waste Discharge Requirements Petitions

Any aggrieved person may petition the State Water Board to review the decision of the Regional Water Board regarding the final WDRs. The petition must be received by the State Water Board at the following address within 30 calendar days of the Regional Water Board's action:

State Water Resources Control Board
Office of Chief Counsel
P.O. Box 100, 1001 I Street
Sacramento, CA 95812-0100

For instruction on how to file a petition for review see

http://www.waterboards.ca.gov/public_notices/petitions/water_quality/wqpetition_instr.shtml

E. Information and Copying

The ROWD, related documents, tentative effluent limitations and special provisions, comments received, and other information are on file and may be inspected at the address identified in section VIII.C, above, at any time between 8:30 a.m. and 4:45 p.m., Monday through Friday. Copying of documents may be arranged through the Regional Water Board by calling (707) 576-2220.

F. Register of Interested Persons

Any person interested in being placed on the mailing list for information regarding the WDRs and NPDES permit should contact the Regional Water Board, reference this facility, and provide a name, address, and phone number.

G. Additional Information

Requests for additional information or questions regarding this order should be directed to Justin McSmith at Justin.McSmith@waterboards.ca.gov or (707) 576-2082.

Attachment F-1 - City of Arcata RPA Summary

Constituent	Units	Qualifier	MEC	Qualifier	B	C	CMC ¹	CCC ¹	CMC ²	CCC ²	Water & Org	Org. Only	MCL	Reasonable Potential
Antimony	µg/L	J	2.7	--	--	4,300	--	--	--	--	--	4,300	--	No
Arsenic	µg/L	=	1.3	--	--	36	340	150	69	36	--	--	--	No
Beryllium	µg/L	<	0.10	--	--	No Criteria	--	--	--	--	--	--	--	No
Cadmium	µg/L	=	0.34	--	--	7.3	22	7.3	42	9.4	--	--	--	No
Chromium (III)	µg/L	J	0.56	--	--	644	5,400	640			--	--	--	No
Chromium (VI)	µg/L	=	6.4	--	--	11	16	11	1,100	50	--	--	--	No
Copper	µg/L	=	7.6	--	--	21.5	300 ³	180 ³	33 ³	22 ³	--	--	--	No
Copper	µg/L	=	7.6	--	--	3.7	52 ⁴	31 ⁴	5.8 ⁴	3.7 ⁴	--	--	--	Yes
Lead	µg/L	<	0.23	--	--	8.5	480	19	220	8.5	--	--	--	No
Mercury	µg/L	=	0.00368	--	--	0.051	--	--	--	--	--	0.051	--	No
Nickel	µg/L	=	3.9	--	--	8.3	1,500	170	75	8.3	--	4,600	--	No
Selenium	µg/L	J	1.1	--	--	5.0	--	5.0	291	71	--	--	--	No
Silver	µg/L	<	0.15	--	--	2.2	44	--	2.2	--	--	--	--	No
Thallium	µg/L	J	0.23	--	--	6.3	--	--	--	--	--	6.3	--	No
Zinc	µg/L	J	7.2	--	--	86	390	390	95	86	--	--	--	No
Cyanide	µg/L	=	7.0	--	--	1.0	22	5.2	1.0	1.0	--	220,000	--	Yes
Asbestos	MFL	<	0.21	--	--	No Criteria	--	--	--	--	--	--	--	No
2,3,7,8 TCDD	µg/L	<	1.32 x 10 ⁻⁷	--	--	1.4 x 10 ⁻⁸	--	--	--	--	--	1.4 x 10 ⁻⁸	--	No
TCDD-equivalents	µg/L	=	2.85 x 10 ⁻⁷	--	--	1.4 x 10 ⁻⁸	--	--	--	--	--	1.4 x 10 ⁻⁸	--	Yes
Acrolein	µg/L	<	1.0	--	--	780	--	--	--	--	--	780	--	No
Acrylonitrile	µg/L	<	1.6	--	--	0.66	--	--	--	--	--	0.66	--	No
Benzene	µg/L	<	0.057	--	--	71	--	--	--	--	--	71	--	No
Bromoform	µg/L	<	0.10	--	--	360	--	--	--	--	--	360	--	No
Carbon Tetrachloride	µg/L	=	0.80	--	--	4.4	--	--	--	--	--	4.4	--	No
Chlorobenzene	µg/L	<	0.053	--	--	21,000	--	--	--	--	--	21,000	--	No
Chlorodibromomethane	µg/L	=	1.3	--	--	34	--	--	--	--	--	34	--	No
Chloroethane	µg/L	<	0.098	--	--	No Criteria	--	--	--	--	--	--	--	No
2-Chloroethylvinyl ether	µg/L	<	0.087	--	--	No Criteria	--	--	--	--	--	--	--	No
Chloroform	µg/L	=	13	--	--	No Criteria	--	--	--	--	--	--	--	No
Dichlorobromomethane	µg/L	=	5.7	--	--	46	--	--	--	--	--	46	--	No
1,1-Dichloroethane	µg/L	<	0.061	--	--	No Criteria	--	--	--	--	--	--	--	No
1,2-Dichloroethane	µg/L	<	0.054	--	--	99	--	--	--	--	--	99	--	No
1,1-Dichloroethylene	µg/L	<	0.092	--	--	3.2	--	--	--	--	--	3.2	--	No
1,2-Dichloropropane	µg/L	<	0.057	--	--	39	--	--	--	--	--	39	--	No

Constituent	Units	Qualifier	MEC	Qualifier	B	C	CMC ¹	CCC ¹	CMC ²	CCC ²	Water & Org	Org. Only	MCL	Reasonable Potential
1,3-Dichloropropylene	µg/L	<	0.041	--	--	1,700	--	--	--	--	--	1,700	--	No
Ethylbenzene	µg/L	<	0.074	--	--	29,000	--	--	--	--	--	29,000	--	No
Methyl Bromide	µg/L	<	0.054	--	--	4,000	--	--	--	--	--	4,000	--	No
Methyl Chloride	µg/L	<	0.092	--	--	No Criteria	--	--	--	--	--	--	--	No
Methylene Chloride	µg/L	<	0.066	--	--	16,000	--	--	--	--	--	16,000	--	No
1,1,2,2-Tetrachloroethane	µg/L	<	0.13	--	--	11	--	--	--	--	--	11	--	No
Tetrachloroethylene	µg/L	<	0.086	--	--	8085	--	--	--	--	--	8,085	--	No
Toluene	µg/L	J	0.29	--	--	200,000	--	--	--	--	--	200,000	--	No
1,2-Trans-Dichloroethylene	µg/L	<	0.072	--	--	140,000	--	--	--	--	--	140,000	--	No
1,1,1-Trichloroethane	µg/L	<	0.086	--	--	No Criteria	--	--	--	--	--	--	--	No
1,1,2-Trichloroethane	µg/L	<	0.057	--	--	42	--	--	--	--	--	42	--	No
Trichloroethylene	µg/L	<	0.11	--	--	81	--	--	--	--	--	81	--	No
Vinyl Chloride	µg/L	<	0.11	--	--	525	--	--	--	--	--	525	--	No
2-Chlorophenol	µg/L	<	0.53	--	--	400	--	--	--	--	--	400	--	No
2,4-Dichlorophenol	µg/L	<	0.70	--	--	790	--	--	--	--	--	790	--	No
2,4-Dimethylphenol	µg/L	<	0.59	--	--	2,300	--	--	--	--	--	2,300	--	No
2-Methyl- 4,6-Dinitrophenol	µg/L	<	0.74	--	--	765	--	--	--	--	--	765	--	No
2,4-Dinitrophenol	µg/L	<	0.51	--	--	14,000	--	--	--	--	--	14,000	--	No
2-Nitrophenol	µg/L	<	0.50	--	--	No Criteria	--	--	--	--	--	--	--	No
4-Nitrophenol	µg/L	<	0.55	--	--	No Criteria	--	--	--	--	--	--	--	No
3-Methyl 4-Chlorophenol	µg/L	<	0.67	--	--	No Criteria	--	--	--	--	--	--	--	No
Pentachlorophenol	µg/L	<	0.97	--	--	7.9	12	9.0	13	7.9	--	8.2	--	No
Phenol	µg/L	J	2.1	--	--	4,600,000	--	--	--	--	--	4,600,000	--	No
2,4,6-Trichlorophenol	µg/L	<	0.71	--	--	6.5	--	--	--	--	--	6.5	--	No
Acenaphthene	µg/L	<	0.011	--	--	2,700	--	--	--	--	--	2,700	--	No
Acenaphthylene	µg/L	<	0.011	--	--	No Criteria	--	--	--	--	--	--	--	No
Anthracene	µg/L	<	0.0072	--	--	110,000	--	--	--	--	--	110,000	--	No
Benzidine	µg/L	<	0.5	--	--	0.00054	--	--	--	--	--	0.00054	--	No
Benzo(a)Anthracene	µg/L	<	0.0098	--	--	0.049	--	--	--	--	--	0.049	--	No
Benzo(a)Pyrene	µg/L	<	0.01	--	--	0.049	--	--	--	--	--	0.049	--	No
Benzo(b)Fluoranthene	µg/L	<	0.015	--	--	0.049	--	--	--	--	--	0.049	--	No
Benzo(ghi)Perylene	µg/L	<	0.023	--	--	No Criteria	--	--	--	--	--	--	--	No
Benzo(k)Fluoranthene	µg/L	<	0.011	--	--	0.049	--	--	--	--	--	0.049	--	No

Constituent	Units	Qualifier	MEC	Qualifier	B	C	CMC ¹	CCC ¹	CMC ²	CCC ²	Water & Org	Org. Only	MCL	Reasonable Potential
Bis(2-Chloroethoxy) methane	µg/L	<	0.55	--	--	No Criteria	--	--	--	--	--	--	--	No
Bis(2-Chloroethyl) Ether	µg/L	<	0.50	--	--	1.4	--	--	--	--	--	1.4	--	No
Bis(2-Chloroisopropyl) ether	µg/L	<	0.50	--	--	170,000	--	--	--	--	--	170,000	--	No
Bis(2-Ethylhexyl) phthalate	µg/L	=	2.8	--	--	5.9	--	--	--	--	--	5.9	--	No
4-Bromophenyl Phenyl Ether	µg/L	<	0.50	--	--	No Criteria	--	--	--	--	--	--	--	No
Butylbenzyl Phthalate	µg/L	<	1.2	--	--	5,200	--	--	--	--	--	5,200	--	No
2-Chloronaphthalene	µg/L	<	0.50	--	--	4,300	--	--	--	--	--	4,300	--	No
4-Chlorophenyl Phenyl Ether	µg/L	<	0.50	--	--	No Criteria	--	--	--	--	--	--	--	No
Chrysene	µg/L	<	0.0092	--	--	0.049	--	--	--	--	--	0.049	--	No
Dibenzo(a,h) Anthracene	µg/L	<	0.023	--	--	0.049	--	--	--	--	--	0.049	--	No
1,2-Dichlorobenzene	µg/L	<	0.040	--	--	17,000	--	--	--	--	--	17,000	--	No
1,3-Dichlorobenzene	µg/L	<	0.047	--	--	2,600	--	--	--	--	--	2,600	--	No
1,4-Dichlorobenzene	µg/L	<	0.044	--	--	2,600	--	--	--	--	--	2,600	--	No
3,3 Dichlorobenzidine	µg/L	<	0.50	--	--	0.077	--	--	--	--	--	0.077	--	No
Diethyl Phthalate	µg/L	<	0.54	--	--	120,000	--	--	--	--	--	120,000	--	No
Dimethyl Phthalate	µg/L	<	1.1	--	--	2,900,000	--	--	--	--	--	2,900,000	--	No
Di-n-Butyl Phthalate	µg/L	<	0.73	--	--	12,000	--	--	--	--	--	12,000	--	No
2,4-Dinitrotoluene	µg/L	<	0.59	--	--	9.1	--	--	--	--	--	9.1	--	No
2,6-Dinitrotoluene	µg/L	<	0.71	--	--	No Criteria	--	--	--	--	--	--	--	No
Di-n-Octyl Phthalate	µg/L	<	0.72	--	--	No Criteria	--	--	--	--	--	--	--	No
1,2-Diphenylhydrazine	µg/L	<	0.50	--	--	0.54	--	--	--	--	--	0.54	--	No
Fluoranthene	µg/L	<	0.0096	--	--	370	--	--	--	--	--	370	--	No
Fluorene	µg/L	<	0.016	--	--	14,000	--	--	--	--	--	14,000	--	No
Hexachlorobenzene	µg/L	<	0.0070	--	--	0.00077	--	--	--	--	--	0.00077	--	No
Hexachlorobutadiene	µg/L	<	0.084	--	--	50	--	--	--	--	--	50	--	No
Hexachlorocyclopentadiene	µg/L	<	0.50	--	--	17,000	--	--	--	--	--	17,000	--	No
Hexachloroethane	µg/L	<	0.50	--	--	8.9	--	--	--	--	--	8.9	--	No
Indeno(1,2,3-cd) Pyrene	µg/L	<	0.016	--	--	0.049	--	--	--	--	--	0.049	--	No
Isophorone	µg/L	<	0.55	--	--	600	--	--	--	--	--	600	--	No
Naphthalene	µg/L	J	0.047	--	--	No Criteria	--	--	--	--	--	--	--	No
Nitrobenzene	µg/L	<	0.52	--	--	1,900	--	--	--	--	--	1,900	--	No
N-Nitrosodimethylamine	µg/L	<	0.47	--	--	8.1	--	--	--	--	--	8.1	--	No
N-Nitrosodi-n-Propylamine	µg/L	<	0.50	--	--	1.4	--	--	--	--	--	1.4	--	No
N-Nitrosodiphenylamine	µg/L	<	0.71	--	--	16	--	--	--	--	--	16	--	No

Constituent	Units	Qualifier	MEC	Qualifier	B	C	CMC ¹	CCC ¹	CMC ²	CCC ²	Water & Org	Org. Only	MCL	Reasonable Potential
Phenanthrene	µg/L	<	0.012	--	--	No Criteria	--	--	--	--	--	--	--	No
Pyrene	µg/L	<	0.033	--	--	11,000	--	--	--	--	--	11,000	--	No
1,2,4-Trichlorobenzene	µg/L	<	0.040	--	--	No Criteria	--	--	--	--	--	--	--	No
Aldrin	µg/L	<	0.0016	--	--	0.00014	3.0	--	1.3	--	--	0.00014	--	No
alpha-BHC	µg/L	<	0.0016	--	--	0.013	--	--	--	--	--	0.013	--	No
beta-BHC	µg/L	<	0.0018	--	--	0.046	--	--	--	--	--	0.046	--	No
gamma-BHC	µg/L	<	0.0014	--	--	0.063	0.95	--	0.16	--	--	0.063	--	No
delta-BHC	µg/L	<	0.0014	--	--	No Criteria	--	--	--	--	--	--	--	No
Chlordane	µg/L	<	0.034	--	--	0.00059	2.4	0.0043	0.09	0.004	--	0.00059	--	No
4,4'-DDT	µg/L	<	0.0010	--	--	0.00059	1.1	0.001	0.13	0.001	--	0.00059	--	No
4,4'-DDE	µg/L	<	0.0020	--	--	0.00059	--	--	--	--	--	0.00059	--	No
4,4'-DDD	µg/L	<	0.0099	--	--	0.00084	--	--	--	--	--	0.00084	--	No
Dieldrin	µg/L	<	0.0018	--	--	0.00014	0.24	0.056	0.71	0.0019	--	0.00014	--	No
alpha-Endosulfan	µg/L	<	0.0017	--	--	0.00087	0.22	0.056	0.034	0.0087	--	240	--	No
beta-Endosulfan	µg/L	<	0.00092	--	--	0.00087	0.22	0.056	0.034	0.0087	--	240	--	No
Endosulfan Sulfate	µg/L	<	0.0023	--	--	240	--	--	--	--	--	240	--	No
Endrin	µg/L	<	0.0019	--	--	0.0023	0.086	0.036	0.037	0.0023	--	0.81	--	No
Endrin Aldehyde	µg/L	<	0.0020	--	--	0.81	--	--	--	--	--	0.81	--	No
Heptachlor	µg/L	<	0.0018	--	--	0.00021	0.52	0.0038	0.053	0.0036	--	0.00021	--	No
Heptachlor Epoxide	µg/L	<	0.0015	--	--	0.00011	0.52	0.0038	0.053	0.0036	--	0.00011	--	No
PCBs sum	µg/L	<	0.0010	--	--	0.00017	--	0.014	--	0.030	--	0.00017	--	No
Toxaphene	µg/L	<	0.052	--	--	0.00020	0.73	0.0002	0.21	0.0002	--	0.00075	--	No
Ammonia Nitrogen, Total (as N)	mg/L	=	18	--	--	0.29	2.59	1.44	1.90	0.29	--	--	--	Yes
Nitrate, Total (as N)	mg/L	=	2.7	--	--	No Criteria	--	--	--	--	--	--	--	No

Table Notes:

1. Water quality criteria for the protection of freshwater aquatic life.
2. Water quality criteria for the protection of saltwater aquatic life.
3. Water quality criteria calculated using a WER of 5.76 for Discharge Point 001.
4. Water quality criteria calculated using default WER of 1.0 for Discharge Point 003.

ATTACHMENT G - AMEL AND MDEL AMMONIA STANDARDS BASED ON THE 1989 SALTWATER ACUTE CRITERIA

Table 1: pH, Salinity and Temperature Dependent AMEL Ammonia Criteria

	Temperature, °C							
pH	0	5	10	15	20	25	30	35
	Salinity = 10 g/kg							
7.0	30	21	15	10	6.9	4.8	3.2	2.3
7.2	19	13	8.8	6.4	4.3	3.0	2.0	1.5
7.4	12	8.8	5.7	3.9	2.7	1.9	1.3	0.88
7.6	7.3	5.3	3.7	2.5	1.8	1.2	0.88	0.61
7.8	4.8	3.4	2.3	1.6	1.1	0.80	0.55	0.39
8.0	3.0	2.1	1.5	1.0	0.71	0.50	0.34	0.25
8.2	2.0	1.3	1.0	0.64	0.45	0.32	0.23	0.17
8.4	1.2	0.88	0.59	0.41	0.30	0.21	0.15	0.12
8.6	0.80	0.55	0.39	0.27	0.20	0.15	0.11	0.08
8.8	0.50	0.37	0.25	0.18	0.13	0.10	0.08	0.06
9.0	0.32	0.23	0.17	0.12	0.10	0.07	0.06	0.05
	Salinity = 20 g/kg							
7.0	32	22	15	10	7.1	4.8	3.4	2.3
7.2	20	14	9.5	6.6	4.5	3.2	2.2	1.5
7.4	13	8.8	5.9	4.1	3.0	2.0	1.4	0.95
7.6	8.0	5.5	3.9	2.5	1.8	1.2	0.88	0.61
7.8	5.0	3.4	2.5	1.7	1.2	0.80	0.57	0.39
8.0	3.2	2.2	1.5	1.1	0.73	0.53	0.37	0.25
8.2	2.0	1.4	0.95	0.69	0.48	0.34	0.23	0.18
8.4	1.3	0.88	0.61	0.43	0.32	0.22	0.16	0.12
8.6	0.80	0.57	0.41	0.30	0.20	0.15	0.11	0.09
8.8	0.53	0.37	0.27	0.19	0.14	0.10	0.08	0.06
9.0	0.34	0.25	0.18	0.13	0.10	0.07	0.06	0.05
	Salinity = 30 g/kg							
7.0	34	23	16	11	8.0	5.3	3.7	2.5
7.2	21	15	10	7.1	4.8	3.4	2.3	1.6
7.4	14	9.5	6.4	4.1	3.0	2.1	1.5	1.0
7.6	8.8	5.9	4.1	2.7	2.3	1.3	0.95	0.66
7.8	5.5	3.7	2.5	1.8	1.2	0.88	0.59	0.41
8.0	3.4	2.3	1.6	1.2	0.80	0.55	0.39	0.27
8.2	2.2	1.5	1.0	0.73	0.50	0.37	0.25	0.18
8.4	1.4	0.95	0.66	0.45	0.32	0.23	0.17	0.12

8.6	0.88	0.61	0.43	0.30	0.22	0.16	0.12	0.09
8.8	0.57	0.39	0.27	0.20	0.15	0.11	0.08	0.07
9.0	0.37	0.25	0.19	0.14	0.10	0.08	0.06	0.05

Table 2: pH, Salinity and Temperature Dependent MDEL Ammonia Criteria

pH	Temperature, °C							
	0	5	10	15	20	25	30	35
Salinity = 10 g/kg								
7.0	75	53	36	25	17	12	8.0	5.6
7.2	47	33	22	16	11	7.5	5.1	3.6
7.4	31	22	14	9.6	6.7	4.7	3.3	2.2
7.6	18	13	9.1	6.2	4.4	3.1	2.2	1.5
7.8	12	8.6	5.6	4.0	2.7	2.0	1.4	0.96
8.0	7.5	5.3	3.6	2.5	1.8	1.3	0.86	0.62
8.2	4.9	3.3	2.4	1.6	1.1	0.80	0.56	0.42
8.4	3.1	2.2	1.5	1.0	0.75	0.53	0.38	0.29
8.6	2.0	1.4	0.96	0.67	0.49	0.36	0.27	0.20
8.8	1.3	0.91	0.62	0.46	0.33	0.25	0.20	0.15
9.0	0.80	0.56	0.42	0.31	0.24	0.18	0.15	0.13
Salinity = 20 g/kg								
7.0	80	55	38	25	18	12	8.6	5.6
7.2	49	35	24	16	11	8.0	5.5	3.8
7.4	33	22	15	10	7.5	4.9	3.5	2.4
7.6	20	14	10	6.2	4.6	3.1	2.2	1.5
7.8	13	8.6	6.2	4.2	2.9	2.0	1.4	0.96
8.0	8.0	5.5	3.8	2.7	1.8	1.3	0.91	0.62
8.2	5.1	3.5	2.4	1.7	1.2	0.86	0.56	0.44
8.4	3.3	2.2	1.5	1.1	0.80	0.55	0.40	0.29
8.6	2.0	1.4	1.0	0.75	0.51	0.36	0.27	0.22
8.8	1.3	0.91	0.67	0.47	0.35	0.25	0.20	0.15
9.0	0.86	0.62	0.44	0.33	0.24	0.18	0.15	0.13
Salinity = 30 g/kg								
7.0	86	56	40	27	20	13	9.1	6.2
7.2	53	36	25	18	12	8.6	5.6	4.0
7.4	35	24	16	10	7.5	5.3	3.6	2.5
7.6	22	15	10	6.7	5.6	3.3	2.4	1.6
7.8	14	9.1	6.2	4.4	3.1	2.2	1.5	1.0
8.0	8.6	5.6	4.0	2.9	2.0	1.4	0.96	0.67
8.2	5.5	3.8	2.5	1.8	1.3	0.91	0.62	0.46

8.4	3.5	2.4	1.6	1.1	0.80	0.56	0.42	0.31
8.6	2.2	1.5	1.1	0.75	0.55	0.40	0.29	0.22
8.8	1.4	0.96	0.67	0.49	0.36	0.27	0.20	0.16
9.0	0.91	0.62	0.47	0.35	0.25	0.20	0.15	0.13

ATTACHMENT H - PDF EXAMPLE OF THE AIR CALCULATOR

A	B	C	D	E	F	G	H
Date of Sample	Ammonia Value in Effluent (mg/L N)	Receiving Water pH	Receiving Water Temperature (°C)	Receiving Water Salinity (g/kg)	Ammonia Standard as determined from Ammonia Criteria Tables	MDEL Ammonia Impact Ratio (Column B/Column F)	AMEL Ammonia Impact Ratio (Column B/Column F)