

**CALIFORNIA REGIONAL WATER QUALITY CONTROL BOARD  
CENTRAL COAST REGION**

895 Aerovista Place, Suite 101  
San Luis Obispo, CA 93401  
<http://www.waterboards.ca.gov/centralcoast>

**DRAFT ORDER NO. R3-2017-0049  
NPDES NO. CA0001465  
WASTE DISCHARGE REQUIREMENTS  
FOR THE CHEVRON ESTERO MARINE TERMINAL**

The following Discharger is subject to waste discharge requirements as set forth in this Order.

**Table 1. Discharger Information**

<b>Discharger</b>	Chevron Environmental Management Company
<b>Name of Facility</b>	Chevron Estero Marine Terminal
<b>Facility Address</b>	4000 Highway One
	Morro Bay, CA 93442
	San Luis Obispo County

Discharges by the Chevron Estero Marine Terminal from the discharge points identified below are subject to waste discharge requirements as set forth in this Order.

**Table 2. Discharge Location**

<b>Discharge Point</b>	<b>Effluent Description</b>	<b>Discharge Point Latitude</b>	<b>Discharge Point Longitude</b>	<b>Receiving Water</b>
001	Treated Groundwater	35° 24' 25" N	120° 53' 05" W	Pacific Ocean

**Table 3. Administrative Information**

This Order was adopted on:	<b>December 7, 2017</b>
This Order shall become effective on:	<b>January 26, 2018</b>
This Order shall expire on:	<b>January 25, 2023</b>
The Discharger shall file a Report of Waste Discharge in accordance with title 23, California Code of Regulations, as application for issuance of new waste discharge requirements no later than:	<b>July 29, 2022</b>
The U.S. Environmental Protection Agency (USEPA) and the Central Coast Water Board have classified this discharge as follows:	<b>Minor</b>

IT IS HEREBY ORDERED, that Order No. R3-2011-0219 is rescinded upon the effective date of this Order except for enforcement purposes and, in order to meet the provisions contained in division 7 of the California Water Code (commencing with section 13000) and regulations adopted thereunder and the provisions of the federal Clean Water Act (CWA) and regulations and guidelines adopted thereunder, the Discharger shall comply with the requirements in this Order.

I, John Robertson, Executive Officer, do hereby certify that this Order, with all attachments, is a full, true, and correct copy of an order adopted by the California Regional Water Quality Control Board, Central Coastal Region on the date indicated above.

\_\_\_\_\_  
John M. Robertson, Executive Officer

**Table of Contents**

I. Facility Information ..... 4  
 II. Findings..... 4  
 III. Discharge Prohibitions..... 9  
 IV. Effluent Limitations and Discharge Specifications ..... 9  
     A. Effluent Limitations – Discharge Point No. 001 ..... 9  
     B. Interim Effluent Limitations – Not Applicable..... 13  
     C. Land Discharge Effluent Limitations and Specifications – Not Applicable..... 13  
     D. Reclamation Specifications – Not Applicable..... 13  
 V. Receiving Water Limitations ..... 13  
     A. Surface Water Limitations for Discharge Point No. 001 (Pacific Ocean) ..... 13  
     C. Groundwater Limitations – Not Applicable ..... 16  
 VI. Provisions ..... 16  
     A. Standard Provisions..... 16  
     B. Monitoring and Reporting Program (MRP) Requirements ..... 16  
     C. Special Provisions..... 16  
         1. Reopener Provisions..... 16  
         2. Special Studies, Technical Reports and Additional Monitoring Requirements..... 16  
         3. Best Management Practices and Pollution Prevention ..... 18  
         4. Construction, Operation and Maintenance Specifications – Not Applicable..... 19  
         5. Special Provisions for Municipal Facilities (POTWs Only) – Not Applicable ..... 19  
         6. Other Special Provisions..... 19  
         7. Compliance Schedules – Not Applicable ..... 20  
 VII. Compliance Determination ..... 20

**List of Tables**

Table 1. Discharger Information ..... 1  
 Table 2. Discharge Location ..... 1  
 Table 3. Administrative Information ..... 1  
 Table 4. Facility Information..... 4  
 Table 5. Basin Plan Beneficial Uses..... 6  
 Table 6. Ocean Plan Beneficial Uses ..... 7  
 Table 7. Effluent Limitations Based on Table A of the Ocean Plan ..... 9  
 Table 8a. Effluent Limitations, Protection of Marine Aquatic Life, Discharge Point No. 001 .... 10  
 Table 8b. Effluent Limitations, Protection of Human Health – Non-Carcinogens, Discharge  
     Point No. 001..... 11  
 Table 8c. Effluent Limitations, Protection of Human Health – Carcinogens, Discharge Point No.  
     001 ..... 11  
 Table 9. Toxicity Reduction Evaluation—Schedule ..... 17

**List of Attachments**

Attachment A – Definitions ..... A-1  
Attachment B – Map ..... B-1  
Attachment C – Flow Schematic..... C-1  
Attachment D – Standard Provisions..... D-1  
Attachment E – Monitoring and Reporting Program (MRP) ..... E-1  
Attachment F – Fact Sheet..... F-1

**I. Facility Information**

The following Discharger is subject to waste discharge requirements as set forth in this Order.

**Table 4. Facility Information**

<b>Discharger</b>	Chevron Environmental Management Company
<b>Name of Facility</b>	Chevron Estero Marine Terminal
<b>Facility Address</b>	4000 Highway One
	Morro Bay, CA 93442
	San Luis Obispo County
<b>Facility Contact, Title, Phone</b>	Andy Smith, Project Manager, (805) 546-6915
<b>Mailing Address</b>	4000 Highway One, Morro Bay, CA 93442
<b>Type of Facility</b>	Former Oil Tanker Loading Terminal
<b>Facility Design Flow</b>	0.21 million gallons per day (MGD)

**II. Findings**

The California Water Regional Water Quality Control Board, Central Coast Region (hereinafter the Central Coast Water Board) finds:

**A. Background.** The Chevron Environmental Management Company (hereinafter Discharger) is currently discharging pursuant to Order No. R3-2011-0219 and National Pollutant Discharge Elimination System (NPDES) Permit No. CA0001465. The Discharger submitted a Report of Waste Discharge, dated July 29, 2016, and applied for an NPDES permit renewal to discharge up to 0.21 MGD of treated wastewater from the Chevron Estero Marine Terminal (hereinafter Facility). The application was deemed complete on January 13, 2016.

For the purposes of this Order, references to the “Discharger,” “Facility,” or “Permittee” in applicable federal and state laws, regulations, plans, or policy are held to be equivalent to references to the Discharger herein.

**B. Facility Description.**

The Discharger owns and operates Chevron Estero Marine Terminal, a former oil tanker loading terminal and fuel storage facility. The Discharger is currently decommissioning the facility and proposes to utilize a temporary wastewater treatment system used to treat up to a monthly average of 0.21 MGD of wastewater generated during the planned decommissioning and remediation projects on the site and the decommissioning of the out-of-service submarine loading lines and off-site pipelines. The temporary treatment system will consist of a minimum of two 21,000-gallon capacity portable storage tanks, a 55-gallon vapor-phase granular activated carbon (GAC) canister, an oil/water separator where separate petroleum will be decanted and transferred to a 500-gallon poly tank, two bag filters in parallel to remove sediment, one 1,000-pound clay media filter and two 2,000-pound liquid GAC canisters connected in series, and a 21,000-gallon treated water storage tank. The design average daily flow rate is 0.21 MGD.

Wastewater is discharged from Discharge Point No. 001 through a 3,000-foot long pipeline to the Pacific Ocean, a water of the United States within the Estero Bay Hydrologic Unit, with a minimum initial dilution ratio of 15:1 (seawater: effluent). Storm water is discharged from several discharge points on the site but is not regulated under this Order.

Attachment B provides a map of the area around the Facility. Attachment C provides a Facility flow schematic.

- C. Legal Authorities.** This Order is issued pursuant to Clean Water Act (CWA) §402 and implementing regulations adopted by the USEPA and chapter 5.5, division 7 of the California Water Code (CWC), commencing with §13370. It shall serve as an NPDES permit for point source discharges from this facility to surface waters. This Order also serves as Waste Discharge Requirements (WDRs) pursuant to article 4, chapter 4, division 7 of the CWC, commencing with §13260.
- D. Background and Rationale for Requirements.** The Central Coast Water Board developed the requirements in this Order based on information submitted as part of the application, through monitoring and reporting programs, and other available information. The Fact Sheet (Attachment F), which contains background information and rationale for Order requirements, is hereby incorporated into this Order and constitutes part of the Findings for this Order. Attachments A through E are also incorporated into this Order.
- E. California Environmental Quality Act (CEQA).** Pursuant to CWC §13389, this action to adopt an NPDES permit is exempt from the provisions of the CEQA, Public Resources Code sections 21100-21177.
- F. Technology-Based Effluent Limitations.** CWA §301(b) and EPA's NPDES regulations at 40 CFR 122.44 require that permits include, at a minimum, conditions meeting applicable technology-based requirements and any more stringent effluent limitations necessary to meet applicable water quality standards. Discharges authorized by this Order must meet minimum federal technology-based requirements based on Best Professional Judgment (BPJ) in accordance with 40 CFR 125.3. A detailed discussion of development of technology-based effluent limitations is included in the Fact Sheet (Attachment F).
- G. Water Quality-Based Effluent Limitations.** CWA §301(b) and NPDES regulations at 40 CFR 122.44(d) require that permits include limitations more stringent than applicable federal technology-based requirements where necessary to achieve applicable water quality standards.

NPDES regulations at 40 CFR 122.44(d)(1)(i) mandate that permits include effluent limitations for all pollutants that are or may be discharged at levels that have the reasonable potential to cause or contribute to an exceedance of a water quality standard, including numeric and narrative objectives within a standard. Where reasonable potential is established for a pollutant, but there is no numeric criterion or objective for the pollutant, water quality-based effluent limitations (WQBELs) must be established using: (1) USEPA

criteria guidance under CWA §304(a), supplemented where necessary by other relevant information; (2) an indicator parameter for the pollutant of concern; or (3) a calculated numeric water quality criterion, such as a proposed state criterion or policy interpreting the state’s narrative criterion, supplemented with other relevant information, as provided at 40 CFR 122.44(d)(1)(vi).

**H. Water Quality Control Plans.** The Central Coast Water Board has adopted the *Water Quality Control Plan for the Central Coastal Region* (the Basin Plan), which designates beneficial uses, establishes water quality objectives (WQOs), and contains implementation programs and policies to achieve those objectives for receiving waters within the Region. To address ocean waters, the Basin Plan incorporates by reference the *Water Quality Control Plan for Ocean Waters of California* (the Ocean Plan). The Ocean Plan is discussed in further detail in section II.I of this Order.

The Basin Plan implements State Water Resources Control Board (State Water Board) Resolution No. 88-63, which establishes State policy that all waters, with certain exceptions, should be considered suitable or potentially suitable for municipal or domestic supply (MUN). Because total dissolved solids (TDS) levels for marine waters exceed 3,000 mg/L, such waters are not considered suitable for municipal or domestic supply and therefore meet an exception to Resolution No. 88-63. Beneficial uses established by the Basin Plan for the Pacific Ocean at Estero Bay are presented below.

**Table 5. Basin Plan Beneficial Uses**

Discharge Point	Receiving Water	Beneficial Use(s)
001	Pacific Ocean at Estero Bay	Water Contact Recreation (REC-1) Non-contact Water Recreation (REC-2) Industrial Service Supply (IND) Navigation (NAV) Marine Habitat (MAR) Shellfish Harvesting (SHELL) Commercial and Sport Fishing (COMM) Rare, threatened, or endangered species (RARE) Wildlife Habitat (WILD)

Requirements of this Order implement the Basin Plan.

**I. California Ocean Plan.** The State Water Board adopted the Water Quality Control Plan for Ocean Waters of California, California Ocean Plan (Ocean Plan) in 1972 and amended it in 1978, 1983, 1988, 1990, 1997, 2000, 2005, and 2009. The State Water Board adopted the latest amendment on September 15, 2009, which was approved by the Office of Administrative Law on March 10, 2020, and subsequently the USEPA. The Ocean Plan is applicable, in its entirety, to point source discharges to the Pacific Ocean. The Ocean Plan identifies beneficial uses of ocean waters of the State to be protected as summarized in Table 6, below.

**Table 6. Ocean Plan Beneficial Uses**

Discharge Point	Receiving Water	Beneficial Use(s)
001	Pacific Ocean at Estero Bay	Industrial water supply Water contact recreation Non-contact recreation Navigation Commercial and sport fishing Mariculture Preservation and enhancement of designated Areas of Special Biological Significance (ASBS) Rare and endangered species Marine habitat Fish migration Fish spawning and shellfish harvesting

In Order to protect the beneficial uses, the Ocean Plan establishes WQOs and a program of implementation. Requirements of this Order implement the Ocean Plan.

**J. Alaska Rule.** On March 30, 2000, USEPA revised its regulation that specifies when new and revised state and tribal water quality standards become effective for CWA purposes. [65 Fed. Reg. 24641 (April 27, 2000), codified at 40 CFR 131.21] Under the revised regulation (also known as the Alaska Rule), new and revised standards submitted to USEPA after May 30, 2000 must be approved by USEPA before being used for CWA purposes. The final rule also provides that standards already in effect and submitted to USEPA by May 30, 2000, may be used for CWA purposes, whether or not approved by USEPA.

**K. Stringency of Requirements for Individual Pollutants.** This Order contains both technology-based and WQBELs for individual pollutants. As discussed in section IV. B of the Fact Sheet, the Order establishes technology-based effluent limitations for oil and grease, total suspended solids, settleable solids, pH, and turbidity for Discharge Point No. 001. These technology-based limitations implement the minimum, applicable federal technology-based requirements. These limitations are not more stringent than required by the CWA.

WQBELs have been scientifically derived to implement WQOs that protect beneficial uses. The WQOs and beneficial uses implemented by this Order are contained in the Basin Plan and the 2009 Ocean Plan. These WQOs and beneficial uses are the applicable water quality standards pursuant to 40 CFR 131.21(c)(1) and have been approved pursuant to federal law. WQBELs for toxic pollutants are derived using procedures established by the Ocean Plan.

All beneficial uses and WQOs contained in the Basin Plan were approved under state law and submitted to and approved by USEPA prior to May 30, 2000. Any WQOs and beneficial uses submitted to USEPA prior to May 30, 2000, but not approved by USEPA before that date, are nonetheless “applicable water quality standards for purposes of the CWA” pursuant to section 131.21(c)(1). Collectively, this Order’s restrictions on individual pollutants are no more stringent than required to implement the requirements of the CWA.

- L. Antidegradation Policy.** NPDES regulations at 40 CFR 131.12 require that State water quality standards include an antidegradation policy consistent with the federal policy. The State Water Board established California's antidegradation policy in State Water Board Resolution No. 68-16, which incorporates the federal antidegradation policy where the federal policy applies under federal law. Resolution No. 68-16 requires that the existing quality of waters be maintained unless degradation is justified based on specific findings. The Basin Plan implements and incorporates by reference both the State and federal antidegradation policies. As discussed in section IV.D.2 of the Fact Sheet, the permitted discharge is consistent with the antidegradation provisions of 40 CFR 131.12 and State Water Board Resolution No. 68-16.
- M. Anti-Backsliding Requirements.** CWA §402(o)(2) and §303(d)(4) and NPDES regulations at 40 CFR 122.44 (l) prohibit backsliding in NPDES permits. These anti-backsliding provisions require effluent limitations in a reissued permit to be as stringent as those in the previous permit, with some exceptions where limitations may be relaxed. As discussed in section IV.D.1 of the Fact Sheet, effluent limitations and other requirements established by this Order satisfy applicable anti-backsliding provisions of the CWA and NPDES regulations.
- N. Endangered Species Act.** This Order does not authorize any act that results in the taking of a threatened or endangered species or any act that is now prohibited, or becomes prohibited in the future, under either the California Endangered Species Act (Fish and Game Code §2050 to §2097) or the federal Endangered Species Act (16 U.S.C.A. §1531 to §1544). This Order requires compliance with effluent limits, receiving water limits, and other requirements to protect the beneficial uses of waters of the State. The Discharger is responsible for meeting all requirements of State and federal law regarding threatened and endangered species.
- O. Monitoring and Reporting.** NPDES regulations at 40 CFR 122.48 require that all NPDES permits specify requirements for recording and reporting monitoring results. CWC §13267 and §13383 authorize the Central Coast Water Board to require technical and monitoring reports. The Monitoring and Reporting Program (Attachment E) establishes monitoring and reporting requirements to implement federal and State requirements.
- P. Standard and Special Provisions.** Standard Provisions, which apply to all NPDES permits in accordance with NPDES regulations at 40 CFR 122.41, and additional conditions applicable to specified categories of permits in accordance with 40 CFR 122.42, are provided in Attachment D. The Central Coast Water Board has also included in this Order special provisions applicable to the Discharger. A rationale for the special provisions contained in this Order is provided in the attached Fact Sheet
- Q. Provisions and Requirements Implementing State Law.** The provisions/requirements in subsections IV.B, IV.C, and V.C of this Order are included to implement state law only. These provisions/requirements are not required or authorized under the federal CWA; consequently, violations of these provisions/requirements are not subject to the enforcement remedies that are available for NPDES violations.



- R. Notification of Interested Parties.** The Central Coast Water Board has notified the Discharger and interested agencies and persons of its intent to prescribe Waste Discharge Requirements for the discharge and has provided them with an opportunity to submit their written comments and recommendations. Details of notification are provided in the Fact Sheet accompanying this Order.
- S. Consideration of Public Comment.** The Central Coast Water Board, in a public meeting, heard and considered all comments pertaining to the discharge. Details of the Public Hearing are provided in the Fact Sheet of this Order.
- T. Privilege to Discharge.** A permit and the privilege to discharge waste into waters of the State is conditional upon the discharge complying with provisions of Division 7 of the CWC and the CWA (as amended or supplemented by implementing guidelines and regulations); and with any more stringent effluent limitations necessary to implement water quality control plans, to protect beneficial uses, and to prevent nuisances.

**III. Discharge Prohibitions**

- A.** Discharge of treated wastewater at a location or in a manner other than as described by this Order is prohibited (excluding storm water regulated by General Permit No. CAS000001).
- B.** The bypass or overflow of wastewater or wastes to surface waters or surface water drainage courses, except as provided for in Attachment D, Standard Provision I.G (Bypass), is prohibited.
- C.** The discharge of any waste not specifically regulated by this Order is prohibited.

**IV. Effluent Limitations and Discharge Specifications**

**A. Effluent Limitations – Discharge Point No. 001**

**1. Effluent Limitations – Discharge Point No. 001**

- a.** The Discharger shall maintain compliance with the following effluent limitations at Discharge Point No. 001, with compliance measured at Monitoring Location M-001 as described in the attached MRP.

**Table 7. Effluent Limitations Based on Table A of the Ocean Plan**

Parameter	Units	Effluent Limitations		
		Average Monthly	Average Weekly	Maximum Daily
Oil and Grease	mg/L	25	40	75
TSS	mg/L	[1]		
Settleable Solids	ml/L	1.0	1.5	3.0
pH	s.u.	6.0 – 9.0 <sup>[2]</sup>		
Turbidity	NTU	75	100	225

[1] The Discharger shall, as a 30-day average, remove 75% of suspended solids from the influent stream before discharging wastewaters to the ocean, except that the effluent limitation to be met shall not be lower than 60 mg/L.

Parameter	Units	Effluent Limitations		
		Average Monthly	Average Weekly	Maximum Daily

<sup>[2]</sup> The effluent shall be between 6.0 and 9.0 standard units at all times.

**b. Toxic Pollutants**

- i. The Discharger shall maintain compliance with the following effluent limitations for toxic pollutants at Discharge Point No. 001, with compliance measured at Monitoring Location M-001, as described in the attached MRP.

**Table 8a. Effluent Limitations, Protection of Marine Aquatic Life, Discharge Point No. 001**

Parameter	Units	6-Month Median <sup>[1]</sup>	Daily Maximum <sup>[2]</sup>	Instantaneous Maximum <sup>[3]</sup>
Arsenic, Total Recoverable	µg/L	80	470	1,200
Cadmium, Total Recoverable	µg/L	20	60	160
Chromium (VI), Total Recoverable <sup>[4]</sup>	µg/L	30	130	320
Copper, Total Recoverable	µg/L	20	160	450
Lead, Total Recoverable	µg/L	30	130	320
Mercury, Total Recoverable	µg/L	0.63	2.6	6.4
Nickel, Total Recoverable	µg/L	80	320	800
Selenium, Total Recoverable	µg/L	240	960	2,400
Silver, Total Recoverable	µg/L	10	40	110
Zinc, Total Recoverable	µg/L	200	1,200	3,100
Cyanide, Total Recoverable <sup>[5]</sup>	µg/L	20	60	160
Total Residual Chlorine <sup>[6]</sup>	µg/L	30	130	960
Ammonia (as N)	mg/L	9.6	38	96
Phenolic Compounds (non-chlorinated)	µg/L	480	1,900	4,800
Chronic Toxicity	TUc	--	16.0	--
Chlorinated Phenolics	µg/L	20	60	160
Endosulfan <sup>[7]</sup>	µg/L	0.14	0.29	0.43
Endrin	µg/L	0.03	0.06	0.10
HCH <sup>[8]</sup>	µg/L	0.06	0.13	0.19
Radioactivity		<sup>[9]</sup>		

<sup>[1]</sup> The six-month median shall apply as a moving median of daily values for any 180-day period in which daily values represent flow weighted average concentrations within a 24-hour period. For intermittent discharges, the daily value shall be considered equal to zero for days on which no discharge occurred. The six-month median limit on daily mass emissions shall be determined using the six-month median effluent concentration  $C_e$  and the observed flow rate,  $Q$ , in million gallons per day (MGD).

<sup>[2]</sup> The daily maximum shall apply to flow weighted 24-hour composite samples. The daily maximum mass emission shall be determined using the daily maximum effluent concentration limit as  $C_e$  and the observed flow rate,  $Q$ , in MGD.

<sup>[3]</sup> The instantaneous maximum shall apply to grab sample determinations.

<sup>[4]</sup> The Discharger may, at their option, meet this limitation as a total chromium limitation.

<sup>[5]</sup> If a Discharger can demonstrate to the satisfaction of the Central Coast Water Board (subject to USEPA approval) that an analytical method is available to reliably distinguish between strongly and weakly complexed cyanide, effluent limitations for cyanide may be met by the combined measurement of free cyanide, simple alkali metal cyanides, and weakly complexed organometallic cyanide complexes. In order for the analytical

Parameter	Units	6-Month Median <sup>[1]</sup>	Daily Maximum <sup>[2]</sup>	Instantaneous Maximum <sup>[3]</sup>
-----------	-------	-------------------------------	------------------------------	--------------------------------------

method to be acceptable, the recovery of free cyanide from metal complexes must be comparable to that achieved by the approved method in 40 CFR 136.

[6] Water quality objectives for total chlorine residual applying to intermittent discharges not exceeding two hours shall be determined using the following equation:

$$\log(y) = -0.43 (\log x) + 1.8$$

where: y = the water quality objective (in µg/L) to apply when chlorine is being discharged  
 x = the duration of uninterrupted chlorine discharges in minutes

The applicable effluent limitation must then be determined using Equation No. 1 from the Ocean Plan.

[7] Shall mean the sum of endosulfan-alpha and -beta and endosulfan sulfate.

[8] Shall mean the sum of the alpha, beta, gamma and delta isomers of hexachlorocyclohexane.

[9] Radioactivity is not to exceed limits specified in Title 17, Division 1, Chapter 5, Subchapter 4, Group 3, Article 3, Section 30253 of the California Code of Regulations. Reference to Section 30253 is prospective including future changes to incorporate provisions of federal law, as the changes take effect.

**Table 8b. Effluent Limitations, Protection of Human Health – Non-Carcinogens, Discharge Point No. 001**

Parameter	Units	30-Day Average
Acrolein	µg/L	3,500
Antimony	µg/L	19,000
Bis(2-Chloroethoxy)Methane	µg/L	70
Bis(2-Chloroisopropyl)Ether	µg/L	19,000
Chlorobenzene	µg/L	9,100
Chromium (III)	µg/L	3,000,000
Di-n-butyl Phthalate	µg/L	56,000
Dichlorobenzenes	µg/L	82,000
Diethyl Phthalate	µg/L	530,000,000
Dimethyl Phthalate	µg/L	13,000,000
4,6-Dinitro-2-Methylphenol	µg/L	3,500
2,4-Dinitrophenol	µg/L	60
Ethylbenzene	µg/L	65,000
Fluoranthene	µg/L	240
Hexachlorocyclopentadiene	µg/L	930,000
Nitrobenzene	µg/L	80
Thallium	µg/L	220,000
Toluene	µg/L	1,400
Tributyltin	µg/L	20,000
1,1,1-Trichloroethane	µg/L	8,600

**Table 8c. Effluent Limitations, Protection of Human Health – Carcinogens, Discharge Point No. 001**

Parameter	Units	30-Day Average
Acrylonitrile	µg/L	1.6
Aldrin	µg/L	0.00035

Parameter	Units	30-Day Average
Benzene	µg/L	94
Benzidine	µg/L	0.001
Beryllium	µg/L	0.53
Bis(2-Chloroethyl)Ether	µg/L	0.72
Bis(2-Ethylhexyl)Phthalate	µg/L	56
Carbon Tetrachloride	µg/L	14
Chlordane <sup>[1]</sup>	ng/L	0.00037
Chloroform	µg/L	2,100
DDT <sup>[2]</sup>	µg/L	0.0027
1,4-Dichlorobenzene	µg/L	290
3,3'-Dichlorobenzidine	µg/L	0.13
1,2-Dichloroethane	µg/L	2,100
1,1-Dichloroethylene	µg/L	110,000
Dichloromethane	µg/L	7,200
1,3-Dichloropropene	µg/L	140
Dieldrin	µg/L	0.00064
2,4-Dinitrotoluene	µg/L	42
1,2-Diphenylhydrazine	µg/L	2.6
Halomethanes <sup>[3]</sup>	µg/L	2,100
Heptachlor <sup>[4]</sup>	µg/L	0.01
Hexachlorobenzene	µg/L	0.0034
Hexachlorobutadiene	µg/L	220
Hexachloroethane	µg/L	40
Isophorone	µg/L	2,400
N-Nitrosodimethylamine	µg/L	120
N-Nitrosodiphenylamine	µg/L	40
PAHs <sup>[5]</sup>	µg/L	0.14
PCBs <sup>[6]</sup>	µg/L	0.0003
TCDD Equivalents <sup>[7]</sup>	µg/L	6.0E-08
1,1,2,2-Tetrachloroethane	µg/L	19,000
Tetrachloroethylene	µg/L	1,600
Toxaphene	µg/L	0.0034
Trichloroethylene	µg/L	430
2,4,6-Trichlorophenol	µg/L	4.6
Vinyl Chloride	µg/L	580.0
1,1,2-Trichloroethane	µg/L	690,000

Parameter	Units	30-Day Average
-----------	-------	----------------

- [1] Chlordane shall mean the sum of chlordane-alpha, chlordane-gamma, chlordene-alpha, chlordene-gamma, nonachlor-alpha, nonachlor-gamma, and oxychlordane.
- [2] DDT shall mean the sum of 4,4'-DDT; 2,4'-DDT; 4,4'-DDE; 4,4'-DDD; and 2,4'-DDD.
- [3] Halomethanes shall mean the sum of bromoform, bromomethane (methyl bromide), chloromethane (methyl chloride), chlorodibromomethane, and dichlorobromomethane.
- [4] Heptachlor shall mean the sum of heptachlor and heptachlor epoxide.
- [5] PAHS (Polynuclear aromatic hydrocarbons) shall mean the sum of acenaphthylene; anthracene; 1,2-benzanthracene; 3,4-benzofluoranthene; benzo(k)fluoranthene; 1,12-benzoperylene; benzo(a)pyrene; chrysene; dibenzo(a,h)anthracene; fluorene; indeno(1,2,3-cd)pyrene; phenanthrene; and pyrene.
- [6] PCBs (polychlorinated biphenyls) shall mean the sum of chlorinated biphenyls whose analytical characteristics resemble those of Aroclor-1016, Aroclor-1221, Aroclor-1232, Aroclor-1242, Aroclor-1248, Aroclor-1254, and Aroclor-1260.
- [7] TCDD Equivalents shall mean the sum of those concentrations of chlorinated dibenzodioxins (2,3,7,8-CDDs) and chlorinated dibenzofurans (2,3,7,8-CDFs) multiplied by their respective toxicity factors, as listed in Appendix I of the Ocean Plan.

**2. Dry Weather Flow:** Effluent daily dry weather flow shall not exceed a monthly average of 0.21 MGD.

**3.** Effluent shall be essentially free of materials and substances that:

- a. Float or become floatable upon discharge;
- b. May form sediments that degrade benthic communities or aquatic biota;
- c. Accumulate to toxic levels in marine waters, sediments, or biota;
- d. Decrease the natural light to benthic communities and other marine life; and
- e. Result in aesthetically undesirable discoloration of the ocean surface.

**B. Interim Effluent Limitations – Not Applicable**

**C. Land Discharge Effluent Limitations and Specifications – Not Applicable**

**D. Recycling Specifications – Not Applicable**

**V. Receiving Water Limitations**

**A. Surface Water Limitations for Discharge Point No. 001 (Pacific Ocean)**

Receiving water limitations are based on WQOs contained in the Ocean Plan and Basin Plan and are a required part of this Order. These receiving water limitations are

designed to minimize the influence of discharge to the receiving water. The discharge shall comply with the following receiving water limitations.

## 1. Bacterial Characteristics

- a. Within a zone bounded by the shoreline and a distance of three nautical miles from the shoreline, including all kelp beds, the following bacterial objectives shall be maintained throughout the water column. The zone of initial dilution for ocean outfall is excluded.

30-day Geometric Mean – The following standards are based on the geometric mean of the five most recent samples from each site:

- i. Total coliform density shall not exceed 1,000 per 100 ml;
- ii. Fecal coliform density shall not exceed 200 per 100 ml; and
- iii. Enterococcus density shall not exceed 35 per 100 ml.

Single Sample Maximum:

- iv. Total coliform density shall not exceed 10,000 per 100 ml;
- v. Fecal coliform density shall not exceed 400 per 100 ml;
- vi. Enterococcus density shall not exceed 104 per 100 ml; and
- vii. Total coliform density shall not exceed 1,000 per 100 ml when the fecal coliform/total coliform ratio exceeds 0.1.

## 2. Physical Characteristics

- a. Floating particulates and grease and oil shall not be visible on the ocean surface.
- b. The discharge of waste shall not cause aesthetically undesirable discoloration of the ocean surface.
- c. Natural light shall not be significantly reduced at any point outside the zone of initial dilution as the result of the discharge of waste.
- d. The rate of deposition of inert solids and the characteristics of inert solids in ocean sediments shall not be changed such that benthic communities are degraded.
- e. Temperature of the receiving water shall not be altered to adversely affect beneficial uses, as set forth in the Water Quality Control Plan for Control of Temperature in the Coastal and Interstate Waters and Enclosed Bays and Estuaries of California.

### **3. Chemical Characteristics**

- a. The dissolved oxygen concentration shall not, at any time, be depressed more than 10 percent from that which occurs naturally or fall below 5.0 mg/L as the result of the discharge of oxygen demanding waste materials. The mean annual dissolved oxygen concentration shall not be less than 7.0 mg/L.
- b. The pH shall not be changed at any time more than 0.2 units from that which occurs naturally, and shall be within the range of 7.0 to 8.5 at all times.
- c. The dissolved sulfide concentrations of waters in and near sediments shall not be significantly increased above that present under natural conditions.
- d. The concentrations of substances set forth in Table B of the Ocean Plan shall not be increased in marine sediments to that which would degrade indigenous biota.
- e. The concentration of organic materials in marine sediments shall not be increased to that which would degrade marine life.
- f. Nutrient materials shall not cause objectionable aquatic growth or degrade indigenous biota.

### **4. Biological Characteristics**

- a. Marine communities, including vertebrate and plant species, shall not be degraded.
- b. The natural taste, odor, and color of fish, shellfish, or other marine resources used for human consumption shall not be altered.
- c. The concentration of organic materials in fish, shellfish, or other marine resources used for human consumption shall not bioaccumulate to levels that are harmful to human health.

### **5. Radioactivity**

- a. Discharge of radioactive waste shall not degrade marine life.
- b. Radionuclides shall not be present in concentrations that are deleterious to human, plant, animal, or aquatic life; or result in the accumulation of radionuclides in the food web to an extent that presents a hazard to human, plant, animal, or aquatic life.

### **6. General Standards**

- a. The discharge shall not cause a violation of any applicable WQO or standard for receiving waters adopted by the Central Coast Water Board or State Water Board, as required by the CWA and regulations adopted thereunder.

- b. Waste management systems that discharge to the ocean must be designed and operated in a manner that will maintain the indigenous marine life and a healthy and diverse marine community.
- c. Waste effluents shall be discharged in a manner that provides sufficient initial dilution to minimize the concentrations of substances not removed in the treatment.

### **C. Groundwater Limitations – Not Applicable**

## **VI. Provisions**

### **A. Standard Provisions**

- 1. **Federal Standard Provisions.** The Discharger shall comply with all Standard Provisions included in Attachment D of this Order.
- 2. **Central Coast Water Board Standard Provisions.** The Discharger shall comply with all Central Coast Water Board Standard Provisions included in Attachment D-1 of this Order.

### **B. Monitoring and Reporting Program (MRP) Requirements**

The Discharger shall comply with the MRP, and future revisions thereto, in Attachment E of this Order. All monitoring shall be conducted according to 40 CFR Part 136, *Guidelines Establishing Test Procedures for Analysis of Pollutants*.

### **C. Special Provisions**

#### **1. Reopener Provisions**

- 1. This permit may be reopened and modified in accordance with NPDES regulations at 40 CFR 122 and 124, as necessary, to include additional conditions or limitations based on newly available information or to implement any USEPA approved, new, State WQO.
- 2. This Order may be reopened for modification to include an effluent limitation if monitoring establishes that the discharge causes, has the reasonable potential to cause, or contributes to an excursion above a California Ocean Plan (Ocean Plan) Table 1 water quality objective.

#### **2. Special Studies, Technical Reports and Additional Monitoring Requirements**

##### **a. Toxicity Reduction Requirements**

If monitoring measures chronic toxicity in the effluent above 16 TUc, the Discharger shall increase the frequency of chronic toxicity monitoring to once per week and submit the results within 15 days of the conclusion of each test to the Central Coast Water Board. The Executive Officer will determine whether to initiate enforcement action, whether to require the Discharger to implement a



Toxicity Reduction Evaluation (TRE), or to implement other measures. If directed by the Executive Officer, the Discharger shall conduct a TRE giving due consideration to guidance provided by the USEPA's TRE Procedures, Phases 1, 2, and 3, or later revised editions:

- i. *Generalized Methodology for Conducting Industrial Toxicity Reduction Evaluations (EPA/600/2-88/070).*
- ii. *Methods for Aquatic Toxicity Identification Evaluations: Phase I Toxicity Characterization, Second Edition (EPA/600/R-91/003).*
- iii. *Methods for Aquatic Toxicity Identification Evaluations, Phase II Toxicity Identification Procedures for Samples Exhibiting Acute and Chronic Toxicity (EPA/600/R-92/080).*
- iv. *Methods for Aquatic Toxicity Identification Evaluations, Phase III Toxicity Confirmation Procedures for Samples Exhibiting Acute and Chronic Toxicity (EPA/600/R-92/081).*

Once sources of toxicity are identified, the Discharger shall take reasonable steps necessary to reduce toxicity to the required level. At a minimum, the TRE Workplan shall include:

- i. Actions that will be taken to investigate/identify the causes/sources of toxicity,
- ii. Actions that will be evaluated to mitigate the impact of the discharge, to correct the non-compliance, and/or to prevent the recurrence of acute or chronic toxicity (this list of action steps may be expanded, if a TRE is undertaken), and
- iii. A schedule under which these actions will be implemented.

A TRE, if necessary, shall be conducted in accordance with the following schedule.

**Table 9. Toxicity Reduction Evaluation—Schedule**

Action Step	When Required
Take all reasonable measures necessary to immediately reduce toxicity, where the source is known.	Within 24 hours of identification of noncompliance.
Submit to the Executive Officer a TRE study plan describing the toxicity reduction procedures to be employed.	Within 60 days of identification of non-compliance.
Initiate the TRE in accordance to the workplan.	To be determined by Executive Officer
Conduct the TRE following the procedures in the workplan.	Within the period specified in the Workplan (not to exceed one year, without an approved Workplan), or as otherwise specified by the Executive Officer

Action Step	When Required
Submit the results of the TRE, including summary of findings, required corrective action, and all results and data.	Within 60 days of completion of the TRE
Implement corrective actions to meet Order limitations and conditions.	To be determined by the Executive Officer
Return to regular monitoring	One-year period or as specified by workplan

**3. Best Management Practices and Pollution Prevention**

**a. Pollutant Minimization Program (PMP)**

The goal of the PMP is to reduce potential sources of Ocean Plan Table B toxic pollutants through pollutant minimization (control) strategies, including pollution prevention measures, to maintain effluent concentrations at or below the effluent limitation.

**i. Determining the Need for a PMP**

**(a)** The Discharger shall develop and implement a PMP if:

- (1)** A calculated effluent limitation is less than the reported Minimum Level (ML);
- (2)** The concentration of the pollutant is reported as DNQ; and,
- (3)** There is evidence showing that the pollutant is present in the effluent above the calculated effluent limitation. Such evidence may include: health advisories for fish consumption; presence of whole effluent toxicity; results of benthic or aquatic organism tissue sampling; sample results from analytical methods more sensitive than methods included in the permit; and the concentration of the pollutant is reported as DNQ and the effluent limitation is less than the MDL.

**(b)** Alternatively, the Discharger shall develop and implement a PMP if:

- (1)** A calculated effluent limitation is less than the Method Detection Limit (MDL);
- (2)** The concentration of the pollutant is reported as ND; and,
- (3)** There is evidence showing that the pollutant is present in the effluent above the calculated effluent limitation. Such evidence may include: health advisories for fish consumption; presence of whole effluent toxicity; results of benthic or aquatic organism tissue sampling; sample results from analytical methods more sensitive than methods included

in the permit; and the concentration of the pollutant is reported as DNQ and the effluent limitation is less than the MDL.

**ii. Elements of a PMP**

A PMP shall include actions and submittals acceptable to the Central Coast Water Board including, but not limited to, the following.

- (a) An annual review and semiannual monitoring of potential sources of the reportable pollutant, which may include fish tissue monitoring and other bio-uptake sampling;
- (b) Quarterly monitoring for the reportable pollutant in influent to the wastewater treatment system;
- (c) Submittal of a control strategy designed to proceed toward the goal of maintaining concentrations of the reportable priority pollutant in the effluent at or below the calculated effluent limitation;
- (d) Implementation of appropriate cost-effective control measures for the pollutant, consistent with the control strategy;
- (e) An annual status report that shall be sent to the Executive Officer that includes:
  - (1) All PMP monitoring results for the previous year;
  - (2) A list of potential sources of the reportable pollutant;
  - (3) A summary of all actions taken in accordance with the control strategy; and,
  - (4) A description of actions to be taken in the following year.

**4. Construction, Operation and Maintenance Specifications – Not Applicable**

**5. Special Provisions for Municipal Facilities (POTWs Only) – Not Applicable**

**6. Other Special Provisions**

- a. **Discharges of Storm Water.** For the control of storm water discharged from the Facility, the Discharger shall seek authorization to discharge under and meet the requirements of the State Water Board's Water Quality Order 2014-0057-DWQ, NPDES General Permit No. CAS000001, General Permit For Storm Water Discharges Associated with Industrial Activities.
- b. **Operation of GAC Canisters.** The granular activated carbon (GAC) system shall be operated and monitored in accordance with the MRP, Attachment E.

- c. **Rescission of Order.** After Chevron Estero Marine Terminal facility decommissioning is complete and discharges associated with these cleanup efforts are terminated, this Order may be reopened by the Central Coast Water Board.
- d. **Reevaluation of Effluent Limitations.** If there is a significant change in waste flow at the Facility, the Central Coast Water Board may reevaluate the current effluent limitations and reopen the Order if deemed appropriate.

## 7. Compliance Schedules – Not Applicable

## VII. Compliance Determination

Compliance with the effluent limitations contained in section IV of this Order will be determined as specified below:

- A. **General.** Compliance with effluent limitations for reportable pollutants shall be determined using sample reporting protocols defined in the MRP and Attachment A of this Order. For purposes of reporting and administrative enforcement by the Central Coast and State Water Boards, the Discharger shall be deemed out of compliance with effluent limitations if the concentration of the reportable pollutant in the monitoring sample is greater than the effluent limitation and greater than or equal to the reported Minimum Level (ML).
- B. **Multiple Sample Data.** When determining compliance with a measure of central tendency (arithmetic mean, geometric mean, median, etc.) of multiple sample analyses and the data set contains one or more reported determinations of “Detected, but Not Quantified” (DNQ) or “Not Detected” (ND), the Discharger shall compute the median in place of the arithmetic mean in accordance with the following procedure:
  - 7. The data set shall be ranked from low to high, ranking the reported ND determinations lowest, DNQ determinations next, followed by quantified values (if any). The order of the individual ND or DNQ determinations is unimportant.
  - 8. The median value of the data set shall be determined. If the data set has an odd number of data points, then the median is the middle value. If the data set has an even number of data points, then the median is the average of the two values around the middle unless one or both of the points are ND or DNQ, in which case the median value shall be the lower of the two data points where DNQ is lower than a value and ND is lower than DNQ.

## Attachment A – Definitions

### Acute Toxicity:

- a. Acute Toxicity (TUa)

Expressed in Toxic Units Acute (TUa)

$$TUa = \frac{100}{\frac{96\text{-hr LC}}{50\%}}$$

- b. Lethal Concentration 50% (LC 50)

LC 50 (percent waste giving 50% survival of test organisms) shall be determined by static or continuous flow bioassay techniques using standard marine test species as specified in Ocean Plan Appendix III. If specific identifiable substances in wastewater can be demonstrated by the discharger as being rapidly rendered harmless upon discharge to the marine environment, but not as a result of dilution, the LC 50 may be determined after the test samples are adjusted to remove the influence of those substances.

When it is not possible to measure the 96-hour LC 50 due to greater than 50 percent survival of the test species in 100 percent waste, the toxicity concentration shall be calculated by the expression:

$$TUa = \frac{\log(100 - S)}{1.7}$$

where: S = percentage survival in 100% waste. If S > 99, TUa shall be reported as zero.

**Areas of Special Biological Significance (ASBS):** are those areas designated by the State Water Board as ocean areas requiring protection of species or biological communities to the extent that alteration of natural water quality is undesirable. All Areas of Special Biological Significance are also classified as a subset of STATE WATER QUALITY PROTECTION AREAS.

**Average Monthly Effluent Limitation (AMEL):** the highest allowable average of daily discharges over a calendar month, calculated as the sum of all daily discharges measured during a calendar month divided by the number of daily discharges measured during that month.

**Average Weekly Effluent Limitation (AWEL):** the highest allowable average of daily discharges over a calendar week (Sunday through Saturday), calculated as the sum of all daily discharges measured during a calendar week divided by the number of daily discharges measured during that week.

**Chlordane** shall mean the sum of chlordane-alpha, chlordane-gamma, chlordene-alpha, chlordene-gamma, nonachlor-alpha, nonachlor-gamma, and oxychlordane.

**Chronic Toxicity:** This parameter shall be used to measure the acceptability of waters for supporting a healthy marine biota until improved methods are developed to evaluate biological response.

a. Chronic Toxicity (TUc)

Expressed as Toxic Units Chronic (TUc)

$$TUc = \frac{100}{NOEL}$$

b. No Observed Effect Level (NOEL)

The NOEL is expressed as the maximum percent effluent or receiving water that causes no observable effect on a test organism, as determined by the result of a critical life stage toxicity test listed in Ocean Plan Appendix II.

**Daily Discharge:** Daily Discharge is defined as either: (1) the total mass of the constituent discharged over the calendar day (12:00 am through 11:59 pm) or any 24-hour period that reasonably represents a calendar day for purposes of sampling (as specified in the permit), for a constituent with limitations expressed in units of mass or; (2) the unweighted arithmetic mean measurement of the constituent over the day for a constituent with limitations expressed in other units of measurement (e.g., concentration).

The daily discharge may be determined by the analytical results of a composite sample taken over the course of one day (a calendar day or other 24-hour period defined as a day) or by the arithmetic mean of analytical results from one or more grab samples taken over the course of the day.

For composite sampling, if 1 day is defined as a 24-hour period other than a calendar day, the analytical result for the 24-hour period will be considered as the result for the calendar day in which the 24-hour period ends.

**DDT** shall mean the sum of 4,4'DDT, 2,4'DDT, 4,4'DDE, 2,4'DDE, 4,4'DDD, and 2,4'DDD.

**Degrade:** Degradation shall be determined by comparison of the waste field and reference site(s) for characteristic species diversity, population density, contamination, growth anomalies, debility, or supplanting of normal species by undesirable plant and animal species. Degradation occurs if there are significant differences in any of three major biotic groups, namely, demersal fish, benthic invertebrates, or attached algae. Other groups may be evaluated where benthic species are not affected, or are not the only ones affected.

**Detected, but Not Quantified (DNQ)** are those sample results less than the reported Minimum Level, but greater than or equal to the laboratory's MDL.

**Dichlorobenzenes** shall mean the sum of 1,2- and 1,3-dichlorobenzene.

**Downstream Ocean Waters** shall mean waters downstream with respect to ocean currents.

**Dredged Material:** Any material excavated or dredged from the navigable waters of the United States, including material otherwise referred to as “spoil”.

**Enclosed Bays** are indentations along the coast that enclose an area of oceanic water within distinct headlands or harbor works. Enclosed bays include all bays where the narrowest distance between headlands or outermost harbor works is less than 75 percent of the greatest dimension of the enclosed portion of the bay. This definition includes but is not limited to: Humboldt Bay, Bodega Harbor, Tomales Bay, Drakes Estero, San Francisco Bay, Morro Bay, Los Angeles Harbor, Upper and Lower Newport Bay, Mission Bay, and San Diego Bay.

**Endosulfan** shall mean the sum of endosulfan-alpha and -beta and endosulfan sulfate.

**Estuaries and Coastal Lagoons** are waters at the mouths of streams that serve as mixing zones for fresh and ocean waters during a major portion of the year. Mouths of streams that are temporarily separated from the ocean by sandbars shall be considered as estuaries. Estuarine waters will generally be considered to extend from a bay or the open ocean to the upstream limit of tidal action but may be considered to extend seaward if significant mixing of fresh and salt water occurs in the open coastal waters. The waters described by this definition include but are not limited to the Sacramento-San Joaquin Delta as defined by CWC §12220, Suisun Bay, Carquinez Strait downstream to Carquinez Bridge, and appropriate areas of the Smith, Klamath, Mad, Eel, Noyo, and Russian Rivers.

**Halomethanes** shall mean the sum of bromoform, bromomethane (methyl bromide) and chloromethane (methyl chloride).

**HCH** shall mean the sum of the alpha, beta, gamma (lindane) and delta isomers of hexachlorocyclohexane.

**Initial Dilution** is the process that results in the rapid and irreversible turbulent mixing of wastewater with ocean water around the point of discharge.

For a submerged buoyant discharge, characteristic of most municipal and industrial wastes that are released from the submarine outfalls, the momentum of the discharge and its initial buoyancy act together to produce turbulent mixing. Initial dilution in this case is completed when the diluting wastewater ceases to rise in the water column and first begins to spread horizontally.

For shallow water submerged discharges, surface discharges, and non-buoyant discharges, characteristic of cooling water wastes and some individual discharges, turbulent mixing results primarily from the momentum of discharge. Initial dilution, in these cases, is considered to be completed when the momentum induced velocity of the discharge ceases to produce significant mixing of the waste, or the diluting plume reaches a fixed distance from the discharge to be specified by the Central Coast Board, whichever results in the lower estimate for initial dilution.

**Instantaneous Maximum Effluent Limitation:** the highest allowable value for any single grab sample or aliquot (i.e., each grab sample or aliquot is independently compared to the instantaneous maximum limitation).

**Instantaneous Minimum Effluent Limitation:** the lowest allowable value for any single grab sample or aliquot (i.e., each grab sample or aliquot is independently compared to the instantaneous minimum limitation).

**Kelp Beds**, for purposes of the bacteriological standards of the Ocean Plan, are significant aggregations of marine algae of the genera Macrocystis and Nereocystis. Kelp beds include the total foliage canopy of Macrocystis and Nereocystis plants throughout the water column.

**Mariculture** is the culture of plants and animals in marine waters independent of any pollution source.

**Material:** (a) In common usage: (1) the substance or substances of which a thing is made or composed (2) substantial; (b) For purposes of the Ocean Plan relating to waste disposal, dredging and the disposal of dredged material and fill, MATERIAL means matter of any kind or description which is subject to regulation as waste, or any material dredged from the navigable waters of the United States. See also, DREDGED MATERIAL.

**Maximum Daily Effluent Limitation (MDEL):** the highest allowable daily discharge of a pollutant.

**MDL (Method Detection Limit)** The minimum concentration of a substance that can be measured and reported with 99 percent confidence that the analyte concentration is greater than zero, as defined in 40 C.F.R. part 136, Attachment B.

**Minimum Level (ML)** is the concentrations at which the entire analytical system must give a recognizable signal and acceptable calibration point. The ML is the concentration in a sample that is equivalent to the concentration of the lowest calibration standard analyzed by a specific analytical procedure, assuming that all the method-specified sample weights, volumes and processing steps have been followed.

**Natural Light:** Reduction of natural light may be determined by the Central Coast Water Board by measurement of light transmissivity or total irradiance, or both, according to the monitoring needs of the Central Coast Water Board.

**Not Detected (ND)** are those sample results less than the laboratory's MDL.

**Ocean Waters** are the territorial marine waters of the state as defined by California law to the extent these waters are outside of enclosed bays, estuaries, and coastal lagoons. If a discharge outside the territorial waters of the state could affect the quality of the waters of the state, the discharge may be regulated to assure no violation of the Ocean Plan will occur in ocean waters.

**PAHs (polynuclear aromatic hydrocarbons)** shall mean the sum of acenaphthylene, anthracene, 1,2-benzanthracene, 3,4-benzofluoranthene, benzo[k]fluoranthene, 1,12-benzoperylene, benzo[a]pyrene, chrysene, dibenzo[ah]anthracene, fluorene, indeno[1,2,3-cd]pyrene, phenanthrene and pyrene.



**PCBs (polychlorinated biphenyls)** shall mean the sum of chlorinated biphenyls whose analytical characteristics resemble those of Aroclor-1016, Aroclor-1221, Aroclor-1232, Aroclor-1242, Aroclor-1248, Aroclor-1254 and Aroclor-1260.

**Pollutant Minimization Program (PMP)** means waste minimization and pollution prevention actions that include, but are not limited to, product substitution, waste stream recycling, alternative waste management methods, and education of the public and businesses. The goal of the PMP shall be to reduce all potential sources of Ocean Plan Table B pollutants through pollutant minimization (control) strategies, including pollution prevention measures as appropriate, to maintain the effluent concentration at or below the water quality-based effluent limitation. Pollution prevention measures may be particularly appropriate for persistent bioaccumulative priority pollutants where there is evidence that beneficial uses are being impacted. The Central Coast Water Board may consider cost effectiveness when establishing the requirements of a PMP. The completion and implementation of a Pollution Prevention Plan, if required pursuant to CWC §13263.3(d), shall be considered to fulfill the PMP requirements.

**Reported Minimum Level** is the ML (and its associated analytical method) chosen by the Discharger for reporting and compliance determination from the MLs included in this Order. The MLs included in this Order correspond to approved analytical methods for reporting a sample result that are selected by the Central Coast Water Board either from Appendix II of the Ocean Plan in accordance with section III.C.5.a. of the Ocean Plan or established in accordance with section III.C.5.b. of the Ocean Plan. The ML is based on the proper application of method-based analytical procedures for sample preparation and the absence of any matrix interferences. Other factors may be applied to the ML depending on the specific sample preparation steps employed. For example, the treatment typically applied in cases where there are matrix-effects is to dilute the sample or sample aliquot by a factor of ten. In such cases, this additional factor must be applied to the ML in the computation of the reported ML.

**Satellite Collection System** is the portion, if any, of a sanitary sewer system owned or operated by a different public agency than the agency that owns and operates the wastewater treatment facility that a sanitary sewer system is tributary to.

**Shellfish** are organisms identified by the California Department of Health Services as shellfish for public health purposes (i.e., mussels, clams and oysters).

**Significant Difference** is defined as a statistically significant difference in the means of two distributions of sampling results at the 95 percent confidence level.

**Six-month Median Effluent Limitation:** the highest allowable moving median of all daily discharges for any 180-day period.

**State Water Quality Protection Areas (SWQPAs)** are non-terrestrial marine or estuarine areas designated to protect marine species or biological communities from an undesirable alteration in natural water quality. All AREAS OF SPECIAL BIOLOGICAL SIGNIFICANCE (ASBS) that were previously designated by the State Water Board in Resolution Nos. 74-28, 74-32, and 75-61 are now also classified as a subset of State Water Quality Protection Areas and require special protections afforded by the Ocean Plan.

**TCDD Equivalents** shall mean the sum of the concentrations of chlorinated dibenzodioxins (2,3,7,8-CDDs) and chlorinated dibenzofurans (2,3,7,8-CDFs) multiplied by their respective toxicity factors, as shown in the table below.

Isomer Group	Toxicity Equivalence Factor
2,3,7,8-tetra CDD	1.0
2,3,7,8-penta CDD	0.5
2,3,7,8-hexa CDDs	0.1
2,3,7,8-hepta CDD	0.01
octa CDD	0.001
2,3,7,8 tetra CDF	0.1
1,2,3,7,8 penta CDF	0.05
2,3,4,7,8 penta CDF	0.5
2,3,7,8 hexa CDFs	0.1
2,3,7,8 hepta CDFs	0.01
octa CDF	0.001

**Toxicity Reduction Evaluation (TRE)** is a study conducted in a step-wise process designed to identify the causative agents of effluent or ambient toxicity, isolate the sources of toxicity, evaluate the effectiveness of toxicity control options, and then confirm the reduction in toxicity. The first steps of the TRE consist of the collection of data relevant to the toxicity, including additional toxicity testing, and an evaluation of facility operations and maintenance practices, and best management practices. A TOXICITY IDENTIFICATION EVALUATION (TIE) may be required as part of the TRE, if appropriate. (A TIE is a set of procedures to identify the specific chemical(s) responsible for toxicity. These procedures are performed in three phases (characterization, identification, and confirmation) using aquatic organism toxicity tests.)

**Waste:** As used in the Ocean Plan, waste includes a Discharger’s total discharge, of whatever origin, i.e., gross, not net, discharge.

**Water Reclamation:** The treatment of wastewater to render it suitable for reuse, the transportation of treated wastewater to the place of use, and the actual use of treated wastewater for a direct beneficial use or controlled use that would not otherwise occur.

Attachment B – MAP

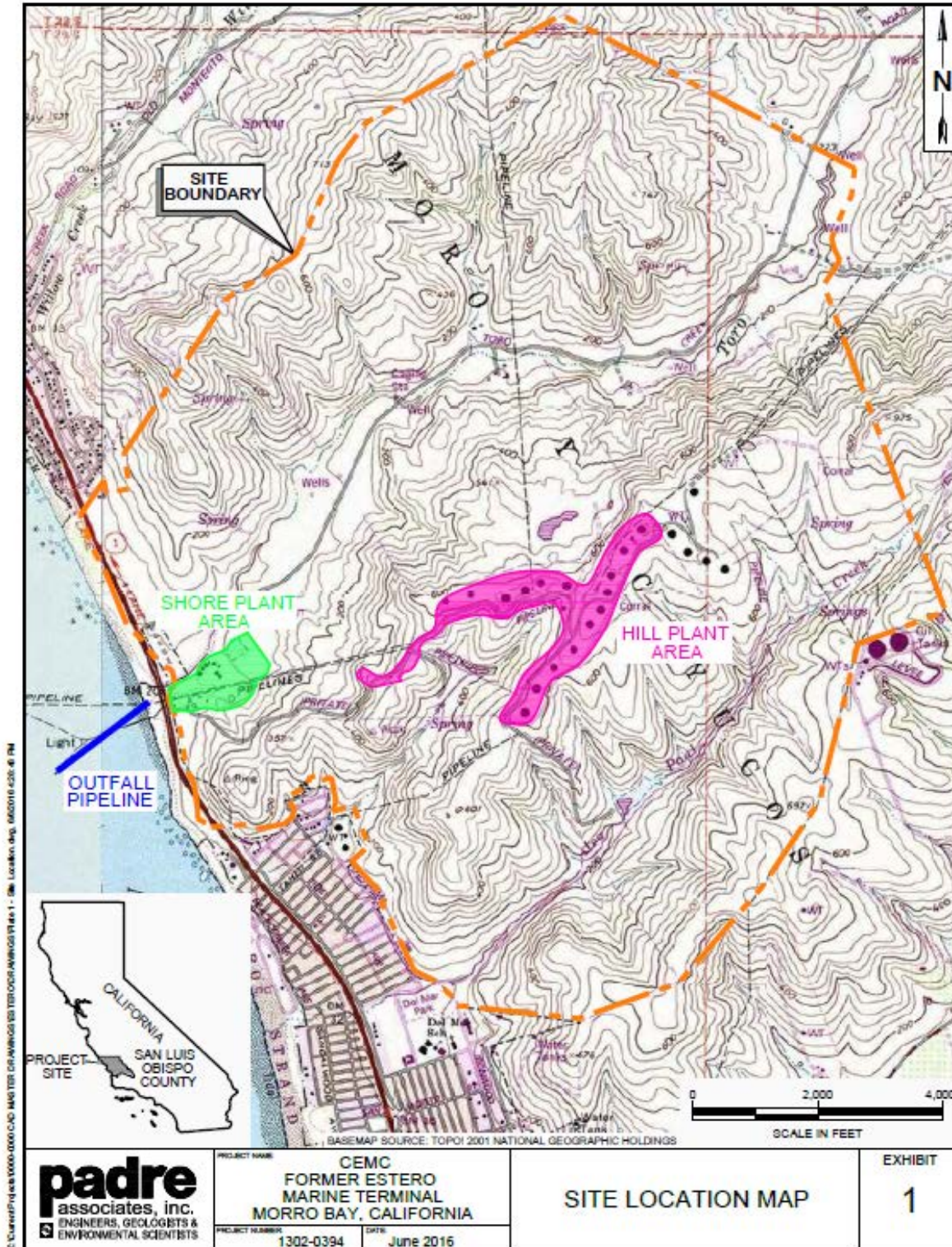



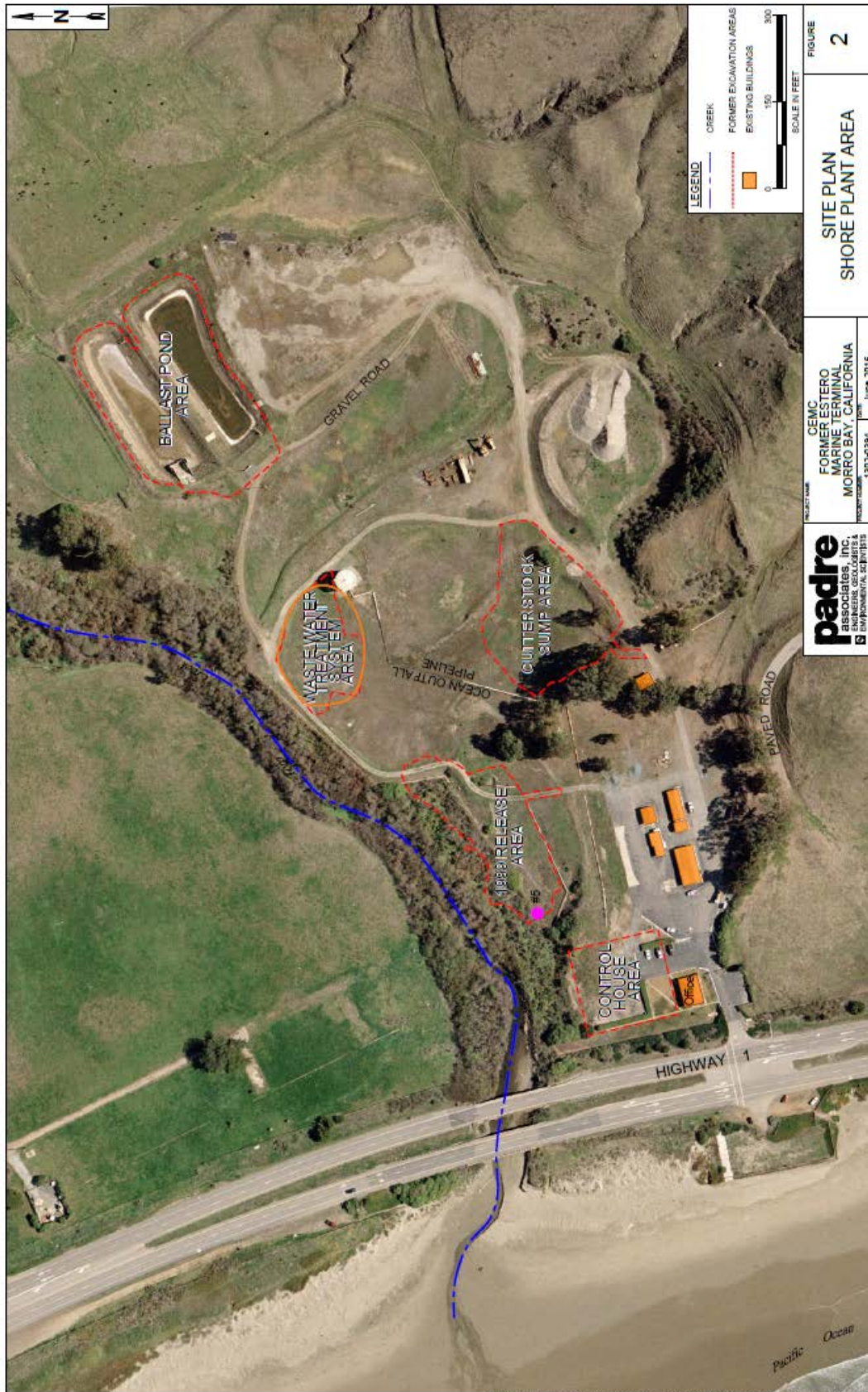

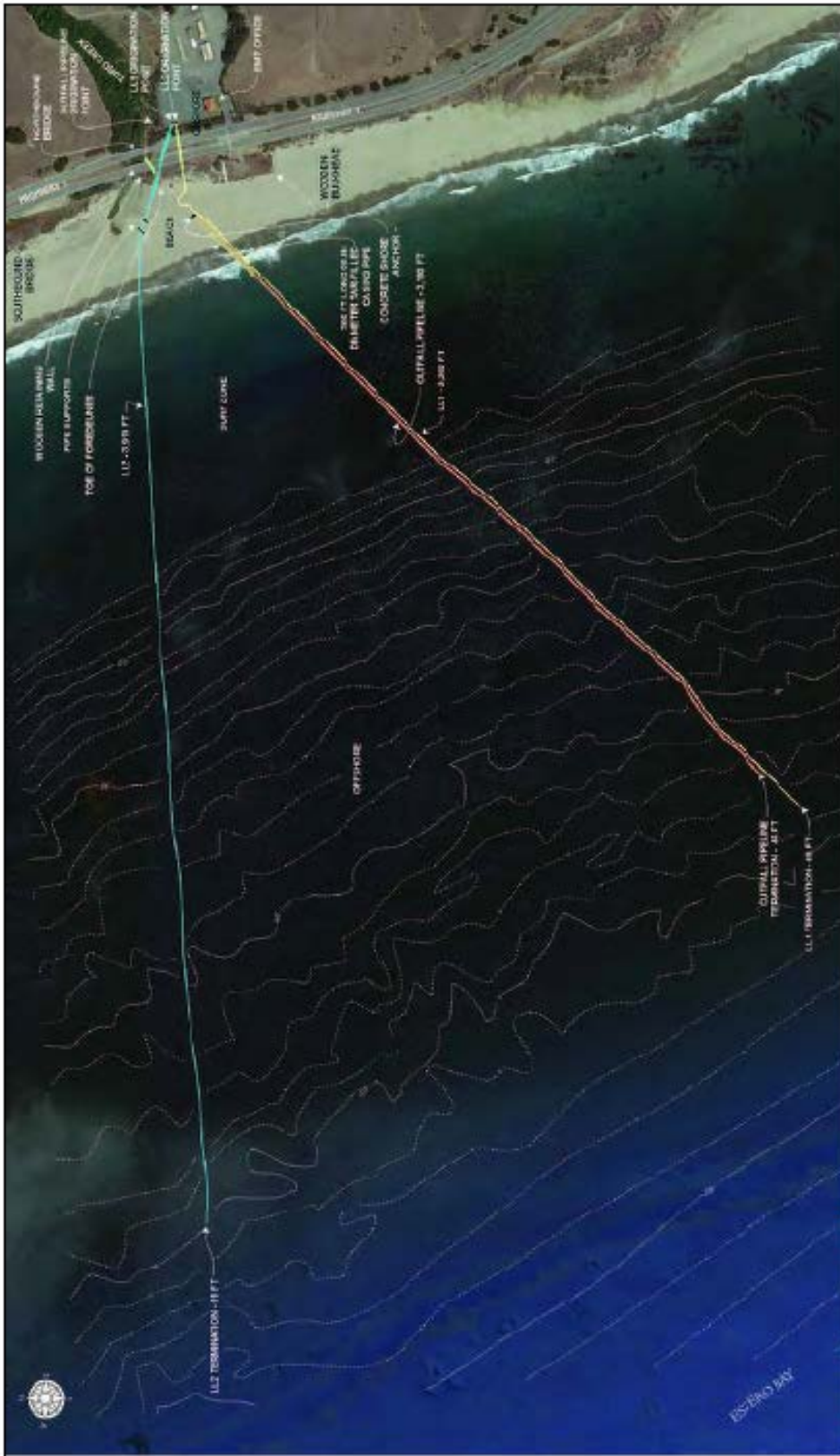

Base Map Source: Longitude 123

<p><b>padre</b>          ASSOCIATES, INC.          ENGINEERS, GEOLOGISTS &amp;          ENVIRONMENTAL SCIENTISTS</p>	PROJECT NAME CEMIC FORMER ESTERO MARINE TERMINAL MORRO BAY, CALIFORNIA	DATE June 2016
	PROJECT NUMBER 1302-0394	FIGURE 4



**Attachment C – Flow Schematic**

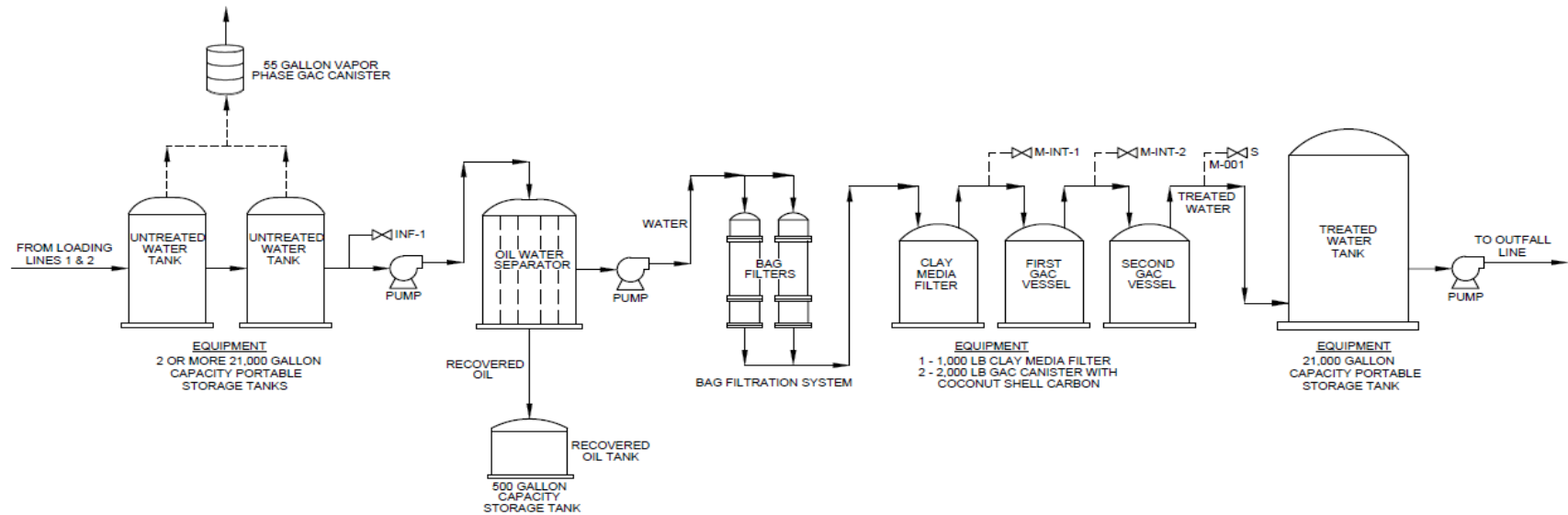

PROCESS FLOW DIAGRAM - 200 GPM

LEGEND

- LIQUID
- - - VAPOR
- ⊗ SAMPLE COLLECTION PORTS



## **Attachment D –Standard Provisions**

### **I. Standard Provisions – Permit Compliance**

#### **A. Duty to Comply**

1. The Discharger must comply with all of the conditions of this Order. Any noncompliance constitutes a violation of the Clean Water Act (CWA) and the California Water Code (CWC) and is grounds for enforcement action, for permit termination, revocation and reissuance, or modification; or denial of a permit renewal application. (40 CFR §122.41(a).)
2. The Discharger shall comply with effluent standards or prohibitions established under CWA §307(a) for toxic pollutants and with standards for sewage sludge use or disposal established under CWA §405(d) within the time provided in the regulations that establish these standards or prohibitions, even if this Order has not yet been modified to incorporate the requirement. (40 CFR §122.41(a)(1).)

#### **B. Need to Halt or Reduce Activity Not a Defense**

It shall not be a defense for a Discharger in an enforcement action that it would have been necessary to halt or reduce the permitted activity in order to maintain compliance with the conditions of this Order. (40 CFR § 22.41(c).)

#### **C. Duty to Mitigate**

The Discharger shall take all reasonable steps to minimize or prevent any discharge or sludge use or disposal in violation of this Order that has a reasonable likelihood of adversely affecting human health or the environment. (40 CFR §122.41(d).)

#### **D. Proper Operation and Maintenance**

The Discharger shall at all times properly operate and maintain all facilities and systems of treatment and control (and related appurtenances) which are installed or used by the Discharger to achieve compliance with the conditions of this Order. Proper operation and maintenance also includes adequate laboratory controls and appropriate quality assurance procedures. This provision requires the operation of backup or auxiliary facilities or similar systems that are installed by a Discharger only when necessary to achieve compliance with the conditions of this Order. (40 CFR §122.41(e).)

#### **E. Property Rights**

1. This Order does not convey any property rights of any sort or any exclusive privileges. (40 CFR §122.41(g).)
2. The issuance of this Order does not authorize any injury to persons or property or invasion of other private rights, or any infringement of state or local law or regulations. (40 CFR §122.5(c).)

## F. Inspection and Entry

The Discharger shall allow the Central Coast Water Board, State Water Board, USEPA, and/or their authorized representatives (including an authorized contractor acting as their representative), upon the presentation of credentials and other documents, as may be required by law, to (40 CFR §122.41(i); CWC §13383):

1. Enter upon the Discharger's premises where a regulated facility or activity is located or conducted, or where records are kept under the conditions of this Order (40 CFR §122.41(i)(1));
2. Have access to and copy, at reasonable times, any records that must be kept under the conditions of this Order (40 CFR §122.41(i)(2));
3. Inspect and photograph, at reasonable times, any facilities, equipment (including monitoring and control equipment), practices, or operations regulated or required under this Order (40 CFR §122.41(i)(3)); and
4. Sample or monitor, at reasonable times, for the purposes of assuring Order compliance or as otherwise authorized by the CWA or CWC, any substances or parameters at any location. (40 CFR §122.41(i)(4).)

## G. Bypass

1. Definitions
  - a. "Bypass" means the intentional diversion of waste streams from any portion of a treatment facility. (40 CFR §122.41(m)(1)(i).)
  - b. "Severe property damage" means substantial physical damage to property, damage to the treatment facilities, which causes them to become inoperable, or substantial and permanent loss of natural resources that can reasonably be expected to occur in the absence of a bypass. Severe property damage does not mean economic loss caused by delays in production. (40 CFR §122.41(m)(1)(ii).)
2. Bypass not exceeding limitations. The Discharger may allow any bypass to occur which does not cause exceedances of effluent limitations, but only if it is for essential maintenance to assure efficient operation. These bypasses are not subject to the provisions listed in Standard Provisions – Permit Compliance I.G.3, I.G.4, and I.G.5 below. (40 CFR §122.41(m)(2).)
3. Prohibition of bypass. Bypass is prohibited, and the Central Coast Water Board may take enforcement action against a Discharger for bypass, unless (40 CFR §122.41(m)(4)(i)):
  - a. Bypass was unavoidable to prevent loss of life, personal injury, or severe property damage (40 CFR §122.41(m)(4)(i)(A));



- b. There were no feasible alternatives to the bypass, such as the use of auxiliary treatment facilities, retention of untreated wastes, or maintenance during normal periods of equipment downtime. This condition is not satisfied if adequate back-up equipment should have been installed in the exercise of reasonable engineering judgment to prevent a bypass that occurred during normal periods of equipment downtime or preventive maintenance (40 CFR §122.41(m)(4)(i)(B)); and
    - c. The Discharger submitted notice to the Central Coast Water Board as required under Standard Provisions – Permit Compliance I.G.5 below. (40 CFR §122.41(m)(4)(i)(C).)
  4. The Central Coast Water Board may approve an anticipated bypass, after considering its adverse effects, if the Central Coast Water Board determines that it will meet the three conditions listed in Standard Provisions – Permit Compliance I.G.3 above. (40 CFR §122.41(m)(4)(ii).)
5. Notice
  - a. Anticipated bypass. If the Discharger knows in advance of the need for a bypass, it shall submit a notice, if possible at least 10 days before the date of the bypass. (40 CFR §122.41(m)(3)(i).)
  - b. Unanticipated bypass. The Discharger shall submit notice of an unanticipated bypass as required in Standard Provisions - Reporting V.E below (24-hour notice). (40 CFR §122.41(m)(3)(ii).)

## H. Upset

Upset means an exceptional incident in which there is unintentional and temporary noncompliance with technology based permit effluent limitations because of factors beyond the reasonable control of the Discharger. An upset does not include noncompliance to the extent caused by operational error, improperly designed treatment facilities, inadequate treatment facilities, lack of preventive maintenance, or careless or improper operation. (40 CFR §122.41(n)(1).)

1. Effect of an upset. An upset constitutes an affirmative defense to an action brought for noncompliance with such technology based permit effluent limitations if the requirements of Standard Provisions – Permit Compliance I.H.2 below are met. No determination made during administrative review of claims that noncompliance was caused by upset, and before an action for noncompliance, is final administrative action subject to judicial review. (40 CFR §122.41(n)(2).)
2. Conditions necessary for a demonstration of upset. A Discharger who wishes to establish the affirmative defense of upset shall demonstrate, through properly signed, contemporaneous operating logs or other relevant evidence that (40 CFR §122.41(n)(3)):

- a. An upset occurred and that the Discharger can identify the cause(s) of the upset (40 CFR §122.41(n)(3)(i));
  - b. The permitted facility was, at the time, being properly operated (40 CFR §122.41(n)(3)(ii));
  - c. The Discharger submitted notice of the upset as required in Standard Provisions – Reporting V.E.2.b below (24-hour notice) (40 CFR §122.41(n)(3)(iii)); and
  - d. The Discharger complied with any remedial measures required under Standard Provisions – Permit Compliance I.C above. (40 CFR §122.41(n)(3)(iv).)
3. Burden of proof. In any enforcement proceeding, the Discharger seeking to establish the occurrence of an upset has the burden of proof. (40 CFR §122.41(n)(4).)

## **II. Standard Provisions – Permit Action**

### **A. General**

This Order may be modified, revoked and reissued, or terminated for cause. The filing of a request by the Discharger for modification, revocation and reissuance, or termination, or a notification of planned changes or anticipated noncompliance does not stay any Order condition. (40 CFR §122.41(f).)

### **B. Duty to Reapply**

If the Discharger wishes to continue an activity regulated by this Order after the expiration date of this Order, the Discharger must apply for and obtain a new permit. (40 CFR §122.41(b).)

### **C. Transfers**

This Order is not transferable to any person except after notice to the Central Coast Water Board. The Central Coast Water Board may require modification or revocation and reissuance of the Order to change the name of the Discharger and incorporate such other requirements as may be necessary under the CWA and the CWC. (40 CFR § 122.41(l)(3); §122.61.)

### III. Standard Provisions – Monitoring

- A. Samples and measurements taken for the purpose of monitoring shall be representative of the monitored activity. (40 CFR §122.41(j)(1).)
- B. Monitoring results must be conducted according to test procedures under Part 136 or, in the case of sludge use or disposal, approved under Part 136 unless otherwise specified in Part 503 unless other test procedures have been specified in this Order. (40 CFR § 122.41(j)(4); §122.44(i)(1)(iv).)

### IV. Standard Provisions – Records

- A. Except for records of monitoring information required by this Order related to the Discharger's sewage sludge use and disposal activities, which shall be retained for a period of at least five years (or longer as required by Part 503), the Discharger shall retain records of all monitoring information, including all calibration and maintenance records and all original strip chart recordings for continuous monitoring instrumentation, copies of all reports required by this Order, and records of all data used to complete the application for this Order, for a period of at least three (3) years from the date of the sample, measurement, report or application. This period may be extended by request of the Central Coast Water Board Executive Officer at any time. (40 CFR §122.41(j)(2).)

#### B. Records of monitoring information shall include:

1. The date, exact place, and time of sampling or measurements (40 CFR §122.41(j)(3)(i));
2. The individual(s) who performed the sampling or measurements (40 CFR §122.41(j)(3)(ii));
3. The date(s) analyses were performed (40 CFR §122.41(j)(3)(iii));
4. The individual(s) who performed the analyses (40 CFR §122.41(j)(3)(iv));
5. The analytical techniques or methods used (40 CFR §122.41(j)(3)(v)); and
6. The results of such analyses. (40 CFR §122.41(j)(3)(vi).)

#### C. Claims of confidentiality for the following information will be denied (40 CFR §122.7(b)):

1. The name and address of any permit applicant or Discharger (40 CFR §122.7(b)(1)); and
2. Permit applications and attachments, permits and effluent data. (40 CFR §122.7(b)(2).)

## V. Standard Provisions – Reporting

### A. Duty to Provide Information

The Discharger shall furnish to the Central Coast Water Board, State Water Board, or USEPA within a reasonable time, any information which the Central Coast Water Board, State Water Board, or USEPA may request to determine whether cause exists for modifying, revoking and reissuing, or terminating this Order or to determine compliance with this Order. Upon request, the Discharger shall also furnish to the Central Coast Water Board, State Water Board, or USEPA copies of records required to be kept by this Order. (40 CFR §122.41(h); CWC §13267.)

### B. Signatory and Certification Requirements

1. All applications, reports, or information submitted to the Central Coast Water Board, State Water Board, and/or USEPA shall be signed and certified in accordance with Standard Provisions – Reporting V.B.2, V.B.3, V.B.4, and V.B.5 below. (40 CFR §122.41(k).)
2. All permit applications shall be signed by either a principal executive officer or ranking elected official. For purposes of this provision, a principal executive officer of a federal agency includes: (i) the chief executive officer of the agency, or (ii) a senior executive officer having responsibility for the overall operations of a principal geographic unit of the agency (e.g., Regional Administrators of USEPA). (40 CFR §122.22(a)(3).)
3. All reports required by this Order and other information requested by the Central Coast Water Board, State Water Board, or USEPA shall be signed by a person described in Standard Provisions – Reporting V.B.2 above, or by a duly authorized representative of that person. A person is a duly authorized representative only if:
  - a. The authorization is made in writing by a person described in Standard Provisions – Reporting V.B.2 above (40 CFR §122.22(b)(1));
  - b. The authorization specifies either an individual or a position having responsibility for the overall operation of the regulated facility or activity such as the position of plant manager, operator of a well or a well field, superintendent, position of equivalent responsibility, or an individual or position having overall responsibility for environmental matters for the company. (A duly authorized representative may thus be either a named individual or any individual occupying a named position.) (40 CFR §122.22(b)(2)); and
  - c. The written authorization is submitted to the Central Coast Water Board and State Water Board. (40 CFR §122.22(b)(3).)
4. If an authorization under Standard Provisions – Reporting V.B.3 above is no longer accurate because a different individual or position has responsibility for the overall operation of the facility, a new authorization satisfying the requirements of Standard Provisions – Reporting V.B.3 above must be submitted to the Central Coast Water

Board and State Water Board prior to or together with any reports, information, or applications, to be signed by an authorized representative. (40 CFR §122.22(c).)

5. Any person signing a document under Standard Provisions – Reporting V.B.2 or V.B.3 above shall make the following certification:

“I certify under penalty of law that this document and all attachments were prepared under my direction or supervision in accordance with a system designed to assure that qualified personnel properly gather and evaluate the information submitted. Based on my inquiry of the person or persons who manage the system or those persons directly responsible for gathering the information, the information submitted is, to the best of my knowledge and belief, true, accurate, and complete. I am aware that there are significant penalties for submitting false information, including the possibility of fine and imprisonment for knowing violations.” (40 CFR §122.22(d).)

### **C. Monitoring Reports**

1. Monitoring results shall be reported at the intervals specified in the Monitoring and Reporting Program (Attachment E) in this Order. (40 CFR §122.41(l)(4).)
2. Monitoring results must be reported on a Discharge Monitoring Report (DMR) form or forms provided or specified by the Central Coast Water Board or State Water Board for reporting results of monitoring of sludge use or disposal practices. (40 CFR §122.41(l)(4)(i).)
3. If the Discharger monitors any pollutant more frequently than required by this Order using test procedures approved under Part 136 or, in the case of sludge use or disposal, approved under Part 136 unless otherwise specified in Part 503, or as specified in this Order, the results of this monitoring shall be included in the calculation and reporting of the data submitted in the DMR or sludge reporting form specified by the Central Coast Water Board. (40 CFR §122.41(l)(4)(ii).)
4. Calculations for all limitations, which require averaging of measurements, shall utilize an arithmetic mean unless otherwise specified in this Order. (40 CFR §122.41(l)(4)(iii).)

### **D. Compliance Schedules**

Reports of compliance or noncompliance with, or any progress reports on, interim and final requirements contained in any compliance schedule of this Order, shall be submitted no later than 14 days following each schedule date. (40 CFR §122.41(l)(5).)

### **E. Twenty-Four Hour Reporting**

1. The Discharger shall report any noncompliance that may endanger health or the environment. Any information shall be provided orally within 24 hours from the time the Discharger becomes aware of the circumstances. A written submission shall also be provided within five (5) days of the time the Discharger becomes aware of the circumstances. The written submission shall contain a description of the

noncompliance and its cause; the period of noncompliance, including exact dates and times, and if the noncompliance has not been corrected, the anticipated time it is expected to continue; and steps taken or planned to reduce, eliminate, and prevent reoccurrence of the noncompliance. (40 CFR §122.41(l)(6)(i).)

2. The following shall be included as information that must be reported within 24 hours under this paragraph (40 CFR §122.41(l)(6)(ii)):
  - a. Any unanticipated bypass that exceeds any effluent limitation in this Order. (40 CFR §122.41(l)(6)(ii)(A).)
  - b. Any upset that exceeds any effluent limitation in this Order. (40 CFR §122.41(l)(6)(ii)(B).)
3. The Central Coast Water Board may waive the above-required written report under this provision on a case-by-case basis if an oral report has been received within 24 hours. (40 CFR §122.41(l)(6)(iii).)

#### **F. Planned Changes**

The Discharger shall give notice to the Central Coast Water Board as soon as possible of any planned physical alterations or additions to the permitted facility. Notice is required under this provision only when (40 CFR §122.41(l)(1)):

1. The alteration or addition to a permitted facility may meet one of the criteria for determining whether a facility is a new source in section 122.29(b) (40 CFR §122.41(l)(1)(i)); or
2. The alteration or addition could significantly change the nature or increase the quantity of pollutants discharged. This notification applies to pollutants that are not subject to effluent limitations in this Order. (40 CFR §122.41(l)(1)(ii).)
3. The alteration or addition results in a significant change in the Discharger's sludge use or disposal practices, and such alteration, addition, or change may justify the application of permit conditions that are different from or absent in the existing permit, including notification of additional use or disposal sites not reported during the permit application process or not reported pursuant to an approved land application plan. (40 CFR §122.41(l)(1)(iii).)

#### **G. Anticipated Noncompliance**

The Discharger shall give advance notice to the Central Coast Water Board or State Water Board of any planned changes in the permitted facility or activity that may result in noncompliance with General Order requirements. (40 CFR §122.41(l)(2).)

#### **H. Other Noncompliance**

The Discharger shall report all instances of noncompliance not reported under Standard Provisions – Reporting V.C, V.D, and V.E above at the time monitoring reports are

submitted. The reports shall contain the information listed in Standard Provision – Reporting V.E above. (40 CFR §122.41(l)(7).)

#### **I. Other Information**

When the Discharger becomes aware that it failed to submit any relevant facts in a permit application, or submitted incorrect information in a permit application or in any report to the Central Coast Water Board, State Water Board, or USEPA, the Discharger shall promptly submit such facts or information. (40 CFR §122.41(l)(8).)

#### **VI. Standard Provisions – Enforcement**

- A.** The Central Coast Water Board is authorized to enforce the terms of this permit under several provisions of the CWC, including, but not limited to, §13385, §13386, and §13387.

#### **VII. Additional Provisions – Notification Levels**

##### **A. Publicly Owned Treatment Works (POTWs)**

All POTWs shall provide adequate notice to the Central Coast Water Board of the following (40 CFR §122.42(b)):

1. Any new introduction of pollutants into the POTW from an indirect discharger that would be subject to sections 301 or 306 of the CWA if it were directly discharging those pollutants (40 CFR §122.42(b)(1)); and
2. Any substantial change in the volume or character of pollutants being introduced into that POTW by a source introducing pollutants into the POTW at the time of adoption of the Order. (40 CFR §122.42(b)(2).)
3. Adequate notice shall include information on the quality and quantity of effluent introduced into the POTW as well as any anticipated impact of the change on the quantity or quality of effluent to be discharged from the POTW. (40 CFR §122.42(b)(3).)

## **Attachment D-1 - CENTRAL COAST WATER BOARD STANDARD PROVISIONS (January 2013)**

### **I. Central Coast General Permit Conditions**

#### **A. Central Coast Standard Provisions – Prohibitions**

1. Introduction of "incompatible wastes" to the treatment system is prohibited.
2. Discharge of high-level radiological waste and of radiological, chemical, and biological warfare agents is prohibited.
3. Discharge of "toxic pollutants" in violation of effluent standards and prohibitions established under CWA §307(a) is prohibited.
4. Discharge of sludge, sludge digester or thickener supernatant, and sludge drying bed leachate to drainageways, surface waters, or the ocean is prohibited.
5. Introduction of pollutants into the collection, treatment, or disposal system by an "indirect discharger" that:
  - a. Inhibit or disrupt the treatment process, system operation, or the eventual use or disposal of sludge; or,
  - b. Flow through the system to the receiving water untreated; and,
  - c. Cause or "significantly contribute" to a violation of any requirement of this Order, is prohibited.
6. Introduction of "pollutant free" wastewater to the collection, treatment, and disposal system in amounts that threaten compliance with this order is prohibited.

#### **B. Central Coast Standard Provisions – Provisions**

1. Collection, treatment, and discharge of waste shall not create a nuisance or pollution, as defined by CWC §13050 .
2. All facilities used for transport or treatment of wastes shall be adequately protected from inundation and washout as the result of a 100-year frequency flood.
3. Operation of collection, treatment, and disposal systems shall be in a manner that precludes public contact with wastewater.
4. Collected screenings, sludges, and other solids removed from liquid wastes shall be disposed in a manner approved by the Executive Officer.
5. Wastewater treatment plants shall be supervised and operated by persons possessing certificates of appropriate grade pursuant to Title 23 of the California Code of Regulations.



6. After notice and opportunity for a hearing, this order may be terminated for cause, including, but not limited to:
  - a. violation of any term or condition contained in this order;
  - b. obtaining this order by misrepresentation, or by failure to disclose fully all relevant facts;
  - c. a change in any condition or endangerment to human health or environment that requires a temporary or permanent reduction or elimination of the authorized discharge; and,
  - d. a substantial change in character, location, or volume of the discharge.
7. Provisions of this permit are severable. If any provision of the permit is found invalid, the remainder of the permit shall not be affected.
8. After notice and opportunity for hearing, this order may be modified or revoked and reissued for cause, including:
  - a. Promulgation of a new or revised effluent standard or limitation;
  - b. A material change in character, location, or volume of the discharge;
  - c. Access to new information that affects the terms of the permit, including applicable schedules;
  - d. Correction of technical mistakes or mistaken interpretations of law; and,
  - e. Other causes set forth under Sub-part D of 40 CFR Part 122.
9. Safeguards shall be provided to assure maximal compliance with all terms and conditions of this permit. Safeguards shall include preventative and contingency plans and may also include alternative power sources, stand-by generators, retention capacity, operating procedures, or other precautions. Preventative and contingency plans for controlling and minimizing the effect of accidental discharges shall:
  - a. identify possible situations that could cause "upset", "overflow" or "bypass", or other noncompliance. (Loading and storage areas, power outage, waste treatment unit outage, and failure of process equipment, tanks and pipes should be considered.)
  - b. evaluate the effectiveness of present facilities and procedures and describe procedures and steps to minimize or correct any adverse environmental impact resulting from noncompliance with the permit.
10. Physical Facilities shall be designed and constructed according to accepted engineering practice and shall be capable of full compliance with this order when properly operated and maintained. Proper operation and maintenance shall be

described in an Operation and Maintenance Manual. Facilities shall be accessible during the wet-weather season.

11. The discharger shall at all times properly operate and maintain all facilities and systems of treatment and control (and related appurtenances) that are installed or used by the discharger to achieve compliance with the conditions of this order. Electrical and mechanical equipment shall be maintained in accordance with appropriate practices and standards, such as NFPA 70B, *Recommended Practice for Electrical Equipment Maintenance*; NFPA 70E, *Standard for Electrical Safety in the Workplace*; ANSI/NETA MTS *Standard for Maintenance: Testing Specifications for Electrical Power Equipment and Systems*, or procedures established by insurance companies or other industry resources.
12. If the discharger's facilities are equipped with SCADA or other systems that implement wireless, remote operation, the discharger should implement appropriate safeguards against unauthorized access to the wireless systems. Standards such as NIST SP 800-53, *Recommended Security Controls for Federal Information Systems*, can provide guidance.
13. Production and use of recycled water is subject to the approval of the Central Coast Board. Production and use of recycled water shall be in conformance with reclamation criteria established in Chapter 3, Title 22, of the California Code of Regulations and CWC, Chapter 7, Division 7. An engineering report pursuant to §60323, Title 22, of the California Code of Regulations is required and a waiver or water reclamation requirements from the Central Coast Water Board is required before reclaimed water is supplied for any use, or to any user, not specifically identified and approved either in this Order or another order issued by this Board.

### **C. Central Coast Standard Provisions – General Monitoring Requirements**

1. If results of monitoring a pollutant appear to violate effluent limitations based on a weekly, monthly, 30-day, or six-month period, but compliance or non-compliance cannot be validated because sampling is too infrequent, the frequency of sampling shall be increased to validate the test within the next monitoring period. The increased frequency shall be maintained until the Executive Officer agrees the original monitoring frequency may be resumed.

For example, if copper is monitored annually and results exceed the six-month median numerical effluent limitation in the permit, monitoring of copper must be increased to a frequency of at least once every two months (Central Coast Standard Provisions – Definitions I.G.13.). If suspended solids are monitored weekly and results exceed the weekly average numerical limit in the permit, monitoring of suspended solids must be increased to at least four (4) samples every week (Central Coast Standard Provisions – Definitions I.G.14.).

2. Water quality analyses performed in order to monitor compliance with this permit shall be by a laboratory certified by the State Department of Public Health for the constituent(s) being analyzed. Bioassay(s) performed in order to monitor compliance

with this permit shall be in accord with guidelines approved by the State Water Board and the State Department of Fish and Game

3. Samples and measurements taken for the purpose of monitoring shall be representative of the monitored activity. Samples shall be taken during periods of peak loading conditions. Influent samples shall be samples collected from the combined flows of all incoming wastes, excluding recycled wastes. Effluent samples shall be samples collected downstream of the last treatment unit and tributary flow and upstream of any mixing with receiving waters.
4. All monitoring instruments and devices used by the discharger to fulfill the prescribed monitoring program shall be properly maintained and calibrated as necessary to ensure their continued accuracy.

#### **D. Central Coast Standard Provisions – General Pretreatment Provisions**

1. Discharge of pollutants by “indirect dischargers” in specific industrial sub-categories (appendix C, 40 CFR Part 403), where categorical pretreatment standards have been established, or are to be established, (according to 40 CFR Chapter 1, Subchapter N), shall comply with the appropriate pretreatment standards by the date specified therein.;

#### **E. Central Coast Standard Provisions – General Reporting Requirements**

1. Reports of marine monitoring surveys conducted to meet receiving water monitoring requirements of the Monitoring and Reporting Program shall include at least the following information:
  - a. A description of climatic and receiving water characteristics at the time of sampling (weather observations, floating debris, discoloration, wind speed and direction, swell or wave action, time of sampling, tide height, etc.).
  - b. A description of sampling stations, including differences unique to each station (e.g., station location, grain size, rocks, shell litter, calcareous worm tubes, evident life, etc.).
  - c. A description of the sampling procedures and preservation sequence used in the survey.
  - d. A description of the exact method used for laboratory analysis. In general, analysis shall be conducted according to Central Coast Standard Provisions – C.1 above, and Federal Standard Provision – Monitoring III.B. However, variations in procedure are acceptable to accommodate the special requirements of sediment analysis. All such variations must be reported with the test results.
  - e. A brief discussion of the results of the survey. The discussion shall compare data from the control station with data from the outfall stations. All tabulations and computations shall be explained.

2. Reports of compliance or noncompliance with, or any progress reports on, interim and final requirements contained in any compliance schedule shall be submitted within 14 days following each scheduled date unless otherwise specified within the permit. If reporting noncompliance, the report shall include a description of the reason, a description and schedule of tasks necessary to achieve compliance, and an estimated date for achieving full compliance. A second report shall be submitted within 14 days of full compliance.
3. The "Discharger" shall file a report of waste discharge Officer at least 180 days before making any material change or proposed change in the character, location, or plume of the discharge.
4. Within 120 days after the discharger discovers, or is notified by the Central Coast Water Board, that monthly average daily flow will or may reach design capacity of waste treatment and/or disposal facilities within four (4) years, the discharger shall file a written report with the Central Coast Water Board. The report shall include:
  - a. the best estimate of when the monthly average daily dry weather flow rate will equal or exceed design capacity; and,
  - b. a schedule for studies, design, and other steps needed to provide additional capacity for waste treatment and/or disposal facilities before the waste flow rate equals the capacity of present units.

In addition to complying with Federal Standard Provision – Reporting V.B., the required technical report shall be prepared with public participation and reviewed, approved and jointly submitted by all planning and building departments having jurisdiction in the area served by the waste collection, treatment, or disposal facilities.

5. All "Dischargers" shall submit reports electronically to the State Water Resources Control Board CIWQS database. If the database is unavailable, reports are to be sent electronically to the:

California Regional Water Quality Control Board  
Central Coast Region  
[centralcoast@waterboards.ca.gov](mailto:centralcoast@waterboards.ca.gov)  
895 Aerovista Place, Suite 101  
San Luis Obispo, CA 93401-7906

In addition, "Dischargers" with designated major discharges shall submit a copy of each document to the State Water Resources Control Board CIWQS database. If the database is unavailable, reports are to be sent electronically to the:

Regional Administrator  
US Environmental Protection Agency, Region 9  
Attention: CWA Standards and Permits Office (WTR-5)  
<https://cfpub.epa.gov/dmr/>

6. Transfer of control or ownership of a waste discharge facility must be preceded by a notice to the Central Coast Water Board at least 30 days in advance of the proposed transfer date. The notice must include a written agreement between the existing "Discharger" and proposed "Discharger" containing specific date for transfer of responsibility, coverage, and liability between them. Whether a permit may be transferred without modification or revocation and reissuance is at the discretion of the Central Coast Water Board. If permit modification or revocation and reissuance is necessary, transfer may be delayed 180 days after the Central Coast Water Board's receipt of a complete permit application. Please also see Federal Standard Provision – Permit Action II.C.
7. Except for data determined to be confidential under CWA §308 (excludes effluent data and permit applications), all reports prepared in accordance with this permit shall be available for public inspection at the office of the Central Coast Water Board or Central Coast Administrator of USEPA. Please also see Federal Standard Provision – Records IV.C.
8. By January 30th of each year, the discharger shall submit an annual report to the Central Coast Water Board. The report shall contain the following:
  - a) Both tabular and graphical summaries of the monitoring data obtained during the previous year.
  - b) A discussion of the previous year's compliance record and corrective actions taken, or which may be needed, to bring the discharger into full compliance.
  - c) An evaluation of wastewater flows with projected flow rate increases over time and the estimated date when flows will reach facility capacity.
  - d) A discussion of operator certification and a list of current operating personnel and their grades of certification.
  - e) The date of the facility's Operation and Maintenance Manual (including contingency plans as described in Provision B.9), the date the manual was last reviewed, and whether the manual is complete and valid for the current facility.
  - f) A discussion of the laboratories used by the discharger to monitor compliance with effluent limits and a summary of performance relative to Section C, General Monitoring Requirements.
  - g) If the facility treats industrial or domestic wastewater and there is no provision for periodic sludge monitoring in the Monitoring and Reporting Program, the report shall include a summary of sludge quantities, analyses of its chemical and moisture content, and its ultimate destination.
  - h) If appropriate, the report shall also evaluate the effectiveness of the local source control or pretreatment program using the State Water Resources Control Board's "Guidelines for Determining the Effectiveness of Local Pretreatment Program."

#### **F. Central Coast Standard Provisions – Enforcement**

1. Any person failing to file a report of waste discharge or other report as required by this permit shall be subject to a civil penalty not to exceed \$5,000 per day.

2. Upon reduction, loss, or failure of the treatment facility, the "Discharger" shall, to the extent necessary to maintain compliance with this permit, control production or all discharges, or both, until the facility is restored or an alternative method of treatment is provided.

## **G. Central Coast Standard Provisions – Definitions**

### **(Not otherwise included in Attachment A to this Order)**

1. A "composite sample" is a combination of no fewer than eight (8) individual samples obtained at equal time intervals (usually hourly) over the specified sampling (composite) period. The volume of each individual sample is proportional to the flow rate at the time of sampling. The period shall be specified in the Monitoring and Reporting Program ordered by the Executive Officer.
2. "Daily Maximum" limit means the maximum acceptable concentration or mass emission rate of a pollutant measured during a calendar day or during any 24-hour period reasonably representative of the calendar day for purposes of sampling. It is normally compared with results based on "composite samples" except for ammonia, total chlorine, phenolic compounds, and toxicity concentration. For all exceptions, comparisons will be made with results from a "grab sample".
3. "Discharger", as used herein, means, as appropriate: (1) the Discharger, (2) the local sewerage entity (when the collection system is not owned and operated by the Discharger), or (3) "indirect discharger" (where "Discharger" appears in the same paragraph as "indirect discharger", it refers to the discharger.)
4. "Duly Authorized Representative" is one where:
  - a. the authorization is made in writing by a person described in the signatory paragraph of Federal Standard Provision V.B.;
  - b. the authorization specifies either an individual or the occupant of a position having either responsibility for the overall operation of the regulated facility, such as the plant manager, or overall responsibility for environmental matters of the company; and,
  - c. the written authorization was submitted to the Central Coast Water Board.
5. A "grab sample" is defined as any individual sample collected in less than 15 minutes. "Grab samples" shall be collected during peak loading conditions, which may or may not be during hydraulic peaks. It is used primarily in determining compliance with the daily maximum limits identified in Central Coast Standard Provision – Provision G.2. and instantaneous maximum limits.
6. "Hazardous substance" means any substance designated under 40 CFR Part 116 pursuant to Section 311 of the Clean Water Act.
7. "Incompatible wastes" are:

- a. Wastes which create a fire or explosion hazard in the treatment works;
  - b. Wastes which will cause corrosive structural damage to treatment works or wastes with a pH lower than 5.0 unless the works is specifically designed to accommodate such wastes;
  - c. Solid or viscous wastes in amounts which cause obstruction to flow in sewers, or which cause other interference with proper operation of treatment works;
  - d. Any waste, including oxygen demanding pollutants (BOD, etc.), released in such volume or strength as to cause inhibition or disruption in the treatment works and subsequent treatment process upset and loss of treatment efficiency; and,
  - e. Heat in amounts that inhibit or disrupt biological activity in the treatment works or that raise influent temperatures above 40°C (104°F) unless the treatment works is designed to accommodate such heat.
8. "Indirect Discharger" means a non-domestic discharger introducing pollutants into a publicly owned treatment and disposal system.
9. "Log Mean" is the geometric mean. Used for determining compliance of fecal or total coliform populations, it is calculated with the following equation:

$$\text{Log Mean} = (C_1 \times C_2 \times \dots \times C_n)^{1/n},$$

in which "n" is the number of days samples were analyzed during the period and any "C" is the concentration of bacteria (MPN/100 ml) found on each day of sampling. "n" should be five or more.

10. "Mass emission rate" is a daily rate defined by the following equations:

$$\text{mass emission rate (lbs/day)} = 8.34 \times Q \times C; \text{ and,}$$

$$\text{mass emission rate (kg/day)} = 3.79 \times Q \times C,$$

where "C" (in mg/l) is the measured daily constituent concentration or the average of measured daily constituent concentrations and "Q" (in MGD) is the measured daily flow rate or the average of measured daily flow rates over the period of interest.

11. The "Maximum Allowable Mass Emission Rate," whether for a month, week, day, or six-month period, is a daily rate determined with the formulas in paragraph G.10, above, using the effluent concentration limit specified in the permit for the period and the average of measured daily flows (up to the allowable flow) over the period.
12. "Maximum Allowable Six-Month Median Mass Emission Rate" is a daily rate determined with the formulas in Central Coast Standard Provision – Provision G.10, above, using the "six-month Median" effluent limit specified in the permit, and the average of measured daily flows (up to the allowable flow) over a 180-day period.

13. "Median" is the value below which half the samples (ranked progressively by increasing value) fall. It may be considered the middle value, or the average of two middle values.
14. "Monthly Average" (or "Weekly Average", as the case may be) is the arithmetic mean of daily concentrations or of daily mass emission rates over the specified 30-day (or 7-day) period.

$$\text{Average} = (X_1 + X_2 + \dots + X_n) / n$$

in which "n" is the number of days samples were analyzed during the period and "X" is either the constituent concentration (mg/l) or mass emission rate (kg/day or lbs/day) for each sampled day. "n" should be four or greater.

15. "Municipality" means a city, town, borough, county, district, association, or other public body created by or under state law and having jurisdiction over disposal of sewage, industrial waste, or other waste.
16. "Overflow" means the intentional or unintentional diversion of flow from the collection and transport systems, including pumping facilities.
17. "Pollutant-free wastewater" means inflow and infiltration, storm waters, and cooling waters and condensates which are essentially free of pollutants.
18. "Primary Industry Category" means any industry category listed in 40 CFR Part 122, Appendix A.
19. "Removal Efficiency" is the ratio of pollutants removed by the treatment unit to pollutants entering the treatment unit. Removal efficiencies of a treatment plant shall be determined using "Monthly averages" of pollutant concentrations (C, in mg/l) of influent and effluent samples collected about the same time and the following equation (or its equivalent):

$$C_{\text{Effluent}} \text{ Removal Efficiency (\%)} = 100 \times (1 - C_{\text{effluent}} / C_{\text{influent}})$$

20. "Severe property damage" means substantial physical damage to property, damage to treatment facilities which causes them to become inoperable, or substantial and permanent loss to natural resources which can reasonably be expected to occur in the absence of a "bypass". It does not mean economic loss caused by delays in production.
21. "Sludge" means the solids, residues, and precipitates separated from, or created in, wastewater by the unit processes of a treatment system.
22. To "significantly contribute" to a permit violation means an "indirect discharger" must:
  - a. Discharge a daily pollutant loading in excess of that allowed by contract with the "Discharger" or by Federal, State, or Local law;



- b. Discharge wastewater which substantially differs in nature or constituents from its average discharge;
  - c. Discharge pollutants, either alone or in conjunction with discharges from other sources, which results in a permit violation or prevents sewage sludge use or disposal; or
  - d. Discharge pollutants, either alone or in conjunction with pollutants from other sources that increase the magnitude or duration of permit violations.
23. "Toxic Pollutant" means any pollutant listed as toxic under Section 307 (a) (1) of the Clean Water Act or under 40 CFR Part 122, Appendix D. Violation of maximum daily discharge limitations are subject to 24-hour reporting (Federal Standard Provisions V.E.).
24. "Zone of Initial Dilution" means the region surrounding or adjacent to the end of an outfall pipe or diffuser ports whose boundaries are defined through calculation of a plume model verified by the State Water Board.

# Attachment E – Monitoring and Reporting Program

## Table of Contents

Attachment E – Monitoring and Reporting Program (MRP) .....	2
I. General Monitoring Provisions.....	2
II. Monitoring Locations .....	3
III. Influent Monitoring Requirements.....	4
IV. Effluent Monitoring Requirements .....	4
A. Monitoring Location M-001 .....	4
V. Internal Monitoring Requirements.....	7
A. Monitoring Locations M-INT-1 and M-INT-2.....	7
VI. Whole Effluent Toxicity Testing Requirements .....	8
VII. Land Discharge Monitoring Requirements – Not Applicable .....	11
VIII. Reclamation Monitoring Requirements – Not Applicable.....	11
IX. Receiving Water Monitoring Requirements – Not Applicable .....	11
X. Other Monitoring Requirements.....	11
A. Ocean Outfall Inspection.....	11
XI. Reporting Requirements.....	11
A. General Monitoring and Reporting Requirements.....	11
B. Self-Monitoring Reports (SMRs) .....	11
C. Discharge Monitoring Reports (DMRs) .....	14
D. Other Reports .....	14

## List of Tables

Table E-1. Monitoring Station Locations .....	3
Table E-2. Influent Monitoring at INF-001 .....	4
Table E-3. Major Constituents and Properties of Wastewater .....	4
Table E-4a. Effluent Monitoring, Ocean Plan Table B Pollutants – Protection of Marine Aquatic Life .....	4
Table E-4b. Effluent Monitoring, Ocean Plan Table B Pollutants – Protection of Human Health, Non-Carcinogens .....	5
Table E-4c. Effluent Monitoring, Ocean Plan Table B Pollutants – Protection of Human Health, Carcinogens .....	6
Table E-5. Internal Process Monitoring Constituents.....	7
Table E-6. Approved Tests – Chronic Toxicity.....	9
Table E-7. Monitoring Periods and Reporting Schedule .....	12

## Attachment E – Monitoring and Reporting Program (MRP)

The Code of Federal Regulations (CFR) §122.48 require that all NPDES permits specify monitoring and reporting requirements. California Water Code (CWC) 1§3267 and §13383 also authorize the Central Coast Regional Water Quality Control Board (Central Coast Water Board) to require technical and monitoring reports. This MRP establishes monitoring and reporting requirements, which implement the federal and California regulations.

### I. General Monitoring Provisions

- A. Laboratories analyzing monitoring samples shall be certified by the California Department of Public Health (DPH), in accordance with CWC §13176, and must include quality assurance/quality control data with their reports.
- B. Samples and measurements taken as required herein shall be representative of the volume and nature of the monitored discharge. All samples shall be taken at the monitoring locations specified below and, unless otherwise specified, before the monitored flow joins or is diluted by any other waste stream, body of water, or substance. Monitoring locations shall not be changed without notification to and approval of the Central Coast Water Board.
- C. Appropriate flow measurement devices and methods consistent with accepted scientific practices shall be selected and used to ensure the accuracy and reliability of measurements of the volume of monitored discharges. The devices shall be installed, calibrated, and maintained to ensure that the accuracy of the measurements is consistent with the accepted capability of that type of device. Devices selected shall be capable of measuring flows with a maximum deviation of less than  $\pm 10$  percent from true discharge rates throughout the range of expected discharge volumes. Guidance in selection, installation, calibration, and operation of acceptable flow measurement devices can be obtained from the following references.
  - 1. *A Guide to Methods and Standards for the Measurement of Water Flow, U.S. Department of Commerce, National Bureau of Standards, NBS Special Publication 421, May 1975, 96 pp. (Available from the U.S. Government Printing Office, Washington, D.C. 20402. Order by SD Catalog No. C13.10:421.)*
  - 2. *Water Measurement Manual, U.S. Department of Interior, Bureau of Reclamation, Second Edition, Revised Reprint, 1974, 327 pp. (Available from the U.S. Government Printing Office, Washington D.C. 20402. Order by Catalog No. 172.19/2:W29/2, Stock No. S/N 24003-0027.)*
  - 3. *Flow Measurement in Open Channels and Closed Conduits, U.S. Department of Commerce, National Bureau of Standards, NBS Special Publication 484, October 1977, 982 pp. (Available in paper copy or microfiche from National Technical Information Services (NTIS) Springfield, VA 22151. Order by NTIS No. PB-273 535/5ST.)*

4. *NPDES Compliance Sampling Manual, U.S. Environmental Protection Agency, Office of Water Enforcement, Publication MCD-51, 1977, 140 pp. (Available from the General Services Administration (8FFS), Centralized Mailing Lists Services, Building 41, Denver Federal Center, CO 80225.)*

- D. All monitoring instruments and devices used by the Discharger to fulfill the prescribed monitoring program shall be properly maintained and calibrated as necessary to ensure their continued accuracy. All flow measurement devices shall be calibrated at least once per year to ensure continued accuracy of the devices.
- E. Monitoring results, including noncompliance, shall be reported at intervals and in a manner specified in this MRP.
- F. Unless otherwise specified by this MRP, all monitoring shall be conducted according to test procedures established at 40 CFR 136, Guidelines Establishing Test Procedures for Analysis of Pollutants. All analyses shall be conducted using the lowest practical quantitation limit achievable using the specified methodology. Where effluent limitations are set below the lowest achievable quantitation limits, pollutants not detected at the lowest practical quantitation limits will be considered in compliance with effluent limitations. Analysis for toxics listed by the California Toxics Rule (CTR) shall also adhere to guidance and requirements contained in the Policy for Implementation of Toxics Standards for Inland Surface Waters, Enclosed Bays, and Estuaries of California (2005) (SIP). Analyses for toxics listed in Table B of the California Ocean Plan (2009) shall adhere to guidance and requirements contained in that document.

**II. Monitoring Locations**

The Discharger shall establish the following monitoring locations to demonstrate compliance with the effluent limitations, discharge specifications, and other requirements in this Order:

**Table E-1. Monitoring Station Locations**

Discharge Point Name	Monitoring Location Name	Monitoring Location Description
--	INF-001	At any location where a representative sample of untreated groundwater can be obtained prior to any treatment.
001	M-001	At any location where a representative sample of treated effluent can be obtained prior to discharge to the receiving water or commingling with additional wastewaters.
--	M-INT-1	At a location between the bag filters and the primary granular activated carbon (GAC) canister
--	M-INT-2	At a location between the primary and the redundant GAC canister

### III. Influent Monitoring Requirements

The Discharger shall monitor the untreated wastewater at INF-001 as follows:

**Table E-2. Influent Monitoring at INF-001**

Parameter	Units	Sample Type	Minimum Sampling Frequency	Required Analytical Test Method
Total Suspended Solids (TSS)	mg/L	Grab	1/Quarter	[1]

[1] As required under 40 CFR Part 136.

### IV. Effluent Monitoring Requirements

#### A. Monitoring Location M-001

- The Discharger shall monitor effluent discharged at Discharge Point No. 001 at Monitoring Location M-001 as follows.

**Table E-3. Major Constituents and Properties of Wastewater**

Parameter	Units	Sample Type	Minimum Sampling Frequency	Required Analytical Test Method
Average Daily Flow	MGD	Metered	1/Day	[1]
Maximum Daily Flow	MGD	Calculated	1/Month	[1]
Mean Daily Flow	MGD	Calculated	1/Month	[1]
Oil and Grease	mg/L	Grab	1/Week	[1]
Total Petroleum Hydrocarbons	mg/L	Grab	1/Week	[2]
pH	s.u.	Grab	1/Quarter	[1]
Settleable Solids	ml/L	Grab	1/Quarter	[1]
TSS	mg/L	Grab	1/Quarter	[1]
Turbidity	NTU	Grab	1/Quarter	[1]

[1] As required under 40 CFR Part 136.

[2] EPA Method 8015-Modified.

**Table E-4a. Effluent Monitoring, Ocean Plan Table B Pollutants – Protection of Marine Aquatic Life**

Parameter	Units	Sample Type	Minimum Sampling Frequency <sup>[1]</sup>	Required Analytical Test Method
Arsenic, Total Recoverable	µg/L	Grab	1/Year	[2]
Cadmium, Total Recoverable	µg/L	Grab	1/Year	[2]
Chromium (VI), Total Recoverable <sup>[3]</sup>	µg/L	Grab	1/Year	[2]
Copper, Total Recoverable	µg/L	Grab	1/Year	[2]
Lead, Total Recoverable	µg/L	Grab	1/Year	[2]
Mercury, Total Recoverable	µg/L	Grab	1/Year	[2]
Nickel, Total Recoverable	µg/L	Grab	1/Year	[2]
Selenium, Total	µg/L	Grab	1/Year	[2]

Parameter	Units	Sample Type	Minimum Sampling Frequency <sup>[1]</sup>	Required Analytical Test Method
Recoverable				
Silver, Total Recoverable	µg/L	Grab	1/Year	[2]
Zinc, Total Recoverable	µg/L	Grab	1/Year	[2]
Cyanide, Total Recoverable	µg/L	Grab	1/Year	[2]
Ammonia, Total (as N)	µg/L	Grab	1/Year	[2]
Chronic Toxicity <sup>[4]</sup>	TUc	Grab	1/Permit Term	[5]
Phenolic Compounds (non-chlorinated)	µg/L	Grab	1/Quarter	[2]
Chlorinated Phenolics	µg/L	Grab	1/Quarter	[2]
Endosulfan <sup>[6]</sup>	µg/L	Grab	1/Year	[2]
Endrin	µg/L	Grab	1/Year	[2]
HCH <sup>[7]</sup>	µg/L	Grab	1/Year	[2]

[1] Monitoring shall occur during dry weather conditions.

[2] As required under 40 CFR Part 136.

[3] The Discharger may, at their option meet the effluent limitation for chromium (VI) as total chromium limitations.

[4] If a discharge exceeds chronic toxicity effluent limitations, a toxicity identification evaluation (TIE) and a toxicity reduction evaluation (TRE) may be required at the request of the Executive Officer. The TIE/TRE shall include all reasonable steps to identify the sources of toxicity. Once the sources of toxicity are identified, the Discharger shall take all reasonable steps necessary to reduce toxicity to the required level. Refer to Monitoring and Reporting Program, section IV.

[5] As specified in section VI of this MRP.

[6] Shall mean the sum of endosulfan-alpha and -beta and endosulfan sulfate.

[7] Shall mean the sum of alpha, beta, gamma and delta isomers of hexachlorocyclohexane.

**Table E-4b. Effluent Monitoring, Ocean Plan Table B Pollutants – Protection of Human Health, Non-Carcinogens**

Parameter	Units	Sample Type	Minimum Sampling Frequency <sup>[1]</sup>	Required Analytical Test Method
Acrolein	µg/L	Grab	1/Permit Term	[2]
Antimony	µg/L	Grab	1/Permit Term	[2]
Bis(2-chloroethoxy)methane	µg/L	Grab	1/Permit Term	[2]
Bis(2-chloroisopropyl)ether	µg/L	Grab	1/Permit Term	[2]
Chlorobenzene	µg/L	Grab	1/Permit Term	[2]
Chromium (III)	µg/L	Grab	1/Permit Term	[2]
Di-n-butyl Phthalate	µg/L	Grab	1/Permit Term	[2]
Dichlorobenzenes <sup>[3]</sup>	µg/L	Grab	1/Permit Term	[2]
Diethyl Phthalate	µg/L	Grab	1/Permit Term	[2]
Dimethyl Phthalate	µg/L	Grab	1/Permit Term	[2]
4,6-Dinitro-2-Methylphenol	µg/L	Grab	1/Permit Term	[2]
2,4-Dinitrophenol	µg/L	Grab	1/Permit Term	[2]
Ethylbenzene	µg/L	Grab	1/Week	[2]
Fluoranthene	µg/L	Grab	1/Permit Term	[2]
Hexachlorocyclopentadiene	µg/L	Grab	1/Permit Term	[2]
Nitrobenzene	µg/L	Grab	1/Permit Term	[2]
Thallium	µg/L	Grab	1/Permit Term	[2]
Toluene	µg/L	Grab	1/Week	[2]

Parameter	Units	Sample Type	Minimum Sampling Frequency <sup>[1]</sup>	Required Analytical Test Method
Tributyltin	µg/L	Grab	1/Permit Term	[2]
1,1,1-Trichloroethane	µg/L	Grab	1/Permit Term	[2]

[1] Monitoring shall occur during dry weather conditions.

[2] As required by 40 CFR Part 136.

[3] Shall mean the sum of 1,2- and 1,3-dichlorobenzene.

**Table E-4c. Effluent Monitoring, Ocean Plan Table B Pollutants – Protection of Human Health, Carcinogens**

Parameter	Units	Sample Type	Minimum Sampling Frequency <sup>[1]</sup>	Required Analytical Test Method
Methyl Tertiary Butyl Ether	µg/L	Grab	1/Week	[2]
Total Xylenes	µg/L	Grab	1/Week	[2]
Acrylonitrile	µg/L	Grab	1/Permit Term	[2]
Aldrin	µg/L	Grab	1/Permit Term	[2]
Benzene	µg/L	Grab	1/Week	[2]
Benzidine	µg/L	Grab	1/Permit Term	[2]
Beryllium	µg/L	Grab	1/Permit Term	[2]
Bis(2-chloroethyl)ether	µg/L	Grab	1/Permit Term	[2]
Bis(2-ethylhexyl)phthalate	µg/L	Grab	1/Permit Term	[2]
Carbon Tetrachloride	µg/L	Grab	1/Permit Term	[2]
Chlordane	µg/L	Grab	1/Permit Term	[2]
Chlorodibromomethane	µg/L	Grab	1/Permit Term	[2]
Chloroform	µg/L	Grab	1/Permit Term	[2]
DDT <sup>[3]</sup>	µg/L	Grab	1/Permit Term	[2]
1,4-Dichlorobenzene	µg/L	Grab	1/Permit Term	[2]
3,3'-Dichlorobenzidine	µg/L	Grab	1/Permit Term	[2]
1,2-Dichloroethane	µg/L	Grab	1/Permit Term	[2]
1,1-Dichloroethylene	µg/L	Grab	1/Permit Term	[2]
Dichlorobromomethane	µg/L	Grab	1/Permit Term	[2]
Dichloromethane	µg/L	Grab	1/Permit Term	[2]
1,3-Dichloropropene	µg/L	Grab	1/Permit Term	[2]
Dieldrin	µg/L	Grab	1/Permit Term	[2]
2,4-Dinitrotoluene	µg/L	Grab	1/Permit Term	[2]
1,2-Diphenylhydrazine	µg/L	Grab	1/Permit Term	[2]
Halomethanes <sup>[4]</sup>	µg/L	Grab	1/Permit Term	[2]
Heptachlor	µg/L	Grab	1/Permit Term	[2]
Heptachlor Epoxide	µg/L	Grab	1/Permit Term	[2]
Hexachlorobenzene	µg/L	Grab	1/Permit Term	[2]
Hexachlorobutadiene	µg/L	Grab	1/Permit Term	[2]
Hexachloroethane	µg/L	Grab	1/Permit Term	[2]
Isophorone	µg/L	Grab	1/Permit Term	[2]
N-nitrosodimethylamine	µg/L	Grab	1/Permit Term	[2]
N-nitrosodi-N-propylamine	µg/L	Grab	1/Permit Term	[2]

Parameter	Units	Sample Type	Minimum Sampling Frequency <sup>[1]</sup>	Required Analytical Test Method
N-nitrosodiphenylamine	µg/L	Grab	1/Permit Term	[2]
PAHs <sup>[5]</sup>	µg/L	Grab	1/Week	[2]
PCBs <sup>[6]</sup>	µg/L	Grab	1/Permit Term	[2]
TCDD Equivalents <sup>[7]</sup>	µg/L	Grab	1/Permit Term	[2]
1,1,2,2-Tetrachloroethane	µg/L	Grab	1/Permit Term	[2]
Tetrachloroethylene	µg/L	Grab	1/Permit Term	[2]
Toxaphene	µg/L	Grab	1/Permit Term	[2]
Trichloroethylene	µg/L	Grab	1/Permit Term	[2]
1,1,2-Trichloroethane	µg/L	Grab	1/Permit Term	[2]
2,4,6-Trichlorophenol	µg/L	Grab	1/Permit Term	[2]
Vinyl Chloride	µg/L	Grab	1/Permit Term	[2]

[1] Monitoring shall occur during dry weather conditions.

[2] As required under 40 CFR Part 136.

[3] Shall mean the sum of 4,4'DDT; 2,4'DDT; 4,4'DDE; 2,4'DDE; 4,4'DDD; and 2,4'DDD.

[4] Shall mean the sum of bromoform, bromomethane and chloromethane.

[5] PAHs (polynuclear aromatic hydrocarbons) shall mean the sum of acenaphthylene; anthracene; 1,2-benzanthracene; 3,4-benzofluoranthene; benzo[k]fluoranthene; 1,12-benzoperylene; benzo[a]pyrene; chrysene; dibenzo[a,h]anthracene; fluorene; indeno[1,2,3-cd]pyrene; phenanthrene; and pyrene.

[6] PCBs (polychlorinated biphenyls) shall mean the sum of chlorinated biphenyls whose analytical characteristics resemble those of Aroclor-1016, Aroclor-1221, Aroclor-1232, Aroclor-1242, Aroclor-1248, Aroclor-1254, and Aroclor-1260.

[7] TCDD equivalents represent the sum of concentrations of chlorinated dibenzodioxins (2,3,7,8-CDDs) and chlorinated dibenzofurans (2,3,7,8-CDFs) multiplied by their respective toxicity factors, as shown by the table below. USEPA Method 8280 may be used to analyze TCDD equivalents.

Isomer Group	Toxicity Equivalence Factor
2,3,7,8 – tetra CDD	1.0
2,3,7,8 – penta CDD	0.5
2,3,7,8 – hexa CDD	0.1
2,3,7,8 – hepta CDD	0.01
octa CDD	0.001
2,3,7,8 – tetra CDF	0.1
1,2,3,7,8 – penta CDF	0.05
2,3,4,7,8 – penta CDF	0.5
2,3,7,8 – hexa CDFs	0.1
2,3,7,8 – hepta CDFs	0.01
Octa CDF	0.001

## V. Internal Monitoring Requirements

### A. Monitoring Locations M-INT-1 and M-INT-2

1. The Discharger shall monitor and analyze the internal process monitoring system at M-INT-1 and M-INT-2 as follows. Samples taken at M-INT-2 shall be analyzed as soon as possible (under a two-week turnaround time) to evaluate for potential treatment system breakthrough or for replacement of carbon media and rotation of GAC canisters.

**Table E-5. Internal Process Monitoring Constituents**

Parameter	Units	Sample Type	Minimum Sampling Frequency	Required Analytical Test Method
Oil and Grease	mg/L	Grab	1/Week	[1]



Parameter	Units	Sample Type	Minimum Sampling Frequency	Required Analytical Test Method
Total Petroleum Hydrocarbons	mg/L	Grab	1/Week	[2]
Benzene	µg/L	Grab	1/Week	[1]
Toluene	µg/L	Grab	1/Week	[1]
Ethylbenzene	µg/L	Grab	1/Week	[1]
Methyl Tertiary Butyl Ether	µg/L	Grab	1/Week	[1]
PAHs <sup>[3]</sup>	µg/L	Grab	1/Week	[1]

<sup>[1]</sup> As required under 40 CFR Part 136.

<sup>[2]</sup> EPA Method 8015-Modified

<sup>[3]</sup> PAHs (polynuclear aromatic hydrocarbons) shall mean the sum of acenaphthylene; anthracene; 1,2-benzanthracene; 3,4-benzofluoranthene; benzo[k]fluoranthene; 1,12-benzoperylene; benzo[a]pyrene; chrysene; dibenzo[a,h]anthracene; fluorene; indeno[1,2,3-cd]pyrene; phenanthrene; and pyrene.

## VI. Whole Effluent Toxicity Testing Requirements

### A. Whole Effluent Chronic Toxicity

The presence of chronic toxicity shall be estimated as specified in *Short Term Methods for Estimating the Chronic Toxicity of Effluents and Receiving Waters to West Coast Marine and Estuarine Organisms*, EPA-821/600/R-95/136; *Short Term Methods for Estimating Chronic Toxicity of Effluents and Receiving Waters to Marine and Estuarine Organisms*, EPA-600-4-91-003; *Procedures Manual for Conducting Toxicity Tests Developed by the Marine Bioassay Project*, SWRCB 9601WQ; and/or *Short Term Methods for Estimating the Chronic Toxicity of Effluents and Receiving Waters to Marine and Estuarine Organisms*, EPA/600/4-87-028 or subsequent editions.

Chronic toxicity measures a sublethal effect (e.g., reduced growth or reproduction) to experimental test organisms exposed to an effluent compared to that of the control organisms.

$$\text{Chronic Toxicity (TUc)} = 100/\text{NOEL}$$

The no observed effect level (NOEL) is the maximum tested concentration in a medium which does not cause known adverse effects upon chronic exposure in the species in question (i.e., the highest effluent concentration to which organisms are exposed in a chronic test that causes no observable adverse effects on the test organisms; e.g., the highest concentration of a toxicant to which the values for the observed responses are not statistically significantly different from the controls). Examples of chronic toxicity include, but are not limited to, measurements of toxicant effects on reproduction, growth, and sublethal effects that can include behavioral, physiological, and biochemical effects.

In accordance with the 2009 Ocean Plan, Appendix III, Standard Monitoring Procedures, the Discharger shall use the critical life stage toxicity tests specified in the table below to measure TUc. Other species or protocols will be added to the list after State Water Board review and approval.

A minimum of three test species with approved test protocols shall be used to measure compliance with the toxicity limitation. If possible, the test species shall include a fish, an invertebrate, and an aquatic plant. After a screening period of no fewer than three sampling events, monitoring can be reduced to the most sensitive species. The sensitivity of the test organisms to a reference toxicant shall be determined concurrently with each bioassay test and reported with the test results.

**Table E-6. Approved Tests – Chronic Toxicity**

Species	Test	Tier <sup>[1]</sup>	Reference <sup>[2]</sup>
Giant Kelp, <i>Macrocystis pyrifera</i>	percent germination; germ tube length	1	a,c
Red abalone, <i>Haliotis rufescens</i>	abnormal shell development	1	a,c
Oyster, <i>Crassostrea gigas</i> ; mussels, <i>Mytilus spp.</i>	abnormal shell development; percent survival	1	a,c
Urchin, <i>Strongylocentrotus purpuratus</i> ; sand dollar, <i>Dendraster excentricus</i>	percent normal development	1	a,c
Urchin, <i>Strongylocentrotus purpuratus</i> ; sand dollar, <i>Dendraster excentricus</i>	percent fertilization	1	a,c
Shrimp, <i>Homesimysis costata</i>	percent survival; growth	1	a,c
Shrimp, <i>Mysidopsis bahia</i>	percent survival; fecundity	2	d,d
Topsmelt, <i>Atherinops affinis</i>	larval growth rate; percent survival	1	a,c
Silverside, <i>Menidia beryllina</i>	larval growth rate; percent survival	2	b,d

[1] First tier methods are preferred for compliance monitoring. If first tier organisms are not available, the Discharger can use a second tier test method following approval from the Central Coast Water Board.

[2] Protocol References

- a. Chapman, G.A., D.L. Denton, and J.M. Lazorchak. 1995. *Short-term Methods for Estimating Chronic Toxicity of Effluents and Receiving Waters to West Coast Marine and Estuarine Organisms*. USEPA Report No. EPA/600/R-95/136.
- b. Klemm, D.J., G.E. Morrison, T.J. Norberg-King, W.J. Peltier, and M.A. Heber. 1994. *Short-term Methods for Estimating the Chronic Toxicity of Effluents and Receiving Water to Marine and Estuarine Organisms*. USEPA Report No. EPA-600-4-91-003.
- c. SWRCB 1996. *Procedures Manual for Conducting Toxicity Tests Developed by the Marine Bioassay Project*. 96-1WQ.
- d. Weber, C.I., W.B. Horning, II, D.J. Klemm, T.W. Nieheisel, P.A. Lewis, E.L. Robinson, J. Menkedick, and F. Kessler (eds). 1998. *Short-term Methods for Estimating the Chronic Toxicity of Effluents and Receiving Waters to Marine and Estuarine Organisms*. EPA/600/4-87/028. National Information Service, Springfield, VA.

Dilution and control waters shall be obtained from an area of the receiving waters, typically upstream, which is unaffected by the discharge. Standard dilution water can be used, if the receiving water itself exhibits toxicity or if approved by the Central Coast Water Board. If the dilution water used in testing is different from the water in which the test organisms were cultured, a second control sample using culture water shall be tested.

If the effluent to be discharged to a marine or estuarine system (e.g., salinity values in excess of 1,000 mg/L) originates from a freshwater supply, salinity of the effluent must be increased with dry ocean salts (e.g. FORTY FATHOMS®) to match salinity of the receiving water. This modified effluent shall then be tested using marine species.

If chronic toxicity is measured in the effluent above 16 TUc, the Discharger shall resample and submit the results to the Central Coast Water Board as described in section VI.C.2.a of this Order.

## **B. Toxicity Reporting**

1. The Discharger shall include a full report of toxicity test results with the regular monthly monitoring report and include the following information.
  - a. Toxicity test results;
  - b. Dates of sample collection and initiation of each toxicity test; and,
  - c. Chronic toxicity discharge limitations (or value).
2. Toxicity test results shall be reported according to the appropriate guidance - *Methods for Measuring the Acute Toxicity of Effluents and Receiving Waters to Freshwater and Marine Organisms*, Fifth Edition, USEPA Office of Water, EPA-821-R-02-012 (2002) or the latest edition, or *Short Term Methods for Estimating the Chronic Toxicity of Effluents and Receiving Waters to Freshwater and Marine Organisms*, EPA-821-R-02-012 (2002) or subsequent editions.
3. If the initial investigation TRE workplan is used to determine that additional (accelerated) toxicity testing is unnecessary, these results shall be submitted with the monitoring report for the month in which investigations conducted under the TRE workplan occurred.
4. Within 30 days of receipt of test results exceeding a chronic toxicity discharge limitation, the Discharger shall provide written notification to the Executive Officer of:
  - a. Findings of the TRE or other investigation to identify the cause(s) of toxicity; and
  - b. Actions the Discharger has taken/will take, to mitigate the impact of the discharge and to prevent the recurrence of toxicity.

When corrective actions, including a TRE, have not been completed, a schedule under which corrective actions will be implemented, or the reason for not taking corrective action, if no action has been taken.

**VII. Land Discharge Monitoring Requirements – Not Applicable**

**VIII. Reclamation Monitoring Requirements – Not Applicable**

**IX. Receiving Water Monitoring Requirements – Not Applicable**

**X. Other Monitoring Requirements**

**A. Ocean Outfall Inspection**

At least once per year (in the same month annually) the Discharger shall visually inspect the entire outfall and diffuser structure (e.g. divers, dye study) to note its structural integrity, excessive corrosion, and any cracks, breaks, leaks, plugged ports, or other actual or potential malfunctions. The outfall inspection will also check for possible external blockage of ports by sand and/or silt deposition. The Discharger shall report all findings and actions, including observed cracks, breaks, or malfunctions to the Executive Officer in the applicable annual report. The month for inspection specified by the Discharger shall be a month of good underwater visibility.

**XI. Reporting Requirements**

**A. General Monitoring and Reporting Requirements**

1. The Discharger shall comply with all Standard Provisions (Attachment D) related to monitoring, reporting, and recordkeeping.

**B. Self-Monitoring Reports (SMRs)**

1. The Discharger must electronically submit Self-Monitoring Reports (SMRs) using the State Water Board's California Integrated Water Quality System (CIWQS) Program Web site (<http://www.waterboards.ca.gov/ciwqs/index.html>). The CIWQS Web site will provide additional directions for SMR submittal in the event there will be service interruption for electronic submittal.
2. The Discharger shall report in the SMR the results for all monitoring specified in this MRP under sections III through X. The Discharger shall submit monthly, quarterly, semiannual, and annual SMRs including the results of all required monitoring using USEPA approved test methods or other test methods specified in this Order. If the Discharger monitors any pollutant more frequently than required by this Order, the results of this monitoring shall be included in the calculations and reporting of the data submitted in the SMR.
3. Monitoring periods and reporting for all required monitoring shall be completed according to the following schedule:

**Table E-7. Monitoring Periods and Reporting Schedule**

Sampling Frequency	Monitoring Period Begins On ...	Monitoring Period	SMR Due Date
Continuous	December 7, 2017	All	<u>First day of second calendar month following month of sampling</u>
1/Hour	December 7, 2017	Hourly	
1/Day	December 7, 2017	(Midnight through 11:59 PM) or any 24-hour period that reasonably represents a calendar day for purposes of sampling.	
1/Week	Sunday following permit effective date or on permit effective date if on a Sunday	Sunday through Saturday	
1/Month	First day of calendar month following permit effective date or on permit effective date if that date is first day of the month	1 <sup>st</sup> day of calendar month through last day of calendar month	
1/Quarter	Closest of January 1, April 1, July 1, or October 1 following (or on) permit effective date	January 1 through March 31 April 1 through June 30 July 1 through September 30 October 1 through December 31	April 30 July 30 October 30 January 30
2/Year	January 1 following (or on) permit effective date	January 1 through June 30 July 1 through December 31	August 1 January 30
1/Year	January 1 following (or on) permit effective date	January 1 through December 31	January 30
X/Permit Term	1 year prior to Order expiration date	Permit term	180 days prior to Order expiration date, submitted with Report of Waste Discharge.

**4. Reporting Protocols.** The Discharger shall report with each sample result the applicable reported Minimum Level (ML) and the current Method Detection Limit (MDL), as determined by the procedure in Part 136.

The Discharger shall report the results of analytical determinations for the presence of chemical constituents in a sample using the following reporting protocols:

- a. Sample results greater than or equal to the reported ML shall be reported as measured by the laboratory (i.e., the measured chemical concentration in the sample).
- b. Sample results less than the reported ML, but greater than or equal to the laboratory’s MDL, shall be reported as “Detected, but Not Quantified,” or DNQ. The estimated chemical concentration of the sample shall also be reported.

For the purposes of data collection, the laboratory shall write the estimated chemical concentration next to DNQ as well as the words “Estimated Concentration” (may be shortened to “Est. Conc.”). The laboratory may, if such information is available, include numerical estimates of the data quality for the reported result. Numerical estimates of data quality may be percent accuracy ( $\pm$

- a percentage of the reported value), numerical ranges (low to high), or any other means considered appropriate by the laboratory.
- c.** Sample results less than the laboratory's MDL shall be reported as "Not Detected," or ND.
  - d.** Dischargers are to instruct laboratories to establish calibration standards so that the ML value (or its equivalent if there is differential treatment of samples relative to calibration standards) is the lowest calibration standard. At no time is the Discharger to use analytical data derived from extrapolation beyond the lowest point of the calibration curve.
- 5.** Compliance Determination. Compliance with effluent limitations for priority pollutants shall be determined using sample reporting protocols defined above and Attachment A of this Order. For purposes of reporting and administrative enforcement by the Central Coast and State Water Boards, the Discharger shall be deemed out of compliance with effluent limitations if the concentration of the priority pollutant in the monitoring sample is greater than the effluent limitation and greater than or equal to the reporting level (RL).
- 6.** Multiple Sample Data. When determining compliance with an AMEL, AWEL, or MDEL for priority pollutants and more than one sample result is available, the Discharger shall compute the arithmetic mean unless the data set contains one or more reported determinations of "Detected, but Not Quantified" (DNQ) or "Not Detected" (ND). In those cases, the Discharger shall compute the median in place of the arithmetic mean in accordance with the following procedure:
- a.** The data set shall be ranked from low to high, ranking the reported ND determinations lowest, DNQ determinations next, followed by quantified values (if any). The order of the individual ND or DNQ determinations is unimportant.
  - b.** The median value of the data set shall be determined. If the data set has an odd number of data points, then the median is the middle value. If the data set has an even number of data points, then the median is the average of the two values around the middle unless one or both of the points are ND or DNQ, in which case the median value shall be the lower of the two data points where DNQ is lower than a value and ND is lower than DNQ.
- 7.** The Discharger shall submit SMRs in accordance with the following requirements:
- a.** The Discharger shall arrange all reported data in a tabular format. The data shall be summarized to clearly illustrate whether the facility is operating in compliance with interim and/or final effluent limitations. The Discharger is not required to duplicate the submittal of data that is entered in a tabular format within CIWQS. When electronic submittal of data is required and CIWQS does not provide for entry into a tabular format within the system, the Discharger shall electronically submit the data in a tabular format as an attachment.

- b. The Discharger shall attach a cover letter to the SMR. The information contained in the cover letter shall clearly identify violations of the WDRs; discuss corrective actions taken or planned; and the proposed time schedule for corrective actions. Identified violations must include a description of the requirement that was violated and a description of the violation.
- c. SMRs must be submitted to the Central Coast Water Board, signed and certified as required by the Standard Provisions (Attachment D), to the electronic mail address listed below:

California Regional Water Quality Board  
 Central Coast Region  
[centralcoast@wateboards.ca.gov](mailto:centralcoast@wateboards.ca.gov)  
 895 Aerovista Place, Suite 101  
 San Luis Obispo, California 93401

**C. Discharge Monitoring Reports (DMRs)**

- 1. DMRs must be signed and certified as required by the standard provisions (Attachment D). The Discharger shall submit the original DMR and one copy of the DMR to the address listed below:

STANDARD MAIL	FEDEX/UPS/ OTHER PRIVATE CARRIERS
State Water Resources Control Board Division of Water Quality c/o DMR Processing Center PO Box 100 Sacramento, CA 95812-1000	State Water Resources Control Board Division of Water Quality c/o DMR Processing Center 1001 I Street, 15 <sup>th</sup> Floor Sacramento, CA 95814

- 2. All discharge monitoring results must be reported on the official USEPA pre-printed DMR forms (EPA Form 3320-1). Forms that are self-generated will not be accepted unless they follow the exact same format of EPA Form 3320-1.

**D. Other Reports**

- 1. The Discharger shall report the results of any special monitoring, TREs, or other data or information that results from the Special Provisions, section VI.C, of the Order. The Discharger shall submit such reports with the first monthly SMR scheduled to be submitted on or immediately following the report due date.

# ATTACHMENT F – FACT SHEET

## Table of Contents

Attachment F – Fact Sheet .....	3
I. Permit Information .....	3
II. Facility Description .....	4
A. Description of Wastewater .....	5
B. Discharge Points and Receiving Waters .....	5
C. Summary of Existing Requirements and Effluent Characterization .....	6
D. Compliance Summary .....	9
E. Planned Changes .....	9
III. Applicable Plans, Policies, and Regulations .....	9
A. Legal Authorities .....	10
B. California Environmental Quality Act (CEQA) .....	10
C. State and Federal Regulations, Policies, and Plans .....	10
D. Impaired Water Bodies on CWA 303(d) List .....	12
E. Other Plans, Policies and Regulations – Not Applicable .....	12
IV. Rationale For Effluent Limitations and Discharge Specifications .....	12
A. Discharge Prohibitions .....	13
B. Technology-Based Effluent Limitations .....	13
1. Scope and Authority .....	13
2. Applicable Technology-Based Effluent Limitations .....	14
C. Water Quality-Based Effluent Limitations (WQBELs) .....	14
1. Scope and Authority .....	14
2. Applicable Beneficial Uses and Water Quality Criteria and Objectives .....	15
3. Determining the Need for WQBELs .....	15
4. WQBEL Calculations .....	21
5. Whole Effluent Toxicity (WET) .....	24
D. Final Effluent Limitations .....	25
1. Satisfaction of Anti-Backsliding Requirements .....	25
2. Satisfaction of Antidegradation Policy .....	26
3. Stringency of Requirements for Individual Pollutants .....	26
4. Summary of Final Effluent Limitations – Discharge Point No. 001 .....	26
E. Interim Effluent Limitations – Not Applicable .....	27
F. Land Discharge Effluent Limitations and Specifications – Not Applicable .....	27
G. Reclamation Specifications – Not Applicable .....	27
V. Rationale for Receiving Water Limitations .....	27
A. Surface Water .....	27
B. Groundwater – Not Applicable .....	27
VI. Rationale for Monitoring and Reporting Requirements .....	27
A. Influent Monitoring Requirements .....	27
B. Effluent Monitoring Requirements .....	27
C. Internal Monitoring Requirements .....	28
D. Whole Effluent Toxicity Testing Requirements .....	28
E. Land Discharge Monitoring Requirements – Not Applicable .....	28
F. Reclamation Monitoring Requirements – Not Applicable .....	28
G. Receiving Water Monitoring Requirements – Not Applicable .....	28
H. Other Monitoring Requirements .....	28



VII. Rationale for Provisions..... 29

    A. Standard Provisions..... 29

    B. Monitoring and Reporting Program (MRP) Requirements ..... 29

    C. Special Provisions..... 29

        1. Reopener Provisions..... 29

        2. Special Studies and Additional Monitoring Requirements..... 29

        3. Best Management Practices and Pollution Prevention ..... 30

        4. Construction, Operation, and Maintenance Specifications – Not Applicable..... 30

        5. Special Provisions for Municipal Facilities (POTWs Only) – Not Applicable ..... 30

        6. Other Special Provisions..... 30

        7. Compliance Schedules – Not Applicable ..... 31

VIII. Public Participation ..... 31

    A. Notification of Interested Parties ..... 31

    B. Written Comments ..... 31

    C. Public Hearing ..... 32

    D. Waste Discharge Requirements Petitions..... 32

    E. Information and Copying..... 32

    F. Register of Interested Persons ..... 33

    G. Additional Information ..... 33

**List of Tables**

Table F-1. Facility Information ..... 3

Table F-2. Historic Effluent Limitations and Monitoring Data, Major Constituents and Properties of Wastewater, Discharge Point No. 001..... 6

Table F-3. Historic Effluent Limitations and Monitoring Data, Protection of Marine Aquatic Life, Discharge Point No. 001 ..... 6

Table F-4. Historic Effluent Limitations and Monitoring Data, Protection of Human Health – Non-Carcinogens, Discharge Point No. 001..... 7

Table F-5. Historic Effluent Limitations and Monitoring Data, Protection of Human Health – Carcinogens, Discharge Point No. 001 ..... 8

Table F-6. Basin Plan Beneficial Uses..... 10

Table F-7. Ocean Plan Beneficial Uses..... 11

Table F-8. Effluent Limitations Based on Table A of the Ocean Plan ..... 14

Table F-9. RPA Results ..... 18

Table F-10. Pollutants Having Background Concentrations ..... 21

Table F-11a. Effluent Limitations, Protection of Marine Aquatic Life ..... 21

Table F-11b. Effluent Limitations, Protection of Human Health – Non-Carcinogens ..... 22

Table F-11c. Effluent Limitations, Protection of Human Health – Carcinogens ..... 23

**Attachment F – Fact Sheet**

As described in section II of the Order, this Fact Sheet includes the legal requirements and technical rationale that serve as the basis for the requirements of this Order.

This Order has been prepared under a standardized format to accommodate a broad range of discharge requirements for dischargers in California. Only those sections or subsections of this Order that are specifically identified as “not applicable” have been determined not to apply to this Discharger. Sections or subsections of this Order not specifically identified as “not applicable” are fully applicable to this Discharger.

**I. Permit Information**

The following table summarizes administrative information related to the Facility.

**Table F-1. Facility Information**

<b>WDID</b>	3 402005001
<b>Discharger</b>	Chevron Environmental Management Company (CEMC)
<b>Name of Facility</b>	Chevron Estero Marine Terminal
<b>Facility Address</b>	4000 Highway One
	Morro Bay, CA 93442
	San Luis Obispo County
<b>Facility Contact, Title and Phone</b>	Andy Smith, Project Manager, (805) 546-6915
<b>Authorized Person to Sign and Submit Reports</b>	Randy Jewett, CEMC Environmental Compliance Officer
<b>Mailing Address</b>	4000 Highway One, Morro Bay, CA 93442
<b>Billing Address</b>	SAME
<b>Type of Facility</b>	Former Oil Tanker Loading Terminal
<b>Major or Minor Facility</b>	Minor
<b>Threat to Water Quality</b>	2
<b>Complexity</b>	B
<b>Pretreatment Program</b>	No
<b>Reclamation Requirements</b>	No
<b>Facility Permitted Flow</b>	0.21 million gallons per day (MGD)
<b>Facility Design Flow</b>	0.21 MGD
<b>Watershed</b>	Estero Bay Hydrologic Unit
<b>Receiving Waters</b>	Pacific Ocean
<b>Receiving Water Type</b>	Saltwater and Freshwater

- A.** The Chevron Environmental Management Company (hereinafter Discharger) is the owner and operator of the Chevron Estero Marine Terminal (hereinafter Facility), a former oil tanker loading terminal and temporary storage facility that is currently being decommissioned.

For the purposes of this Order, references to the “Discharger” or “Permittee” in applicable federal and state laws, regulations, plans, or policy are held to be equivalent to references to the Discharger herein.

- B.** The Facility discharges treated wastewater to the Pacific Ocean at Estero Bay, a water of the United States, and is currently regulated by Order No. R3-2011-0219 and NPDES Permit No. CA0001465, which was adopted on December 1, 2011, and expires on January 13, 2017. The terms and conditions of the current Order will be automatically continued and remain in effect until new Waste Discharge Requirements (WDRs) and a National Pollutant Discharge Elimination System (NPDES) permit are adopted pursuant to this Order.
- C.** The Discharger filed a Report of Waste Discharge (ROWD) and submitted an application for renewal of its WDRs and NPDES permit on August 1, 2016.

## **II. Facility Description**

The Chevron Estero Marine Terminal was originally constructed in 1929 for the temporary storage and loading of crude oil from Chevron's Kern County oil fields as well as light crude oil and natural gas from Kettleman Hills oil fields. In the 1950s the Facility received and handled crude oil from Mobil's San Ardo oil field under a terminaling agreement. In 1999 the Facility was idled due to the completion of the Pacific Pipeline, which now transfers crude oil to the Los Angeles Basin refineries. The Facility is currently in the process of being decommissioned.

The Facility consists of approximately 3,200 acres. Of the 3,200 acres, approximately 25 acres were developed as part of the "Shore Plant" and approximately 235 acres were developed as part of the "Hill Plant." The Shore Plant included the control area for the marine terminal, housed the valve areas, and stored tanker ballast water. The Hill Plant consisted of 16 aboveground storage tanks. The majority of the tankage and pipelines within the Shore Plant and Hill Plant have been removed.

Recent demolition projects completed have removed the following on-site facilities: aboveground storage tanks and piping, removal of Shore Plant underground piping, and removal of several buildings and structures at the Shore Plant area. The Discharger has also completed partial abandonment of the offshore terminal including removal of moorings, chains, anchors, and other items.

Between 2009 and 2011, Chevron Environmental Management Company (CEMC) completed remedial excavations at three areas including the Cutter Stock area, 1999 Pipeline Release area, and Control House area. In 2011 the former ballast ponds were closed. New groundwater monitoring wells were installed at the excavation and backfill sites.

The Discharger anticipates performing the following decommissioning projects, which will be regulated by this Order for the treatment and discharge of wastewater.

- **Offshore Terminal Decommissioning Project.** The Discharger holds a state lands lease with the California State Lands Commission (CSLC) for the decommissioning of offshore terminal facilities following idling of the marine terminal. The Discharger is proposing the removal or decommissioning in-place of two offshore loading pipelines (LL1 and LL2) and the 16-inch diameter wastewater outfall line. The Discharger plans to complete this in the next five years.

## A. Description of Wastewater

The Discharger proposes to use a temporary wastewater treatment system located at the Shore Plant area to treat wastewater to be generated during the planned decommissioning and remediation projects at the site. The Discharger anticipates the following wastewater sources during decommissioning and remediation projects:

- Offshore loading line flush water conducted prior to removal of loading lines;
- Equipment cleaning;
- Groundwater from regular groundwater monitoring at Shore Plant;
- Groundwater extracted during remedial excavation activities; and
- Onshore pipeline hydro-static test and flush water.

The temporary treatment system will consist of a minimum of two 21,000-gallon capacity portable storage tanks, a 55-gallon vapor phase granular activated carbon (GAC) canister, an oil/water separator where separate petroleum will be decanted and transferred to a 500-gallon poly tank, two bag filters in parallel to remove sediment, one 1,000-pound clay media filter and two 2,000-pound liquid GAC canisters connected in series, and a 21,000-gallon treated water tank. The design average daily flow rate is 0.21 MGD.

As identified by the Discharger in the ROWD, the primary pollutants of concern at the Facility include total petroleum hydrocarbons (TPH) in the carbon range of C4 to C40, benzene, toluene, ethylbenzene, total xylenes, methyl tertiary-butyl ether (MTBE), and polycyclic aromatic hydrocarbons (PAHs). More frequent monitoring will be required for these pollutants than other pollutants, as described in the Monitoring and Reporting Program, Attachment E.

## B. Discharge Points and Receiving Waters

Treated wastewater will be discharged into the Pacific Ocean at Estero Bay through an approximately 3,000-foot outfall/diffuser system, at a depth of approximately 50 feet, at Discharge Point No. 001. Discharge Point No. 001 to the Pacific Ocean is located at 35° 24' 25" N Latitude; 120° 53' 05" W Longitude. The minimum initial dilution ratio of seawater to effluent is 15:1 (seawater: effluent).

Additionally, storm water is discharged from several oversized storm water detention basins to Toro Creek and the Pacific Ocean through Discharge Point Nos. 002-005. The Central Coast Water Board has determined that discharges from the Facility are applicable for coverage under the State Water Resources Control Board's (State Water Board) Water Quality Order 2014-0057-DWQ, NPDES General Permit No. CAS000001, as described in section VII.C.6.a of this Fact Sheet. The Discharger must obtain coverage under the storm water General Permit for discharges of storm water from the Facility. This Order does not directly regulate the discharge of storm water from the Facility.

### C. Summary of Existing Requirements and Effluent Characterization

Effluent limitations contained in the existing Order for discharges from Discharge Point No. 001 and representative monitoring data for Monitoring Location M-001, for the term of the previous Order, are presented in the following tables. The Discharger has not discharged since December 2010.

**Table F-2. Historic Effluent Limitations and Monitoring Data, Major Constituents and Properties of Wastewater, Discharge Point No. 001**

Parameter	Units	Effluent Limitation			Monitoring Data (May 2010 through December 2010)		
		Average Monthly	Average Weekly	Maximum Daily	Highest Average Monthly	Highest Average Weekly Discharge	Highest Daily Discharge
Oil and Grease	mg/L	25	40	75	6.0	6.0	6.0
Settleable Solids	ml/L	1.0	1.5	3.0	ND	ND	ND
pH	s.u.	6.0 – 9.0			8.6 <sup>[1]</sup>		
Turbidity	NTU	75	100	225	NA	NA	NA

NA = Not Available

ND = Not Detected

<sup>[1]</sup> Only two samples reported for pH, (May 5, 2010 and November 5, 2010), both of which were reported as 8.6 s.u.

**Table F-3. Historic Effluent Limitations and Monitoring Data, Protection of Marine Aquatic Life, Discharge Point No. 001**

Parameter	Units	Effluent Limitations			Highest Daily Discharge
		6-Month Median <sup>[1]</sup>	Daily Maximum <sup>[2]</sup>	Instantaneous Maximum <sup>[3]</sup>	
Arsenic	mg/L	0.08	0.47	1.2	0.0068
Cadmium	mg/L	0.02	0.06	0.16	0.00003
Chromium (VI) <sup>[4]</sup>	mg/L	0.03	0.13	0.32	0.00034 <sup>[5]</sup>
Copper	mg/L	0.02	0.16	0.45	0.0061
Lead	mg/L	0.03	0.13	0.32	0.00041
Mercury	µg/L	0.63	2.6	6.4	0.001
Nickel	mg/L	0.08	0.32	0.80	0.001
Selenium	mg/L	0.24	0.96	2.4	0.0013
Silver	mg/L	0.01	0.04	0.11	ND
Zinc	mg/L	0.20	1.2	3.1	0.022
Cyanide <sup>[6]</sup>	mg/L	0.02	0.06	0.16	ND
Total Chlorine Residual <sup>[7]</sup>	mg/L	0.03	0.13	0.96	NA
Ammonia (as N)	mg/L	9.6	38.0	96.0	1.6
Phenolic Compounds (non-chlorinated)	mg/L	0.48	1.9	4.8	0.005
Chronic Toxicity	TUc	--	16.0	--	NA
Chlorinated Phenolics	mg/L	0.02	0.06	0.16	ND

Parameter	Units	Effluent Limitations			Highest Daily Discharge
		6-Month Median <sup>[1]</sup>	Daily Maximum <sup>[2]</sup>	Instantaneous Maximum <sup>[3]</sup>	
Endosulfan	µg/L	0.14	0.29	0.43	ND
Endrin	µg/L	0.03	0.06	0.10	ND
HCH	µg/L	0.06	0.13	0.19	NA
Radioactivity	[8]				

NA = Not Applicable

ND = Not Detected and no MDL reported.

[1] The six-month median shall apply as a moving median of daily values for any 180-day period in which daily values represent flow weighted average concentrations within a 24-hour period. For intermittent discharges, the daily value shall be considered equal to zero for days in which no discharge occurred. The six-month median limit on daily mass emissions shall be determined using the six-month median effluent concentration  $C_e$  and the observed flow rate,  $Q$ , in million gallons per day (MGD).

[2] The daily maximum shall apply to flow weighted 24-hour composite samples. The daily maximum mass emission shall be determined using the daily maximum effluent concentration limit as  $C_e$  and the observed flow rate,  $Q$ , in MGD.

[3] The instantaneous maximum shall apply to grab sample determinations.

[4] The Discharger may, at their option, meet this limitation as a total chromium limitation.

[5] Reported as total chromium.

[6] If the Discharger can demonstrate to the satisfaction of the Central Coast Water Board that an analytical method is available to reliably distinguish between strongly and weakly complexed cyanide, effluent limitations for cyanide may be met by the combined measurement of free cyanide, simple alkali metals, and weakly complexed organometallic cyanide complexes. In order for the analytical method to be acceptable, the recovery of free cyanide from metal complexes must be comparable to that achieved by the approved method in 40 CFR 136, as revised July 1, 2003, or later.

[7] Water quality objectives for total chlorine residual applying to intermittent discharges not exceeding two hours shall be determined using the following equation:

$$\log(y) = -0.43 (\log x) + 1.8$$

where:  $y$  = the water quality objective (in µg/L) to apply when chlorine is being discharged

$x$  = the duration of uninterrupted chlorine discharges in minutes

The applicable effluent limitation must then be determined using Equation No. 1 from the Ocean Plan.

[8] Radioactivity is not to exceed limits specified in Title 17, Division 1, Chapter 5, Subchapter 4, Group 3, Article 3, Section 30253 of the California Code of Regulations. Reference to Section 30253 is prospective including future changes to incorporate provisions of federal law, as the changes take effect.

**Table F-4. Historic Effluent Limitations and Monitoring Data, Protection of Human Health – Non-Carcinogens, Discharge Point No. 001**

Parameter	Units	Effluent Limitation	Highest Reported Value
		30-day Average	
Acrolein	mg/L	3.5	ND
Antimony	mg/L	19.0	0.00055
Bis(2-Chloroethoxy)Methane	mg/L	0.07	ND
Bis(2-Chloroisopropyl)Ether	mg/l	19.0	ND
Chlorobenzene	mg/L	9.1	ND
Chromium (III)	g/L	3.0	3.4E-07
Di-n-butyl Phthalate	mg/L	56.0	ND
Dichlorobenzenes	mg/L	82.0	ND
1,1-Dichloroethylene	mg/L	110.0	ND

Parameter	Units	Effluent Limitation	Highest Reported Value
		30-day Average	
Diethyl Phthalate	g/L	530.0	ND
Dimethyl Phthalate	mg/L	13.0	ND
4,6-Dinitro-2-Methylphenol	mg/L	3.5	ND
2,4-Dinitrophenol	mg/L	0.06	ND
Ethylbenzene	mg/L	65.0	0.0008
Fluoranthene	mg/L	0.24	ND
Hexachlorocyclopentadiene	g/L	0.93	ND
Isophorone	mg/L	2.4	ND
Nitrobenzene	mg/L	0.08	ND
Thallium	g/L	0.22	ND
Toluene	mg/L	1.4	ND
1,1,2,2-Tetrachloroethane	mg/L	19.0	ND
Tributyltin	g/L	0.02	ND
1,1,1-Trichloroethane	mg/L	8.6	ND
1,1,2-Trichloroethane	mg/L	690.0	ND

ND = Not Detected

**Table F-5. Historic Effluent Limitations and Monitoring Data, Protection of Human Health – Carcinogens, Discharge Point No. 001**

Parameter	Units	Effluent Limitation	Highest Reported Value
		30-day Average	
Acrylonitrile	µg/L	1.6	ND
Aldrin	ng/L	0.35	ND
Benzene	µg/L	94.0	ND
Benzidine	µg/L	0.001	ND
Beryllium	µg/L	0.53	ND
Bis(2-Chloroethyl)Ether	µg/L	0.72	ND
Bis(2-Ethylhexyl)Phthalate	µg/L	56.0	ND
Carbon Tetrachloride	µg/L	14.0	ND
Chlordane <sup>[1]</sup>	ng/L	0.37	ND
Chloroform	µg/L	2,100	ND
DDT <sup>[2]</sup>	ng/L	2.7	ND
1,4-Dichlorobenzene	µg/L	290	ND
3,3'-Dichlorobenzidine	µg/L	0.13	ND
1,2-Dichloroethane	mg/L	2.1	ND
Dichloromethane	mg/L	7.2	NA
1,3-Dichloropropene	mg/L	0.14	NA
Dieldrin	ng/L	0.64	ND
2,4-Dinitrotoluene	µg/L	42.0	ND
1,2-Diphenylhydrazine	µg/L	2.6	ND
Halomethanes <sup>[3]</sup>	mg/L	2.1	NA
Heptachlor <sup>[4]</sup>	µg/L	0.01	ND
Hexachlorobenzene	ng/L	3.4	ND

Parameter	Units	Effluent Limitation	Highest Reported Value
		30-day Average	
Hexachlorobutadiene	µg/L	220.0	ND
Hexachloroethane	µg/L	40.0	ND
N-Nitrosodimethylamine	mg/L	0.12	ND
N-Nitrosodiphenylamine	µg/L	40.0	ND
PAHs <sup>[5]</sup>	µg/L	0.14	ND
PCBs <sup>[6]</sup>	ng/L	0.30	ND
TCDD Equivalents <sup>[7]</sup>	pg/L	0.06	ND
Tetrachloroethylene	mg/L	1.6	ND
Toxaphene	ng/L	3.4	ND
Trichloroethylene	µg/L	430.0	ND
2,4,6-Trichlorophenol	µg/L	4.6	ND
Vinyl Chloride	µg/L	580.0	ND

NA = Not Available

ND = Not Detected

<sup>[1]</sup> Chlordane shall mean the sum of chlordane-alpha, chlordane-gamma, chlordene-alpha, chlordene-gamma, nonachlor-alpha, nonachlor-gamma, and oxychlordane.

<sup>[2]</sup> DDT shall mean the sum of 4,4'-DDT; 2,4'-DDT; 4,4'-DDE; 4,4'-DDD; and 2,4'-DDD.

<sup>[3]</sup> Halomethanes shall mean the sum of bromoform, bromomethane (methyl bromide), chloromethane (methyl chloride), chlorodibromomethane, and dichlorobromomethane.

<sup>[4]</sup> Heptachlor shall mean the sum of heptachlor and heptachlor epoxide.

<sup>[5]</sup> PAHS (Polynuclear aromatic hydrocarbons) shall mean the sum of acenaphthylene, anthracene, 1,2-benzanthracene; 3,4-benzofluoranthene; benzo(k)fluoranthene; 1,12-benzoperylene; benzo(a)pyrene; chrysene; dibenzo(a,h)anthracene; fluorene; indeno(1,2,3-cd)pyrene; phenanthrene; and pyrene.

<sup>[6]</sup> PCBs (polychlorinated biphenyls) shall mean the sum of chlorinated biphenyls whose analytical characteristics resemble those of Aroclor-1016, Aroclor-1221, Aroclor-1232, Aroclor-1242, Aroclor-1248, Aroclor-1254, and Aroclor-1260.

<sup>[7]</sup> TCDD Equivalents shall mean the sum of those concentrations of chlorinated dibenzodioxins (2,3,7,8-CDDs) and chlorinated dibenzofurans (2,3,7,8-CDFs) multiplied by their respective toxicity factors, as listed in Appendix I of the Ocean Plan.

## D. Compliance Summary

The Discharger has been in compliance with all limitations and requirements of Order No. R3-2011-0219.

## E. Planned Changes

Presently, the Discharger is decommissioning the Facility and is proposing a temporary treatment system for the discharges associated with this cleanup. After decommissioning and cleanup of the Facility is complete, the Discharger plans to cease discharges and remove the temporary treatment system.

## III. Applicable Plans, Policies, and Regulations

The requirements contained in the proposed Order are based on the requirements and authorities described in this section.



**A. Legal Authorities**

This Order is issued pursuant to the federal Clean Water Act (CWA) §402 and implementing regulations adopted by the USEPA and California Water Code (CWC) chapter 5.5, division 7, commencing with §13370. It shall serve as an NPDES permit for point source discharges from this facility to surface waters. This Order also serves as waste discharge requirements (WDRs) pursuant to CWC article 4, chapter 4, division 7, commencing with §13260.

**B. California Environmental Quality Act (CEQA)**

Pursuant to CWC §13389, this action to adopt an NPDES permit is exempt from the provisions of CEQA, Public Resources Code §21100 through §21177.

**C. State and Federal Regulations, Policies, and Plans**

**1. Water Quality Control Plans.** The Central Coast Water Board has adopted a Water Quality Control Plan for the Central Coastal Region (hereinafter Basin Plan) that designates beneficial uses, establishes water quality objectives (WQOs), and contains implementation programs and policies to achieve those objectives for receiving waters addressed within the Region. To address ocean waters, the Basin Plan incorporates by reference the Water Quality Control Plan for Ocean Waters of California (the Ocean Plan). The Ocean Plan is discussed in further detail in section III.C.2 of this Fact Sheet.

The Basin Plan implements State Water Board Resolution No. 88-63, which establishes State policy that all waters, with certain exceptions, should be considered suitable or potentially suitable for municipal or domestic supply (MUN). Because of very high levels of total dissolved solids (TDS) in the Pacific Ocean, the receiving waters for discharges from the Facility meet an exception to Resolution No. 88-63, which precludes waters with TDS levels greater than 3,000 mg/L from the MUN designation. Beneficial uses established by the Basin Plan for the Pacific Ocean at Estero Bay are presented below.

**Table F-6. Basin Plan Beneficial Uses**

Discharge Point	Receiving Water	Beneficial Use(s)
001	Pacific Ocean at Estero Bay	Water Contact Recreation (REC-1) Non-contact Water Recreation (REC-2) Industrial Service Supply (IND) Navigation (NAV) Marine Habitat (MAR) Shellfish Harvesting (SHELL) Commercial and Sport Fishing (COMM) Rare, threatened, or endangered species (RARE) Wildlife Habitat (WILD)

Requirements of this Order implement the Basin Plan.

**2. California Ocean Plan.** The State Water Board adopted the Water Quality Control Plan for the Ocean Waters of California, California Ocean Plan (Ocean Plan) in 1972 and amended it in 1978, 1983, 1988, 1990, 1997, 2000, 2005, and 2009. The State Water Board adopted the latest amendment on September 15, 2009; it was approved by the Office of Administrative Law (OAL) on March 10, 2010 and subsequently approved by the USEPA. The Ocean Plan applies, in its entirety, to point source discharges to the Pacific Ocean. The Ocean Plan identifies the following beneficial uses of State ocean waters.

**Table F-7. Ocean Plan Beneficial Uses**

Discharge Point	Receiving Water	Beneficial Use(s)
001	Pacific Ocean at Estero Bay	Industrial Service Supply Water Contact and Non-Contact Recreation, including aesthetic enjoyment Navigation Commercial and Sport Fishing Mariculture Preservation and Enhancement of Designated Areas of Special Biological Significance (ASBS) Rare and Endangered Species Marine Habitat Fish Migration Fish Spawning and Shellfish Harvesting

- 3. Thermal Plan.** The State Water Board adopted a Water Quality Control Plan for Control Temperature in the Coastal and Interstate Water and Enclosed Bays and Estuaries of California (Thermal Plan) on May 18, 1972, and amended this plan on September 18, 1975. This plan contains temperature objectives for coastal waters of California.
- 4. Alaska Rule.** On March 30, 2000, USEPA revised its regulation that specifies when new and revised state and tribal water quality standards become effective for CWA purposes [65 Fed. Reg. 24641 (April 27, 2000), codified at 40 CFR 131.21]. Under the revised regulation (also known as the Alaska Rule), new and revised standards submitted to USEPA after May 30, 2000 must be approved by USEPA before being used for CWA purposes. The final rule also provides that standards already in effect and submitted to USEPA by May 30, 2000, may be used for CWA purposes, whether or not approved by USEPA.
- 5. Antidegradation Policy.** NPDES regulations at 40 CFR 131.12 require that State water quality standards include an antidegradation policy consistent with the federal policy. The State Water Board established California’s antidegradation policy in State Water Board Resolution No. 68-16, which incorporates the federal antidegradation policy where the federal policy applies under federal law. Resolution No. 68-16 requires that the existing quality of waters be maintained unless degradation is justified based on specific findings. The Central Coast Water Board’s Basin Plan implements and incorporates by reference both the State and federal antidegradation policies. As discussed in section IV.D.2 of this Fact Sheet, the

permitted discharge is consistent with the antidegradation provisions of 40 CFR 131.12 and State Water Board Resolution No. 68-16.

- 6. Anti-Backsliding Requirements.** CWA §402(o)(2) and §303(d)(4) and NPDES regulations at 40 CFR 122.44(l) prohibit backsliding in NPDES permits. These anti-backsliding provisions require effluent limitations in a reissued permit to be as stringent as those in the previous permit, with some exceptions where limitations may be relaxed. As discussed in section IV.D.1 of this Fact Sheet, effluent limitations and other requirements established by this Order satisfy applicable anti-backsliding provisions of the CWA and NPDES regulations.

#### **D. Impaired Water Bodies on CWA §303(d) List**

CWA §303(d) requires states to identify specific water bodies where water quality standards are not expected to be met after implementation of technology-based effluent limitations on point sources. For all §303(d) listed water bodies and pollutants, the Central Coast Water Board must develop and implement Total Maximum Daily Loads (TMDLs) that will specify Waste Load Allocations (WLAs) for point sources and Load Allocations (LAs) for non-point sources.

The USEPA approved the State's 2010 §303(d) list of impaired water bodies on November 12, 2010. The 2010 303(d) list does not include the Pacific Ocean at Estero Bay on the list.

TMDLs establish WLAs for point source and LAs for non-point sources and are intended to achieve the water quality standards for the impaired waterbodies. Currently, there are no TMDLs applicable to this Facility.

#### **E. Other Plans, Policies and Regulations – Not Applicable**

### **IV. Rationale For Effluent Limitations and Discharge Specifications**

The CWA requires point source dischargers to control the amount of conventional, non-conventional, and toxic pollutants that are discharged into the waters of the United States. The control of pollutants discharged is established through effluent limitations and other requirements in NPDES permits. NPDES regulations establish two principal bases for effluent limitations. At 40 CFR 122.44(a) permits are required to include applicable technology-based limitations and standards; and at 40 CFR 122.44(d) permits are required to include water quality-based effluent limitations (WQBELs) to attain and maintain applicable numeric and narrative water quality criteria to protect the beneficial uses of the receiving water. When numeric water quality objectives have not been established, but a discharge has the reasonable potential to cause or contribute to an excursion above a narrative criterion, WQBELs may be established using one or more of the three methods described in 40 CFR 122.44(d) – 1) WQBELs may be established on a case-by-case basis using USEPA criteria guidance published under CWA §304(a); 2) WQBELs may be established using an indicator parameter for the pollutant of concern; or 3) WQBELs may be established using a calculated water quality criterion derived from a proposed State criterion or an explicit State policy or regulation interpreting its narrative criterion.

## A. Discharge Prohibitions

- 1. Discharge Prohibition III.A** (No discharge at a location or in a manner except as described by the Order). The Order authorizes a single, specific point of discharge to surface waters, and the limitations and conditions established by the Order are based on specific information provided by the Discharger and gained by the Central Coast Water Board through site visits, monitoring reports, and other information. Discharges to surface waters at locations not contemplated by this Order or discharges of a character not contemplated by this Order are therefore viewed as inconsistent with CWA §402's prohibition against discharges of pollutants except in compliance with the Act's permit requirements, effluent limitations, and other enumerated provisions. This prohibition has been retained from Order No. R3-2006-0026.
- 2. Discharge Prohibition III.B** (The bypass or overflow of wastewater or wastes to surface waters or surface water drainage courses is prohibited, except as provided for in Attachment D, Standard Provision I.G (Bypass), is prohibited.). The discharge of untreated or partially treated wastewater from the Discharger's collection, treatment, or disposal facilities represents an unauthorized bypass pursuant to 40 CFR 122.41(m) or an unauthorized discharge, which poses a threat to human health and/or aquatic life, and therefore, is explicitly prohibited by the Order. This prohibition has been retained from Order No. R3-2006-0026.
- 3. Discharge Prohibition III.C** (The discharge of any waste not specifically regulated by this Order is prohibited). Because limitations and conditions of the Order have been prepared based on specific information provided by the Discharger and specific wastes described by the Discharger, the limitations and conditions of the Order do not adequately address waste streams not contemplated during drafting of the Order. To prevent the discharge of such waste streams that may be inadequately regulated, the Order prohibits the discharge of any waste that was not described by to the Central Coast Water Board during the process of permit reissuance. This prohibition has been retained from Order No. R3-2006-0026.

Discharge Prohibitions III.C and III.E from the previous Order have not been retained in this Order because storm water is no longer covered under this Order and the Discharger is required to seek coverage under the storm water General Permit.

## B. Technology-Based Effluent Limitations

### 1. Scope and Authority

NPDES regulations at 40 CFR 122.44(a) require that permits include applicable technology-based limitations and standards. Where the USEPA has not yet developed technology based standards for a particular industry or a particular pollutant, CWA §402(a)(1) and USEPA regulations at 40 CFR 125.3 authorize the use of best professional judgment (BPJ) to derive technology-based effluent limitations on a case-by-case basis. When BPJ is used, the permit writer must consider specific factors outlined at 40 CFR 125.3.

## 2. Applicable Technology-Based Effluent Limitations

- a. **Federal Regulations.** USEPA has not established standards of performance (technology-based limitations and standards) for bulk petroleum storage, loading, and transfer facilities.
- b. **Ocean Plan.** The Ocean Plan is applicable, in its entirety, to point source discharges to the ocean. Therefore, the discharge of wastewater to the Pacific Ocean at Discharge Point No. 001 is subject to the Ocean Plan.

The Ocean Plan establishes WQOs, general requirements for management of waste discharged to the ocean, effluent quality requirements for waste discharges, discharge prohibitions, and general provisions. Further, Table A of the Ocean Plan establishes effluent limitations for industrial discharges for which Effluent Limitations Guidelines (ELGs) have not been established by the USEPA. Since no ELGs exist for bulk petroleum storage, loading, and transfer facilities, numeric effluent limitations based on Table A of the Ocean Plan are applicable to the Facility for discharges from Discharge Point No. 001. This is consistent with Order No. R3-2006-0026. All technology-based effluent limitations from the previous Order have been retained. Additionally, Table A of the Ocean Plan also includes an effluent limitation for TSS, which was not included in the previous Order but is applicable to this Facility. In accordance with the Ocean Plan, this Order establishes effluent limitations for TSS at Discharge Point No. 001. The effluent limitations from the Ocean Plan applicable to the Facility are summarized in Table F-8, below.

**Table F-8. Effluent Limitations Based on Table A of the Ocean Plan**

Parameter	Units	Effluent Limitations		
		Average Monthly	Average Weekly	Maximum Daily
Oil and Grease	mg/L	25	40	75
Total Suspended Solids	mg/L	[1]		
Settleable Solids	ml/l	1.0	1.5	3.0
pH	s.u.	6.0 – 9.0		
Turbidity	NTU	75	100	225

[1] The Discharger shall, as a 30-day average, remove 75% of suspended solids from the influent stream before discharging wastewaters to the ocean, except that the effluent limitation to be met shall not be lower than 60 mg/L.

Effluent limitations derived from Ocean Plan Table A shall apply to the Discharger’s total effluent, of whatever origin (i.e., gross discharge, not net), except where otherwise specified in the Ocean Plan.

## C. Water Quality-Based Effluent Limitations (WQBELs)

### 1. Scope and Authority

NPDES regulations at 40 CFR 122.44(d) require that permits include limitations more stringent than applicable federal technology-based requirements where

necessary to achieve applicable water quality standards, including numeric and narrative objectives within a standard.

The process for determining “reasonable potential” and calculating WQBELs, when necessary, is intended to protect the designated uses of receiving waters as specified in the Basin and Ocean Plans and achieve applicable WQOs and criteria that are contained in the Basin Plan and in other applicable State and federal rules, plans, and policies, including applicable water quality criteria from the Ocean Plan.

Where reasonable potential has been established for a pollutant, but there is no numeric criterion or objective for the pollutant, WQBELs must be established in accordance with the requirements of 40 CFR 122.44(d)(1)(vi), using (1) USEPA criteria guidance under CWA §304(a), supplemented where necessary by other relevant information; (2) an indicator parameter for the pollutant of concern; or (3) a calculated numeric water quality criterion, such as a proposed state criterion or policy interpreting the state’s narrative criterion, supplemented with other relevant information.

## **2. Applicable Beneficial Uses and Water Quality Criteria and Objectives**

Beneficial uses for ocean waters of the Central Coast Region are established by the Basin Plan and Ocean Plan and are described in section III.C of the this Fact Sheet.

Water quality criteria applicable to ocean waters of the Region are established by the Ocean Plan, which includes WQOs for bacterial characteristics, physical characteristics, and radioactivity. The WQOs from the Ocean Plan are incorporated as receiving water limitations in this Order. In addition, Table B of the Ocean Plan contains numeric WQOs for 83 toxic pollutants for the protection of marine aquatic life and human health. Pursuant to NPDES regulations at 40 CFR 122.44(d)(1), and in accordance with procedures established by the Ocean Plan (2009), the Central Coast Water Board has performed a reasonable potential analysis (RPA) to determine the need for effluent limitations for Table B toxic pollutants.

## **3. Determining the Need for WQBELs**

Procedures for performing a Reasonable Potential Analysis (RPA) for ocean dischargers are described in Section III.C and Appendix VI of the Ocean Plan. The procedure is a statistical method that projects an effluent data set while taking into account the averaging period of WQOs, the long term variability of pollutants in the effluent, limitations associated with sparse data sets, and uncertainty associated with censored data sets. The procedure assumes a lognormal distribution of the effluent data set, and compares the 95<sup>th</sup> percentile concentration at 95 percent confidence of each Table B pollutant, accounting for dilution, to the applicable water quality criterion. The RPA results in one of three following endpoints:

Endpoint 1 - There is “reasonable potential”. An effluent limitation must be developed for the pollutant. Effluent monitoring for the pollutant, consistent with the monitoring frequency in Appendix III (Ocean Plan), is required.

- Endpoint 2 - There is no “reasonable potential”. An effluent limitation is not required for the pollutant. Appendix III (Ocean Plan) effluent monitoring is not required for the pollutant; the Central Coast Board, however, may require occasional monitoring for the pollutant or for whole effluent toxicity as appropriate.
- Endpoint 3 - The RPA is inconclusive. Monitoring for the pollutant or whole effluent toxicity testing consistent with the monitoring frequency in Appendix III (Ocean Plan) is required. An existing effluent limitation for the pollutant shall remain in the permit, otherwise the permit shall include a reopener clause to allow for subsequent modification of the permit to include an effluent limitation if monitoring establishes that the discharge causes, has the reasonable potential to cause, or contribute to an excursion above a Table B water quality objective.

The State Water Board has developed a reasonable potential calculator, which is available at:

[http://www.swrcb.ca.gov/water\\_issues/programs/ocean/docs/trirev/stakeholder050505/rpcalc20\\_setup.exe](http://www.swrcb.ca.gov/water_issues/programs/ocean/docs/trirev/stakeholder050505/rpcalc20_setup.exe)

The calculator (RPcalc 2.0) was used in the development of this Order and considers several pathways in the determination of reasonable potential.

**a. First Path**

If available information about the receiving water or the discharge supports a finding of reasonable potential without analysis of effluent data, the Central Coast Water Board may decide that WQBELs are necessary after a review of such information. Such information may include: the facility or discharge type, solids loading, lack of dilution, history of compliance problems, potential toxic effects, fish tissue data, §303(d) status of the receiving water, the presence of threatened or endangered species or their critical habitat, or other information.

**b. Second Path**

If any pollutant concentration, adjusted to account for dilution, is greater than the most stringent applicable WQO, there is reasonable potential for that pollutant.

**c. Third Path**

If the effluent data contains three or more detected and quantified values (i.e., values that are at or above the minimum level (ML)), and all values in the data set are at or above the ML, a parametric RPA is conducted to project the range of possible effluent values. The 95<sup>th</sup> percentile concentration is determined at 95 percent confidence for each pollutant, and compared to the most stringent applicable water quality objective to determine reasonable potential. A

parametric analysis assumes that the range of possible effluent values is distributed lognormally. If the 95<sup>th</sup> percentile value is greater than the most stringent applicable water quality objective, there is reasonable potential for that pollutant.

**d. Fourth Path**

If the effluent data contains three or more detected and quantified values (i.e., values that are at or above the ML), but at least one value in the data set is less than the ML, a parametric RPA is conducted according to the following steps.

- i. If the number of censored values (those expressed as a “less than” value) account for less than 80 percent of the total number of effluent values, calculate the  $M_L$  (the mean of the natural log of transformed data) and  $S_L$  (the standard deviation of the natural log of transformed data) and conduct a parametric RPA, as described above for the Third Path.
- ii. If the total number of censored values account for 80 percent of the total number of effluent values, conduct a non-parametric RPA, as described below for the Fifth Path. (A non-parametric analysis becomes necessary when the effluent data is limited, and no assumptions can be made regarding its possible distribution.)

**e. Fifth Path**

A non-parametric RPA is conducted when the effluent data set contains less than three detected and quantified values, or when the effluent data set contains three or more detected and quantified values but the number of censored values accounts for 80 percent or more of the total of effluent values. A non-parametric analysis is conducted by ordering the data, comparing each result to the applicable WQO, and accounting for ties. The sample number is reduced by one for each tie, when the dilution-adjusted method detection limit (MDL) is greater than the water quality objective. If the adjusted sample number, after accounting for ties, is greater than 15, the pollutant has no reasonable potential to exceed the WQO. If the sample number is 15 or less, the RPA is inconclusive, monitoring is required, and any existing effluent limits in the expiring permit are retained.

In this case, an RPA was conducted using effluent monitoring data from May 2010 until December 2010 because the Discharger has not discharged since December 2010. The implementation provisions for Table B in Section III.C of the Ocean Plan specify that the minimum initial dilution is the lowest average initial dilution within any single month of the year. Dilution estimates shall be based on observed waste flow characteristics, observed receiving water density structure, and the assumption that no currents of sufficient strength to influence the initial dilution process flow across the discharge structure. Order No. R3-2006-0026 determined the minimum initial dilution factor ( $D_m$ ) for the discharge to be 15 to 1 (seawater to effluent). The Discharger has indicated that no additions or modifications to the Facility have been proposed that would alter the previously determined dilution characteristics.



Therefore, the previous Dm of 15 to 1 will be retained from the current Order and applied to WQBELs established herein. If the actual dilution ratio is found to be different, then the ratio will be recalculated and this Order may be reopened when and as appropriate.

A summary of the RPA results is provided below.

**Table F-9. RPA Results**

Parameter	Units	n <sup>[1]</sup>	MEC <sup>[2],[3]</sup>	Most Stringent Criteria	Background	RPA Endpoint <sup>[4]</sup>
Arsenic	µg/L	1	6.8	8 <sup>[5]</sup>	3 <sup>[6]</sup>	3
Cadmium	µg/L	1	0.03	1 <sup>[5]</sup>	0	3
Chromium, Total Recoverable	µg/L	1	0.34	2 <sup>[5]</sup>	0	3
Copper	µg/L	1	6.1	3 <sup>[5]</sup>	2 <sup>[6]</sup>	3
Lead	µg/L	1	0.41	2 <sup>[5]</sup>	0	3
Mercury	µg/L	1	0.001	0.04 <sup>[5]</sup>	0.0005 <sup>[6]</sup>	3
Nickel	µg/L	1	1.0	5 <sup>[5]</sup>	0	3
Selenium	µg/L	1	1.3	15 <sup>[5]</sup>	0	3
Silver	µg/L	1	<0.2	0.7 <sup>[5]</sup>	0.16 <sup>[6]</sup>	3
Zinc	µg/L	1	22	20 <sup>[5]</sup>	8 <sup>[6]</sup>	3
Cyanide	µg/L	1	<3.0	1 <sup>[5]</sup>	0	3
Total Residual Chlorine	µg/L	NA	--	2 <sup>[5]</sup>	0	3
Ammonia	µg/L	1	1,600	600 <sup>[5]</sup>	0	3
Acute Toxicity	TUa	NA	--	0.3 <sup>[7]</sup>	0	3
Chronic Toxicity	TUc	NA	--	1 <sup>[7]</sup>	0	3
Phenolic Compounds <sup>[8]</sup>	µg/L	3	33	30 <sup>[5]</sup>	0	3
Chlorinated Phenolics <sup>[9]</sup>	µg/L	2	<0.93	1 <sup>[5]</sup>	0	3
Endosulfan <sup>[10]</sup>	µg/L	1	<0.01	0.009 <sup>[5]</sup>	0	3
Endrin	µg/L	1	<0.01	0.002 <sup>[5]</sup>	0	3
HCH <sup>[11]</sup>	µg/L	NA	--	0.004 <sup>[5]</sup>	0	3
Radioactivity	pCi/L	--	--	<sup>[12]</sup>	0	--
Acrolein	µg/L	1	<1.7	220 <sup>[13]</sup>	0	3
Antimony	µg/L	1	0.55	1,200 <sup>[13]</sup>	0	3
Bis(2-chloroethoxy)methane	µg/L	1	<0.93	4.4 <sup>[13]</sup>	0	3
Bis(2-chloroisopropyl)ether	µg/L	1	<0.81	1,200 <sup>[13]</sup>	0	3
Chlorobenzene	µg/L	1	<0.18	570 <sup>[13]</sup>	0	3
Chromium (III)	µg/L	1	0.34	190,000 <sup>[13]</sup>	0	3
Di-n-butyl phthalate	µg/L	1	<0.91	3,500 <sup>[13]</sup>	0	3
Dichlorobenzenes <sup>[14]</sup>	µg/L	1	<0.27	5,100 <sup>[13]</sup>	0	3
Diethyl phthalate	µg/L	1	<0.86	33,000 <sup>[13]</sup>	0	3
Dimethyl phthalate	µg/L	1	<0.97	820,000 <sup>[13]</sup>	0	3
4,6-Dinitro-2-methylphenol	µg/L	1	<0.91	220 <sup>[12]</sup>	0	3
2,4-Dinitrophenol	µg/L	1	<0.83	4.0 <sup>[12]</sup>	0	3
Ethylbenzene	µg/L	15	0.8	4,100 <sup>[13]</sup>	0	3
Fluoranthene	µg/L	1	<0.03	15 <sup>[13]</sup>	0	3
Hexachlorocyclopentadiene	µg/L	2	<0.9	58 <sup>[13]</sup>	0	3
Nitrobenzene	µg/L	1	<0.95	4.9 <sup>[13]</sup>	0	3
Thallium	µg/L	1	<0.2	2 <sup>[13]</sup>	0	3

Parameter	Units	n <sup>[1]</sup>	MEC <sup>[2],[3]</sup>	Most Stringent Criteria	Background	RPA Endpoint <sup>[4]</sup>
Toluene	µg/L	15	2.8	85,000 <sup>[13]</sup>	0	3
Tributyltin	µg/L	1	<0.0007	0.0014 <sup>[13]</sup>	0	3
1,1,1-Trichloroethane	µg/L	2	<0.19	540,000 <sup>[13]</sup>	0	3
Acrylonitrile	µg/L	1	<0.69	0.10 <sup>[13]</sup>	0	3
Aldrin	µg/L	1	<0.004	0.000022 <sup>[13]</sup>	0	3
Benzene	µg/L	15	0.7	5.9 <sup>[13]</sup>	0	3
Benzidine	µg/L	1	<5.0	0.000069 <sup>[13]</sup>	0	3
Beryllium	µg/L	1	<0.082	0.033 <sup>[13]</sup>	0	3
Bis(2-chloroethyl) ether	µg/L	NA	--	0.045 <sup>[13]</sup>	0	3
Bis(2-ethylhexyl) phthalate	µg/L	1	<0.95	3.5 <sup>[13]</sup>	0	3
Carbon tetrachloride	µg/L	1	<0.16	0.90 <sup>[13]</sup>	0	3
Chlordane <sup>[15]</sup>	µg/L	1	<0.005	0.000023 <sup>[13]</sup>	0	3
Chlorodibromomethane	µg/L	NA	--	8.6 <sup>[13]</sup>	0	3
Chloroform	µg/L	1	<0.19	130 <sup>[13]</sup>	0	3
DDT <sup>[16]</sup>	µg/L	1	<0.004	0.00017 <sup>[13]</sup>	0	3
1,4-Dichlorobenzene	µg/L	1	<0.18	18 <sup>[13]</sup>	0	3
3,3-Dichlorobenzidine	µg/L	1	<5.0	0.0081 <sup>[13]</sup>	0	3
1,2-Dichloroethane	µg/L	1	<0.18	28 <sup>[13]</sup>	0	3
1,1-Dichloroethylene	µg/L	1	<0.21	0.9 <sup>[13]</sup>	0	3
Dichlorobromomethane	µg/L	NA	--	6.2 <sup>[13]</sup>	0	3
Dichloromethane	µg/L	NA	--	450 <sup>[13]</sup>	0	3
1,3-Dichloropropene	µg/L	NA	--	8.9 <sup>[13]</sup>	0	3
Dieldrin	µg/L	1	<0.004	0.00004 <sup>[13]</sup>	0	3
2,4-Dinitrotoluene	µg/L	1	<0.5	2.6 <sup>[13]</sup>	0	3
1,2-Diphenylhydrazine	µg/L	1	<0.9	0.16 <sup>[13]</sup>	0	3
Halomethanes <sup>[17]</sup>	µg/L	NA	--	130 <sup>[13]</sup>	0	3
Heptachlor	µg/L	1	<0.005	0.00005 <sup>[13]</sup>	0	3
Heptachlor Epoxide	µg/L	NA	--	0.00002 <sup>[13]</sup>	0	3
Hexachlorobenzene	µg/L	1	<0.91	0.00021 <sup>[13]</sup>	0	3
Hexachlorobutadiene	µg/L	1	<0.92	14 <sup>[13]</sup>	0	3
Hexachloroethane	µg/L	1	<0.94	2.5 <sup>[13]</sup>	0	3
Isophorone	µg/L	1	<0.93	730 <sup>[13]</sup>	0	3
N-nitrosodimethylamine	µg/L	1	<0.88	7.3 <sup>[13]</sup>	0	3
N-nitrosodi-N-propylamine	µg/L	NA	--	0.38 <sup>[13]</sup>	0	3
N-nitrosodiphenylamine	µg/L	1	<0.83	2.5 <sup>[13]</sup>	0	3
PAHs <sup>[18]</sup>	µg/L	15	<0.1	0.0088 <sup>[13]</sup>	0	3
PCBs <sup>[19]</sup>	µg/L	1	<0.05	0.000019 <sup>[13]</sup>	0	3
TCDD equivalents <sup>[20]</sup>	pg/L	1	<3.27	0.0039 <sup>[13]</sup>	0	3
1,1,2,2-Tetrachloroethane	µg/L	1	<0.16	2.3 <sup>[13]</sup>	0	3
Tetrachloroethylene	µg/L	1	<0.19	2.0 <sup>[13]</sup>	0	3
Toxaphene	µg/L	1	<0.2	0.00021 <sup>[13]</sup>	0	3
Trichloroethylene	µg/L	1	<0.2	27 <sup>[13]</sup>	0	3
1,1,2-Trichloroethane	µg/L	1	<0.16	9.4 <sup>[13]</sup>	0	3
2,4,6-Trichlorophenol	µg/L	1	<0.97	0.29 <sup>[13]</sup>	0	3
Vinyl Chloride	µg/L	1	<0.25	36 <sup>[13]</sup>	0	3

Parameter	Units	n <sup>[1]</sup>	MEC <sup>[2],[3]</sup>	Most Stringent Criteria	Background	RPA Endpoint <sup>[4]</sup>
-----------	-------	------------------	------------------------	-------------------------	------------	-----------------------------

NA = Not Available

- [1] Number of data points available for the RPA.
- [2] If there is a detected value, the highest reported value is summarized in the table. If there are no detected values, the lowest MDL is summarized in the table.
- [3] Note that the reported MEC does not account for dilution. The RPA does account for dilution; therefore it is possible for a parameter with an MEC in exceedance of the most stringent criteria not to present a RP (i.e. Endpoint 1).
- [4] End Point 1 – RP determined, limit required, monitoring required.  
End Point 2 – Discharger determined not to have RP, monitoring may be established.  
End Point 3 – RPA was inconclusive, carry over previous limits if applicable, and establish monitoring.
- [5] Based on the 6-Month Median in the Table B of the Ocean Plan.
- [6] Background concentrations contained in Table C of the Ocean Plan.
- [7] Based on the Daily Maximum in Table B of the Ocean Plan.
- [8] Non-chlorinated phenolic compounds represent the sum of 2,4-dimethylphenol; 4,6-dinitro-2-methylphenol; 2,3-dinitrophenol; 2-methylphenol; 4-methylphenol; 2-nitrophenol; 4-nitrophenol, and phenol.
- [9] Chlorinated phenolic compounds represent the sum of 4-chloro-3-methylphenol; 2-chlorophenol; pentachlorophenol; 2,4,5-trichlorophenol; and 2,4,6-trichlorophenol.
- [10] Endosulfan represents the sum of alpha-endosulfan, beta-endosulfan, and endosulfan sulfate.
- [11] HCH (hexachlorocyclohexane) represents the sum of the alpha, beta, gamma (Lindane), and delta isomers of hexachlorocyclohexane.
- [12] Not to exceed limits specified in Title 17, Division 1, Chapter 5, Subchapter 4, Group 3, Article 3, Section 30253 of the California Code of Regulations. Radioactivity at levels that exceed the applicable criteria are not expected in the discharge.
- [13] Based on 30-Day Average in Table B of the Ocean Plan.
- [14] Dichlorobenzenes represent the sum of 1,2- and 1,3-dichlorobenzene.
- [15] Chlordane represents the sum of chlordane-alpha, chlordane-gamma, chlordene-alpha, chlordene-gamma, nonachlor-alpha, nonachlor-gamma, and oxychlordane.
- [16] DDT represents the sum of 4,4'DDT; 2,4'DDT; 4,4'DDE; 2,4'DDE; 4,4'DDD; and 2,4'DDD.
- [17] Halomethanes represent the sum of bromoform, bromomethane (methyl bromide), and chloromethane (methyl chloride).
- [18] PAHs (polynuclear aromatic hydrocarbons) represent the sum of acenaphthalene; anthracene; 1,2-benzanthracene; 3,4-benzofluoranthene; benzo[k]fluoranthene; 1,12-benzoperylene; benzo[a]pyrene; chrysene; dibenzo[a,h]anthracene; fluorene; indeno[1,2,3-cd]pyrene; phenanthrene; and pyrene.
- [19] PCBs (polychlorinated biphenyls) represent the sum of chlorinated biphenyls whose analytical characteristics resemble those of Aroclor-1016, Aroclor-1221, Aroclor-1232, Aroclor-1242, Aroclor-1248, Aroclor-1254, and Aroclor-1260.
- [20] TCDD equivalents represent the sum of concentrations of chlorinated dibenzodioxins (2,3,7,8-CDDs) and chlorinated dibenzofurans (2,3,7,8-CDFs) multiplied by their respective toxicity factors, as shown by the table below. USEPA Method 8280 may be used to analyze TCDD equivalents.

Isomer Group	Toxicity Equivalence Factor
2,3,7,8 – tetra CDD	1.0
2,3,7,8 – penta CDD	0.5
2,3,7,8 – hexa CDD	0.1
2,3,7,8 – hepta CDD	0.01
octa CDD	0.001
2,3,7,8 – tetra CDF	0.1
1,2,3,7,8 – penta CDF	0.05
2,3,4,7,8 – penta CDF	0.5
2,3,7,8 – hexa CDFs	0.1
2,3,7,8 – hepta CDFs	0.01
Octa CDF	0.001

As detailed in Table F-9, all pollutants resulted in Endpoint 3. Thus, all effluent limitations from the previous Order have been retained in this Order. Additionally, chlorodibromomethane, dichlorobromomethane, heptachlor epoxide, and n-nitrosodi-n-propylamine did not have effluent limitations or monitoring requirements in the previous Order and there was insufficient data to determine if they have reasonable potential; therefore, this Order establishes monitoring requirements for

chlorodibromomethane, dichlorobromomethane, heptachlor epoxide, and n-nitrosodi-n-propylamine, as described in section IV of the MRP (Attachment E), in order to gather data for use in RPAs for future permit renewals.

**4. WQBEL Calculations**

- a. From the Table B WQOs in the Ocean Plan, effluent limitations in Order No. R3-2006-0026 were calculated according to the following equation for all pollutants, except for acute toxicity (if applicable) and radioactivity:

$$C_e = C_o + D_m (C_o - C_s) \text{ where,}$$

$C_e$  = the effluent limitation ( $\mu\text{g/L}$ )

$C_o$  = the WQO to be met at the completion of initial dilution ( $\mu\text{g/L}$ )

$C_s$  = background seawater concentration

$D_m$  = minimum probable initial dilution expressed as parts seawater per part wastewater

- b. Initial dilution ( $D_m$ ) has been determined to be 15 to 1 by the Central Coast Water Board.

- c. Table C of the Ocean Plan establishes background concentrations for some pollutants to be used when determining reasonable potential (represented as “ $C_s$ ”). In accordance with Table B implementing procedures,  $C_s$  equals zero for all pollutants not established in Table C. The background concentrations provided in Table C are summarized below:

**Table F-10. Pollutants Having Background Concentrations**

Pollutant	Background Seawater Concentration
Arsenic	3 $\mu\text{g/L}$
Copper	2 $\mu\text{g/L}$
Mercury	0.0005 $\mu\text{g/L}$
Silver	0.16 $\mu\text{g/L}$
Zinc	8 $\mu\text{g/L}$

- d. A summary of WQBELs established for Discharge Point No. 001 in this Order are provided in Table F-11a – Table F-11c, below.

**Table F-11a. Effluent Limitations, Protection of Marine Aquatic Life**

Parameter	Units	6-Month Median <sup>[1]</sup>	Daily Maximum <sup>[2]</sup>	Instantaneous Maximum <sup>[3]</sup>
Arsenic, Total Recoverable	$\mu\text{g/L}$	80	470	1,200
Cadmium, Total Recoverable	$\mu\text{g/L}$	20	60	160
Chromium (VI), Total Recoverable <sup>[4]</sup>	$\mu\text{g/L}$	30	130	320
Copper, Total Recoverable	$\mu\text{g/L}$	20	160	450

Parameter	Units	6-Month Median <sup>[1]</sup>	Daily Maximum <sup>[2]</sup>	Instantaneous Maximum <sup>[3]</sup>
Lead, Total Recoverable	µg/L	30	130	320
Mercury, Total Recoverable	µg/L	0.63	2.6	6.4
Nickel, Total Recoverable	µg/L	80	320	800
Selenium, Total Recoverable	µg/L	240	960	2,400
Silver, Total Recoverable	µg/L	10	40	110
Zinc, Total Recoverable	µg/L	200	1,200	3,100
Cyanide, Total Recoverable <sup>[4]</sup>	µg/L	20	60	160
Total Residual Chlorine <sup>[6]</sup>	µg/L	30	130	960
Ammonia (as N)	µg/L	9,600	38,000	96,000
Phenolic Compounds (non-chlorinated)	µg/L	480	1,900	4,800
Chronic Toxicity	TUc	--	16.0	--
Chlorinated Phenolics	µg/L	20	60	160
Endosulfan	µg/L	0.14	0.29	0.43
Endrin	µg/L	0.03	0.06	0.10
HCH	µg/L	0.06	0.13	0.19
Radioactivity		[7]		

[1] The six-month median shall apply as a moving median of daily values for any 180-day period in which daily values represent flow weighted average concentrations within a 24-hour period. For intermittent discharges, the daily value shall be considered equal to zero for days on which no discharge occurred. The six-month median limit on daily mass emissions shall be determined using the six-month median effluent concentration  $C_e$  and the observed flow rate,  $Q$ , in million gallons per day (MGD).

[2] The daily maximum shall apply to flow weighted 24-hour composite samples. The daily maximum mass emission shall be determined using the daily maximum effluent concentration limit as  $C_e$  and the observed flow rate,  $Q$ , in MGD.

[3] The instantaneous maximum shall apply to grab sample determinations.

[4] The Discharger may, at their option, meet this limitation as a total chromium limitation.

[5] If a Discharger can demonstrate to the satisfaction of the Central Coast Water Board (subject to USEPA approval) that an analytical method is available to reliably distinguish between strongly and weakly complexed cyanide, effluent limitations for cyanide may be met by the combined measurement of free cyanide, simple alkali metal cyanides, and weakly complexed organometallic cyanide complexes. In order for the analytical method to be acceptable, the recovery of free cyanide from metal complexes must be comparable to that achieved by the approved method in 40 CFR 136.

[6] Water quality objectives for total chlorine residual applying to intermittent discharges not exceeding two hours shall be determined using the following equation:

$$\log(y) = -0.43 (\log x) + 1.8$$

where:  $y$  = the water quality objective (in µg/L) to apply when chlorine is being discharged

$x$  = the duration of uninterrupted chlorine discharges in minutes

The applicable effluent limitation must then be determined using Equation No. 1 from the Ocean Plan.

[7] Radioactivity is not to exceed limits specified in Title 17, Division 1, Chapter 5, Subchapter 4, Group 3, Article 3, Section 30253 of the California Code of Regulations. Reference to Section 30253 is prospective including future changes to incorporate provisions of federal law, as the changes take effect.

**Table F-11b. Effluent Limitations, Protection of Human Health – Non-Carcinogens**

Parameter	Units	30-day Average
Acrolein	µg/L	3,500

Parameter	Units	30-day Average
Antimony	µg/L	19,000
Bis(2-Chloroethoxy)Methane	µg/L	70
Bis(2-Chloroisopropyl)Ether	µg/l	19,000
Chlorobenzene	µg/L	9,100
Chromium (III)	µg/L	3,000,000
Di-n-butyl Phthalate	µg/L	56,000
Dichlorobenzenes	µg/L	82,000
Diethyl Phthalate	µg/L	530,000,000
Dimethyl Phthalate	µg/L	13,000
4,6-Dinitro-2-Methylphenol	µg/L	3,500
2,4-Dinitrophenol	µg/L	60
Ethylbenzene	µg/L	65,000
Fluoranthene	µg/L	240
Hexachlorocyclopentadiene	µg/L	930,000
Nitrobenzene	µg/L	80
Thallium	µg/L	220,000
Toluene	µg/L	1,400
Tributyltin	µg/L	20,000
1,1,1-Trichloroethane	µg/L	8,600

**Table F-11c. Effluent Limitations, Protection of Human Health – Carcinogens**

Parameter	Units	30-day Average
Acrylonitrile	µg/L	1.6
Aldrin	µg/L	0.00035
Benzene	µg/L	94.0
Benzidine	µg/L	0.001
Beryllium	µg/L	0.53
Bis(2-Chloroethyl)Ether	µg/L	0.72
Bis(2-Ethylhexyl)Phthalate	µg/L	56.0
Carbon Tetrachloride	µg/L	14.0
Chlordane <sup>[1]</sup>	ng/L	0.00037
Chloroform	µg/L	2,100
DDT <sup>[2]</sup>	µg/L	0.0027
1,4-Dichlorobenzene	µg/L	290
3,3'-Dichlorobenzidine	µg/L	0.13
1,2-Dichloroethane	µg/L	2,100
1,1-Dichloroethylene	µg/L	110,000
Dichloromethane	µg/L	7,200
1,3-Dichloropropene	µg/L	140
Dieldrin	µg/L	0.00064
2,4-Dinitrotoluene	µg/L	42

Parameter	Units	30-day Average
1,2-Diphenylhydrazine	µg/L	2.6
Halomethanes <sup>[3]</sup>	µg/L	2,100
Heptachlor <sup>[4]</sup>	µg/L	0.01
Hexachlorobenzene	µg/L	0.0034
Hexachlorobutadiene	µg/L	220
Hexachloroethane	µg/L	40
Isophorone	µg/L	2,400
N-Nitrosodimethylamine	µg/L	120
N-Nitrosodiphenylamine	µg/L	40
PAHs <sup>[5]</sup>	µg/L	0.14
PCBs <sup>[6]</sup>	µg/L	0.0003
TCDD Equivalents <sup>[7]</sup>	µg/L	6.0E-08
1,1,2,2-Tetrachloroethane	µg/L	19,000
Tetrachloroethylene	µg/L	1,600
Toxaphene	µg/L	0.0034
Trichloroethylene	µg/L	430
2,4,6-Trichlorophenol	µg/L	4.6
Vinyl Chloride	µg/L	580.0
1,1,2-Trichloroethane	µg/L	690,000

- [1] Chlordane shall mean the sum of chlordane-alpha, chlordane-gamma, nonachlor-alpha, nonachlor-gamma, and oxychlordane.
- [2] DDT shall mean the sum of 4,4'-DDT, 2,4'-DDT, 4,4'-DDE, 4,4'-DDD, and 2,4'-DDD.
- [3] Halomethanes shall mean the sum of bromoform, bromomethane (methyl bromide), chloromethane (methyl chloride), chlorodibromomethane, and dichlorobromomethane.
- [4] Heptachlor shall mean the sum of heptachlor and heptachlor epoxide.
- [5] PAHS (Polynuclear aromatic hydrocarbons) shall mean the sum of acenaphthylene, anthracene, 1,2-benzanthracene, 3,4-benzofluoranthene, benzo(k)fluoranthene, 1,12-benzoperylene, benzo(a)pyrene, chrysene, dibenzo(a,h)anthracene, fluorene, indeno(1,2,3-cd)pyrene, phenanthrene, pyrene.
- [6] PCBs (polychlorinated biphenyls) shall mean the sum of chlorinated biphenyls whose analytical characteristics resemble those of Aroclor-1016, Aroclor-1221, Aroclor-1232, Aroclor-1242, Aroclor-1248, Aroclor-1254, and Aroclor-1260.
- [7] TCDD Equivalents shall mean the sum of those concentrations of chlorinated dibenzodioxins (2,3,7,8-CDDs) and chlorinated dibenzofurans (2,3,7,8-CDFs) multiplied by their respective toxicity factors, as listed in Appendix I of the Ocean Plan.

Effluent limitations derived from Ocean Plan Table B shall apply to the Discharger's total effluent, of whatever origin (i.e., gross discharge, not net), except where otherwise specified in the Ocean Plan. Additionally, the discharge of waste shall not cause WQOs established in Table B to be exceeded in the receiving water upon completion of initial dilution, except that objectives indicated for radioactivity shall apply directly to the undiluted waste effluent.

### 5. Whole Effluent Toxicity (WET)

Whole effluent toxicity limitations protect receiving water quality from the aggregate toxic effect of a mixture of pollutants in the effluent. WET tests measure the degree

of response of exposed aquatic test organisms to an effluent. The WET approach allows dischargers to protect the narrative “no toxics in toxic amounts” criterion while implementing numeric criteria for toxicity. There are two types of WET tests – acute and chronic. An acute toxicity test is conducted over a short period and measures mortality. A chronic toxicity test is conducted over a longer period of time and may measure mortality, reproduction, and growth.

The Basin Plan specifies a narrative objective for toxicity, requiring that all waters be maintained free of toxic substances in concentrations that are toxic to, or which produce detrimental physiological responses in human, plant, animal, or aquatic life. Survival of aquatic organisms in surface waters subjected to a waste discharge or other controllable water quality conditions shall not be less than that for the same water body in areas unaffected by the waste discharge or for control water.

Toxicity testing is based on the minimum initial dilution factor for ocean waste discharges. The requirements for conducting testing for acute and chronic toxicity are explained in the Ocean Plan. According to the requirements, if the minimum initial dilution of the effluent falls below 100:1 at the edge of the mixing zone, then the dischargers shall conduct chronic toxicity testing. Since the minimum initial dilution of the effluent is 15:1 for the Discharger, only chronic toxicity is necessary. Consistent with the previous Order, this Order requires the Discharger to monitor the discharge for chronic toxicity once during the term of the permit.

The Discharger may be required to develop and implement a Toxicity Reduction Evaluation (TRE) Workplan, as described in section VI.C.2.a of the Order. When monitoring measures WET in the effluent above the limitations established by the Order, the Discharger must resample, if the discharge is continuing, and retest. The Executive Officer will then determine whether to initiate enforcement action, whether to require the Discharger to implement a TRE, or to implement other measures.

## **D. Final Effluent Limitations**

Final, technology-based and water quality-based effluent limitations established by the Order are discussed in the preceding sections of the Fact Sheet.

### **1. Satisfaction of Anti-Backsliding Requirements**

CWA §402(o)(2) and §303(d)(4) and federal regulations at 40 CFR 122.44(1) prohibit backsliding in NPDES permits. These anti-backsliding provisions require effluent limitations in a reissued permit to be as stringent as those in the previous permit, with some exceptions where limitations may be relaxed.

All effluent limitations from the previous Order for the applicable discharge from Discharge Point No. 001 are retained in this Order. Therefore, this Order satisfies applicable anti-backsliding provisions of the CWA, as all limitations and requirements in this Order are at least as stringent as those contained in the previous Order.



## 2. Satisfaction of Antidegradation Policy

Provisions of the Order are consistent with applicable anti-degradation policy expressed by NPDES regulations at 40 CFR 131.12 and by State Water Board Resolution No. 68-16. The limitations and conditions in this Order assure maintenance of the existing quality of receiving waters and do not authorize increased rates of discharge or increased pollutant loadings to the receiving water above that authorized by the previous Order.

Storm water requirements have not been carried over in this Order because storm water discharges from the Facility are no longer addressed under this Order.

## 3. Stringency of Requirements for Individual Pollutants

This Order contains both technology-based and WQBELs for individual pollutants. The technology-based effluent limitations consist of restrictions on oil and grease, total suspended solids, settleable solids, pH, and turbidity. Restrictions on these pollutants are discussed in section IV.B of the Fact Sheet. This Order's technology-based pollutant restrictions implement the minimum, applicable federal technology-based requirements. In addition, this Order contains effluent limitations more stringent than the minimum, federal technology-based requirements that are necessary to meet water quality standards. These limitations are not more stringent than required by the CWA.

## 4. Summary of Final Effluent Limitations – Discharge Point No. 001

Final technology and water quality based effluent limitations are summarized in sections IV.B and IV.C of this Fact Sheet. Additionally, the Discharger shall comply with the following:

- a. **Dry Weather Flow:** Effluent daily dry weather flow shall not exceed a monthly average of 0.21 MGD.
- b. Effluent shall be essentially free of materials and substances that:
  - i. Float or become floatable upon discharge;
  - ii. May form sediments that degrade benthic communities or other aquatic life;
  - iii. Accumulate to toxic levels in marine waters, sediments, or biota;
  - iv. Decrease the natural light to benthic communities and other marine life; or
  - v. Result in aesthetically undesirable discoloration of the ocean surface.

**E. Interim Effluent Limitations – Not Applicable**

**F. Land Discharge Effluent Limitations and Specifications – Not Applicable**

**G. Reclamation Specifications – Not Applicable**

**V. Rationale for Receiving Water Limitations**

**A. Surface Water**

Receiving water quality is a result of many factors, some unrelated to the discharge. This Order considers these factors and is designed to minimize the influence of the discharge on the receiving water. All receiving water limitations for Discharge Point No. 001 to the Pacific Ocean are retained from Order No. R3-2006-0026, with the exception of receiving water limitation in section V.A.1.f of the previous permit which stated “storm water discharges shall not adversely impact human health or the environment”. Additionally, the previous Order included receiving water effluent limitations for the discharge of storm water to Toro Creek. The receiving water limitations for Toro Creek are not retained because, as discussed in section VII.C.6.a of the Fact Sheet, this Order does not regulate storm water discharges and the Discharger is required to seek coverage under the State-wide industrial storm water General Permit.

**B. Groundwater – Not Applicable**

**VI. Rationale for Monitoring and Reporting Requirements**

NPDES regulations at 40 CFR 122.48 require that all NPDES permits specify requirements for recording and reporting monitoring results. CWC §13267 and 1§3383 also authorize the Central Coast Water Board to require technical and monitoring reports. The MRP, Attachment E of this Order, establishes monitoring and reporting requirements to implement federal and state requirements. The following provides the rationale for the monitoring and reporting requirements contained in the MRP for the Facility.

**A. Influent Monitoring Requirements**

Influent monitoring requirements for TSS have been added to this Order. In accordance with the Ocean Plan, this Order establishes effluent limitations for TSS, which states that if an effluent concentration is measured above 60 mg/L, the Discharger shall remove 75% of suspended solids from the influent stream before discharging to the ocean. Therefore, this Order establishes influent monitoring for TSS in order to determine compliance with TSS percent removal effluent limitations.

**B. Effluent Monitoring Requirements**

Effluent monitoring requirements from Order No. R3-2006-0026 for Discharge Point No. 001 are retained in this Order with the following exceptions:

1. This Order requires the Discharger to record and submit monitoring data for all Table B pollutants in micrograms/Liter ( $\mu\text{g/L}$ ) in order to reduce the potential for errors due to reported units.

Additionally, the following monitoring requirements have been established in this Order:

2. Effluent monitoring for chlorodibromomethane, dichlorobromomethane, heptachlor epoxide, and n-nitrosodi-n-propylamine have been established in order to collect data to determine reasonable potential in future permit renewals. These requirements are consistent with other Table B pollutant monitoring requirements.
3. Effluent monitoring requirements for vinyl chloride have been added to this Order in Order to determine compliance with effluent limitations and collect data for future RPAs. These requirements are consistent with other Table B pollutant monitoring requirements.

### **C. Internal Monitoring Requirements**

Internal monitoring is required for the primary pollutants of concern at the Facility in order to evaluate for potential treatment system breakthrough or for replacement of carbon media and rotation of GAC canisters. Internal monitoring requirements for M-INT-1 and M-INT-2 are retained from the previous Order, with the following exception:

1. To be consistent with monitoring for other Table B parameters, this Order requires the Discharger to report toluene and ethylbenzene in µg/L, rather than milligrams per liter (mg/L).

### **D. Whole Effluent Toxicity Testing Requirements**

Whole effluent toxicity (WET) limitations protect receiving water quality from the aggregate toxic effect of a mixture of pollutants in the effluent. Chronic toxicity testing is conducted over a long period of time and may measure mortality, reproduction, and/or growth. This Order retains limitations for chronic toxicity and monitoring requirements for chronic toxicity for Discharge Point No. 001.

### **E. Land Discharge Monitoring Requirements – Not Applicable**

### **F. Reclamation Monitoring Requirements – Not Applicable**

### **G. Receiving Water Monitoring Requirements – Not Applicable**

### **H. Other Monitoring Requirements**

#### **1. Ocean Outfall Inspection**

This Order retains the requirement of the previous Order to conduct annual visual inspections of the outfall and diffuser structure and provide a report of this inspection to the Central Coast Water Board regarding the system's physical integrity.

#### **2. Storm Water Monitoring**

This Order requires the Discharger to seek coverage under the General State Water Board Order No. 2014-0057-DWQ (NPDES General Permit No. CAS000001), which

includes monitoring requirements for storm water discharges, as described in section VII.C.6.a, below.

## **VII. Rationale for Provisions**

### **A. Standard Provisions**

Standard Provisions, which apply to all NPDES permits in accordance with 40 CFR 122.41, and additional conditions applicable to specified categories of permits in accordance with 40 CFR 122.42, are provided in Attachment D to the Order.

NPDES regulations at 40 CFR 122.41(a)(1) and (b - n) establish conditions that apply to all state-issued NPDES permits. These conditions must be incorporated into the permits either expressly or by reference. If incorporated by reference, a specific citation to the regulations must be included in the Order. 40 CFR 123.25(a)(12) allows the State to omit or modify conditions to impose more stringent requirements. In accordance with 40 CFR 123.25, this Order omits federal conditions that address enforcement authority specified in 40 CFR 122.41(j)(5) and (k)(2), because the enforcement authority under the Water Code is more stringent. In lieu of these conditions, this Order incorporates by reference CWC §13387(e).

### **B. Monitoring and Reporting Program (MRP) Requirements**

The Discharger shall comply with the MRP, and future revisions thereto, in Attachment E of this Order.

### **C. Special Provisions**

#### **1. Reopener Provisions**

The Order may be modified in accordance with the requirements set forth at 40 CFR 122 and 124, to include appropriate conditions or limits based on newly available information, or to implement any, new State WQOs that are approved by the USEPA. As effluent is further characterized through additional monitoring, and if a need for additional effluent limitations becomes apparent after additional effluent characterization, the Order will be reopened to incorporate such limitations.

#### **2. Special Studies and Additional Monitoring Requirements**

##### **a. Toxicity Reduction Requirements**

The requirement to perform a TRE, if the Executive Officer determines it to be appropriate, is retained from Order No. R3-2006-0026. When toxicity monitoring measures chronic toxicity in the effluent above the limitation established by the Order, the Discharger is required to increase monitoring frequency to once per week and submit the results within 15 days of the conclusion of each test to the Central Coast Water Board. When all monitoring results are available, the Executive Officer can determine whether to initiate enforcement action, whether

to require the Discharger to implement TRE requirements, or whether other measures are warranted.

### **3. Best Management Practices and Pollution Prevention**

#### **a. Pollutant Minimization Program**

The 2009 Ocean Plan establishes guidelines for the Pollutant Minimization Program (PMP). At the time of the proposed adoption of this Order, no known evidence was available that would require the Discharger to immediately develop and conduct a PMP. The Central Coast Water Board will notify the Discharger in writing if such a program becomes necessary. The 2009 Ocean Plan PMP language is included in this Order to provide guidance in the event that a PMP must be developed and implemented by the Discharger.

### **4. Construction, Operation, and Maintenance Specifications – Not Applicable**

### **5. Special Provisions for Municipal Facilities (POTWs Only) – Not Applicable**

### **6. Other Special Provisions**

- a. Discharges of Storm Water.** The previous Order regulated storm water discharges from the Facility and required the Discharger to comply with their SWPP Plan established in October 2000. However, the General State Water Board Order No. 2014-0057-DWQ, NPDES General Permit No. CAS000001, Waste Discharge Requirements for Storm Water Associated with Industrial Activities Excluding Construction Activities, states that when the individual or general NPDES permit for a discharger expires, the State Water Board or Central Coast Water Board may authorize coverage under the General Permit or another general NPDES permit. Additionally, the General Permit is intended to cover all new or existing storm water discharges, including petroleum bulk stations and terminals that have equipment cleaning operations areas and storage for raw materials. The decommissioning of this former oil tanker loading terminal will include offshore loading line flush water, equipment cleaning, onshore pipeline hydro-static test and flush water. Therefore, the Central Coast Water Board has determined that, based on the above discussion, requirements of the General Permit are applicable to this Facility and the Discharger shall seek coverage under the General Permit.
- b. Operation of GAC Canisters.** The granular activated carbon (GAC) system shall be monitored as specified in section V of this MRP. This provision is retained from the previous permit to ensure proper treatment of wastewater before being discharged from the Facility.
- c. Rescission of Order.** The Facility is in the process of decommissioning the Estero Marine Terminal facilities. Once decommissioning is complete and discharges from these efforts are terminated, the Central Coast Water Board may reopen the permit to revisit requirements set forth in this Order. This provision is consistent with the Reopener Provision (section VII.C.1 in this Fact

Sheet), which states that the Order may be reopened and modified based on newly available information. This provision is retained from the previous Order.

- d. Reevaluation of Effluent Limitations.** The Facility is in the process of decommissioning the Estero Marine Terminal facilities. The Discharger anticipates wastewater from equipment cleaning, flush water, groundwater, and hydro-static test and flush water to be treated and discharged at Discharge Point No. 001. The Discharger utilizes a temporary treatment system at the Facility and has the ability to increase flow if necessary. If future decommissioning activities require the Discharger to increase flow, the Central Coast Water Board may reopen the permit to revisit requirements set forth in this Order. This provision is consistent with the Reopener Provision (section VII.C.1 in this Fact Sheet), which states that the Order may be reopened and modified based on newly available information. This provision is established in this Order based on Section IV.I of the previous Order, which stated “any significant change in waste flow shall be cause for reevaluating effluent limitations”.

## **7. Compliance Schedules – Not Applicable**

## **VIII. Public Participation**

The Central Coast Central Coast Water Quality Control Board is considering the issuance of waste discharge requirements (WDRs) that will serve as a National Pollutant Discharge Elimination System (NPDES) permit for the Chevron Estero Marine Terminal. As a step in the WDR adoption process, Central Coast Water Board staff has developed tentative WDRs. The Central Coast Water Board encourages public participation in the WDR adoption process.

### **A. Notification of Interested Parties**

The Central Coast Water Board notified the Discharger and interested agencies and persons of its intent to prescribe waste discharge requirements for the discharge and provided them with an opportunity to submit their written comments and recommendations. Notification was provided by posting on the Central Coast Water Board’s website and posting at the facility.

The Central Coast Water Board’s web address is <http://www.waterboards.ca.gov/centralcoast/> where the public has been provided access to the agenda including any changes in dates and locations.

### **B. Written Comments**

Interested persons were invited to submit written comments concerning tentative WDRs as provided through the notification process. Comments are due either in person or by email or mail to the Executive Office at the Central Coast Water Board at:

Central Coast Water Board  
895 Aerovista Place, Suite 101  
San Luis Obispo, CA 93401

[centralcoast@waterboards.ca.gov](mailto:centralcoast@waterboards.ca.gov)

To be fully responded to by staff and considered by the Central Coast Water Board, the written comments are due at the Central Coast Water Board office by 5:00 p.m. on October 26, 2017. No public comments were received during the public comment period.

### C. Public Hearing

The Central Coast Water Board will hold a public hearing on the tentative WDRs during its regular Board meeting on the following date and time and at the following location:

Date: **December 7-8, 2017**  
Time: **8:30 a.m.**  
Location: **Central Coast Regional Water Quality Control Board  
895 Aerovista Place, Suite 101  
San Luis Obispo, CA 93401**

Interested persons are invited to attend. At the public hearing, the Central Coast Water Board will hear testimony, if any, pertinent to the discharge, WDRs, and permit. Oral testimony will be heard; however, for accuracy of the record, important testimony should be in writing.

Please be aware that dates and venues may change. Our Web address is <http://www.waterboards.ca.gov/centralcoast/> where you can access the current agenda for changes in dates and locations.

### D. Waste Discharge Requirements Petitions

Any aggrieved person may petition the State Water Resources Control Board to review the decision of the Central Coast Water Board regarding the final WDRs. The petition must be submitted within 30 days of the Central Coast Water Board's action to the following address:

State Water Resources Control Board  
Office of Chief Counsel  
P.O. Box 100, 1001 I Street  
Sacramento, CA 95812-0100

For instructions on how to file a petition for review, see:  
[http://www.waterboards.ca.gov/public\\_notices/petitions/water\\_quality/wqpetition\\_instr.shtml](http://www.waterboards.ca.gov/public_notices/petitions/water_quality/wqpetition_instr.shtml)

### E. Information and Copying

The Report of Waste Discharge (ROWD), related documents, tentative effluent limitations and special provisions, comments received, and other information are on file and may be inspected at the address above at any time between 8:00 a.m. and 5:00 p.m., Monday through Friday. Copying of documents may be arranged through the Central Coast Water Board by calling (805) 549-3147.

## **F. Register of Interested Persons**

Any person interested in being placed on the mailing list for information regarding the WDRs and NPDES permit should contact the Central Coast Water Board, reference this facility, and provide a name, address, and phone number.

## **G. Additional Information**

Requests for additional information or questions regarding this Order should be directed to Chris Mohs at (805) 549-3880 or [chris.mohs@waterboards.ca.gov](mailto:chris.mohs@waterboards.ca.gov) or Sheila Soderberg at (805) 542-3592 or [sheila.soderberg@waterboards.ca.gov](mailto:sheila.soderberg@waterboards.ca.gov).