

DRAFT

# Environmental Checklist and CEQA Addendum for the Zamora Pistachio Facility Project

Prepared for:

**Central Valley Regional Water  
Quality Control Board**

11020 Sun Center Drive, Suite 200  
Rancho Cordova, CA 95670

April 2024



DRAFT

# Environmental Checklist and CEQA Addendum for the Zamora Pistachio Facility Project

Prepared for:

**Central Valley Regional Water Quality Control Board**  
11020 Sun Center Drive, Suite 200  
Rancho Cordova, CA 95670

Contact:

**Chris Moskal and Kennedy Knight**

Prepared by:



**Ascent Environmental**

455 Capitol Mall, Suite 300  
Sacramento, CA 95814

Contact:

**Sarah Henningsen**  
Project Manager

April 2024



# TABLE OF CONTENTS

Section	Page
LIST OF ABBREVIATIONS .....	II
1 INTRODUCTION .....	1
2 PROJECT DESCRIPTION .....	3
2.1 Project Location .....	3
2.2 Project Objectives.....	3
2.3 Project Elements .....	5
2.4 Potential Permits and Approvals Required.....	11
2.5 Previous Environmental Documents.....	12
3 EVALUATION OF ENVIRONMENTAL IMPACTS .....	13
I. Aesthetics .....	15
II. Agricultural and Forest Resources.....	17
III. Air Quality .....	19
IV. Biological Resources .....	21
V. Cultural Resources .....	23
VI. Energy .....	25
VII. Geology and Soils.....	26
VIII. Greenhouse Gas Emissions .....	28
IX. Hazards and Hazardous Materials .....	29
X. Hydrology and Water Quality.....	32
XI. Land Use and Planning .....	39
XII. Mineral Resources .....	40
XIII. Noise .....	41
XIV. Population and Housing.....	43
XV. Public Services .....	44
XVI. Recreation.....	46
XVII. Transportation.....	47
XVIII. Tribal Cultural Resources.....	51
XIX. Utilities and Service Systems .....	52
XX. Wildfire .....	54
4 CONCLUSION .....	57
5 REFERENCES.....	59
 Appendices	
A Yolo County Documentation of CEQA Compliance (Notice of Exemption and Site Plan Review)	
B Report of Waste Discharge	
 Figures	
Figure 2-1 Project Location .....	4
Figure 2-2 Project Site Plan .....	7
Figure 2-3 Harvest Wastewater Flowchart .....	9
 Tables	
Table 2-1 Projected Wastewater Flows per Year.....	9

## LIST OF ABBREVIATIONS

AG	Agricultural
A-N	Agricultural Intensive
ARB	California Air Resources Board
AST	above ground storage tank
ATC	Authority to Construct
BMP	best management practice
BPTC	best practical treatment or control
CCR	California Code of Regulations
CEQA	California Environmental Quality Act
CERS	California Environmental Reporting System
CNG	compressed natural gas
CR	County Road
DO	dissolved oxygen
EIR	environmental impact report
gpm	gallons per minute
HMBP	Hazardous Materials Business Plan
I-5	Interstate 5
LAA	land application area
LOS	level of service
MCL	maximum contaminant level
mg	million gallons
mg/y	million gallons per year
NOE	Notice of Exemption
NOP	notice of preparation
NPDES	National Pollutant Discharge Elimination System
O&M plan	operations and maintenance plan
P&O	Prioritization and Optimization
PERP	Portable Equipment Registration Program
PG&E	Pacific Gas and Electric Company
PRC	Public Resources Code
PTO	Permit to Operate
SCP	Salt Control Program
SED	substitute environmental documentation
SNMP	Salt and Nitrate Management Plan
SPCC	Spill Prevention, Control, and Countermeasure
SWPPP	Storm Water Pollution Prevention Plan
TCRs	tribal cultural resources
VMT	vehicle miles traveled
WDID #	Waste Discharge Identification Number
WDRs	Waste Discharge Requirements
WWTF	wastewater treatment facility
YCEH	Yolo County Environmental Health
Yolo County General Plan	County of Yolo 2030 Countywide General Plan
YSAQMD	Yolo-Solano Air Quality Management District

# 1 INTRODUCTION

In April 2023, Yolo County approved the Zamora Pistachio Facility Project. Yolo County filed a California Environmental Quality Act (CEQA) Notice of Exemption (NOE) when it approved the project. The project is consistent with the *County of Yolo 2030 Countywide General Plan*, for which an environmental impact report (EIR) (Yolo County General Plan EIR) (Yolo County 2009a) was completed in 2009. The Yolo County Zoning Code is consistent with the General Plan. Per Yolo County Zoning Code Table 8-2.304(a)(2), regional-serving agricultural operations, including processing facilities, under 100,000 square feet (sq ft) and 60 truck trips per day, are allowed with the issuance of a Site Plan Review in Agricultural Intensive (A-N) zones provided that the project meets development standards. Yolo County determined that the project would meet development standards and issued the Site Plan Review and NOE, copies of which are included in Appendix A. Following the County's determination, the applicant has initiated construction of the project.

The project approval includes a wastewater treatment facility (WWTF) that would be designed to treat and dispose of up to 50 million gallons per year (mgy) of treated effluent from the processing of pistachios. As with the rest of the project, the construction of the WWTF has been approved and is underway. In order for the project to become fully operational, the Central Valley Regional Water Quality Control Board (Regional Board) must issue Waste Discharge Requirements (WDRs) to operate the WWTF. The issuance of WDRs for wastewater discharge is the project analyzed in this Addendum.

This document has been prepared to satisfy CEQA (Public Resources Code [PRC] Section 21000 et seq.) and the State CEQA Guidelines (14 California Code of Regulations [CCR] 15000 et seq.). CEQA requires that all state and local government agencies consider the environmental consequences of projects over which they have discretionary authority before acting on those projects.

As a responsible agency, the Regional Board, in making its determinations and findings with regard to the project, must presume that Yolo County's Final EIR and approval of the facility in accordance therewith comport with the requirements of CEQA and are valid. (PRC Sections 21069, 21167.3; 14 CCR Section 15231; see *Yamaha Corp. of America v. State Bd. of Equalization* (1998) 19 Cal.4th 1, 12-13.) Pursuant to PRC Section 21083.3 and State CEQA Guidelines Section 15183, if a proposed development project is consistent with a general plan for which an EIR was certified, any further environmental review is limited to project-specific significant effects which are peculiar to the project or its site. PRC Section 21166 and CEQA Guidelines Sections 15162 through 15164 set forth the criteria for determining the appropriate additional environmental documentation, if any, to be completed when an EIR has been previously certified for the project for which a subsequent discretionary action is required.

This environmental checklist has been prepared to determine whether any additional environmental review is required for the Regional Board to find the Project (see Chapter 2, "Project Description") would result in any significant effects that were not addressed in the Yolo County General Plan EIR (Yolo County 2009a). The Regional Board also previously prepared the *Central Valley Salt and Nitrate Management Plan Substitute Environmental Documentation* (SED) (Regional Board 2016), which addresses salt and nitrate management in discharges from WWTFs. The WDRs incorporate requirements and conditions consistent with those analyzed in the SED. Therefore, in addition to the General Plan EIR, this assessment also considers if the WDRs would result in any environmental impacts that were not addressed in the SED (see Section 2.5, "Previous Environmental Documents").

The checklist analysis concludes that the criteria for subsequent environmental review specified in Section 15162 are not present for this project. The analysis therefore acts as an Addendum to the Previous Environmental Documents pursuant to Section 15164.

This page intentionally left blank.



## 2 PROJECT DESCRIPTION

As noted previously, Yolo County has approved the project and Zamora Pistachio (project applicant) has initiated construction. This chapter describes the approved project, including the wastewater treatment facility, to provide context for the Regional Board's pending action—consideration of issuance of Waste Discharge Requirements (WDRs).

Zamora Pistachio proposes to operate a new pistachio hulling and processing facility in the unincorporated community of Zamora in Yolo County, California. The project site consists of a total of approximately 480 acres; of which approximately 40 acres would be developed, and 440 acres would be used as a land application area (LAA). The 440 acres are currently planted with pistachio trees and have been since 2022. The new facility will not exceed a building area of 64,492 sq ft and will not generate more than 60 truck trips per day. Once constructed, the facility will operate year-round and would process pistachios during the harvest operations in August, September, and October.

The project's land uses are consistent with the Yolo County General Plan adopted by the County in November 2009, for which an EIR was certified (Yolo County General Plan EIR; State Clearinghouse No. 2008102034). The Yolo County General Plan guides land use decisions in the County. Zoning, specific plans, area plans, subdivisions, capital improvements, development agreements and many other land use actions must be consistent with the General Plan.

### 2.1 PROJECT LOCATION

The project site is located in the unincorporated community of Zamora, in northern Yolo County. Zamora is located along Interstate 5 (I-5), approximately 9 miles west of Knights Landing and approximately 30 miles northwest of Sacramento. The project site is located on Accessor's Parcel Number 055-150-005 and is bounded by County Road 13 to the north, County Road 96 to the east, County Road 14 to the south, and County Road 95 to the west (Figure 2-1). The 40 acres of the site that is being developed are located at the corner of County Road 13 and County Road 95. Neighboring land uses include agriculture and I-5.

The project site slopes gently to the north-northeast with a slope of 20 to 40 feet per mile at elevations ranging from approximately 40 to 70 feet above mean sea level. Surface water drains to the Colusa Basin Drainage Canal located approximately 3 miles to the northeast.

The Yolo County General Plan designates the project site as Agricultural (AG) and it is zoned Agricultural Intensive (A-N). Adjacent properties are zoned A-N. The project site is under a Williamson Act Contract and is in Agricultural Preserve No. 003.

### 2.2 PROJECT OBJECTIVES

The overarching principles of the Yolo County General Plan, as described in the Draft EIR (Yolo County 2009b: 58), are:

- ▶ successful agriculture,
- ▶ protected open space and natural areas,
- ▶ distinct communities,
- ▶ safe and healthy communities,
- ▶ varied transportation alternatives,
- ▶ enhanced information and communication technology,
- ▶ strong and sustainable economy,
- ▶ abundant and clean water supply, and
- ▶ reduction of greenhouse gases and adaptation to climate change.

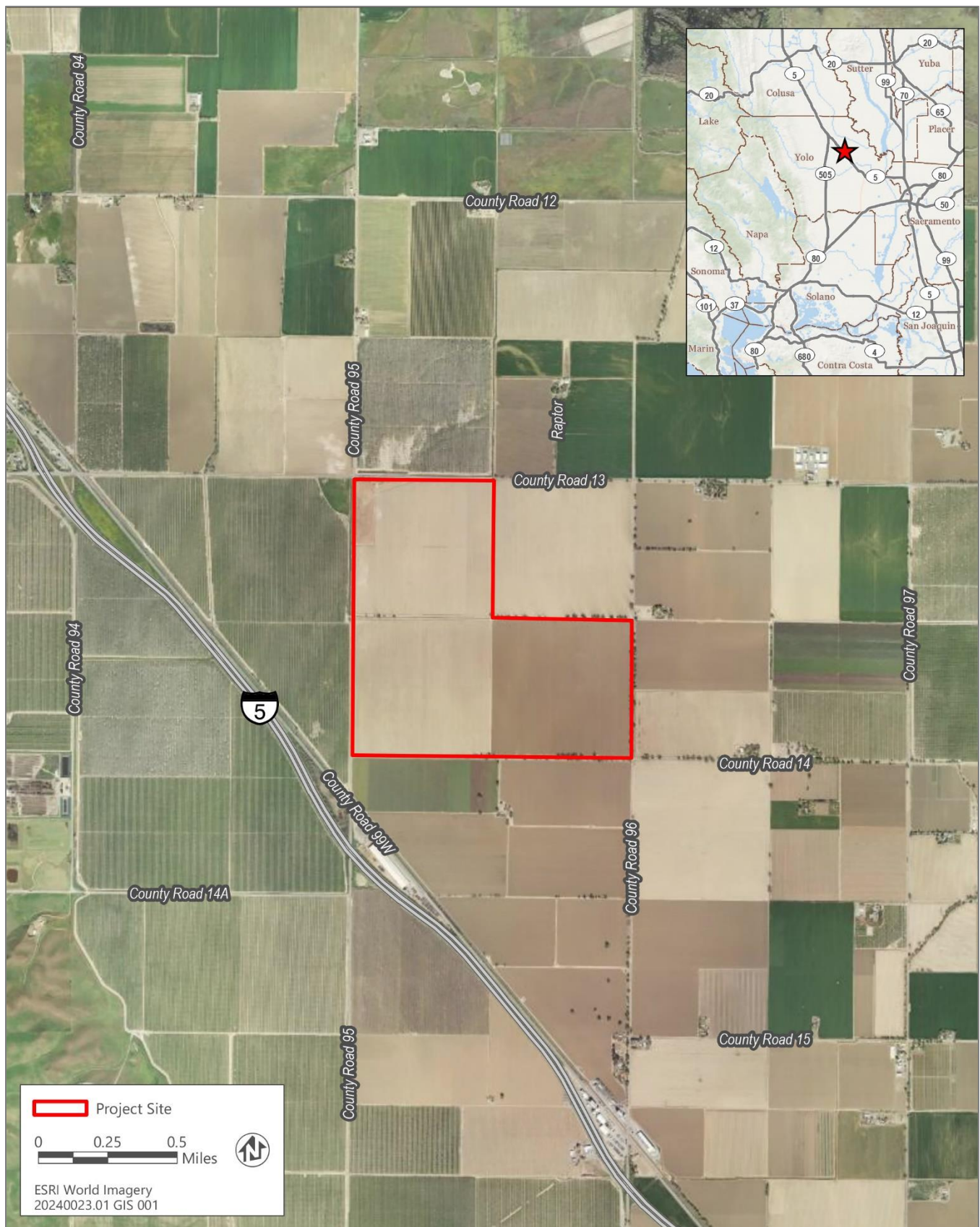

Source: Adapted by Ascent Environmental in 2024.

Figure 2-1 Project Location

The objectives of the Zamora Pistachio project are described below:

- ▶ implement an agricultural operation that is consistent with the Yolo County General Plan, which designates the project site for agricultural use;
- ▶ develop a high-quality agricultural operation that is consistent with the vision and design standards of the Agricultural (AG) land use designation, as envisioned in the Yolo County General Plan;
- ▶ meet the growing demand for agricultural processing of pistachios in Yolo County;
- ▶ support local job growth and employment opportunities;
- ▶ utilize the existing infrastructure and roadways and minimize growth-inducing effects; and
- ▶ comply with the waste discharge requirements of the Regional Board.

## 2.3 PROJECT ELEMENTS

Zamora Pistachio is constructing and will operate a new pistachio hulling and processing facility in the unincorporated community of Zamora in Yolo County, California. The facility will not exceed a building area of 64,492 sq ft and will not generate more than 60 truck trips per day.

Pistachios, like other nuts, are the seeds of fruits grown on pistachio trees. The nuts take about seven years to mature after a tree is planted. When the pistachios are ripe, harvesters use machines to shake the trees and allow the nuts to fall. They are then gathered and delivered to hulling and processing facilities. The key pistachio processing activities include hulling, drying, storage and fumigation (dry process), and roasting and pasteurization.

### 2.3.1 Proposed Pistachio Hulling and Processing Facility

The new facility is being constructed on 40 acres of the project site, at the corner of County Road 13 and County Road 95 (Figure 2-2). The new facility will provide 50,000 sq ft of packaging and production space for pistachio manufacturing and processing, while the remaining 14,492 sq ft will be for accessory buildings such as maintenance, scale house, break room, and storage. The processing building will include pistachio sizing machinery, and pin-pickers to separate naturally opened pistachios from closed ones, dry roasters, sorting machinery, fully automated packaging lines, flavoring production lines, salt brining systems, dozens of metal detection systems, and vacuum-packaging.

About 2,000 tons of pistachios are anticipated to be processed in 2024. Each year thereafter, Zamora Pistachio would increase production and processing by approximately 10 percent, with maximum operations expected in 2033. At full buildout, the facility would have a design capacity to accommodate the processing of 42,000 tons of pistachios per year. The amount processed in any given year would depend on the pistachio harvest. Pistachio trees are alternate bearing, meaning the harvest is heavier in alternate years.

## HARVEST PROCESS AND WASTEWATER

Pistachios will be harvested from the fields and delivered to the processing area. Then the nuts will be routed through a pre-cleaning stage served by cyclones to remove small twigs, leaves, and trash. Next, the nuts will be hulled, washed, and rinsed in float tanks. After rinsing, the nuts will be dried in natural gas-fired column dryers to reduce moisture, and then will be transferred to large silos for further drying, storage, and fumigation. Industrial wastewater generated in the hulling and washing process will be temporarily stored in a wastewater pond after filtration and treatment of the hulling wastewater prior to land application. Wastewater generated from the pasteurization process is expected to be minimal (approximately two gallons per day) and will be discharged directly into the facility's subsurface irrigation system. A process flow chart illustrating the steps in the treatment and discharge of the pistachio hulling wastewater is provided in Figure 2-3.

This page intentionally left blank.

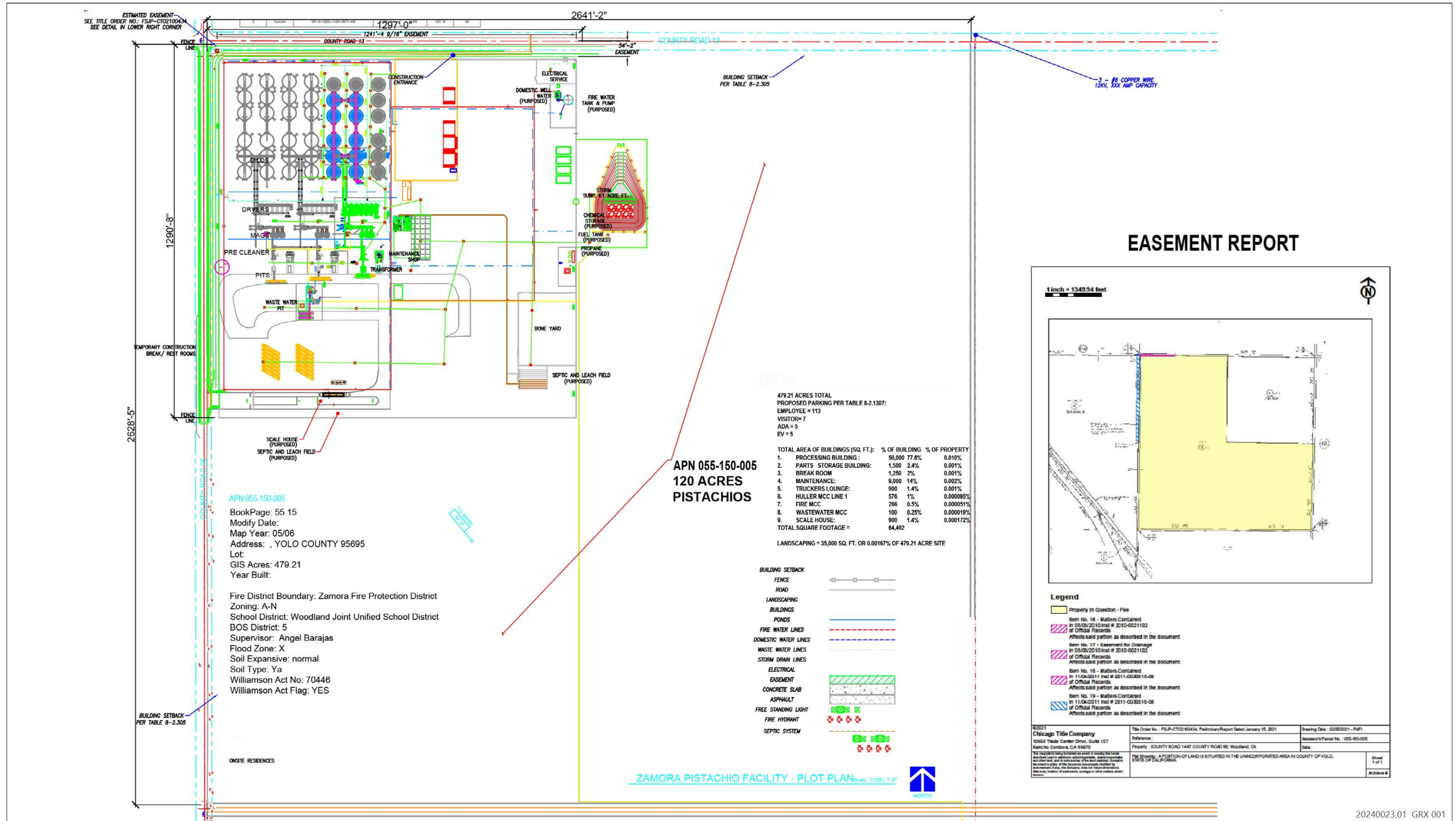

Source: Provided by Zamora Pistachio in 2024.

Figure 2-2 Project Site Plan



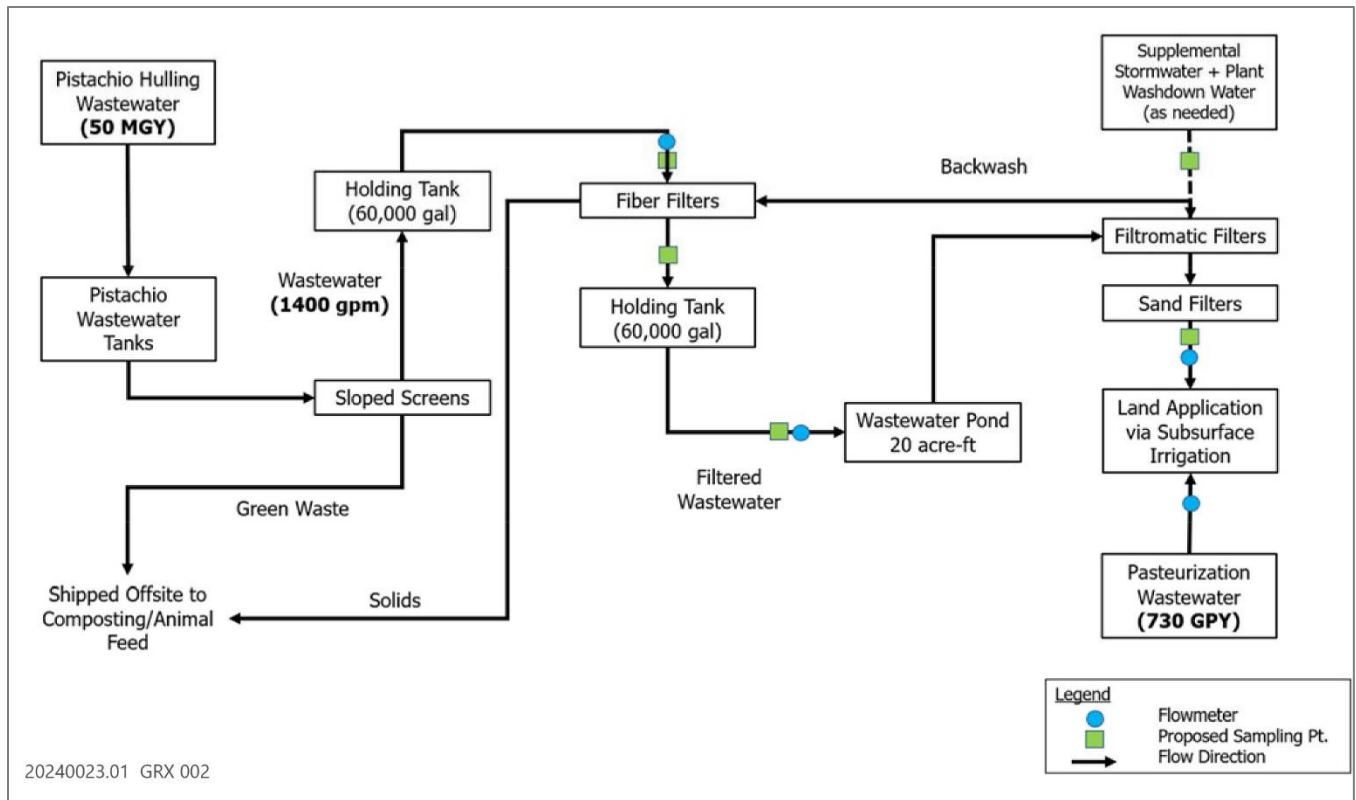

Source: Provided by Zamora Pistachio in 2024.

Figure 2-3 Harvest Wastewater Flowchart

### WASTEWATER DISCHARGE LIMIT

The facility would discharge approximately 5 mgy beginning in 2024. Each year thereafter, Zamora Pistachio would increase production and processing by approximately 10 percent, with full capacity production expected in 2033 and an ultimate discharge limit of 50 mgy (Table 2-1).

**Table 2-1 Projected Wastewater Flows per Year**

Year	Annual Flows (mgy)
2024	5
2025	10
2026	15
2027	20
2028	25
2029	30
2030	35
2031	40
2032	45
2033+	50

Source: Zamora Pistachio 2023.

Zamora Pistachio is requesting authorization from the Regional Board to discharge up to 50 mg of pistachio process wastewater flow at full operations. The majority of the process water flow would consist of hulling wastewater, with smaller contributions from roasting and pasteurization. The maximum daily flow would be 2 million gallons (mg) based on the fiber filtration rate of 1,400 gallons per minute (gpm) and 24 hours per day operation.

This wastewater would be filtered, as described below, and utilized for irrigation of 440 acres of agricultural lands (LAAs).

## FILTRATION

Various filtration systems would be used to remove solids from all wastewater streams, including a fiber filter system. Pre-treated wastewater, using narrower wedge-wire screens would feed into the fiber filter system at 1,400 gpm. The fiber filter would operate continuously with a fabric filter that would be vibrated clean by the process flow, requiring only occasional back-flush cycles. The fiber filter would remove solids up to 200 microns. The second set of filters would be 150-micron size. The treated water from this process will then be pumped to the wastewater pond where it will be filtered again and then discharged by subsurface irrigation to the land application areas.

The screened solids would be collected and trucked by a licensed transportation company to a composting facility or to a similar facility and/or to an animal feed company.

## AERATION

Aeration provides dissolved oxygen (DO) to the wastewater to support the biological and chemical oxidation of any odorous compounds and any precursors of odorous compounds. Surface aeration would be used in the irrigation pond to treat the water as this type generally creates the maximum possible mixing and a high level of oxygen transfer.

## LAND APPLICATION AREAS

LAAs are agricultural lands that are authorized by the Regional Board to receive treated wastewater from wastewater treatment facilities for irrigation purposes. Land application of the treated and filtered wastewater would occur via subsurface irrigation on the LAAs. Before entering the subsurface irrigation system, the wastewater would be filtered again (third filtration system) through sand filters to remove the finer solids to a size suitable for high-efficiency drip irrigation. As noted above, approximately 440 acres LAAs are proposed.

## SOLID WASTE

At buildout, the facility is expected to generate approximately 14,000 tons of agricultural hull bio-matter annually, a portion of which would be composted and hauled off to composting and cattle feed locations outside of the project site.

## TRUCK TRIPS

The facility would not generate more than 60 truck trips per day, which would include pistachio deliveries, delivery of "finished" products, and off-hauling of waste solids to composting and cattle feed locations.

## ENERGY

The Pacific Gas and Electric Company (PG&E), which supplies most of Yolo County with electricity and natural gas, will supply the project's electrical demands. As part of the project, Zamora Pistachio has applied for and obtained Authority to Construct permits from the Yolo-Solano Air Quality Management District (YSAQMD).



## ODOR CONTROL

Odors from the pistachio processing and wastewater discharge will be controlled through the use of chemical oxidizer and pH control chemicals, such as hydrogen peroxide and pond aeration. An odor control plan will be prepared for the facility.

## STAFFING

At build-out, the facility will employ 100-130 employees for 6 weeks, during peak harvest operations in (August through October), operating 24 hours per day, 7 days per week. Outside of the harvest season (November through July), the facility will employ 30-35 employees.

## PHASING

The facility will be installed in two phases. Phase 1 will consist of installing silos, dryers, and associated equipment with a scale house, breakroom, maintenance building, and compressed natural gas tanks. The facility will be accessed from County Road 95. The tree nut and shelling operation will initially employ 25 employees during the harvesting operations (6 weeks) and 8 full-time employees for the balance of the year.

Phase Two will consist of installing the processing building, employee/visitor parking with solar shade structures, landscaping, a truckers break room, and an expanded maintenance building attached to the existing break room. A gas line will be extended to the facility and the aboveground compressed natural gas (CNG) tanks will be removed.

The completed facility will consist of 42 silos, dryers, peelers, per-cleaners, receiving pits, scale house, maintenance room, break room, truckers break room, parts storage area, processing building, solar carports, and storm and wastewater ponds.

The facility is expected to be operational in the third quarter of 2024.

### 2.3.2 Construction

As noted previously, project construction is underway and will be completed in 2024.

## 2.4 POTENTIAL PERMITS AND APPROVALS REQUIRED

The following is a list of approvals and/or permits that may be required to implement the project.

### 2.4.1 State

- ▶ Central Valley Regional Water Quality Control Board: review and approval of Report of Waste Discharge, and
- ▶ National Pollutant Discharge Elimination System: construction stormwater permit if more than one acre of soil is disturbed (Notice of Intent to proceed under General Construction Permit) [permit already issued].

### 2.4.2 Local

- ▶ Yolo County: ongoing permits (e.g., building and encroachment permits) to be issued for Phase Two of the project.
- ▶ Yolo-Solano Air Quality Management District: air quality operating permits for the operation of various process units (e.g., heaters, dryers, storage silos, etc.) at the facility [permit already issued].

## 2.5 PREVIOUS ENVIRONMENTAL DOCUMENTS

Yolo County completed a comprehensive environmental review process and certified the Yolo County General Plan EIR in 2009. The process involved the preparation of a series of environmental documents, listed below.

- ▶ Draft EIR for the Yolo County General Plan
- ▶ Final EIR for the Yolo County General Plan
- ▶ Mitigation Monitoring and Reporting Plan for the Yolo County General Plan
- ▶ Findings of Fact and Statement of Overriding Considerations for the Yolo County General Plan

For purposes of this checklist, the above documents are collectively referred to as Yolo County General Plan EIR.

In December 2016, the Regional Board prepared substitute environmental documentation (SED) in support of the Central Valley Salt and Nitrate Management Plan. The facility's discharge will be managed consistent with the requirements and conditions of that Plan, as incorporated into the WDRs.

### 3 EVALUATION OF ENVIRONMENTAL IMPACTS

CEQA Guidelines Sections 15162 through 15164 set forth the criteria for determining the appropriate level of additional environmental documentation, if any, to be completed when there is a previously certified EIR for the project for which a subsequent discretionary action is required. This checklist has been prepared to assist the Regional Board in determining whether any additional environmental documentation is needed for the subject discretionary action.

As described in Chapters 1 and 2, the overall project has already been approved and is under construction, including the wastewater treatment facility (WWTF). Yolo County has already determined that the project is consistent with the Yolo County General Plan, is exempt from any additional CEQA analysis, and has approved the project. The only pending approval is issuance of Waste Discharge Requirements from the Regional Board. That approval is achieved through the issuance of WDRs that incorporate requirements and conditions previously identified by the Central Valley Water Board in its environmental analysis of the Central Valley Salt and Nitrate Management Plan.

The purpose of this checklist is to evaluate the environmental resource categories in terms of any “changed condition” (i.e., changed circumstances, project changes, or new information of substantial importance) that may result in environmental impact significance conclusions different from those found in the previously certified EIRs. The row titles of the checklist include the full range of environmental topics, as presented in Appendix G of the State CEQA Guidelines. The column titles of the checklist have been modified from the Appendix G presentation to help answer the questions to be addressed pursuant to Public Resources Code Section 21083.3 and 21166 and State CEQA Guidelines Section 15162 to 15164, and 15183. A “no” answer does not necessarily mean that there are no potential impacts relative to the environmental category, but that there is no change in the condition or status of the impact as it was analyzed and addressed in the previously certified *County of Yolo 2030 Countywide General Plan EIR* (Yolo County General Plan EIR) (Yolo County 2009a) or, as it relates to hydrology/water quality, the *Central Valley Salt and Nitrate Management Plan Substitute Environmental Documentation* (SED) (Regional Board 2016). The purpose of each column of the checklist is described below. In addition, the checklist tables in each section are followed by a summary of the Yolo County General Plan EIR (or SED for hydrology/water quality) analysis of that environmental topic. (It should be noted that, given the scale of cumulative development in the region, a project that is consistent with the Yolo County General Plan would be within the scope of the EIR’s cumulative analysis; therefore, the cumulative impacts identified in the Yolo County General Plan EIR are not individually summarized.) Following the summary of the Yolo County General Plan EIR (as well as the SED for hydrology/water quality) analysis is the consistency evaluation, which describes how the project’s potential impacts compare to the impacts evaluated in the Yolo County General Plan EIR or SED.

Note that, because the project was exempted from CEQA and approved by Yolo County, the analysis included herein is relatively brief, except the impacts related to hydrology/water quality. Because any impacts peculiar to the project are related to adoption of the WDRs for the wastewater discharge, the hydrology/water quality section analyzes those impacts more thoroughly. The checklist includes the following questions:

#### **Where were impacts analyzed previously?**

This column provides a cross-reference to the pages of the Yolo County General Plan EIR (as well as the SED for hydrology/water quality) where information and analysis are found relative to the environmental issue listed under each topic.

#### **Do proposed changes, new circumstances, or new information result in new significant/substantially more severe impacts?**

Pursuant to CEQA Guidelines Section 15162, subsections (a)(1) and (a)(2), this column indicates whether there are substantial changes in the project or circumstances or whether previously identified significant effects which, as a result of substantial changes or new information which was not known at the time the EIR was certified, are determined to have a more severe adverse impact than discussed in the prior EIR. A “yes” answer will be followed by

an indication of whether the impact is “potentially significant,” “less than significant with mitigation incorporated,” or “less than significant.” An analysis of the determination will appear in the Discussion section following the checklist.

### **Is there substantial new information requiring new analysis or verification?**

Pursuant to CEQA Guidelines Section 15162, subsections (a)(3)(A-D), this column indicates whether new information of substantial importance, which was not known and could not have been known with the exercise of reasonable diligence at the time the previous EIR was certified as complete, shows any of the following:

- i. The project will have one or more significant effects not discussed in the previous EIR.
- ii. Significant effects previously examined will be substantially more severe than shown in the previous EIR.
- iii. Mitigation measures or alternatives previously found not to be feasible would in fact be feasible, and would substantially reduce one or more significant effects of the project, but the project proponents decline to adopt the mitigation measure or alternative.
- iv. Mitigation measures or alternatives which are considerably different from those analyzed in the previous EIR, and would substantially reduce one or more significant effects on the environment, but the project proponents decline to adopt the mitigation measure or alternative.

### **Do mitigation measures from prior documents resolve significant impacts?**

This column indicates whether the prior environmental document and/or the findings adopted by the lead agency decision-making body provides mitigation measures to address effects in the related impact category. A “yes” response will be provided if previously adopted mitigation would mitigate the impact to less than significant. If the impact would remain significant and unavoidable after implementation of previously adopted mitigation, the column will indicate “yes, but impact remains significant and unavoidable.” If “NA” is indicated, this Environmental Review concludes that the impact does not occur with this project and, therefore, no mitigation measures are needed.

# I. AESTHETICS

Environmental Issue	Where were impacts analyzed previously?	Do proposed changes/ new circumstances/ new information result in new significant/ substantially more severe impacts?	Is there substantial new information requiring new analysis or verification?	Do mitigation measures from prior documents resolve significant impacts?
Except as provided in Public Resources Code section 21099 (where aesthetic impacts shall not be considered significant for qualifying residential, mixed-use residential, and employment centers), would the project:				
a) Have a substantial adverse effect on a scenic vista?	DEIR pages 752-754	No	No	N/A
b) Substantially damage scenic resources, including, but not limited to, trees, rock outcroppings, and historic buildings within a state scenic highway?	DEIR pages 754-755	No	No	N/A
c) In non-urbanized areas, substantially degrade the existing visual character or quality of public views of the site and its surroundings? (Public views are those that are experienced from publicly accessible vantage points.) If the project is in an urbanized area, would the project conflict with applicable zoning and other regulations governing scenic quality?	DEIR Impact VIS-1	No	No	N/A
d) Create a new source of substantial light or glare which would adversely affect day or nighttime views in the area?	DEIR Impact VIS-2	No	No	N/A

## SUMMARY OF EIR ANALYSIS

Impacts from implementation of the Yolo County General Plan are evaluated in the Yolo County General Plan Draft EIR in Chapter IV, Section N, "Visual and Scenic Resources," and are listed below.

- ▶ Block a Unique or Locally-Significant View. This impact would be less than significant.
- ▶ Impacts to Scenic Corridors. This impact would be less than significant.
- ▶ Degrade Visual Character and Quality of the County. Impact VIS-1: Build-out of the Draft General Plan would result in new growth that degrades the existing visual character and quality of the County. Even with mitigation, this impact would be significant and unavoidable.
- ▶ Create New Light and Glare. Impact VIS-2: Implementation of the Draft General Plan could result in additional uses that would create new sources of substantial light or glare, which could adversely affect nighttime views outside of identified growth areas. Even with mitigation, this impact would be significant and unavoidable.
- ▶ Conflict with Plans and Policies of Other Agencies. This impact would be less than significant.
- ▶ Result in Adverse Impacts from Draft General Plan Policies Compared to 1983 General Plan Policies. This impact would be less than significant.

## CONSISTENCY EVALUATION

Yolo County approved the project through the issuance of a Site Plan Review and Notice of Exemption (NOE), copies of which are included in Appendix A. The Site Plan Review issued for the project identifies the following standard requirements related to aesthetics, which are being implemented by the applicant:

- ▶ Prior to installation of any signage, the operator and/or owner of the facility shall contact Yolo County Planning to go over permit requirements in the County's Sign Ordinance regulating the placement, size, and height of such signs.
- ▶ Outdoor light fixtures shall be low intensity, shielded, and/or directed away from adjacent properties, the public right-of-way and the night sky. A lighting plan including light fixture details, pole height, and a photometric plan to one lumen isolines shall be submitted for review prior to approval of the building permit.

Because the project was determined to be consistent with the General Plan, including its land use element, project-related effects related to aesthetics would be consistent with and were covered by the analysis and conclusions of the Yolo County General Plan EIR. No element of the project would change the conclusions of the Yolo County General Plan EIR or result in new or substantially more severe impacts, and no additional environmental review is needed for the project related to aesthetics.

## II. AGRICULTURAL AND FOREST RESOURCES

Environmental Issue	Where were impacts analyzed previously?	Do proposed changes/new circumstances/new information result in new significant/substantially more severe impacts?	Is there substantial new information requiring new analysis or verification?	Do mitigation measures from prior documents resolve significant impacts?
<p>In determining whether impacts to agricultural resources are significant environmental effects, lead agencies may refer to the California Agricultural Land Evaluation and Site Assessment Model (1997, as updated) prepared by the California Department of Conservation as an optional model to use in assessing impacts on agriculture and farmland.</p>				
<p>In determining whether impacts to forest resources, including timberland, are significant environmental effects, lead agencies may refer to information compiled by the California Department of Forestry and Fire Protection regarding the state’s inventory of forest land, including the Forest and Range Assessment Project and the Forest Legacy Assessment project; and forest carbon measurement methodology provided in Forest Protocols adopted by the California Air Resources Board.</p>				
<p>Would the project:</p>				
<p>a) Convert Prime Farmland, Unique Farmland, or Farmland of Statewide Importance (Farmland), as shown on the maps prepared pursuant to the Farmland Mapping and Monitoring Program of the California Resources Agency, to non-agricultural use?</p>	DEIR Impact AG-1	No	No	N/A
<p>b) Conflict with existing zoning for agricultural use or a Williamson Act contract?</p>	DEIR Impact AG-2	No	No	N/A
<p>c) Conflict with existing zoning for, or cause rezoning of, forest land (as defined in Public Resources Code section 12220(g)), timberland (as defined by Public Resources Code section 4526), or timberland zoned Timberland Production (as defined by Government Code section 51104(g))?</p>	Not evaluated	No	No	N/A
<p>d) Result in the loss of forest land or conversion of forest land to non-forest use?</p>	Not evaluated	No	No	N/A
<p>e) Involve other changes in the existing environment, which, due to their location or nature, could result in conversion of Farmland to non-agricultural use or conversion of forest land to non-forest use?</p>	DEIR Impact AG-1	No	No	N/A

### SUMMARY OF EIR ANALYSIS

Impacts from implementation of the Yolo County General Plan are evaluated in the Yolo County General Plan Draft EIR in Chapter IV, Section B, “Agricultural Resources,” and are listed below.

- ▶ Convert Prime Farmland, Unique Farmland, or Farmland of Statewide Importance. Impact AG-1: Build-out of the Draft General Plan and the associated development would convert Prime Farmland, Unique Farmland, or Farmland of Statewide Importance to non-agricultural uses. No feasible mitigation is available, and this impact would be significant and unavoidable.

- ▶ Conflicts with Williamson Act contracts. Impact AG-2: Build-out of the Draft General Plan and the associated development would conflict with or result in the cancellation of a Williamson Act contract. Even with mitigation, this impact would be significant and unavoidable.
- ▶ Permanent Conversion of Agricultural Soils. Impact AG-3: Build-out of the Draft General Plan and the associated development would result in permanent conversion of agricultural soils to non-agricultural use. No feasible mitigation is available, and this impact would be significant and unavoidable.
- ▶ Loss of Agricultural Productivity or Crop Values. This impact would be less than significant.
- ▶ Conflict with Plans and Policies of Other Agencies. This impact would be less than significant.
- ▶ Result in Adverse Impacts from Draft General Plan Policies Compared to 1983 General Plan Policies. This impact would be less than significant.
- ▶ Impact AG-4: Implementation of Draft General Plan policies could result in less effective buffers to protect agricultural operations. This impact would be less than significant after mitigation.

## CONSISTENCY EVALUATION

Yolo County approved the project through the issuance of a Site Plan Review and NOE, copies of which are included in Appendix A. Because the project was determined to be consistent with the General Plan, including its land use element, project-related effects related to agricultural and forest resources would be consistent with and were covered by the analysis and conclusions of the Yolo County General Plan EIR. The project would reinforce the designated use of the project site for agriculture. No element of the project would change the conclusions of the Yolo County General Plan EIR or result in new or substantially more severe impacts, and no additional environmental review is needed for the project related to agricultural and forest resources.



### III. AIR QUALITY

Environmental Issue	Where were impacts analyzed previously?	Do proposed changes/ new circumstances/ new information result in new significant/ substantially more severe impacts?	Is there substantial new information requiring new analysis or verification?	Do mitigation measures from prior documents resolve significant impacts?
Would the Project:				
Where available, the significance criteria established by the applicable air quality management district or air pollution control district may be relied on to make the following determinations.				
Are significance criteria established by the applicable air district available to rely on for significance determinations?				
a) Conflict with or obstruct implementation of the applicable air quality plan?	DEIR Impact AIR-1, AIR-2, AIR-5	No	No	N/A
b) Result in a cumulatively considerable net increase of any criteria pollutant for which the project region is non-attainment under an applicable federal or state ambient air quality standard?	DEIR Impact AIR-4	No	No	N/A
c) Expose sensitive receptors to substantial pollutant concentrations?	DEIR Impact AIR-3	No	No	N/A
d) Result in other emissions (such as those leading to odors) adversely affecting a substantial number of people?	DEIR pages 301-302	No	No	N/A

### SUMMARY OF EIR ANALYSIS

Impacts from implementation of the Yolo County General Plan are evaluated in the Yolo County General Plan Draft EIR in Chapter IV, Section D, "Air Quality," and are listed below.

- ▶ Violate Applicable Air Quality Standards. Impact AIR-1: Build-out of the Draft General Plan could result in construction-related emissions that exceed the YSAQMD thresholds of significance for criteria pollutants. Even with mitigation, this impact would be significant and unavoidable.
- ▶ Exceed Carbon Monoxide, Reactive Organic Gases, or Nitrogen Oxide Thresholds. Impact AIR-2: Build-out of the Draft General Plan could result in long-term operational emissions that would exceed YSAQMD thresholds of significance and substantially contribute to air quality violations. Even with mitigation, this impact would be significant and unavoidable.
- ▶ Expose Humans to Toxic Air Contaminants. Impact AIR-3: Build-out of the Draft General Plan could expose sensitive receptors to toxic air contaminants. This impact would be less than significant after mitigation.
- ▶ Create Objectionable Odors. This impact would be less than significant.
- ▶ Result in Cumulative Impacts. Impact AIR-4: Build-out of the Draft General Plan could result in a cumulatively considerable impact on criteria air pollutants. No feasible mitigation is available, and this impact would be significant and unavoidable.

- ▶ Conflict with Plans or Policies of Other Agencies. Impact AIR-5: Build-out of the Draft General Plan could result in conflicts with air quality planning efforts by other agencies. This impact would be less than significant after mitigation.
- ▶ Result in Adverse Impacts from Draft General Plan Policies Compared to 1983 General Plan Policies. This impact would be less than significant.

## CONSISTENCY EVALUATION

Yolo County approved the project through the issuance of a Site Plan Review and NOE, copies of which are included in Appendix A. The Site Plan Review issued for the project identifies the following standard requirements related to air quality, which are being implemented by the applicant:

- ▶ Please be aware that this type of operation will require Yolo-Solano Air Quality Management District (District) permits, including Authority to Construct (ATCs) and Permits to Operate (PTOs). Once the applicant knows what equipment they plan to install, they should contact our engineering manager Ben Beattie to schedule a Zoom meeting to discuss permitting requirements. This should be done in advance of them purchasing any actual equipment.
- ▶ Any contractors and subcontractors must know about the requirement that all non-road (portable) engines, over 50 hp must be permitted with the Yolo-Solano Air Quality Management District in accordance with District Rule 3.1. In lieu of obtaining local District permit(s), the equipment can operate under a voluntary Portable Equipment Registration Program (PERP) administered by the Air Resources Board (ARB) so long as the equipment complies with the PERP conditions. These non-road engines are ones that don't provide propulsion, such as tow behind generators, compressors, or pumps and also auxiliary mounted 2nd engines. For more information, see <https://www.ysaqmd.org/permits/perp/>.
- ▶ The applicant should be aware of District prohibitory rules that may apply, including but not limited to Rule 2.3 for visible emissions (<https://www.ysaqmd.org/wpcontent/uploads/2020/05/2.3.pdf>), Rule 2.5 for nuisance (<https://www.ysaqmd.org/wpcontent/uploads/2020/05/2.5.pdf>), and Rule 2.14 for architectural coatings (<https://www.ysaqmd.org/wp-content/uploads/2020/05/2.14.pdf>).

Because the project was determined to be consistent with the General Plan, including its land use element, and because the project is required to procure ATCs and PTOs, which would further reduce potential emissions, project-related effects related to air quality would be consistent with and were covered by the analysis and conclusions of the Yolo County General Plan EIR. No element of the project would change the conclusions of the Yolo County General Plan EIR or result in new or substantially more severe impacts, and no additional environmental review is needed for the project related to air quality.

## IV. BIOLOGICAL RESOURCES

Environmental Issue	Where were impacts analyzed previously?	Do proposed changes/ new circumstances/ new information result in new significant/ substantially more severe impacts?	Is there substantial new information requiring new analysis or verification?	Do mitigation measures from prior documents resolve significant impacts?
Would the Project:				
a) Have a substantial adverse effect, either directly or through habitat modifications, on any species identified as a candidate, sensitive, or special-status species in local or regional plans, policies, or regulations, or by the California Department of Fish and Wildlife or the U.S. Fish and Wildlife Service?	DEIR Impacts BIO-1 through BIO-3, Impact BIO-5, and Impact BIO-6	No	No	N/A
b) Have a substantial adverse effect on any riparian habitat or other sensitive natural community identified in local or regional plans, policies, or regulations or by the California Department of Fish and Wildlife or the U.S. Fish and Wildlife Service?	DEIR Impact BIO-1	No	No	N/A
c) Have a substantial adverse effect on state or federally protected wetlands (including, but not limited to, marsh, vernal pool, coastal, etc.) through direct removal, filling, hydrological interruption, or other means?	DEIR Impact BIO-2	No	No	N/A
d) Interfere substantially with the movement of any native resident or migratory fish or wildlife species or with established native resident or migratory wildlife corridors, or impede the use of native wildlife nursery sites?	DEIR Impact BIO-4	No	No	N/A
e) Conflict with any local policies or ordinances protecting biological resources, such as a tree preservation policy or ordinance?	DEIR page 633	No	No	N/A
f) Conflict with the provisions of an adopted Habitat Conservation Plan, Natural Community Conservation Plan, or other approved local, regional, or state habitat conservation plan?	DEIR page 633	No	No	N/A

## SUMMARY OF EIR ANALYSIS

Impacts from implementation of the Yolo County General Plan are evaluated in the Yolo County General Plan Draft EIR in Chapter IV, Section J, "Biological Resources," and are listed below.

- ▶ Adverse Effect on Riparian Habitats. Impact BIO-1: Build-out of the Draft General Plan may result in loss or destruction of riparian habitats and the wildlife and plants that depend on those habitats. Even with mitigation, this impact would be significant and unavoidable.
- ▶ Impacts to Wetlands and Vernal Pools. Impact BIO-2: Build-out of the Draft General Plan may result in loss or destruction of wetlands and vernal pools and the wildlife and plants that depend on those habitats. Even with mitigation, this impact would be significant and unavoidable.
- ▶ Impacts to Oak Woodlands. Impact BIO-3: Build-out of the Draft General Plan may result in loss or destruction of oak woodlands and the wildlife and plants that depend on those habitats. Even with mitigation, this impact would be significant and unavoidable.
- ▶ Impacts to Wildlife Movement Corridors or Nursery Sites. Impact BIO-4: Build-out of the Draft General Plan may result in the disruption of movement corridors and nursery sites on which local wildlife depend. Even with mitigation, this impact would be significant and unavoidable.
- ▶ Impacts to Special-Status Species. Impact BIO-5: Build-out of the Draft General Plan may result in the loss or destruction of special-status plants and their habitats, and/or to special-status fish and wildlife and their habitats. Even with mitigation, this impact would be significant and unavoidable.
- ▶ Reduce Wildlife Habitat. Impact BIO-6: Build-out of the Draft General Plan would result in a general loss of habitat in natural and agricultural areas. No feasible mitigation is available, and this impact would be significant and unavoidable.
- ▶ Conflict with Plans and Policies of Other Agencies. This impact would be less than significant.
- ▶ Result in Adverse Impacts from Draft General Plan Policies Compared to 1983 General Plan Policies. This impact would be less than significant.

## CONSISTENCY EVALUATION

Yolo County approved the project through the issuance of a Site Plan Review and NOE, copies of which are included in Appendix A. The Site Plan Review issued for the project identifies the following standard requirements related to biological resources, which are being implemented by the applicant:

- ▶ CalGreen/Shade Trees: Meet all CalGreen development requirements, including shade tree coverage minimum #10 container size shall be 50% of parking area and 20% of hardscape within 15 years. The landscape architect shall document the calculations and attest to this on the final landscape plan. Exemptions may be granted for solar shade structures.

Because the project was determined to be consistent with the General Plan, including its land use element, project-related effects related to biological resources would be consistent with and were covered by the analysis and conclusions of the Yolo County General Plan EIR. The project involves intensification of agricultural uses on a site dedicated to agriculture. No element of the project would change the conclusions of the Yolo County General Plan EIR or result in new or substantially more severe impacts, and no additional environmental review is needed for the project related to biological resources.

## V. CULTURAL RESOURCES

Environmental Issue	Where were impacts analyzed previously?	Do proposed changes/ new circumstances/ new information result in new significant/ substantially more severe impacts?	Is there substantial new information requiring new analysis or verification?	Do mitigation measures from prior documents resolve significant impacts?
Would the Project:				
a) Cause a substantial adverse change in the significance of a historical resource pursuant to Section 15064.5?	DEIR Impact CULT-1	No	No	N/A
b) Cause a substantial adverse change in the significance of an archaeological resource pursuant to Section 15064.5?	DEIR Impact CULT-2	No	No	N/A
c) Substantially disturb human remains, including those interred outside of formal cemeteries?	DEIR pages 547-548	No	No	N/A

### SUMMARY OF EIR ANALYSIS

Impacts from implementation of the Yolo County General Plan are evaluated in the Yolo County General Plan Draft EIR in Chapter IV, Section I, "Cultural Resources," and are listed below.

- ▶ Implementation of the Draft General Plan Could Cause a Substantial Adverse Change in the Significance of Historical Resources. Impact CULT-1: Build-out of the Draft General Plan would result in the potential for impacts to architectural resources and archaeological deposits that qualify as historical resources under CEQA. No feasible mitigation is available, and this impact would be significant and unavoidable.
- ▶ Implementation of the Draft General Plan Could Cause a Substantial Adverse Change in the Significance of Unique Archaeological Resource. Impact CULT-2: Build-out of the Draft General Plan would result in the potential for impacts to archaeological deposits that qualify as unique archaeological resources under CEQA. No feasible mitigation is available, and this impact would be significant and unavoidable.
- ▶ Implementation of the Draft General Plan Could Directly or Indirectly Destroy a Unique Paleontological Resource or Site. This impact would be less than significant.
- ▶ Implementation of the Draft General Plan Could Disturb Human Remains. This impact would be less than significant.
- ▶ Implementation of the Draft General Plan Could Cause a Substantial Adverse Change in Religious, Sacred, or Unique Ethnic-Cultural Sites or Resources. This impact would be less than significant.
- ▶ Implementation of the Draft General Plan Could Conflict with Plans or Policies of Other Agencies. This impact would be less than significant.
- ▶ Result in Significant Adverse Physical Impacts as Compared to the 1983 General Plan Policies. This impact would be less than significant.

## CONSISTENCY EVALUATION

Yolo County approved the project through the issuance of a Site Plan Review and NOE, copies of which are included in Appendix A. Because the project was determined to be consistent with the General Plan, including its land use element, project-related effects related to cultural resources would be consistent with and were covered by the analysis and conclusions of the Yolo County General Plan EIR. Moreover, if any cultural resources are encountered during construction, the applicant would be required to comply with Public Resources Code Section 15064.5(e), which addresses circumstances when such resources are accidentally uncovered. No element of the project would change the conclusions of the Yolo County General Plan EIR or result in new or substantially more severe impacts, and no additional environmental review is needed for the project related to cultural resources.

## VI. ENERGY

Since certification of the Yolo County General Plan EIR in 2009, Appendix G of the State CEQA Guidelines has been amended to address energy consumption and compliance with applicable renewable energy or energy efficiency plans. At the time the Yolo County General Plan Draft EIR was prepared and certified, energy efficiency related impacts were included as Appendix F to the State CEQA Guidelines. The Yolo County General Plan EIR did evaluate energy demand and the impacts related to it, but in the context of utilities and utility infrastructure.

Environmental Issue	Where were impacts analyzed previously?	Do proposed changes/ new circumstances/ new information result in new significant/ substantially more severe impacts?	Is there substantial new information requiring new analysis or verification?	Do mitigation measures from prior documents resolve significant impacts?
Would the Project:				
a) Result in potentially significant environmental impact due to wasteful, inefficient, or unnecessary consumption of energy resources, during project construction or operation?	DEIR pages 506-511	No	No	N/A
b) Conflict with or obstruct a state or local plan for renewable energy or energy efficiency?	DEIR pages 506-511	No	No	N/A

## SUMMARY OF EIR ANALYSIS

Impacts from implementation of the Yolo County General Plan are evaluated in the Yolo County General Plan Draft EIR in Chapter IV, Section H, "Utilities and Energy," and are listed below.

- ▶ Create Substantial Increase in Overall Consumption. The impact would be less than significant.
- ▶ Increase Demand in Excess of Planned Supplies or Distribution. This impact was too speculative to make a significance conclusion.
- ▶ Increase Reliance on Non-renewable Energy Resources. The impact would be less than significant.
- ▶ Use of Alternative Fuels, Renewable Energy Sources, and Energy Conservation. The impact would be less than significant.
- ▶ Inefficient, Wasteful, Or Unnecessary Use of Fuel. The impact would be less than significant.
- ▶ Fail To Result In Siting, Orientation, And/or Design To Minimize Energy Consumption. The impact would be less than significant.

## CONSISTENCY EVALUATION

Yolo County approved the project through the issuance of a Site Plan Review and NOE, copies of which are included in Appendix A. Because the project was determined to be consistent with the General Plan, including its land use element, project-related effects related to energy would be consistent with and were covered by the analysis and conclusions of the Yolo County General Plan EIR. No element of the project would change the conclusions of the Yolo County General Plan EIR or result in new or substantially more severe impacts, and no additional environmental review is needed for the project related to energy.

## VII. GEOLOGY AND SOILS

Environmental Issue	Where were impacts analyzed previously?	Do proposed changes/ new circumstances/ new information result in new significant/ substantially more severe impacts?	Is there substantial new information requiring new analysis or verification?	Do mitigation measures from prior documents resolve significant impacts?
Would the Project:				
a) Directly or indirectly cause potential substantial adverse effects, including the risk of loss, injury, or death involving:	DEIR pages 703-705	No	No	N/A
i) Rupture of a known earthquake fault, as delineated on the most recent Alquist-Priolo Earthquake Fault Zoning Map issued by the State Geologist for the area or based on other substantial evidence of a known fault? (Refer to California Geological Survey Special Publication 42.)	DEIR pages 703-705	No	No	N/A
ii) Strong seismic ground shaking?	DEIR pages 703-705	No	No	N/A
iii) Seismic-related ground failure, including liquefaction?	DEIR pages 703-705	No	No	N/A
iv) Landslides?	DEIR pages 703-705	No	No	N/A
b) Result in substantial soil erosion or the loss of topsoil?	DEIR page 705	No	No	N/A
c) Be located on a geologic unit or soil that is unstable, or that would become unstable as a result of the project, and potentially result in on- or off-site landslide, lateral spreading, subsidence, liquefaction, or collapse?	DEIR pages 703-705	No	No	N/A
d) Be located on expansive soil, as defined in Table 18-1-B of the Uniform Building Code (1994, as updated), creating substantial direct or indirect risks to life or property?	DEIR pages 703-705	No	No	N/A
e) Have soils incapable of adequately supporting the use of septic tanks or alternative waste water disposal systems where sewers are not available for the disposal of waste water?	DEIR pages 703-705	No	No	N/A
f) Directly or indirectly destroy a unique paleontological resource or site or unique geologic feature?	DEIR GEO-1	No	No	N/A



## SUMMARY OF EIR ANALYSIS

Impacts from implementation of the Yolo County General Plan are evaluated in the Yolo County General Plan Draft EIR in Chapter IV, Section L, "Geology, Soils, Seismicity, and Mineral Resources," and are listed below.

- ▶ Expose People or Structures to Substantial Risk Related to Geohazards. This impact would be less than significant.
- ▶ Result in Erosion or Loss of Topsoil Through the Alteration of Topography, Dewatering, or Changes in Drainage Patterns. This impact would be less than significant.
- ▶ Destruction or Modification of a Unique Geologic Feature. Impact GEO-1: Implementation of the Draft General Plan could result in the destruction or modification of a unique geologic feature. This impact would be less than significant after mitigation.
- ▶ Conflict with Plans and Policies of Other Agencies. This impact would be less than significant.
- ▶ Result in Adverse Impacts from Draft General Plan Policies Compared to 1983 General Plan Policies. This impact would be less than significant.

## CONSISTENCY EVALUATION

Yolo County approved the project through the issuance of a Site Plan Review and NOE, copies of which are included in Appendix A. Because the project was determined to be consistent with the General Plan, including its land use element, project-related effects related to geology and soils would be consistent with and were covered by the analysis and conclusions of the Yolo County General Plan EIR. No element of the project would change the conclusions of the Yolo County General Plan EIR or result in new or substantially more severe impacts, and no additional environmental review is needed for the project related to geology and soils.

## VIII. GREENHOUSE GAS EMISSIONS

Environmental Issue	Where were impacts analyzed previously?	Do proposed changes/ new circumstances/ new information result in new significant/ substantially more severe impacts?	Is there substantial new information requiring new analysis or verification?	Do mitigation measures from prior documents resolve significant impacts?
Would the Project:				
a) Generate greenhouse gas emissions, either directly or indirectly, that may have a significant impact on the environment?	DEIR Impacts GCC-1 and GCC-2	No	No	N/A
b) Conflict with an applicable plan, policy or regulation adopted for the purpose of reducing the emissions of greenhouse gases?	DEIR Impacts GCC-1 and GCC-2	No	No	N/A

### SUMMARY OF EIR ANALYSIS

Impacts from implementation of the Yolo County General Plan are evaluated in the Yolo County General Plan Draft EIR in Chapter IV, Section F, "Global Climate Change," and are listed below.

- ▶ Greenhouse Gas Emissions. Impact GCC-1: Build-out of the Draft General Plan would result in greenhouse gas emissions that would have a significant physical adverse impact and cumulatively contribute to global climate change. Even with mitigation, this impact would be significant and unavoidable.
- ▶ Impacts to the Proposed Project from Global Climate Change. Impact GCC-2: While uncertainty exists in the degree to which the effects of climate change will occur, it is likely that significant adverse physical impacts from the effects of global climate change will occur on existing and future planned land uses in the County by 2030. No feasible mitigation is available, and this impact would be significant and unavoidable.
- ▶ Conflict with Plans and Policies of Other Agencies. This impact would be less than significant.
- ▶ Result in Adverse Impacts from Draft General Plan Policies Compared to 1983 General Plan Policies. This impact would be beneficial.

### CONSISTENCY EVALUATION

Yolo County approved the project through the issuance of a Site Plan Review and NOE, copies of which are included in Appendix A. The Site Plan Review issued for the project identifies standard requirements related to air quality (see Section III, "Air Quality"), which would also apply to GHG emissions, and are being implemented by the applicant. Because the project was determined to be consistent with the General Plan, including its land use element, project-related effects related to GHG emissions would be consistent with and were covered by the analysis and conclusions of the Yolo County General Plan EIR. No element of the project would change the conclusions of the Yolo County General Plan EIR or result in new or substantially more severe impacts, and no additional environmental review is needed for the project related to GHG emissions.

## IX. HAZARDS AND HAZARDOUS MATERIALS

Environmental Issue	Where were impacts analyzed previously?	Do proposed changes/ new circumstances/ new information result in new significant/ substantially more severe impacts?	Is there substantial new information requiring new analysis or verification?	Do mitigation measures from prior documents resolve significant impacts?
Would the Project:				
a) Create a significant hazard to the public or the environment through the routine transport, use, or disposal of hazardous materials?	DEIR pages 723-724	No	No	N/A
b) Create a significant hazard to the public or the environment through reasonably foreseeable upset and/or accident conditions involving the release of hazardous materials into the environment?	DEIR pages 723-724	No	No	N/A
c) Emit hazardous emissions or handle hazardous or acutely hazardous materials, substances, or waste within one-quarter mile of an existing or proposed school?	DEIR page 725	No	No	N/A
d) Be located on a site which is included on a list of hazardous materials sites compiled pursuant to Government Code Section 65962.5 and, as a result, would it create a significant hazard to the public or the environment?	DEIR Impact HAZ-1	No	No	N/A
e) For a project located within an airport land use plan or, where such a plan has not been adopted, within two miles of a public airport or public use airport, would the project result in a safety hazard or excessive noise for people residing or working in the project area?	DEIR Impact HAZ-3	No	No	N/A
f) Impair implementation of or physically interfere with an adopted emergency response plan or emergency evacuation plan?	DEIR Impact HAZ-2	No	No	N/A
g) Expose people or structures, either directly or indirectly, to a significant risk of loss, injury, or death involving wildland fires?	DEIR page 726	No	No	N/A

## SUMMARY OF EIR ANALYSIS

Impacts from implementation of the Yolo County General Plan are evaluated in the Yolo County General Plan Draft EIR in Chapter IV, Section M, "Hazards and Hazardous Materials," and are listed below.

- ▶ Exposure from the Use, Storage, Generation, Disposal or Release of Hazardous Materials. This impact would be less than significant.
- ▶ Expose Public or Environment to Hazardous Materials From Hazardous Materials Sites and Historical Land Uses. Impact HAZ-1: The public may be exposed to health risks from agricultural chemical residues in soils as a result of redevelopment of former agricultural properties that may occur under the Draft General Plan. This impact would be less than significant after mitigation.
- ▶ Expose Schools and Other Sensitive Receptors to Hazardous Materials. This impact would be less than significant.
- ▶ Impair Emergency Response or Evacuation Plans Impact HAZ-2: New development under the Draft General Plan may impair emergency response during peak traffic periods. No feasible mitigation is available, and this impact would be significant and unavoidable.
- ▶ Expose People to Fire Risks or Other New Health and Safety Hazards. This impact would be beneficial.
- ▶ Expose People to Risks from Aviation Hazards. Impact HAZ-3: The public may be exposed to safety hazards due to new development near private and informal airstrips. This impact would be less than significant after mitigation.
- ▶ Conflict with Plans and Policies of Other Agencies. This impact would be less than significant.
- ▶ Result in Adverse Impacts from Draft General Plan Policies Compared to 1983 General Plan Policies. This impact would be beneficial.

## CONSISTENCY EVALUATION

Yolo County approved the project through the issuance of a Site Plan Review and NOE, copies of which are included in Appendix A. The Site Plan Review issued for the project identifies the following standard requirements related to hazards and hazardous materials, which are being implemented by the applicant:

- ▶ Prior to handling hazardous materials in quantities equal to or greater than 55-gallons for liquids, 500-pounds for solids, or 200-cubic feet for compressed gases, a Hazardous Materials Business Plan (HMBP) must be completed and submitted to Yolo County Environmental Health (YCEH). Starting January 1, 2013, this must be done by going to the California Environmental Reporting System (CERS) web site (<http://cers.calepa.ca.gov/>), creating an account, entering required facility information, hazardous materials inventory, and emergency response and training plans, and submitting the information for approval by Yolo County Environmental Health. For assistance with CERS, please visit our web site at <https://www.yolocounty.org/government/general-governmentdepartments/community-services/environmental-health-division/hazardousmaterials-programs/california-environmental-reporting-system-cers> or call YCEH at (530) 666-8646 and ask to speak to a Hazmat Specialist. If a facility only generates below-reportable quantities of hazardous waste, it is not required to submit a HMBP in CERS, but the facility will be regulated by our Hazardous Materials (CUPA) program. Please contact our office and ask to speak to a Hazmat Specialist. The reporting thresholds for certain gases are higher, and that for extremely hazardous materials or radiological materials are lower. Please call our office and ask to speak to a Hazmat Specialist.
- ▶ Prior to above ground storage tanks (AST) or containers with an aggregate storage capacity of 1,320-gallons or more in containers 55-gallons and larger for liquid petroleum products being present at the facility, a Spill Prevention, Control, and Countermeasure (SPCC) Plan must be prepared, implemented, and retained on site. This requirement does not apply to propane. This must be done before beginning operations. For further information, please see: <https://www.yolocounty.org/government/general-governmentdepartments/community-services/environmental-health-division/hazardousmaterials-programs/aboveground-storage-tank-program>. Farm facilities may be exempt from the requirement to prepare an SPCC if they store less than 100,000-gallons of petroleum in aboveground tanks and no single tank is larger than 20,000-gallons, AND: 1) conducts daily

inspections of their containers and keeps a written log, 2) allows YCEH to conduct periodic inspections, and 3) the facility constructs secondary containment if YCEH determines that it is required. For questions, please call YCEH at (530) 666-8646 and ask to speak to a Hazmat Specialist.

Because the project was determined to be consistent with the General Plan, including its land use element, project-related effects related to hazards and hazardous materials would be consistent with and were covered by the analysis and conclusions of the Yolo County General Plan EIR. No element of the project would change the conclusions of the Yolo County General Plan EIR or result in new or substantially more severe impacts, and no additional environmental review is needed for the project related to hazards and hazardous materials.

## X. HYDROLOGY AND WATER QUALITY

Environmental Issue	Where were impacts analyzed previously?	Do proposed changes/ new circumstances/ new information result in new significant/ substantially more severe impacts?	Is there substantial new information requiring new analysis or verification?	Do mitigation measures from prior documents resolve significant impacts?
Would the Project:				
a) Violate any water quality standards or waste discharge requirements or otherwise substantially degrade surface or groundwater quality?	SED Impact IX.a and f; DEIR HYD-3.b(1), 3.b(4)	No	No	N/A
b) Substantially decrease groundwater supplies or interfere substantially with groundwater recharge such that the project may impede sustainable groundwater management of the basin?	DEIR HYD-3.b(4),- Impact HYD-1; Impact UTIL-2	No	No	Yes
c) Substantially alter the existing drainage pattern of the site or area, including through the alteration of the course of a stream or river or through the addition of impervious surfaces, in a manner which would:				
i) Result in substantial on- or offsite erosion or siltation;	DEIR HYD-3.b(3)	No	No	N/A
ii) Substantially increase the rate or amount of surface runoff in a manner which would result in flooding on- or offsite;	DEIR HYD-3.b(2)	No	No	N/A
iii) Create or contribute runoff water which would exceed the capacity of existing or planned stormwater drainage systems or provide substantial additional sources of polluted runoff; or	DEIR UTIL-3.c.(2)	No	No	N/A
iv) Impede or redirect flood flows?	DEIR HYD-3.b(5)- Impact HYD-2	No	No	N/A
d) In flood hazard, tsunami, or seiche zones, risk release of pollutants due to project inundation?	DEIR HYD-3.b(5)- Impact HYD-2; HYD-3.b(6); HYD-3.b(7)- Impact HYD-3	No	No	N/A
e) Conflict with or obstruct implementation of a water quality control plan or sustainable groundwater management plan?	DEIR HYD- 3.b(9)	No	No	N/A

## SUMMARY OF EIR ANALYSIS

This topic is addressed in Section 5.9, "Hydrology and Water Quality," of the *Central Valley Salt and Nitrate Management Plan Substitute Environmental Document (SED)*. This topic is also addressed in Section K, "Hydrology and Water Quality," and Section H, "Utilities and Energy," of the *Yolo County General Plan Draft EIR*.

### Impact Analysis

Impacts from implementation of the Salt and Nitrate Management Plan (SNMP) are evaluated in the SED (pages 98 through 117) and are summarized below.

Would the project violate any water quality standards or waste discharge requirements or otherwise substantially degrade surface or ground water quality.

- ▶ In implementing SNMP strategies and policies such as the Salt Control Program and Exceptions Policy, potentially significant water quality impacts are considered to be foreseeable when either there would be long-term degradation of one or more water quality constituent(s) or parameter(s) in a groundwater basin or sub-basin that would result in a substantially increased likelihood for adverse effects to one or more beneficial use(s) of the water body or groundwater basin/sub-basin; or groundwater that currently exceeds applicable salinity, nitrate, or secondary maximum contaminant level (MCL) constituent objectives/criteria to be further degraded, on a long-term average basis. However, such impacts would be considered less than significant if the magnitude, duration, and/or geographic extent of the anticipated degradation is not expected to adversely affect beneficial uses or further degrade the quality of already polluted waters.
- ▶ Impacts from implementation of the Yolo County General Plan are evaluated in the Draft EIR (pages 431 through 513 and 670 through 677) and are summarized below.

Would the project violate any water quality standards or waste discharge requirements or otherwise substantially degrade surface or ground water quality.

- ▶ Implementation of the General Plan policies and actions (including Policy CO-5.23 that states the County would support efforts to meet applicable water quality standards for all surface and groundwater resources, as well as policies HS-2.3, CO-2.29, CO-5.4 through CO-5.8, CO 5.17, CO-5.22, CO-5.23, CO-A74, CO-A92, and CO-A92 that require compliance with water quality standards in conjunction with compliance with existing regulatory programs) would minimize water quality impacts related to potential violation of water quality standards associated with growth under the General Plan. The impact would be less than significant.

Would the project substantially decrease groundwater supplies or interfere substantially with groundwater recharge such that the project may impede sustainable groundwater management of the basin?

- ▶ Implementation of the General Plan policies would reduce potential impacts to groundwater supply because of new development anticipated under the General Plan. Policy CO-5.3 states that the County would manage groundwater resources on a sustainable yield basis that can provide water purveyors and individual users with reliable, high-quality groundwater to serve existing and planned land uses during prolonged drought periods and Policy CO-# states that the County would strive to increase artificial recharge of important aquifers with surplus surface water supplies. Therefore, this impact would be less than significant.

Would the project substantially alter the existing drainage pattern of the site or area, including through the alteration of the course of a stream or river or through the addition of impervious surfaces, in a manner which would:

- i) result in a substantial erosion or siltation on- or off-site;
  - Implementing the General Plan policies would not result in substantial erosion or siltation because development projects completed under the General Plan would be subject to compliance with NPDES regulations that address erosion and sedimentation related to construction projects per the California Construction General Permit. Action CO-A76 also specifies that the County develop a grading ordinance that would assist the County in regulating certain types of grading activities that are most likely to cause water quality impacts. In addition, implementation of the following policies and actions CC-4.3, CO-2.3, CO-5.23,

HS-A.12, and CO-A89 would address potential impacts related to erosion and sedimentation. Implementation of these General Plan policies and actions, in conjunction with compliance with existing regulatory programs would minimize impacts related to increased erosion or sedimentation from growth allowed under the General Plan. The impact would be less than significant.

- ii) substantially increase the rate or amount of surface runoff in a manner which would result in flooding on- or offsite;
- Implementation of the General Plan policies and actions would not substantially increase the rate or amount of surface runoff in a manner which would result in flooding on-or offsite because of actions and policies in the General Plan. Action CO-A90 specifies that the County "adopt design standards that use low-impact development techniques that emulate the natural hydrologic regime and reduce the amount of runoff and associated pollutants." Policies CC-4.3, CC-4.14, PF-2.2, PF-2.4, CC-4.13, CO-2.22, HS-A.9, HS-A.10, CO-A86, CO-A87, CO-A88, CO-A89, and CO-A90 require the construction of on-site stormwater detention facilities, reduction of stormwater flows, maintenance of buffers around water bodies, and protection of riparian corridors. Compliance with these policies and actions in conjunction with compliance with existing regulatory programs would minimize impacts related to increased rate and amounts of stormwater flows under the General Plan. The impact would be less than significant.
- iii) create or contribute runoff water which would exceed the capacity of existing or planned stormwater drainage systems or provide substantial additional sources of polluted runoff; or
- The capacity of stormwater drainage systems is analyzed in Section IV.H, Utilities and Energy of the Yolo County 2030 Countywide General Plan EIR (page 483). General Plan policies CC-4.3, CC-4.14, PF-2.2, PF-2.4, CO-A87, CO-A89, CO-A90, HS-A.9, and HS-A10 address potential impacts related to new development and increased stormwater flows by reducing flows. Specifically, policy PF-2.2 requires the construction of on-site stormwater detention facilities, policy PF-2.4 encourages stormwater management that would provide for groundwater recharge, action CO-A86 requires the County to adopt design mandates to reduce impervious surfaces where possible, action CO-A93 specifies that the County adopt design standards that use low-impact development techniques that emulate the natural hydrologic regime to reduce the amount of runoff and associated pollutants, and policy HS-2 limits the construction of extensive impermeable surfaces. Compliance with the programs and regulations currently in place that regulate storm drainage facilities, including NPDES regulations, the Stormwater Management Plan, and the Stormwater Ordinance, implementation of the General Plan policies and actions described above minimize impacts related to altering drainage patterns and increased runoff associated with stormwater facilities that could be implemented under the General Plan. The impact would be less than significant.
- iv) impede or redirect flood flows?
- Implementation of the General Plan policies and actions would not impede or redirect flood flows because of actions and policies in the General Plan. Several policies and actions of the General Plan, including LU-3.8, HS-2.5, CO-2.22, HS-A7, and HS-A13, would restrict development within flood-prone areas and/or specify specific levels of protection for the new development. Implementation of the following policies and actions would address potential impacts related to new development and an increase stormwater flows that could exacerbate flooding conditions: CC-4.3, CC-4.14, CO-2.29, CO-2.37, HS-A.9, CO-A86, CO-A87, CO-A88, and CO-A90. Additionally, policy CC-4.11 requires site specific information including storm drainage analysis and flood risk analysis to enable informed decision making for project approval, policy HS-2.1 requires the County to manage the development review process to protect people, structures, and personal property from unreasonable risk from flooding and flood hazards, and action HS-A9 requires new developments to detain the stormwater created on-site by a 100-year storm event. Implementation of these policies and actions reduce the risk of flood-flows associated with new development implemented under the General Plan to a less-than-significant level.



Would the project in flood hazard, tsunami, or seiche zones, risk release of pollutants due to project inundation.

- ▶ The General Plan contains a number of policies under Emergency Preparedness in the Health and Safety Element that address preparation for and response to a catastrophic event such as a dam failure. These include goal HS-6, policies HS-6.1 through HS-6.5, and actions HS-53 through HS-A60. With these policies and requirements in place, this is considered a less-than-significant impact.
- ▶ The location and elevation of the County precludes significant impact due to coastal hazards, such as tsunamis or extreme high tides. No seiche occurrences have ever been documented in Yolo County water bodies.
- ▶ Growth and new development under the General Plan would allow new construction in flood zones, including within the 100-year flood hazard boundary, and would increase the number of people and structures subject to flood risks. Several policies and actions of the General Plan, including LU-3.8, HS-2.5, CO-2.22, HS-A7, and HS-A13 restrict development within flood-prone areas and/or specify specific levels of protection for the new development. Implementation of these policies would reduce direct flood-related impacts associated with new development. The County does not believe that avoiding all development within floodplain areas is practical or feasible. Therefore, this impact would be significant and unavoidable.
- ▶ It is possible that sea level rise could reduce the effectiveness of levees within the County. Implementation of General Plan action HS-A17 requires that the County "coordinate with local, State and federal agencies to define existing and potential flood problem areas, including the possible impacts associated with global climate change, and to maintain and improve levees and other flood control features." With implementation of this action, potential impacts related to sea level rise may be partially addressed, but complete mitigation would not be assured. Sea level rise would exacerbate flooding problems, and therefore flooding associated with sea level rise would be significant and unavoidable.

Would the project conflict with or obstruct implementation of a water quality control plan or sustainable groundwater management plan?

- ▶ Implementation of the General Plan would not result in environmental impacts to hydrology or water resources stemming from conflict with any of the relevant regional plans. As a result, implementation of the General Plan would result in a less-than-significant impact related to policy conflicts with other agencies in regards to hydrology and water quality.

## Yolo County General Plan Policy Requirements

The General Plan contains several policies and actions designed to implement the County's strategies for preserving and protecting hydrologic resources and water quality. These goals and actions are listed on pages 482 through 483 and 663 through 670 of the Draft EIR.

## Mitigation Measures

The following mitigation measures were identified in the Yolo County General Plan EIR for hydrology and water quality:

- ▶ Mitigation Measure HYD-1a: amend Policy CO-5.3 of the Draft General Plan as follows:
- ▶ Policy CO-5.3: ~~Strive to~~ Manage the County's groundwater resources on a sustainable yield basis that can provide water purveyors and individual users with reliable, high quality groundwater to serve existing and planned land uses during prolonged drought periods.
- ▶ Mitigation Measure HYD-1b: The Draft General Plan shall be amended to include the following new policy in the Conservation and Open Space Element.
- ▶ Policy CO-#: Strive to increase artificial recharge of important aquifers with surplus surface water supplies.
- ▶ Mitigation Measure HYD-2: None available.
- ▶ Mitigation Measure HYD-3: None available.

The Yolo County General Plan EIR concluded that implementation of these mitigation measures would reduce impacts to hydrology and water quality resources to a less-than-significant level for Impact HYD-1a and 1b, but the potential impacts would remain significant and unavoidable for Impacts HYD-2 and HYD-3.

## CONSISTENCY EVALUATION

### Salt and Nitrate Management Plan Substitute Environmental Document

Facility operations would include hulling, drying, storage, fumigation, roasting, and pasteurization. Process wastewater would be generated during hulling, equipment cleanup, and pasteurization. Most of the process wastewater would be from the hulling, washing, and sorting of the nuts. Pistachio wastewater has high concentrations of salinity (electrical conductivity [EC] and total dissolved solids [TDS]). Based on available groundwater data at pre-discharge conditions, groundwater is not identified as high-quality water. Pre-discharge TDS concentrations exceed 500 mg/L, the recommended secondary maximum contaminant level for TDS. Pre-discharge EC concentrations exceed 700  $\mu\text{mhos/cm}$ , the conservative numeric value that is considered to be protective of the agricultural beneficial use. As described in the Order, the project's discharges of salt will be regulated pursuant to the SNMP Salt Control Program (SCP), through which the facility may participate in the alternative salinity permitting program if it maintains membership in good standing with the regionwide Prioritization and Optimization (P&O) Study. The Groundwater Sub-basin 5-21.52 (Colusa Subbasin) to which the facility would discharge currently exceeds conservative numeric values for salinity for protection of municipal and agricultural beneficial uses. With respect to nitrate, pistachio wastewater is primarily total Kjeldahl nitrogen, consisting of organic nitrogen and ammonia nitrogen, which has the potential to mineralize and convert to nitrate. Based on available groundwater data at pre-discharge conditions, nitrate in groundwater is not identified as high-quality water. Pre-discharge nitrate conditions within locations where the discharge of pistachio waste will occur, exceed 10 mg/L, the primary maximum contaminant level for nitrate. As described in the Order, a time schedule will be issued requiring that the discharger must implement to maintain compliance with the SNMP Nitrate Control Program (NCP). While the facility's discharge may, to a limited extent, degrade underlying groundwater with respect to salinity and nitrate and/or result in a substantially increased likelihood for adverse effects to beneficial uses of the groundwater within the immediate vicinity of the discharge, these impacts are anticipated to be limited in magnitude, scope, and duration. (See SED, pp. 99, 101.) While the short-term impacts of the project may be potentially significant in the near-term, any such impacts would be reduced to less than significant over the long-term through implementation of Phases II and III of the SCP (See SED, p.,101.). No element of the project would change the conclusions of the SED or result in new or substantially more severe impacts, and no additional environmental review is needed for the project related to water quality. Specific actions associated with the project that would reduce degradation of groundwater are described in the paragraphs below.

Zamora Pistachio will provide control of the discharge that incorporates best management practices (BMPs) and best practical treatment or control (BPTC)/best efforts measures to protect water quality, minimize impacts to groundwater quality that is not identified as high-quality water, and prevent nuisance from occurring. The initial BMP is appropriate water utilization rates. While not necessarily reducing the constituent mass generated, water conservation is beneficial in conserving water supplies and energy use. The amount of water used in the hulling process is the minimum amount necessary to maintain quality, avoid discoloration and prevent the formation of aflatoxin. Excessive water use is inherently discouraged due to the additional cost to pump, convey, filter, and chlorinate the process water as well as manage its reuse.

Numerous BPTCs/best efforts will be employed to manage the process water after the hulling process. Hulling process water is captured in tanks, routed through several filtration steps to significantly reduce the TSS. Removal of solids serves to remove insoluble BOD consisting of particulate matter, colloidal solids (protein) and lipids (fats and oils). Prior to land application, the treated water is retained in a pond only for a short time to prevent hydrolysis and degradation of insoluble BOD that remain after the solids removal process. While in the pond, the wastewater is aerated to supply and maintain dissolved oxygen levels necessary to prevent septicity and odor production. Hull materials which are the primary source of nitrogen in the wastewater are shipped offsite for beneficial use.

Wastewater is used primarily as an irrigation supplement on Zamora's highly valued pistachio orchards. The application rate is managed to ensure that it is consistent with agronomic rates as verified by leaf and tissue analysis and that sufficient resting periods are scheduled between applications of wastewater. Most of the pistachio orchards will be planted with a cover crop to reduce nitrogen loading. Soils are disked as needed in the land application areas (LAAs) without a cover crop. Any construction and operation of specific projects for salt and nitrate management would undergo separate project-specific environmental review and permitting. Through these processes, this project is expected to be sited, constructed, and operated in a manner that would not cause violation of water quality standards or waste discharge requirements. No element of the project would change the conclusions of the SED or result in new or substantially more severe impacts, and no additional environmental review is needed for the project related to water quality.

Zamora Pistachio will comply with the Waste Discharge Requirements (WDR) Order R5-2024-XXXX when it is issued by the Regional Board. The Draft WDR requires the following requirements related to hydrology and water quality, which will be implemented by the applicant:

- ▶ Hulling water will be collected in concrete-lined pits and routed through several filtration steps to reduce the total suspended solids before entering the wastewater pond. Wastewater undergoes additional filtration prior to application to the LAAs.
- ▶ The wastewater pond will be clay-lined and aerated, which will help to reduce BOD and odors. Wastewater pond use is limited to the harvest season. Process wastewater will be retained in the pond for a short time, prior to being discharged to the LAAs.
- ▶ Approximately 440 acres of LAAs will be available. Crops (pistachios and cover crops including but not limited to winter wheat) will be planted in the LAAs to assimilate nutrients in the treated wastewater and harvested and removed from the site.
- ▶ Application of wastewater to the LAAs will be at agronomic rates.
- ▶ Biochemical Oxygen Demand cycled average loading rates will not exceed 100 lbs/acre/day.
- ▶ Participation and compliance with the Salt and Nitrogen Control Plans: To maintain existing salt discharges and minimize salinity impacts, this Order requires the Discharger to implement efforts to control salinity in its discharge to the extent reasonable, feasible, and practicable; and sets a Performance Based Salinity Limit of 2,200 mg/L for Fixed Dissolved Solids as a flow-weighted annual average on the discharge of wastewater (hulling wastewater and supplemental irrigation water including pasteurizer condensate and equipment/plant wash water) sent to the LAAs. The Discharger submitted a Notice of Intent and elected to participate in the Prioritization and Optimization Study under the Alternative Salinity Permitting Approach for the Salt Control Program. Dischargers proposing new or expanded discharges of nitrate to any groundwater basin/sub-basin, regardless of priority must comply with the Nitrate Control Program. This Order includes a compliance schedule requiring the Discharger to (1) conduct a Sensitive Receptor Survey and determine if any water supply wells are impacted by the Discharger's discharge of nitrate, (2) implement an Early Action Plan as needed, and (3) implement an Alternative Compliance Project(s) as needed.

## Yolo County General Plan EIR

Yolo County approved the project through the issuance of a Site Plan Review and NOE, copies of which are included in Appendix A. The Site Plan Review issued for the project identifies the following standard requirements related to hydrology and water quality, which are being implemented by the applicant:

- ▶ If the development disturbs one acre or more of land, the developer must obtain coverage under California's "National Pollutant Discharge Elimination System (NPDES) General Permit for Storm Water Discharges Associated with Construction and Land Disturbance Activities (State General Permit)" for controlling construction activities that may adversely affect water quality. State General Permit coverage requires preparation of a Storm Water Pollution Prevention Plan (SWPPP). The developer shall provide Yolo County its State-issued Waste Discharge Identification Number (WDID #), and pay associated fees, prior to issuance of a County building or grading permit.
- ▶ The applicant shall provide a hydrology/hydraulic report, signed and sealed by a professional civil engineer licensed in the State of California that complies with Section 9 Storm Drainage of the Yolo County Improvements

Standards and uses methods outlined in the Yolo County City/County Drainage Manual. The report will be submitted for review and approval by the County Engineer prior to grading or building permit issuance for Phase 1. Conclusions need to discuss the upstream and downstream impacts caused by the development of the project (planned, full build out) and how the improvements mitigate impacts in accordance with the standards. The applicant shall reimburse the County for all activities associated with review of the report.

- ▶ Prior to grading/building permit issuance for Phase 1, an operations and maintenance plan (O&M plan) shall be submitted for Public Works review that ensures the onsite storm drainage facilities will receive appropriate annual and routine inspections, maintenance, and operation (including, but not limited to, drop inlets, inlet filters, bioswales, pipelines, detention basins, etc.; can be as brief as one page, but specific on how the owner is to properly maintain the storm water drainage system going forward).
- ▶ The significant and unavoidable conclusions reached for flood impacts in the Yolo County General Plan EIR are not applicable to the project because the project site is not located in a 100-year flood zone. Because the project was determined to be consistent with the General Plan, including its land use element, project-related effects related to hydrology and water quality would be consistent with and were covered by the analysis and conclusions of the Yolo County General Plan EIR. No element of the project would change the conclusions of the Yolo County General Plan EIR or result in new or substantially more severe impacts, and no additional environmental review is needed for the project related to hydrology and water quality.

## XI. LAND USE AND PLANNING

Environmental Issue	Where were impacts analyzed previously?	Do proposed changes/ new circumstances/ new information result in new significant/ substantially more severe impacts?	Is there substantial new information requiring new analysis or verification?	Do mitigation measures from prior documents resolve significant impacts?
Would the Project:				
a) Physically divide an established community?	DEIR Impact LU-1	No	No	N/A
b) Cause a significant environmental impact due to a conflict with any land use plan, policy, or regulation adopted for the purpose of avoiding or mitigating an environmental effect?	DEIR Impact LU-5	No	No	N/A

### SUMMARY OF EIR ANALYSIS

Impacts from implementation of the Yolo County General Plan are evaluated in the Yolo County General Plan Draft EIR in Chapter IV, Section A, "Land Use and Housing," and are listed below.

- ▶ Disrupt or Divide an Established Community. Impact LU-1: Build-out of the Draft General Plan could disrupt or physically divide established communities. The impact would be less than significant after mitigation.
- ▶ Create Land Use Incompatibilities. Impact LU-2: Build-out of the Draft General Plan could create substantial incompatibilities between land uses. Even with mitigation, this impact would be significant and unavoidable.
- ▶ Conflict with Policies of Other County Plans. The impact would be less than significant.
- ▶ Conflict with Plans or Policies of Other Agencies. Impact LU-5: Build-out of the Draft General Plan would result in conflicts with the plans and policies of other agencies. The impact would be less than significant after mitigation.
- ▶ Result in Adverse Impacts from Draft General Plan Policies Compared to 1983 General Plan Policies. The impact would be less than significant.

### CONSISTENCY EVALUATION

Yolo County approved the project through the issuance of a Site Plan Review and NOE, copies of which are included in Appendix A. Because the project was determined to be consistent with the General Plan, including its land use element, project-related effects related to land use and planning would be consistent with and were covered by the analysis and conclusions of the Yolo County General Plan EIR. As an agricultural use on agricultural land, it would not disrupt or divide a community, create land use incompatibilities, conflict with the policies of other county plans or otherwise cause a land use impact. No element of the project would change the conclusions of the Yolo County General Plan EIR or result in new or substantially more severe impacts, and no additional environmental review is needed for the project related to land use and planning.

## XII. MINERAL RESOURCES

Environmental Issue	Where were impacts analyzed previously?	Do proposed changes/ new circumstances/ new information result in new significant/ substantially more severe impacts?	Is there substantial new information requiring new analysis or verification?	Do mitigation measures from prior documents resolve significant impacts?
Would the Project:				
a) Result in the loss of availability of a known mineral resource that would be of value to the region and the residents of the state?	DEIR pages 705-706	No	No	N/A
b) Result in the loss of availability of a locally important mineral resource recovery site delineated on a local general plan, specific plan, or other land use plan?	DEIR pages 705-706	No	No	N/A

### SUMMARY OF EIR ANALYSIS

Impacts from implementation of the Yolo County General Plan are evaluated in the Yolo County General Plan Draft EIR in Chapter IV, Section L, "Geology, Soils, Seismicity, and Mineral Resources," and are listed below.

- ▶ Loss of Availability of Mineral Resources. This impact would be less than significant.

### CONSISTENCY EVALUATION

Yolo County approved the project through the issuance of a Site Plan Review and NOE, copies of which are included in Appendix A. Because the project was determined to be consistent with the General Plan, including its land use element, project-related effects related to mineral resources would be consistent with and were covered by the analysis and conclusions of the Yolo County General Plan EIR. There are no known mineral resources on the site and no mineral resource zones are designated on the property. No element of the project would change the conclusions of the Yolo County General Plan EIR or result in new or substantially more severe impacts, and no additional environmental review is needed for the project related to mineral resources.

### XIII. NOISE

Environmental Issue	Where were impacts analyzed previously?	Do proposed changes/new circumstances/ new information result in new significant/ substantially more severe impacts?	Is there substantial new information requiring new analysis or verification?	Do mitigation measures from prior documents resolve significant impacts?
Would the Project:				
a) Generation of a substantial temporary or permanent increase in ambient noise levels in the vicinity of the project in excess of standards established in the local general plan or noise ordinance, or in other applicable local, state, or federal standards?	DEIR Impacts NOI-1, NOI-2, NOI-3	No	No	N/A
b) Generation of excessive groundborne vibration or groundborne noise levels?	DEIR NOI-4	No	No	N/A
c) For a project located within the vicinity of a private airstrip or an airport land use plan or, where such a plan has not been adopted, within two miles of a public airport or public use airport, would the project expose people residing or working in the project area to excessive noise levels?	DEIR pages 331-332	No	No	N/A

### SUMMARY OF EIR ANALYSIS

Impacts from implementation of the Yolo County General Plan are evaluated in the Yolo County General Plan Draft EIR in Chapter IV, Section E, "Noise," and are listed below.

- ▶ Exposure to Noise in Excess of Standards. Impact NOI-1: Increased traffic from build-out of the proposed Draft General Plan would result in a significant increase in traffic noise levels on roadway segments throughout the County. No feasible mitigation is available, and this impact would be significant and unavoidable.
- ▶ Exposure to Noise in Excess of Standards. Impact NOI-2: Build-out of the proposed Draft General Plan would result in traffic noise levels in excess of the County's normally acceptable standard of 60 dBA L<sub>dn</sub> for new noise sensitive land use development. This impact would be less than significant after mitigation.
- ▶ Exposure to Vibration Impacts. This impact would be less than significant.
- ▶ Exposure to Aircraft Noise Impacts. This impact would be less than significant.
- ▶ Exposure to Stationary Noise Impacts and Resulting Increases in Ambient Noise. Impact NOI-3: Build-out of the proposed Draft General Plan would result in a substantial or periodic increase in ambient noise levels. No feasible mitigation is available, and this impact would be significant and unavoidable.
- ▶ Exposure to Stationary Noise Impacts and Resulting Increases in Ambient Noise. Impact NOI-4: Build-out of the proposed Draft General Plan would result in excessive groundborne vibration levels from construction activities. This impact would be less than significant after mitigation.
- ▶ Conflicts with Other Plans. This impact would be less than significant.
- ▶ Result in Adverse Impacts from Draft General Plan Policies Compared to 1983 General Plan Policies. This impact would be less than significant.

## CONSISTENCY EVALUATION

Yolo County approved the project through the issuance of a Site Plan Review and NOE, copies of which are included in Appendix A. Because the project was determined to be consistent with the General Plan, including its land use element, project-related effects related to noise would be consistent with and were covered by the analysis and conclusions of the Yolo County General Plan EIR. No element of the project would change the conclusions of the Yolo County General Plan EIR or result in new or substantially more severe impacts, and no additional environmental review is needed for the project related to noise.



## XIV. POPULATION AND HOUSING

Environmental Issue	Where were impacts analyzed previously?	Do proposed changes/ new circumstances/ new information result in new significant/ substantially more severe impacts?	Is there substantial new information requiring new analysis or verification?	Do mitigation measures from prior documents resolve significant impacts?
Would the Project:				
a) Induce substantial unplanned population growth in an area, either directly (for example, by proposing new homes and businesses) or indirectly (for example, through extension of roads or other infrastructure)?	DEIR Impact LU-3	No	No	N/A
b) Displace substantial numbers of existing people or housing, necessitating the construction of replacement housing elsewhere?	DEIR pages 142-143	No	No	N/A

### SUMMARY OF EIR ANALYSIS

Impacts from implementation of the Yolo County General Plan are evaluated in the Yolo County General Plan Draft EIR in Chapter IV, Section A, "Land Use and Housing," and are listed below.

- ▶ Alter Land Use Type or Intensity. Impact LU-3: Build-out of the Draft General Plan would substantially alter the type and intensity of land uses within the community areas of the unincorporated County. Even with mitigation, this impact would be significant and unavoidable.
- ▶ Displace Housing Units or People. The impact would be less than significant.
- ▶ Jobs/Housing Balance and Match. Impact LU-4: Land uses and development consistent with the Draft General Plan would fail to achieve a jobs/housing balance and match in some community areas and could potentially exacerbate an existing jobs/housing imbalance in some community areas. Even with mitigation, this impact would be significant and unavoidable.
- ▶ State Regional Housing Needs Allocation. The impact would be less than significant.

### CONSISTENCY EVALUATION

Yolo County approved the project through the issuance of a Site Plan Review and NOE, copies of which are included in Appendix A. Because the project was determined to be consistent with the General Plan, including its land use element, project-related effects related to population and housing would be consistent with and were covered by the analysis and conclusions of the Yolo County General Plan EIR. No element of the project would change the conclusions of the Yolo County General Plan EIR or result in new or substantially more severe impacts, and no additional environmental review is needed for the project related to population and housing.

## XV. PUBLIC SERVICES

Environmental Issue	Where were impacts analyzed previously?	Do proposed changes/new circumstances/ new information result in new significant/ substantially more severe impacts?	Is there substantial new information requiring new analysis or verification?	Do mitigation measures from prior documents resolve significant impacts?
Would the Project:				
a) Result in substantial adverse physical impacts associated with the provision of new or physically altered governmental facilities, or the need for new or physically altered governmental facilities, the construction of which could cause significant environmental impacts, in order to maintain acceptable service ratios, response times, or other performance objectives for any of the public services:				
i. Fire protection?	DEIR Impact PUB-1	No	No	N/A
ii. Police protection?	DEIR pages 376-379	No	No	N/A
iii. Schools?	DEIR Impact PUB-2	No	No	N/A
iv. Parks?	DEIR Impact PUB-3	No	No	N/A
v. Other public facilities?	DEIR pages 411-412 (libraries); pages 416-417 (social services)	No	No	N/A

## SUMMARY OF EIR ANALYSIS

Impacts from implementation of the Yolo County General Plan are evaluated in the Yolo County General Plan Draft EIR in Chapter IV, Section G, "Public Services," and are listed below.

- ▶ Law Enforcement. The impact would be less than significant.
- ▶ Fire Protection. Impact PUB-1: Growth associated with build-out of the Draft General Plan would generate a demand for fire protection and emergency services that may exceed the ability of the fire districts and departments to meet established service thresholds. The impact would be less than significant after mitigation.
- ▶ School Services. Impact PUB-2: Growth occurring under the Draft General Plan would generate a demand for school services beyond the existing public school capacity and may result in the need for additional facilities to the degree that acceptable services ratios may not be met concurrent with new growth. The impact would be less than significant after mitigation.
- ▶ Libraries. The impact would be less than significant.
- ▶ Social Services. The impact would be less than significant.

- ▶ Community Parks and Resource Areas. Impact PUB-3: Growth occurring under the Draft General Plan would generate a demand for community parks and resource parks to the degree that service thresholds may not be met concurrent with new growth. The impact would be less than significant after mitigation.
- ▶ Conflict with Plans or Policies of Other Agencies. The impact would be less than significant.
- ▶ Result in Adverse Impacts from Draft General Plan Policies Compared to 1983 General Plan Policies. The impact would be less than significant.

## CONSISTENCY EVALUATION

Yolo County approved the project through the issuance of a Site Plan Review and NOE, copies of which are included in Appendix A. Because the project was determined to be consistent with the General Plan, including its land use element, project-related effects related to public services would be consistent with and were covered by the analysis and conclusions of the Yolo County General Plan EIR. No element of the project would change the conclusions of the Yolo County General Plan EIR or result in new or substantially more severe impacts, and no additional environmental review is needed for the project related to public services.

## XVI. RECREATION

Environmental Issue	Where were impacts analyzed previously?	Do proposed changes/ new circumstances/ new information result in new significant/ substantially more severe impacts?	Is there substantial new information requiring new analysis or verification?	Do mitigation measures from prior documents resolve significant impacts?
Would the Project:				
a) Increase the use of existing neighborhood and regional parks or other recreational facilities such that substantial physical deterioration of the facility would occur or be accelerated?	DEIR Impact PUB-3	No	No	N/A
b) Include recreational facilities or require the construction or expansion of recreational facilities that might have an adverse physical effect on the environment?	Not evaluated	No	No	N/A

## SUMMARY OF EIR ANALYSIS

Impacts from implementation of the Yolo County General Plan are evaluated in the Yolo County General Plan Draft EIR in Chapter IV, Section G, "Public Services," and are listed below.

- ▶ Community Parks and Resource Areas. Impact PUB-3: Growth occurring under the Draft General Plan would generate a demand for community parks and resource parks to the degree that service thresholds may not be met concurrent with new growth. The impact would be less than significant after mitigation.

## CONSISTENCY EVALUATION

Yolo County approved the project through the issuance of a Site Plan Review and NOE, copies of which are included in Appendix A. Because the project was determined to be consistent with the General Plan, including its land use element, project-related effects related to recreation would be consistent with and were covered by the analysis and conclusions of the Yolo County General Plan EIR. No element of the project would change the conclusions of the Yolo County General Plan EIR or result in new or substantially more severe impacts, and no additional environmental review is needed for the project related to recreation.

## XVII. TRANSPORTATION

Senate Bill 743, passed in 2013, required the Governor's Office of Planning and Research to develop new CEQA Guidelines that address traffic metrics under CEQA. As stated in the legislation (and Section 21099[b][2] of CEQA), upon adoption of the new CEQA guidelines, "automobile delay, as described solely by level of service (LOS) or similar measures of vehicular capacity or traffic congestion shall not be considered a significant impact on the environment pursuant to this division, except in locations specifically identified in the CEQA guidelines, if any."

The Office of Administrative Law approved the updated CEQA Guidelines on December 28, 2018, and the changes are reflected in new CEQA Guidelines (Section 15064.3). State CEQA Guidelines Section 15064.3 was added December 28, 2018, to address the determination of significance for transportation impacts. Pursuant to the new CEQA Guidelines, vehicle miles traveled (VMT) will replace congestion as the metric for determining transportation impacts. The CEQA Guidelines state that "lead agencies may elect to be governed by these provisions of this section immediately. Beginning July 1, 2020, the provisions of this section shall apply statewide." As of December 28, 2018, "automobile delay, as described solely by level of service [LOS] or similar measures of vehicular capacity or traffic congestion shall not be considered a significant impact on the environment pursuant to this division, except in locations specifically identified in the guidelines, if any." (Pub. Resources Code, § 21099, subd. (b)(2); see also *Citizens for Positive Growth & Preservation v. City of Sacramento* (2019) 43 Cal.App.5th 609, 625-626.)

The Yolo County General Plan EIR was certified in 2009. As described above, the updated CEQA Guidelines were not adopted until December 28, 2018, subsequent to certification of the Yolo County General Plan EIR in 2009. Section 15007 of the CEQA Guidelines addresses amendments to the CEQA Guidelines and states: "If a document meets the content requirements in effect when the document is sent out for public review, the document shall not need to be revised to conform to any new content requirements in Guideline amendments taking effect before the document is finally approved." (CEQA Guidelines Section 15007[c]) Stated another way, because the EIR was circulated for public review (and completed) long before this change in the CEQA Guidelines, the new provisions regarding VMT do not apply to this project.

For these reasons, the shift from automobile delay to VMT as the primary metric used to analyze transportation impacts under CEQA, as dictated by CEQA Guidelines Section 15064.3, does not constitute either "significant new information" as defined in CEQA Guidelines section 15088.5 (recirculation) or "new information" as defined in CEQA Guidelines Section 15162 (subsequent review). And even if might constitute "significant new information" or "new information" under those definitions, CEQA Guidelines Section 15007, subdivision (c), specifically directs that the document "shall not need to be revised" to reflect this information.

Notwithstanding the timing of the Yolo County General Plan EIR in context of the VMT shift in CEQA, the Yolo County General Plan EIR did address VMT, as described below.

Environmental Issue	Where were impacts analyzed previously?	Do proposed changes/new circumstances/ new information result in new significant/ substantially more severe impacts?	Is there substantial new information requiring new analysis or verification?	Do mitigation measures from prior documents resolve significant impacts?
Would the Project:				
a) Conflict with a program, plan, ordinance or policy addressing the circulation system, including transit, roadway, bicycle, and pedestrian facilities?	DEIR pages 268-269	No	No	N/A
b) Conflict or be inconsistent with CEQA Guidelines section 15064.3, subdivision (b)?	DEIR Impact CI-1	No	No	N/A
c) Substantially increase hazards due to a geometric design feature (e.g., sharp curves or dangerous intersections) or incompatible uses (e.g., farm equipment)?	DEIR Impacts CI-7 and CI-8	No	No	N/A
d) Result in inadequate emergency access?	Not evaluated	No	No	N/A

## SUMMARY OF EIR ANALYSIS

Impacts from implementation of the Yolo County General Plan are evaluated in the Yolo County General Plan Draft EIR in Chapter IV, Section C, "Transportation and Circulation," and are listed below. Notably, many of these impacts relate to "level of service," which is no longer a permissible factor in assessing the significance of traffic impacts under CEQA. (Pub. Resources Code, § 21099, subd. (b)(2).) Even so, the LOS-related impacts are summarized below.

- ▶ Result in Increased Vehicle Miles of Travel. Impact CI-1: Build-out of the Draft General Plan could result in increased vehicle miles of travel. Even with mitigation, this impact would be significant and unavoidable.
- ▶ Result in Increased Peak Hour Traffic Volumes. Impact CI-2: Build-out of the Draft General Plan would add vehicle trips to roadways that would operate below the 1983 Yolo County General Plan level of service (LOS) under cumulative conditions. Even with mitigation, this impact would be significant and unavoidable.
- ▶ Result in Increased Peak Hour Traffic Volumes. Impact CI-3: Build-out of the Draft General Plan would rely upon future roadway capacity expansion projects for which full funding is not ensured. Even with mitigation, this impact would be significant and unavoidable.
- ▶ Result in Increased Peak Hour Traffic Volumes. Impact CI-4: Build-out of the Draft General Plan would contribute vehicle trips to roadways projected to operate worse than the LOS thresholds identified in the Congestion Management Program (CMP) under cumulative conditions. Even with mitigation, this impact would be significant and unavoidable.
- ▶ Result in Increased Peak Hour Traffic Volumes. Impact CI-5: Build-out of the Draft General Plan would contribute vehicle trips to roadways projected to operate worse than the LOS thresholds of the incorporated Cities of Davis, West Sacramento, Winters, and Woodland under cumulative conditions. Even with mitigation, this impact would be significant and unavoidable.
- ▶ Result in Increased Peak Hour Traffic Volumes. Impact CI-6: Build-out of the Draft General Plan would contribute vehicle trips on state highways that would operate worse than the Caltrans LOS threshold under cumulative conditions. Even with mitigation, this impact would be significant and unavoidable.

- ▶ Result in Increased Peak Hour Traffic Volumes. Impact CI-7: Build-out of the Draft General Plan could result in increased travel on roadways that do not meet current design standards. No feasible mitigation is available, and this impact would be significant and unavoidable.
- ▶ Result in Increased Peak Hour Traffic Volumes. Impact CI-8: Build-out of the Draft General Plan could result in increased travel on state facilities that do not meet current design standards. No feasible mitigation is available, and this impact would be significant and unavoidable.
- ▶ Review of Transit, Bicycle, and Pedestrian Policies. The impact would be less than significant.
- ▶ Review of Goods Movement Policies. The impact would be less than significant.
- ▶ Review of Aviation Policies. The impact would be less than significant.
- ▶ Review of Proposed Alternative Sites. The impact would be less than significant.
- ▶ Conflict with Plans or Policies of Other Agencies. The impact would be less than significant.
- ▶ Conflict with 1983 General Plan Circulation Element Policies. Impact CI-9: Build-out of the Draft General Plan would result in an adverse physical environmental impact associated with an increase in traffic on roadways in comparison to the policies of the 1983 General Plan. No feasible mitigation is available, and this impact would be significant and unavoidable.

## CONSISTENCY EVALUATION

Yolo County approved the project through the issuance of a Site Plan Review and NOE, copies of which are included in Appendix A. The Site Plan Review issued for the project identifies the following standard requirements related to transportation, which are being implemented by the applicant:

- ▶ County Road (CR) 95 is not designed or constructed to handle the heavy truck traffic and hauling activities related to this development. Applicant has agreed to provide engineered improvement plans to reconstruct CR 95 within the existing road right-of-way per County Standards for a Rural Street from CR 13 to the southern end of the proposed new driveway approach for the development. Plans shall be signed and sealed by a professional civil engineer in the State of California and reviewed and approved by the County Engineer. Design to include, but is not limited to, eleven-foot-wide travel lanes, minimum one-foot-wide paved shoulders, centerline striping, ZF2022-0054 Zamora Pistachio Huller 5 signage, new pavement limit line and stop legend at CR 13, roadside ditches, and provisions for STAA (Surface Transportation Assistance Act of 1982) vehicle turning radii for all vehicle turning movements. Construction of these improvements shall be completed prior to issuance of Phase 1 building permit(s). An additional hot mix asphalt overlay, or other road structure improvements, may be required by the County Engineer to be installed on this stretch of CR 95 by the applicant prior to issuance of Phase 2 building permit(s). Any repairs, striping, legends, shoulder backing, would be required as well with this Phase 2 work.
- ▶ To improve public safety, applicant has agreed to provide engineered improvement plans per County Standards for installing a left turn pocket on westbound CR 13 for entry into the proposed driveway approach for Phase 2 facilities. Design to include, but is not limited to, transition tapers and deceleration taper for eastbound right turns into the development, striping and signage, roadside ditch realignments, and provisions for STAA (Surface Transportation Assistance Act of 1982) vehicle turning radii for all vehicle turning movements. Any additional county road right-of-way required for this work, if necessary, is to be obtained by the applicant. Plans to be signed and sealed by a professional civil engineer in the State of California and reviewed and approved by the County Engineer. Construction of these improvements shall be completed prior to issuance of Phase 2 building permit(s).
- ▶ Applicant shall secure a county encroachment permit for each phase to construct the public improvements along the project site's frontages on CR 95 and CR 13 according to its corresponding timelines per Standard Requirements #1 and #2, above. Additionally, the scope of work shall also include the construction of commercial driveway connections to CR 95 and CR 13 in Phases 1 and 2, respectively, and bring them into conformance with

Yolo County Improvement Standards. See attached Standard Drawing #4-23. Applicant shall reimburse the County for all activities associated with encroachment permit issuance and inspection (County Zone File ZF2022-0054).

- ▶ Fire Access: Site access for fire engines shall be coordinated with the local fire district chief in compliance with the California Fire Code. Ensure fire apparatus access is available within 150 feet of all portions of the building. Fire apparatus access roads must be a minimum of 20 feet (with no parking permitted on either side.) Fire apparatus access roads must maintain a minimum turning radii of 20 feet interior / 40 feet exterior.

Because the project was determined to be consistent with the General Plan, including its land use element, project-related effects related to transportation would be consistent with and were covered by the analysis and conclusions of the Yolo County General Plan EIR. Most VMT from the project relates to truck traffic, which is not included in guidance related to VMT impacts. No element of the project would change the conclusions of the Yolo County General Plan EIR or result in new or substantially more severe impacts, and no additional environmental review is needed for the project related to transportation.



## XVIII. TRIBAL CULTURAL RESOURCES

Assembly Bill (AB) 52, signed by the California governor in September of 2014, establishes a new class of resources under CEQA: "tribal cultural resources." It requires that lead agencies undertaking CEQA review must, upon written request of a California Native American tribe, begin consultation after the lead agency determines that the application for the project is complete, before a notice of preparation (NOP) of an EIR or notice of intent to adopt a negative declaration or mitigated negative declaration is issued. AB 52 also requires revision to CEQA Appendix G, the environmental checklist. This revision has created a new category for tribal cultural resources (TCRs).

The Yolo County General Plan EIR does not address TCRs because it was not required to do so. The NOP for the Yolo County General Plan EIR was issued in October 2008 (State Clearinghouse No. 2008102034), and AB 52 went into effect on July 1, 2015. Because the NOP was released before AB 52 went into effect, the Yolo County General Plan EIR was not required to address TCRs.

## XIX. UTILITIES AND SERVICE SYSTEMS

Environmental Issue	Where were impacts analyzed previously?	Do proposed changes/ new circumstances/ new information result in new significant/ substantially more severe impacts?	Is there substantial new information requiring new analysis or verification?	Do mitigation measures from prior documents resolve significant impacts?
Would the Project:				
a) Require or result in the relocation or construction of construction of new or expanded water, wastewater treatment or stormwater drainage, electric power, natural gas, or telecommunication facilities, the construction or relocation of which could cause significant environmental effects?	DEIR Impact UTIL-1, pages 461-462 (water), Impact UTIL-3, pages 476-477 (wastewater), 486-487 (stormwater)	No	No	N/A
b) Have insufficient water supplies available to serve the project and reasonably foreseeable future development during normal, dry and multiple dry years?	DEIR Impact UTIL-1	No	No	N/A
c) Result in a determination by the wastewater treatment provider that serves or may serve the project that it has inadequate capacity to serve the project's projected demand, in addition to the provider's existing commitments?	DEIR Impact UTIL-3, and page 478	No	No	N/A
d) Generate solid waste in excess of State or local standards, or in excess of the capacity of local infrastructure, or otherwise impair the attainment of solid waste reduction goals?	DEIR pages 491-493	No	No	N/A
e) Fail to comply with federal, state, and local management and reduction statutes and regulations related to solid waste?	DEIR pages 491-493	No	No	N/A

## SUMMARY OF EIR ANALYSIS

Impacts from implementation of the Yolo County General Plan are evaluated in the Yolo County General Plan Draft EIR in Chapter IV, Section H, "Utilities and Energy," and are listed below.

- ▶ Result in Increased Demand for Water in Excess of Available Supply. Impact UTIL-1: Build-out of the Draft General Plan may result in a demand for water in excess of available groundwater supply. Even with mitigation, this impact would be significant and unavoidable.
- ▶ Exceed the Capacity of Existing or Planned Water Storage, Conveyance, Distribution, and Treatment Facilities. This impact would be less than significant.
- ▶ Require or Result in Construction of New Water Facilities, or Expansion of Existing Facilities, Resulting in Significant Environmental Effects. This impact would be less than significant.

- ▶ Reduce Groundwater Supplies or Interfere with Groundwater Recharge. Impact UTIL-2: Build-out of the Draft General Plan could result in increased overdraft of County aquifers and a net increase in ground surface subsidence. Even with mitigation, this impact would be significant and unavoidable.
- ▶ Generate Wastewater Flows that Exceed Existing or Planned Treatment Facilities. Impact UTIL-3: Build-out of the Draft General Plan would generate wastewater flows that would exceed the capacities of existing wastewater treatment systems. This impact would be less than significant after mitigation.
- ▶ Result in Significant Impacts from New Wastewater Facilities. This impact would be less than significant.
- ▶ Fail to Meet Wastewater Treatment Requirements of the CVRWQCB. This impact would be less than significant.
- ▶ Exceed the Capacity of Stormwater Drainage Systems. This impact would be less than significant.
- ▶ Substantially Alter Drainage Patterns or Increase the Rate of Runoff. This impact would be less than significant.
- ▶ Environmental Impacts from Construction of New Stormwater Drainage Facilities. This impact would be less than significant.
- ▶ Result in New Solid Waste Disposal Facilities. This impact would be less than significant.
- ▶ Fail to Minimize Waste Streams. This impact would be less than significant.
- ▶ Conflict with Plans and Policies of Other Agencies. This impact would be less than significant.
- ▶ Result in Adverse Impacts from Draft General Plan Policies Compared to 1983 General Plan Policies. This impact would be less than significant.

## CONSISTENCY EVALUATION

Yolo County approved the project through the issuance of a Site Plan Review and NOE, copies of which are included in Appendix A. The Site Plan Review issued for the project identifies the following standard requirements related to utilities and service systems, which are being implemented by the applicant:

- ▶ Submit a Well Permit Application for review and approval prior to construction of any well. The Application will need to be signed by a licensed well driller and the property owner and submitted with a site plan. Wells are to meet setbacks which include 100ft from source of contamination which includes leach fields, wastewater ponds and fuel storage tanks.
- ▶ Only domestic waste, such as restroom and kitchen generated wastewater, is to be discharged into an Onsite Wastewater Treatment System or Septic System. A site evaluation is to be completed to determine an adequate location and size for a primary and future replacement septic system (septic tank and leach field) prior to submittal of a Septic Installation Permit Application. Visit our website or contact our office for more information on requesting a site evaluation.
- ▶ Septic systems are to maintain a setback of 10 ft from a foundation/building and should be protected from vehicle traffic.

Because the project was determined to be consistent with the General Plan, including its land use element, project-related effects related to utilities and service systems would be consistent with and were covered by the analysis and conclusions of the Yolo County General Plan EIR. Further, the project will include a wastewater treatment facility (see Chapter 2, "Project Description," and the hydrology/water quality analysis above). No element of the project would change the conclusions of the Yolo County General Plan EIR or result in new or substantially more severe impacts, and no additional environmental review is needed for the project related to utilities and service systems.

## XX. WILDFIRE

Wildfire was not addressed in the Yolo County General Plan Draft EIR as a separate environmental issue area because such a wildfire analysis was not required at that time. Changes to Appendix G of the State CEQA Guidelines were adopted in December 2018 and wildfire was added as a new resource to be evaluated in CEQA documents. The Yolo County General Plan EIR did evaluate consistency with emergency response and evacuation plans and the impacts related to it, but in the context of hazards and hazardous materials.

Environmental Issue	Where were impacts analyzed previously?	Do proposed changes/new circumstances/ new information result in new significant/ substantially more severe impacts?	Is there substantial new information requiring new analysis or verification?	Do mitigation measures from prior documents resolve significant impacts?
Is the project located in or near state responsibility areas or lands classified as high fire hazard severity zones?				
If located in or near state responsibility areas or lands classified as very high fire hazard severity zones, would the project:				
a) Substantially impair an adopted emergency response plan or emergency evacuation plan?	DEIR Impact HAZ-2	No	No	N/A
b) Due to slope, prevailing winds, and other factors, exacerbate wildfire risks, and thereby expose project occupants to pollutant concentrations from a wildfire or the uncontrolled spread of a wildfire?	DEIR page 726	No	No	N/A
c) Require the installation of associated infrastructure (such as roads, fuel breaks, emergency water sources, power lines or other utilities) that may exacerbate fire risk or that may result in temporary or ongoing impacts to the environment?	Not evaluated	No	No	N/A
d) Expose people or structures to significant risks, including downslope or downstream flooding or landslides, as a result of runoff, post-fire slope instability, or drainage changes?	Not evaluated	No	No	N/A

## SUMMARY OF EIR ANALYSIS

Impacts from implementation of the Yolo County General Plan are evaluated in the Yolo County General Plan Draft EIR in Chapter IV, Section M, "Hazards and Hazardous Materials," and are listed below.

- ▶ Impair Emergency Response or Evacuation Plans Impact HAZ-2: New development under the Draft General Plan may impair emergency response during peak traffic periods. No feasible mitigation is available, and this impact would be significant and unavoidable.
- ▶ Expose People to Fire Risks or Other New Health and Safety Hazards. This impact would be beneficial.

## CONSISTENCY EVALUATION

Yolo County approved the project through the issuance of a Site Plan Review and NOE, copies of which are included in Appendix A. Because the project was determined to be consistent with the General Plan, including its land use element, project-related effects related to wildfire would be consistent with and were covered by the analysis and conclusions of the Yolo County General Plan EIR. No element of the project would change the conclusions of the Yolo County General Plan EIR or result in new or substantially more severe impacts, and no additional environmental review is needed for the project related to wildfire.

This page intentionally left blank.

## 4 CONCLUSION

Based on the foregoing analysis, approval of the project does not require preparation of subsequent or supplemental environmental review documents pursuant to State CEQA Guidelines Section 15162. This addendum pursuant to Section 15164 to evaluate the project is appropriate.

This page intentionally left blank.



## 5 REFERENCES

- Central Valley Regional Water Quality Control Board. 2016 (December). *Central Valley Salt and Nitrate Management Plan Substitute Environmental Documentation*. Prepared for Central Valley Salinity Alternatives for Long-Term Sustainability (CV-SALTS). Prepared by Robertson-Bryan, Inc., Elk Grove, CA. Available: <https://www.cvsalinity.org/resources/basin-planning/>. Accessed February 2024.
- Central Valley RWQCB. *See* Central Valley Regional Water Quality Control Board.
- Yolo County. 2009a. *County of Yolo 2030 Countywide General Plan*. Adopted November 2009; reflects amendments through January 2023. Available: <https://www.yolocounty.org/government/general-government-departments/county-administrator/general-plan/adopted-general-plan>. Accessed February 2024.
- Yolo County. 2009b (April). *Yolo County 2030 Countywide General Plan EIR*. State Clearinghouse No. 2008102034. Available: <https://www.yolocounty.org/government/general-government-departments/county-administrator/general-plan/final-environmental-impact-report-eir>. Accessed February 2024.
- Zamora Pistachio. 2023 (March). *Report of Waste Discharge, Zamora Pistachio, LLC, Zamora, CA Facility*. Prepared by Trinity Consultants, Oakland, CA.

This page intentionally left blank.