

**CALIFORNIA REGIONAL WATER QUALITY CONTROL BOARD  
SAN FRANCISCO BAY REGION**

1515 Clay Street, Suite 1400, Oakland, California 94612  
waterboards.ca.gov/sanfranciscobay

**TENTATIVE ORDER R2-2021-00XX  
NPDES PERMIT CA0038342**

The following Discharger is subject to the waste discharge requirements (WDRs) set forth in this Order:

Discharger **East Bay Municipal Utility District**  
Name of Facility **Orinda Water Treatment Plant**  
Facility Address **190 Camino Pablo  
Orinda, California 94563  
Contra Costa County**

**Table 1. Discharge Location**

<b>Discharge Point</b>	<b>Effluent Description</b>	<b>Discharge Point Latitude (North-South)</b>	<b>Discharge Point Longitude (East-West)</b>	<b>Receiving Water</b>
003	Clarified filter backwash water	37.8945°	-122.2032°	San Pablo Creek

This Order was adopted on:

This Order shall become effective on:

This Order shall expire on:

CIWQS regulatory measure number:

**<Adoption Date>  
September 1, 2021  
August 31, 2026  
<XXXXXX>**

The Discharger shall file a Report of Waste Discharge as an application for updated WDRs in accordance with title 23, California Code of Regulations, and an application for reissuance of a National Pollutant Discharge Elimination System (NPDES) permit no later than **December 4, 2025**. The U.S. Environmental Protection Agency (U.S. EPA) and the California Regional Water Quality Control Board, San Francisco Bay Region (Regional Water Board) have classified this discharge as “**minor**.”

I hereby certify that this Order with all attachments is a full, true, and correct copy of the Order adopted by the Regional Water Board on the date indicated above.

---

Michael Montgomery, Executive Officer

## CONTENTS

1. FACILITY INFORMATION .....	3
2. FINDINGS .....	3
3. DISCHARGE PROHIBITIONS .....	3
4. EFFLUENT LIMITATIONS .....	4
5. RECEIVING WATER LIMITATIONS .....	4
6. PROVISIONS .....	6

## TABLES

TABLE 1. DISCHARGE LOCATION .....	1
TABLE 2. EFFLUENT LIMITATIONS .....	4

## ATTACHMENTS

ATTACHMENT A – DEFINITIONS AND ABBREVIATIONS .....	A-1
ATTACHMENT B – MAPS .....	B-1
ATTACHMENT C – PROCESS FLOW DIAGRAM .....	C-1
ATTACHMENT D – STANDARD PROVISIONS .....	D-1
ATTACHMENT E – MONITORING AND REPORTING PROGRAM .....	E-1
ATTACHMENT F – FACT SHEET .....	F-1
ATTACHMENT G – REGIONAL STANDARD PROVISIONS, AND MONITORING AND REPORTING REQUIREMENTS (SUPPLEMENT TO ATTACHMENT D) .....	G-1

## 1. FACILITY INFORMATION

Information describing the Orinda Water Treatment Plant (Facility) is summarized on the cover page and in Fact Sheet (Attachment F) sections 1 and 2. Fact Sheet section 1 also includes information regarding the permit application.

## 2. FINDINGS

The Regional Water Board finds the following:

- 2.1. Legal Authorities.** This Order serves as WDRs pursuant to California Water Code article 4, chapter 4, division 7 (commencing with § 13260). This Order is also issued pursuant to federal Clean Water Act (CWA) section 402 and implementing regulations adopted by U.S. EPA and Water Code chapter 5.5, division 7 (commencing with § 13370). It shall serve as an NPDES permit authorizing the Discharger to discharge into waters of the United States as described in Table 1 subject to the WDRs in this Order.
- 2.2. Background and Rationale for Requirements.** The Regional Water developed the requirements in this Order based on information the Discharger submitted as part of its application, information obtained through monitoring and reporting programs, and other available information. The Fact Sheet contains background information and rationale for the requirements in this Order and is hereby incorporated into and constitutes findings for this Order. Attachments A through E, and G are also incorporated into this Order.
- 2.3. Notification of Interested Parties.** The Regional Water Board notified the Discharger and interested agencies and persons of its intent to prescribe these WDRs and has provided an opportunity to submit written comments and recommendations. Fact Sheet section 8.1 provides details regarding the notification.
- 2.4. Consideration of Public Comment.** The Regional Water Board, in a public meeting, heard and considered all comments pertaining to the discharge. Fact Sheet section 8.3 provides details regarding the public hearing.

THEREFORE, IT IS HEREBY ORDERED that Order R2-2015-0041 (previous order) is rescinded upon the effective date of this Order, except for enforcement purposes, and, in order to meet the provisions contained in Water Code division 7 (commencing with § 13000) and regulations adopted thereunder and the provisions of the CWA and regulations and guidelines adopted thereunder, the Discharger shall comply with the requirements in this Order. This action in no way prevents the Regional Water Board from taking enforcement action for violations of the previous order.

## 3. DISCHARGE PROHIBITIONS

- 3.1.** Discharge of treated filter backwash water at a location or in a manner different from that described in this Order is prohibited.

3.2. Bypassing settling basins is prohibited, except as provided for in Attachment D, section 1.7, of this Order.

#### 4. EFFLUENT LIMITATIONS

4.1. **Effluent Limitations.** The discharge at Discharge Point 003 shall meet the following effluent limitations, with compliance measured at Monitoring Location EFF-003 as described in the Monitoring and Reporting Program (MRP):

**Table 2. Effluent Limitations**

Parameter	Units	Average Monthly	Average Weekly	Maximum Daily	Instantaneous Minimum	Instantaneous Maximum
Total Suspended Solids (TSS)	mg/L	30	45	-	-	-
Settleable Matter	mL/L-hr	0.1	-	0.2	-	-
pH <sup>[1]</sup>	standard units	-	-	-	6.5	8.5
Chlorine, Total Residual <sup>[2]</sup>	mg/L	-	-	-	-	0.0
Dichlorobromomethane	µg/L	3.2	-	4.4	-	-

Footnote:

<sup>[1]</sup> If the Discharger monitors pH continuously, pursuant to 40 C.F.R. section 401.17 the Discharger shall be in compliance with this pH limitation provided that both of the following conditions are satisfied: (i) the total time during which the pH is outside the required range shall not exceed 7 hours and 26 minutes in any calendar month; and (ii) no individual excursion from the required pH range shall exceed 60 minutes.

<sup>[2]</sup> The Discharger shall calibrate and maintain total residual chlorine field test kits and analyzers (U.S. EPA-approved Standard Methods 4500-Cl F and G) to reliably quantify values of 0.1 mg/L and greater. This 0.1 mg/L concentration shall be the minimum level (ML) for total residual chlorine; this ML shall also be the reporting limit (RL).

4.2. **Acute Toxicity.** The discharge at Discharge Point 003 shall meet the following acute toxicity effluent limitations, with compliance measured at Monitoring Location EFF-003 as described in the MRP:

4.2.1. The 3-sample median shall not exhibit less than 90 percent survival (i.e., a bioassay showing less than 90 percent survival shall represent a violation of this effluent limit if one or more of the past two bioassay tests show less than 90 percent survival); and

4.2.2 A single-sample shall not exhibit less than 70 percent survival (i.e., a bioassay showing less than 70 percent survival shall represent a violation of this effluent limit).

#### 5. RECEIVING WATER LIMITATIONS

5.1. The discharge shall not cause the following conditions at any place in receiving waters:

5.1.1. Floating material, including solids, liquids, foams, and scum, in concentrations that cause nuisance or adversely affect beneficial uses;

- 5.1.2. Alteration of suspended sediment in such a manner as to cause nuisance or adversely affect beneficial uses or detrimental increase in the concentrations of toxic pollutants in sediments or aquatic life;
- 5.1.3. Suspended material in concentrations that cause nuisance or adversely affect beneficial uses;
- 5.1.4. Bottom deposits or aquatic growths to the extent that such deposits or growths cause nuisance or adversely affect beneficial uses;
- 5.1.5. Alteration of temperature beyond present natural background levels unless it can be demonstrated to the satisfaction of the Regional Water Board that such alteration in temperature does not adversely affect beneficial uses;
- 5.1.6. Changes in turbidity that cause nuisance or adversely affect beneficial uses, or increases from normal background light penetration or turbidity greater than 10 percent in areas where natural turbidity is greater than 50 nephelometric turbidity units, or above 55 nephelometric turbidity units in areas where natural turbidity is less than or equal to 50 nephelometric turbidity units;
- 5.1.7. Coloration that causes nuisance or adversely affects beneficial uses;
- 5.1.8. Visible, floating, suspended, or deposited oil or other products of petroleum origin; or
- 5.1.9. Toxic or other deleterious substances in concentrations or quantities that cause deleterious effects on wildlife, waterfowl, or other aquatic biota, or render any of these unfit for human consumption, either at levels created in the receiving waters or as a result of biological concentration.

**5.2.** The discharge shall not cause the following limits to be exceeded at any place in receiving waters within one foot of the water surface:

- 5.2.1. Dissolved Oxygen     7.0 mg/L, minimum  

The median dissolved oxygen concentration for any three consecutive months shall not be less than 80 percent of the dissolved oxygen content at saturation. When natural factors cause concentrations less than that specified above, the discharge shall not cause further reduction in ambient dissolved oxygen concentrations
- 5.2.2. Dissolved Sulfide     Natural background levels
- 5.2.3. pH     The pH shall not be depressed below 6.5 nor raised above 8.5. The discharge shall not cause changes greater than 0.5 pH units in normal ambient pH levels.

5.2.4. Nutrients Waters shall not contain biostimulatory substances in concentrations that promote aquatic growths to the extent that such growths cause nuisance or adversely affect beneficial uses.

5.3. The discharge shall not cause a violation of any water quality standard for receiving waters adopted by the Regional Water Board or State Water Resources Control Board (State Water Board) as required by the CWA and regulations adopted thereunder beyond any mixing zone established through this Order. If more stringent water quality standards are promulgated or approved pursuant to CWA section 303, or amendments thereto, the Regional Water Board may revise or modify this Order in accordance with the more stringent standards.

## 6. PROVISIONS

### 6.1. Standard Provisions

- 6.1.1. The Discharger shall comply with all “Standard Provisions” in Attachment D.
- 6.1.2. The Discharger shall comply with all applicable provisions of the “Regional Standard Provisions, and Monitoring and Reporting Requirements for NPDES Wastewater Discharge Permits” in Attachment G.
- 6.1.3. If there is any conflict, duplication, or overlap between provisions in this Order, the more stringent provision shall apply.

### 6.2. Monitoring and Reporting Provisions

The Discharger shall comply with the Monitoring and Reporting Program (MRP, Attachment E) and future revisions thereto, and applicable monitoring and reporting requirements in Attachments D and G.

### 6.3. Special Provisions

#### 6.3.1. Reopener Provisions

The Regional Water Board may modify or reopen this Order prior to its expiration date in any of the following circumstances as allowed by law or as otherwise authorized by law. The Discharger may request a permit modification based on any of these circumstances. With any such request, the Discharger shall include antidegradation and anti-backsliding analyses as necessary.

- 6.3.1.1. If present or future investigations demonstrate that the discharges governed by this Order have or will have a reasonable potential to cause or contribute to adverse impacts on water quality or beneficial uses of the receiving waters;

- 6.3.1.2. If new or revised water quality objectives or total maximum daily loads (TMDLs) come into effect for San Francisco Bay or contiguous water bodies (whether statewide, regional, or site-specific). In such cases, effluent limitations in this Order may be modified as necessary to reflect the updated water quality objectives or wasteload allocations. Adoption of the effluent limitations in this Order is not intended to restrict in any way future modifications based on legally-adopted water quality objectives or TMDLs or as otherwise permitted under federal regulations governing NPDES permit modifications;
- 6.3.1.3. If translator, dilution, or other water quality studies provide a basis for determining that a permit condition should be modified;
- 6.3.1.4. If a State Water Board precedential decision, new policy, new law, or new regulation is adopted; or
- 6.3.1.5. If an administrative or judicial decision on a separate NPDES permit or WDRs addresses requirements similar to this discharge,

**6.3.2. Best Management Practices (BMPs) Plan**

The Discharger shall (1) continue to implement its BMPs Plan, (2) review and update the effectiveness and adequacy of the implemented BMPs Plan annually, or more often as necessary, and (3) report to the Regional Water Board a summary of the review and update in the annual self-monitoring report required by the MRP. The BMPs Plan shall address all specific means of controlling the discharge of pollutants from the Facility.

## ATTACHMENT A – DEFINITIONS AND ABBREVIATIONS

### DEFINITIONS

#### **Arithmetic Mean ( $\mu$ )**

Also called the average, sum of measured values divided by the number of samples. For ambient water concentrations, the arithmetic mean is calculated as follows:

$$\text{Arithmetic mean} = \mu = \Sigma x / n$$

where:  $\Sigma x$  is the sum of the measured ambient water concentrations,  
and  $n$  is the number of samples

#### **Average Monthly Effluent Limitation (AMEL)**

Highest allowable average of daily discharges over a calendar month, calculated as the sum of all daily discharges measured during a calendar month divided by the number of daily discharges measured during that month.

#### **Average Weekly Effluent Limitation (AWEL)**

Highest allowable average of daily discharges over a calendar week (Sunday through Saturday), calculated as the sum of all daily discharges measured during a calendar week divided by the number of daily discharges measured during that week.

#### **Bioaccumulative**

Taken up by an organism from its surrounding medium through gill membranes, through epithelial tissue, or from food and subsequently concentrated and retained in the body of the organism.

#### **Carcinogenic**

Known to cause cancer in living organisms.

#### **Coefficient of Variation (CV)**

Measure of data variability calculated as the estimated standard deviation divided by the arithmetic mean of the observed values.

#### **Daily Discharge**

Either: (1) the total mass of a constituent discharged over a calendar day (12:00 a.m. through 11:59 p.m.) or any 24-hour period that reasonably represents a calendar day for purposes of sampling (as specified in the permit) for a constituent with limitations expressed in units of mass; or (2) the unweighted arithmetic mean measurement of a constituent over a day for a constituent with limitations expressed in other units of measurement (e.g., concentration).

The daily discharge may be determined by the analytical results of a composite sample taken over the course of one day (a calendar day or other 24-hour period defined as a day) or by the arithmetic mean of analytical results from one or more grab samples taken over the course of the day.



For composite sampling, if 1 day is defined as a 24-hour period other than a calendar day, the analytical result for the 24-hour period is considered the result for the calendar day in which the 24-hour period ends.

### **Detected, but Not Quantified (DNQ)**

Sample results less than the RL, but greater than or equal to the laboratory's MDL. Sample results reported as DNQ are estimated concentrations.

### **Dilution Credit**

Amount of dilution granted to a discharge in the calculation of a water quality-based effluent limitation, based on the allowance of a specified mixing zone. It is calculated from the dilution ratio or determined through conducting a mixing zone study or modeling of the discharge and receiving water.

### **Effluent Concentration Allowance (ECA)**

Value derived from the water quality criterion or objective, dilution credit, and ambient background concentration that is used, in conjunction with the CV for the effluent monitoring data, to calculate a long-term average (LTA) discharge concentration. The ECA has the same meaning as wasteload allocation (WLA) as used in U.S. EPA guidance (*Technical Support Document for Water Quality-based Toxics Control*, March 1991, second printing, EPA/505/2-90-001).

### **Enclosed Bays**

Indentations along the coast that enclose an area of oceanic water within distinct headlands or harbor works. Enclosed bays include all bays where the narrowest distance between the headlands or outermost harbor works is less than 75 percent of the greatest dimension of the enclosed portion of the bay. Enclosed bays include, but are not limited to, Humboldt Bay, Bodega Harbor, Tomales Bay, Drake's Estero, San Francisco Bay, Morro Bay, Los Angeles-Long Beach Harbor, Upper and Lower Newport Bay, Mission Bay, and San Diego Bay. Enclosed bays do not include inland surface waters or ocean waters.

### **Estimated Chemical Concentration**

Concentration that results from the confirmed detection of a substance below the ML by the analytical method.

### **Estuaries**

Waters, including coastal lagoons, located at the mouths of streams that serve as areas of mixing for fresh and ocean waters. Coastal lagoons and mouths of streams that are temporarily separated from the ocean by sandbars shall be considered estuaries. Estuarine waters are considered to extend from a bay or the open ocean to a point upstream where there is no significant mixing of fresh water and seawater. Estuarine waters included, but are not limited to, the Sacramento-San Joaquin Delta, as defined in Water Code section 12220; Suisun Bay; Carquinez Strait downstream to the Carquinez Bridge; and appropriate areas of the Smith, Mad, Eel, Noyo, Russian, Klamath, San Diego, and Otay rivers. Estuaries do not include inland surface waters or ocean waters.

### **Inland Surface Waters**

All surface waters of the state that are not the ocean, enclosed bays, or estuaries.

### **Instantaneous Maximum Effluent Limitation**

Highest allowable value for any single grab sample or aliquot (i.e., each grab sample or aliquot is independently compared to the instantaneous maximum limitation).

### **Instantaneous Minimum Effluent Limitation**

Lowest allowable value for any single grab sample or aliquot (i.e., each grab sample or aliquot is independently compared to the instantaneous minimum limitation).

### **Maximum Daily Effluent Limitation (MDEL)**

Highest allowable daily discharge of a pollutant, over a calendar day (or 24-hour period). For pollutants with limitations expressed in units of mass, the daily discharge is calculated as the total mass of the pollutant discharged over the day. For pollutants with limitations expressed in other units of measurement, the daily discharge is calculated as the arithmetic mean measurement of the pollutant over the day.

### **Median**

Middle measurement in a data set. The median of a data set is found by first arranging the measurements in order of magnitude (either increasing or decreasing order). If the number of measurements ( $n$ ) is odd, then the median =  $X_{(n+1)/2}$ . If  $n$  is even, then the median =  $(X_{n/2} + X_{(n/2+1)})/2$  (i.e., the midpoint between  $n/2$  and  $n/2+1$ ).

### **Method Detection Limit (MDL)**

Minimum concentration of a substance that can be reported with 99 percent confidence that the measured concentration is distinguishable from method blank results, as defined in 40 C.F.R. part 136, Appendix B.

### **Minimum Level (ML)**

Concentration at which the entire analytical system must give a recognizable signal and acceptable calibration point. The ML is the concentration in a sample that is equivalent to the concentration of the lowest calibration standard analyzed by a specific analytical procedure, assuming that all the method specified sample weights, volumes, and processing steps have been followed.

### **Mixing Zone**

Limited volume of receiving water allocated for mixing with a wastewater discharge where water quality criteria can be exceeded without causing adverse effects to the overall water body.

### **Not Detected (ND)**

Sample results less than the laboratory's MDL.

### **Persistent Pollutants**

Substances for which degradation or decomposition in the environment is nonexistent or very slow.

### **Pollutant Minimization Program**

Program of waste minimization and pollution prevention actions that include, but are not limited to, product substitution, waste stream recycling, alternative waste management methods, and education of the public and businesses. The goal of a Pollutant Minimization Program is to reduce all potential sources of a priority pollutant through pollutant minimization (control) strategies, including pollution prevention measures as appropriate, to maintain the effluent concentration at or below the water quality-based effluent limitation. Pollution prevention measures may be particularly appropriate for persistent bioaccumulative priority pollutants where there is evidence that beneficial uses are being impacted. Cost effectiveness may be considered when establishing the requirements of a Pollutant Minimization Program. The completion and implementation of a Pollution Prevention Plan, if required pursuant to Water Code section 13263.3(d), is considered to fulfill the Pollutant Minimization Program requirements.

### **Pollution Prevention**

Any action that causes a net reduction in the use or generation of a hazardous substance or other pollutant discharged into water and includes, but is not limited to, input change, operational improvement, production process change, and product reformulation (as defined in Water Code section 13263.3). Pollution prevention does not include actions that merely shift a pollutant in wastewater from one environmental medium to another environmental medium, unless clear environmental benefits of such an approach are identified to the satisfaction of the State Water Resources Control Board or Regional Water Board.

### **Reporting Level (RL)**

ML (and its associated analytical method) chosen by the Discharger for reporting and compliance determination from the MLs included in this Order, including an additional factor if applicable as discussed herein. For priority pollutants, the MLs included in this Order correspond to approved analytical methods for reporting a sample result that are selected by the Regional Water Board either from State Implementation Plan (SIP) Appendix 4 in accordance with SIP section 2.4.2 or established in accordance with SIP section 2.4.3. The ML is based on the proper application of method-based analytical procedures for sample preparation and the absence of any matrix interferences. Other factors may be applied to the ML depending on the specific sample preparation steps employed. For example, the treatment typically applied in cases where there are matrix-effects is to dilute the sample or sample aliquot by a factor of ten. In such cases, this additional factor must be applied to the ML in the computation of the RL.

### **Source of Drinking Water**

Any water designated as municipal or domestic supply (MUN) beneficial use.

### **Standard Deviation ( $\sigma$ )**

Measure of variability calculated as follows:

$$\text{Standard deviation} = \sigma = (\sum[(x - \mu)^2]/(n - 1))^{0.5}$$

where:  $x$  is the observed value  
 $\mu$  is the arithmetic mean of the observed values  
 $n$  is the number of samples

### **Toxicity Reduction Evaluation (TRE)**

Study conducted in a step-wise process designed to identify the causative agents of effluent or ambient toxicity, isolate the sources of toxicity, evaluate the effectiveness of toxicity control options, and then confirm the reduction in toxicity. The first steps of the TRE consist of the collection of data relevant to the toxicity, including additional toxicity testing, and an evaluation of facility operations and maintenance practices, and best management practices. A Toxicity Identification Evaluation (TIE) may be required as part of the TRE, if appropriate. A TIE is a set of procedures to identify the specific chemicals responsible for toxicity. These procedures are performed in three phases (characterization, identification, and confirmation) using aquatic organism toxicity tests.

### **ABBREVIATIONS**

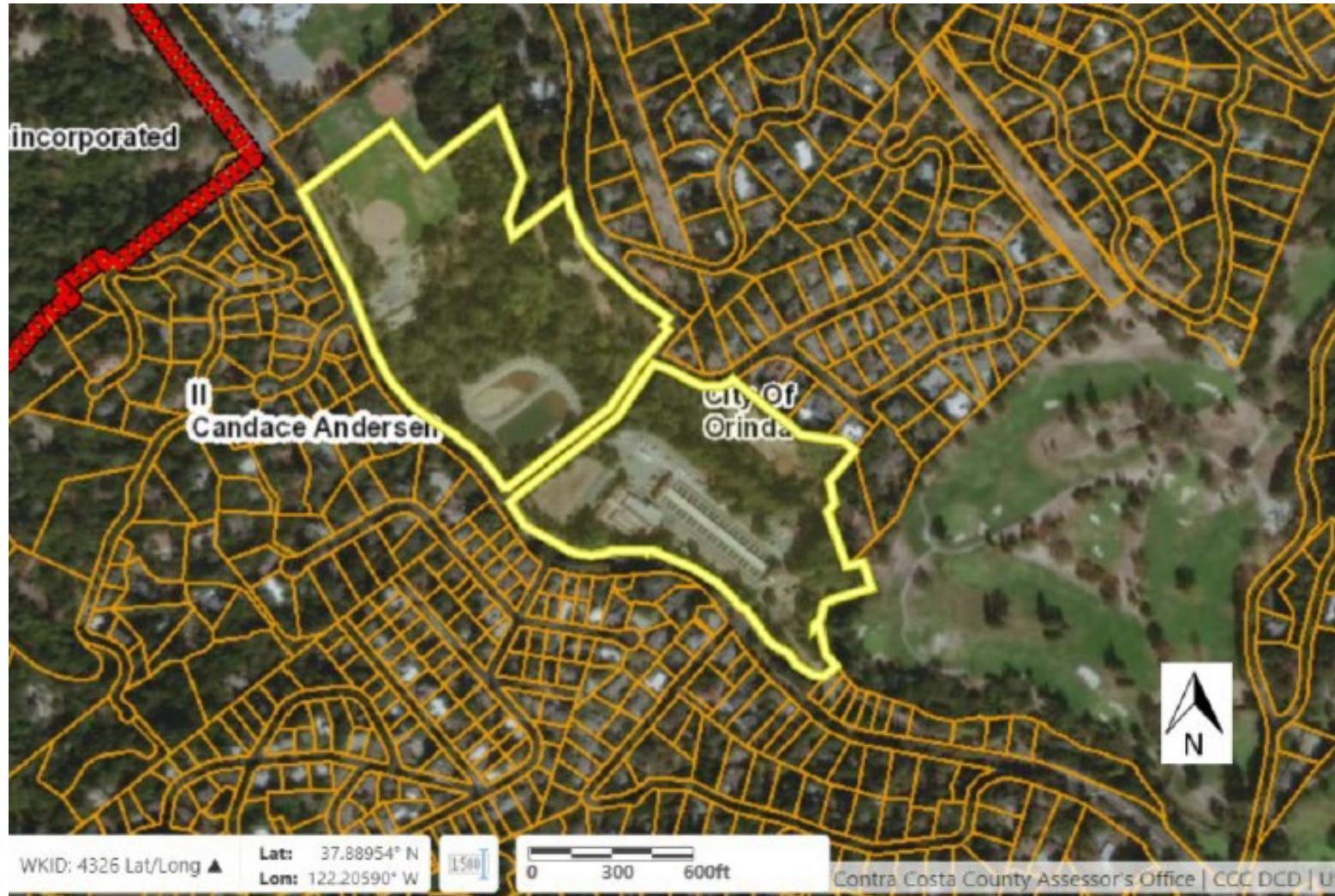
<b>%</b>	Percent
<b>µg/L</b>	Micrograms per liter
<b>1/Blending Event</b>	Once per blending event
<b>1/Day</b>	Once per day
<b>1/Month</b>	Once per month
<b>1/Quarter</b>	Once per quarter
<b>1/Week</b>	Once per week
<b>1/Year</b>	Once per year
<b>2/Month</b>	Two times per month
<b>2/Week</b>	Twice per week
<b>2/Year</b>	Twice per year
<b>3/Week</b>	Three times per week
<b>4/Week</b>	Four times per week
<b>5/Week</b>	Five times per week
<b>AMEL</b>	Average monthly effluent limitation
<b>AWEL</b>	Average weekly effluent limitation
<b>B</b>	Background concentration
<b>C</b>	Water quality criterion or objective
<b>C-24</b>	24-hour composite
<b>CFU/100 mL</b>	Colony forming units per 100 milliliters
<b>CIWQS</b>	California Integrated Water Quality System

<b>Continuous</b>	Measured continuously
<b>Continuous/D</b>	Measured continuously, and recorded and reported daily
<b>Continuous/H</b>	Measured continuously, and recorded and reported hourly
<b>CTR</b>	California Toxics Rule
<b>CV</b>	Coefficient of Variation
<b>DMR</b>	Discharge Monitoring Report
<b>DNQ</b>	Detected, but not quantified
<b>DL</b>	Detection level
<b>ECA</b>	Effluent Concentration Allowance
<b>Grab</b>	Grab sample
<b>MDEL</b>	Maximum Daily Effluent Limitation
<b>MDL</b>	Method detection limit
<b>MEC</b>	Maximum effluent concentration
<b>MG</b>	Million gallons
<b>mg/L</b>	Milligrams per liter
<b>mg/L as N</b>	Milligrams per liter as nitrogen
<b>MGD</b>	Million gallons per day
<b>ML</b>	Minimum level
<b>mL/L-hr</b>	Milliliters per liter per hour
<b>MPN/100 mL</b>	Most probable number per 100 milliliters
<b>NTR</b>	National Toxics Rule
<b>ND</b>	Not detected
<b>NTU</b>	Nephelometric turbidity units
<b>RL</b>	Reporting level
<b>RPA</b>	Reasonable potential analysis
<b>SIP</b>	<i>Policy for Implementation of Toxics Standards for Inland Surface Waters, Enclosed Bays, and Estuaries of California</i> (State Implementation Policy)
<b>SMR</b>	Self Monitoring Report
<b>s.u.</b>	Standard pH units
<b>TIE</b>	Toxicity identification evaluation
<b>TRE</b>	Toxicity reduction evaluation
<b>TUa</b>	Acute toxicity units

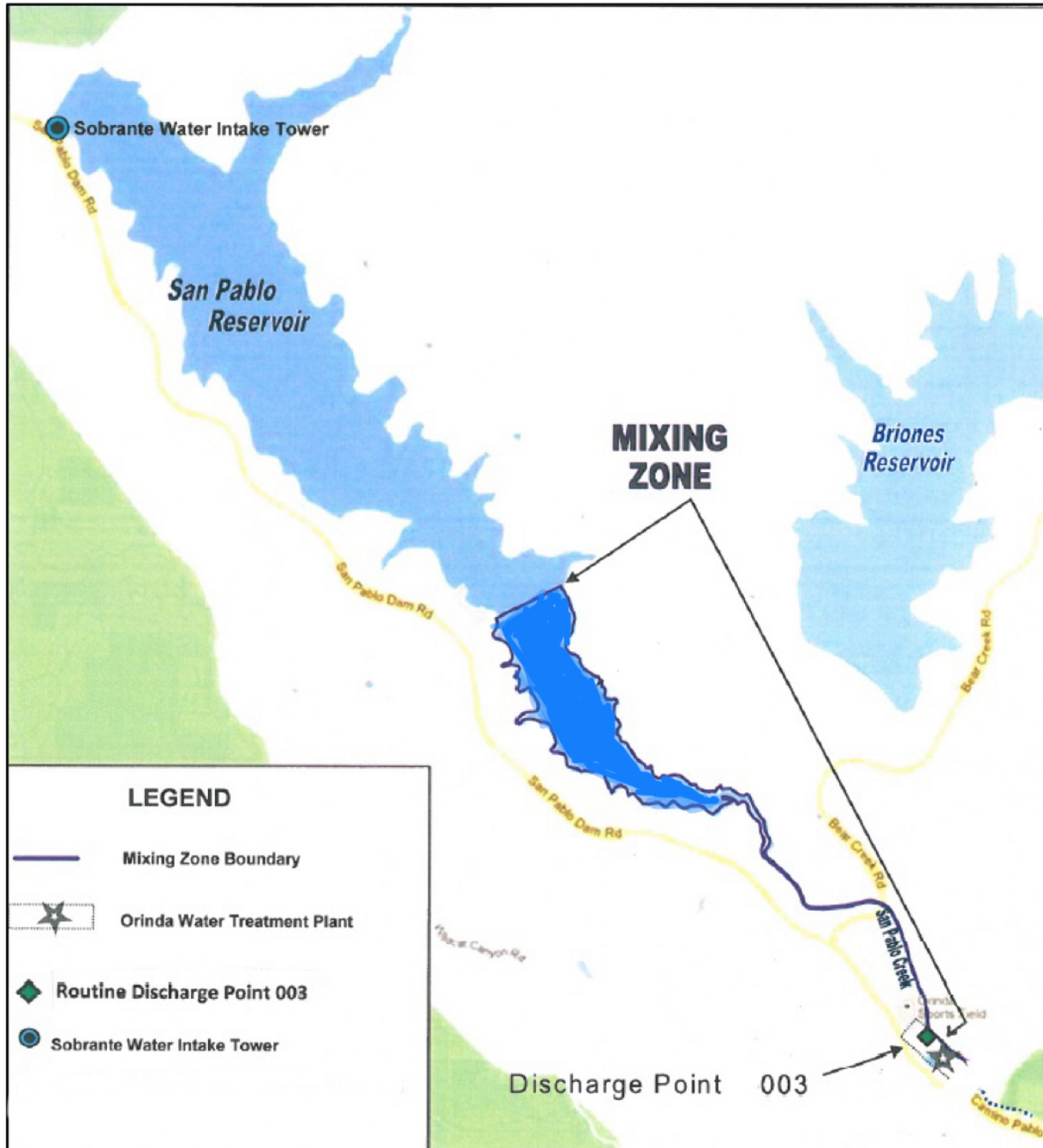
<b>TUc</b>	Chronic toxicity units
<b>WDRs</b>	Waste discharge requirements
<b>WQBEL</b>	Water quality-based effluent limitation

### ATTACHMENT B – MAPS

Figure B-1. Facility Satellite Image

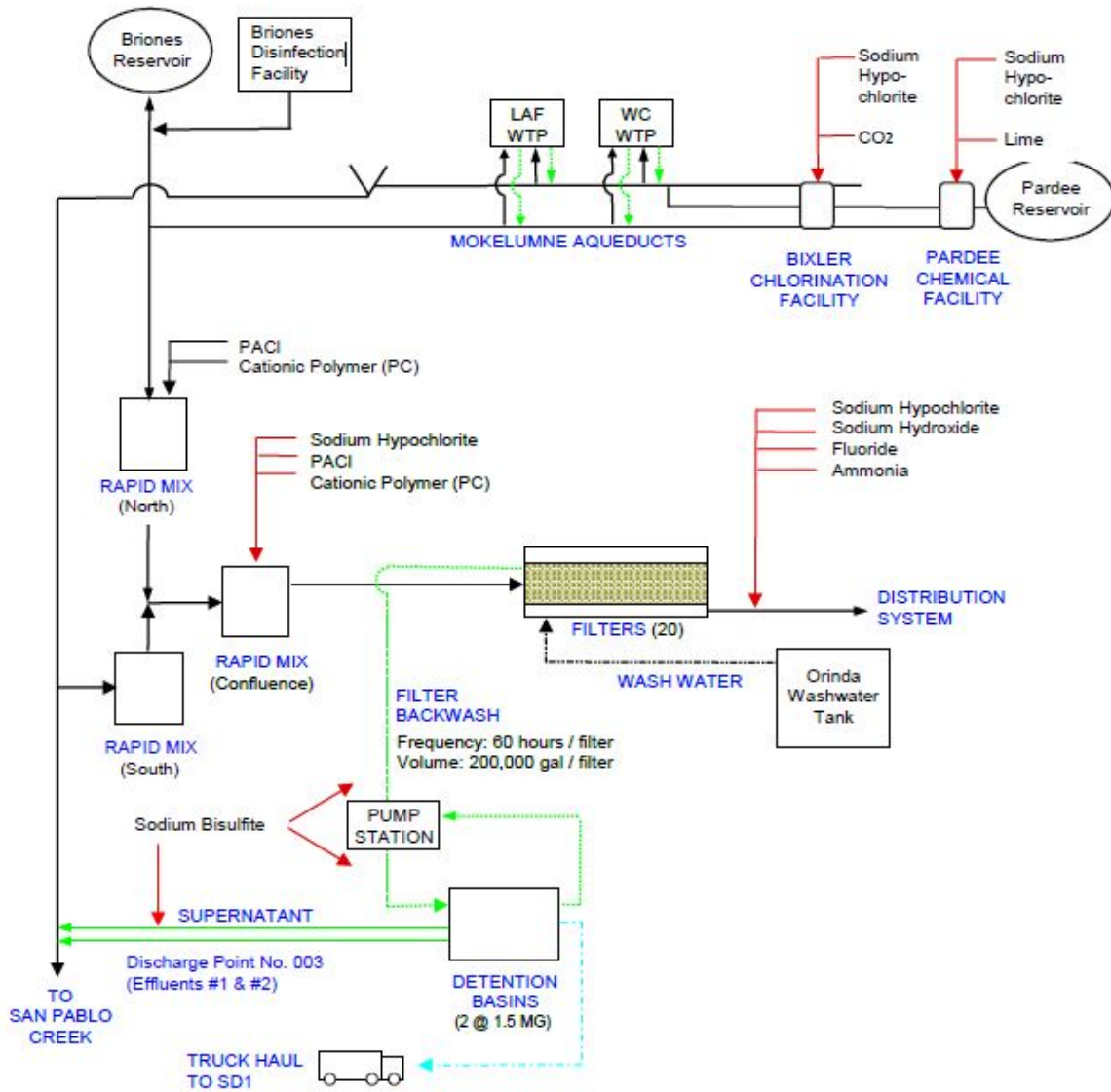


**Figure B-2. Facility Discharge Location and Mixing Zone**





### ATTACHMENT C – PROCESS FLOW DIAGRAM



KEY	
—	Gravity Flow
.....	Gravity/ Pumped Flow Combination
.....	Pumped Flow
PC -	Coagulant Polymer
PT -	Treatment Polymer
PS -	Solids Polymer
PACI -	Polyaluminum Chloride

## ATTACHMENT D – STANDARD PROVISIONS

### CONTENTS

1.	STANDARD PROVISIONS – PERMIT COMPLIANCE .....	D-2
2.	STANDARD PROVISIONS – PERMIT ACTION .....	D-5
3.	STANDARD PROVISIONS – MONITORING .....	D-6
4.	STANDARD PROVISIONS – RECORDS .....	D-6
5.	STANDARD PROVISIONS – REPORTING .....	D-7
6.	STANDARD PROVISIONS – ENFORCEMENT .....	D-12
7.	ADDITIONAL PROVISIONS – NOTIFICATION LEVELS .....	D-12

## ATTACHMENT D – STANDARD PROVISIONS

### 1. STANDARD PROVISIONS – PERMIT COMPLIANCE

#### 1.1. Duty to Comply

- 1.1.1. The Discharger must comply with all of the terms, requirements, and conditions of this Order. Any noncompliance constitutes a violation of the Clean Water Act (CWA) and the California Water Code and is grounds for enforcement action; permit termination, revocation and reissuance, or modification; denial of a permit renewal application; or a combination thereof. (40 C.F.R. § 122.41(a); Wat. Code, §§ 13261, 13263, 13265, 13268, 13000, 13001, 13304, 13350, 13385.)
- 1.1.2. The Discharger shall comply with effluent standards or prohibitions established under CWA section 307(a) for toxic pollutants within the time provided in the regulations that establish these standards or prohibitions, even if this Order has not yet been modified to incorporate the requirement. (40 C.F.R. § 122.41(a)(1).)

**1.2. Need to Halt or Reduce Activity Not a Defense.** It shall not be a defense for a Discharger in an enforcement action that it would have been necessary to halt or reduce the permitted activity in order to maintain compliance with the conditions of this Order. (40 C.F.R. § 122.41(c).)

**1.3. Duty to Mitigate.** The Discharger shall take all reasonable steps to minimize or prevent any discharge in violation of this Order that has a reasonable likelihood of adversely affecting human health or the environment. (40 C.F.R. § 122.41(d).)

**1.4. Proper Operation and Maintenance.** The Discharger shall at all times properly operate and maintain all facilities and systems of treatment and control (and related appurtenances) that are installed or used by the Discharger to achieve compliance with the conditions of this Order. Proper operation and maintenance also includes adequate laboratory controls and appropriate quality assurance procedures. This provision requires the operation of backup or auxiliary facilities or similar systems that are installed by a Discharger only when necessary to achieve compliance with the conditions of this Order. (40 C.F.R. § 122.41(e).)

#### 1.5. Property Rights

- 1.5.1. This Order does not convey any property rights of any sort or any exclusive privileges. (40 C.F.R. § 122.41(g).)
- 1.5.2. The issuance of this Order does not authorize any injury to persons or property or invasion of other private rights, or any infringement of state or local law or regulations. (40 C.F.R. § 122.5(c).)

- 1.6. Inspection and Entry.** The Discharger shall allow the Regional Water Board, State Water Board, U.S. EPA, and/or their authorized representatives (including an authorized contractor acting as their representative), upon the presentation of credentials and other documents, as may be required by law, to (33 U.S.C. § 1318(a)(4)(B); 40 C.F.R. § 122.41(i); Wat. Code, §§ 13267, 13383):
- 1.6.1. Enter upon the Discharger's premises where a regulated facility or activity is located or conducted, or where records are kept under the conditions of this Order (33 U.S.C. § 1318(a)(4)(B)(i); 40 C.F.R. § 122.41(i)(1); Wat. Code, §§ 13267, 13383);
  - 1.6.2. Have access to and copy, at reasonable times, any records that must be kept under the conditions of this Order (33 U.S.C. § 1318(a)(4)(B)(ii); 40 C.F.R. § 122.41(i)(2); Wat. Code, §§ 13267, 13383);
  - 1.6.3. Inspect and photograph, at reasonable times, any facilities, equipment (including monitoring and control equipment), practices, or operations regulated or required under this Order (33 U.S.C. § 1318(a)(4)(B)(ii); 40 C.F.R. § 122.41(i)(3); Wat. Code, §§ 13267, 13383); and
  - 1.6.4. Sample or monitor, at reasonable times, for the purposes of ensuring Order compliance or as otherwise authorized by the CWA or the Water Code, any substances or parameters at any location. (33 U.S.C. § 1318(a)(4)(B); 40 C.F.R. § 122.41(i)(4); Wat. Code, §§ 13267, 13383.)

## 1.7. Bypass

### 1.7.1. Definitions

- 1.7.1.1. "Bypass" means the intentional diversion of waste streams from any portion of a treatment facility. (40 C.F.R. § 122.41(m)(1)(i).)
- 1.7.1.2. "Severe property damage" means substantial physical damage to property; damage to the treatment facilities, which causes them to become inoperable; or substantial and permanent loss of natural resources that can reasonably be expected to occur in the absence of a bypass. Severe property damage does not mean economic loss caused by delays in production. (40 C.F.R. § 122.41(m)(1)(ii).)

- 1.7.2. **Bypass not exceeding limitations.** The Discharger may allow any bypass to occur that does not cause exceedances of effluent limitations, but only if it is for essential maintenance to ensure efficient operation. These bypasses are not subject to the provisions listed in Standard Provisions – Permit Compliance sections 1.7.3, 1.7.4, and 1.7.5 below. (40 C.F.R. § 122.41(m)(2).)

- 1.7.3. **Prohibition of bypass.** Bypass is prohibited, and the Regional Water Board may take enforcement action against a Discharger for bypass, unless (40 C.F.R. § 122.41(m)(4)(i)):

- 1.7.3.1. Bypass was unavoidable to prevent loss of life, personal injury, or severe property damage (40 C.F.R. § 122.41(m)(4)(i)(A));
- 1.7.3.2. There were no feasible alternatives to the bypass, such as the use of auxiliary treatment facilities, retention of untreated wastes, or maintenance during normal periods of equipment downtime. This condition is not satisfied if adequate back up equipment should have been installed in the exercise of reasonable engineering judgment to prevent a bypass that occurred during normal periods of equipment downtime or preventive maintenance (40 C.F.R. § 122.41(m)(4)(i)(B)); and
- 1.7.3.3. The Discharger submitted notice to the Regional Water Board as required under Standard Provisions – Permit Compliance section 1.7.5 below. (40 C.F.R. § 122.41(m)(4)(i)(C).)
- 1.7.4. **Approval.** The Regional Water Board may approve an anticipated bypass, after considering its adverse effects, if the Regional Water Board determines that it will meet the three conditions listed in Standard Provisions – Permit Compliance section 1.7.3 above. (40 C.F.R. § 122.41(m)(4)(ii).)
- 1.7.5. **Notice**
  - 1.7.5.1. **Anticipated bypass.** If the Discharger knows in advance of the need for a bypass, it shall submit prior notice, if possible, at least 10 days before the date of the bypass. The notice shall be sent to the Regional Water Board. As of December 21, 2025, a notice shall also be submitted electronically to the initial recipient defined in Standard Provisions – Reporting section 5.10 below. Notices shall comply with 40 C.F.R. part 3, 40 C.F.R. section 122.22, and 40 C.F.R. part 127. (40 C.F.R. § 122.41(m)(3)(i).)
  - 1.7.5.2. **Unanticipated bypass.** The Discharger shall submit a notice of an unanticipated bypass as required in Standard Provisions – Reporting section 5.5 below (24-hour notice). The notice shall be sent to the Regional Water Board. As of December 21, 2025, a notice shall also be submitted electronically to the initial recipient defined in Standard Provisions – Reporting section 5.10 below. Notices shall comply with 40 C.F.R. part 3, 40 C.F.R. section 122.22, and 40 C.F.R. part 127. (40 C.F.R. § 122.41(m)(3)(ii).)
- 1.8. **Upset.** Upset means an exceptional incident in which there is unintentional and temporary noncompliance with technology-based permit effluent limitations because of factors beyond the reasonable control of the Discharger. An upset does not include noncompliance to the extent caused by operational error, improperly designed treatment facilities, inadequate treatment facilities, lack of preventive maintenance, or careless or improper operation. (40 C.F.R. § 122.41(n)(1).)

- 1.8.1. **Effect of an upset.** An upset constitutes an affirmative defense to an action brought for noncompliance with such technology-based permit effluent limitations if the requirements of Standard Provisions – Permit Compliance section 1.8.2 below are met. No determination made during administrative review of claims that noncompliance was caused by upset, and before an action for noncompliance, is final administrative action subject to judicial review. (40 C.F.R. § 122.41(n)(2).)
- 1.8.2. **Conditions necessary for a demonstration of upset.** A Discharger who wishes to establish the affirmative defense of upset shall demonstrate, through properly signed, contemporaneous operating logs or other relevant evidence that (40 C.F.R. § 122.41(n)(3)):
  - 1.8.2.1. An upset occurred and that the Discharger can identify the cause(s) of the upset (40 C.F.R. § 122.41(n)(3)(i));
  - 1.8.2.2. The permitted facility was, at the time, being properly operated (40 C.F.R. § 122.41(n)(3)(ii));
  - 1.8.2.3. The Discharger submitted notice of the upset as required in Standard Provisions – Reporting section 5.5.2.2 below (24-hour notice) (40 C.F.R. § 122.41(n)(3)(iii)); and
  - 1.8.2.4. The Discharger complied with any remedial measures required under Standard Provisions – Permit Compliance section 1.3 above. (40 C.F.R. § 122.41(n)(3)(iv).)
- 1.8.3. **Burden of proof.** In any enforcement proceeding, the Discharger seeking to establish the occurrence of an upset has the burden of proof. (40 C.F.R. § 122.41(n)(4).)

## 2. STANDARD PROVISIONS – PERMIT ACTION

- 2.1. **General.** This Order may be modified, revoked and reissued, or terminated for cause. The filing of a request by the Discharger for modification, revocation and reissuance, or termination, or a notification of planned changes or anticipated noncompliance does not stay any Order condition. (40 C.F.R. § 122.41(f).)
- 2.2. **Duty to Reapply.** If the Discharger wishes to continue an activity regulated by this Order after the expiration date of this Order, the Discharger must apply for and obtain a new permit. (40 C.F.R. § 122.41(b).)
- 2.3. **Transfers.** This Order is not transferable to any person except after notice to the Regional Water Board. The Regional Water Board may require modification or revocation and reissuance of the Order to change the name of the Discharger and incorporate such other requirements as may be necessary under the CWA and Water Code. (40 C.F.R. §§ 122.41(l)(3), 122.61.)

### **3. STANDARD PROVISIONS – MONITORING**

- 3.1. Samples and measurements taken for the purpose of monitoring shall be representative of the monitored activity. (40 C.F.R. § 122.41(j)(1).)
- 3.2. Monitoring must be conducted according to test procedures approved under 40 C.F.R. part 136 for the analyses of pollutants unless another method is required under 40 C.F.R. chapter 1, subchapter N. Monitoring must be conducted according to sufficiently sensitive test methods approved under 40 C.F.R. part 136 for the analysis of pollutants or pollutant parameters or as required under 40 C.F.R. chapter 1, subchapter N. For the purposes of this paragraph, a method is sufficiently sensitive when:
  - 3.2.1. The method minimum level (ML) is at or below the level of the most stringent effluent limitation established in the permit for the measured pollutant or pollutant parameter, and either the method ML is at or below the level of the most stringent applicable water quality criterion for the measured pollutant or pollutant parameter or the method ML is above the applicable water quality criterion but the amount of the pollutant or pollutant parameter in the facility's discharge is high enough that the method detects and quantifies the level of the pollutant or pollutant parameter in the discharge; or
  - 3.2.2. The method has the lowest ML of the analytical methods approved under 40 C.F.R. part 136 or required under 40 C.F.R. chapter 1, subchapter N, for the measured pollutant or pollutant parameter.

In the case of pollutants or pollutant parameters for which there are no approved methods under 40 C.F.R. part 136 or otherwise required under 40 C.F.R. chapter 1, subchapter N, monitoring must be conducted according to a test procedure specified in this Order for such pollutants or pollutant parameters. (40 C.F.R. §§ 122.21(e)(3), 122.41(j)(4), 122.44(i)(1)(iv).)

### **4. STANDARD PROVISIONS – RECORDS**

- 4.1. The Discharger shall retain records of all monitoring information, including all calibration and maintenance records and all original strip chart recordings for continuous monitoring instrumentation, copies of all reports required by this Order, and records of all data used to complete the application for this Order, for a period of at least three (3) years from the date of the sample, measurement, report, or application. This period may be extended by request of the Regional Water Board Executive Officer at any time. (40 C.F.R. § 122.41(j)(2).)
- 4.2. Records of monitoring information shall include:
  - 4.2.1. The date, exact place, and time of sampling or measurements (40 C.F.R. § 122.41(j)(3)(i));

- 4.2.2. The individual(s) who performed the sampling or measurements (40 C.F.R. § 122.41(j)(3)(ii));
  - 4.2.3. The date(s) analyses were performed (40 C.F.R. § 122.41(j)(3)(iii));
  - 4.2.4. The individual(s) who performed the analyses (40 C.F.R. § 122.41(j)(3)(iv));
  - 4.2.5. The analytical techniques or methods used (40 C.F.R. § 122.41(j)(3)(v)); and
  - 4.2.6. The results of such analyses. (40 C.F.R. § 122.41(j)(3)(vi).)
- 4.3.** Claims of confidentiality for the following information will be denied (40 C.F.R. § 122.7(b)):
- 4.3.1. The name and address of any permit applicant or Discharger (40 C.F.R. § 122.7(b)(1)); and
  - 4.3.2. Permit applications and attachments, permits, and effluent data. (40 C.F.R. § 122.7(b)(2).)

## **5. STANDARD PROVISIONS – REPORTING**

**5.1. Duty to Provide Information.** The Discharger shall furnish to the Regional Water Board, State Water Board, or U.S. EPA within a reasonable time, any information that the Regional Water Board, State Water Board, or U.S. EPA may request to determine whether cause exists for modifying, revoking and reissuing, or terminating this Order or to determine compliance with this Order. Upon request, the Discharger shall also furnish to the Regional Water Board, State Water Board, or U.S. EPA copies of records required to be kept by this Order. (40 C.F.R. § 122.41(h); Wat. Code, §§ 13267, 13383.)

### **5.2. Signatory and Certification Requirements**

- 5.2.1. All applications, reports, or information submitted to the Regional Water Board, State Water Board, and/or U.S. EPA shall be signed and certified in accordance with Standard Provisions – Reporting sections 5.2.2, 5.2.3, 5.2.4, 5.2.5, and 5.2.6 below. (40 C.F.R. § 122.41(k).)
- 5.2.2. For a corporation, all permit applications shall be signed by a responsible corporate officer. For the purpose of this section, a responsible corporate officer means: (1) a president, secretary, treasurer, or vice-president of the corporation in charge of a principal business function, or any other person who performs similar policy- or decision-making functions for the corporation, or (2) the manager of one or more manufacturing, production, or operating facilities, provided the manager is authorized to make management decisions that govern the operation of the regulated facility, including having the explicit or implicit duty of making major capital investment recommendations, and initiating and directing other comprehensive measures to ensure long term environmental



compliance with environmental laws and regulations; the manager can ensure that the necessary systems are established or actions taken to gather complete and accurate information for permit application requirements; and where authority to sign documents has been assigned or delegated to the manager in accordance with corporate procedures. (40 C.F.R. § 122.22(a)(1).)

For a partnership or sole proprietorship, all permit applications shall be signed by a general partner or the proprietor, respectively. (40 C.F.R. § 122.22(a)(2).)

For a municipal, state, federal, or other public agency, all permit applications shall be signed by either a principal executive officer or ranking elected official. For purposes of this provision, a principal executive officer of a federal agency includes (1) the chief executive officer of the agency, or (2) a senior executive officer having responsibility for the overall operations of a principal geographic unit of the agency (e.g., Regional Administrators of U.S. EPA). (40 C.F.R. § 122.22(a)(3).)

- 5.2.3. All reports required by this Order and other information requested by the Regional Water Board, State Water Board, or U.S. EPA shall be signed by a person described in Standard Provisions – Reporting section 5.2.2 above, or by a duly authorized representative of that person. A person is a duly authorized representative only if:
  - 5.2.3.1. The authorization is made in writing by a person described in Standard Provisions – Reporting section 5.2.2 above (40 C.F.R. § 122.22(b)(1));
  - 5.2.3.2. The authorization specifies either an individual or a position having responsibility for the overall operation of the regulated facility or activity, such as the position of plant manager, operator of a well or a well field, superintendent, position of equivalent responsibility, or an individual or position having overall responsibility for environmental matters for the company. (A duly authorized representative may thus be either a named individual or any individual occupying a named position.) (40 C.F.R. § 122.22(b)(2)); and
  - 5.2.3.3. The written authorization is submitted to the Regional Water Board and State Water Board. (40 C.F.R. § 122.22(b)(3).)
- 5.2.4. If an authorization under Standard Provisions – Reporting section 5.2.3 above is no longer accurate because a different individual or position has responsibility for the overall operation of the facility, a new authorization satisfying the requirements of Standard Provisions – Reporting section 5.2.3 above must be submitted to the Regional Water Board and State Water Board prior to or together with any reports, information, or applications to be signed by an authorized representative. (40 C.F.R. § 122.22(c).)
- 5.2.5. Any person signing a document under Standard Provisions – Reporting section 5.2.2 or 5.2.3 above shall make the following certification:

"I certify under penalty of law that this document and all attachments were prepared under my direction or supervision in accordance with a system designed to assure that qualified personnel properly gather and evaluate the information submitted. Based on my inquiry of the person or persons who manage the system or those persons directly responsible for gathering the information, the information submitted is, to the best of my knowledge and belief, true, accurate, and complete. I am aware that there are significant penalties for submitting false information, including the possibility of fine and imprisonment for knowing violations." (40 C.F.R. § 122.22(d).)

- 5.2.6. Any person providing the electronic signature for documents described in Standard Provisions – Reporting sections 5.2.1, 5.2.2, or 5.2.3 that are submitted electronically shall meet all relevant requirements of Standard Provisions – Reporting section 5.2, and shall ensure that all relevant requirements of 40 C.F.R. part 3 (Cross-Media Electronic Reporting) and 40 C.F.R. part 127 (NPDES Electronic Reporting Requirements) are met for that submission. (40 C.F.R. § 122.22(e).)

### **5.3. Monitoring Reports**

- 5.3.1. Monitoring results shall be reported at the intervals specified in the Monitoring and Reporting Program (Attachment E) in this Order. (40 C.F.R. § 122.41(l)(4).)
- 5.3.2. Monitoring results must be reported on a Discharge Monitoring Report (DMR) form or forms provided or specified by the Regional Water Board or State Water Board. All reports and forms must be submitted electronically to the initial recipient defined in Standard Provisions – Reporting section 5.10 and comply with 40 C.F.R. part 3, 40 C.F.R. section 122.22, and 40 C.F.R. part 127. (40 C.F.R. § 122.41(l)(4)(i).)
- 5.3.3. If the Discharger monitors any pollutant more frequently than required by this Order using test procedures approved under 40 C.F.R. part 136, or another method required for an industry-specific waste stream under 40 C.F.R. chapter 1, subchapter N, the results of such monitoring shall be included in the calculation and reporting of the data submitted in the DMR or reporting form specified by the Regional Water Board or State Water Board. (40 C.F.R. § 122.41(l)(4)(ii).)
- 5.3.4. Calculations for all limitations that require averaging of measurements shall utilize an arithmetic mean unless otherwise specified in this Order. (40 C.F.R. § 122.41(l)(4)(iii).)

- 5.4. Compliance Schedules.** Reports of compliance or noncompliance with, or any progress reports on, interim and final requirements contained in any compliance schedule of this Order shall be submitted no later than 14 days following each schedule date. (40 C.F.R. § 122.41(l)(5).)

## 5.5. Twenty-Four Hour Reporting

- 5.5.1. The Discharger shall report any noncompliance that may endanger health or the environment. Any information shall be provided orally within 24 hours from the time the Discharger becomes aware of the circumstances. A written report shall also be provided within five (5) days of the time the Discharger becomes aware of the circumstances. The report shall contain a description of the noncompliance and its cause; the period of noncompliance, including exact dates and times, and, if the noncompliance has not been corrected, the anticipated time it is expected to continue; and steps taken or planned to reduce, eliminate, and prevent reoccurrence of the noncompliance.

For noncompliance related to combined sewer overflows, sanitary sewer overflows, or bypass events, these reports must include the data described above (with the exception of time of discovery) as well as the type of event (i.e., combined sewer overflow, sanitary sewer overflow, or bypass event), type of overflow structure (e.g., manhole, combined sewer overflow outfall), discharge volume untreated by the treatment works treating domestic sewage, types of human health and environmental impacts of the event, and whether the noncompliance was related to wet weather.

As of December 21, 2025, all reports related to combined sewer overflows, sanitary sewer overflows, or bypass events must be submitted to the Regional Water Board and must be submitted electronically to the initial recipient defined in Standard Provisions – Reporting section 5.10. The reports shall comply with 40 C.F.R. part 3, 40 C.F.R. section 122.22, and 40 C.F.R. part 127. The Regional Water Board may also require the Discharger to electronically submit reports not related to combined sewer overflows, sanitary sewer overflows, or bypass events under this section. (40 C.F.R. § 122.41(l)(6)(i).)

- 5.5.2. The following shall be included as information that must be reported within 24 hours:
- 5.5.2.1. Any unanticipated bypass that exceeds any effluent limitation in this Order. (40 C.F.R. § 122.41(l)(6)(ii)(A).)
- 5.5.2.2. Any upset that exceeds any effluent limitation in this Order. (40 C.F.R. § 122.41(l)(6)(ii)(B).)
- 5.5.3. The Regional Water Board may waive the above required written report on a case-by-case basis if an oral report has been received within 24 hours. (40 C.F.R. § 122.41(l)(6)(ii)(B).)

- 5.6. Planned Changes.** The Discharger shall give notice to the Regional Water Board as soon as possible of any planned physical alterations or additions to the permitted facility. Notice is required under this provision only when (40 C.F.R. § 122.41(l)(1)):

- 5.6.1. The alteration or addition to a permitted facility may meet one of the criteria for determining whether a facility is a new source in 40 C.F.R. section 122.29(b) (40 C.F.R. § 122.41(l)(1)(i)); or
- 5.6.2. The alteration or addition could significantly change the nature or increase the quantity of pollutants discharged. This notification applies to pollutants that are not subject to effluent limitations in this Order unless the discharge is an existing manufacturing, commercial, mining, or silvicultural discharge as referenced in 40 C.F.R. section 122.42(a). (40 C.F.R. § 122.41(l)(1)(ii).) If the discharge is an existing manufacturing, commercial, mining, or silvicultural discharge as referenced in 40 C.F.R. section 122.42(a), this notification applies to pollutants that are subject neither to effluent limitations in this Order nor to notification requirements under 40 C.F.R. section 122.42(a)(1) (see Additional Provisions – Notification Levels section 7.1.1). (40 C.F.R. § 122.41(l)(1)(ii).)
- 5.7. Anticipated Noncompliance.** The Discharger shall give advance notice to the Regional Water Board of any planned changes in the permitted facility or activity that may result in noncompliance with this Order’s requirements. (40 C.F.R. § 122.41(l)(2).)
- 5.8. Other Noncompliance.** The Discharger shall report all instances of noncompliance not reported under Standard Provisions – Reporting sections 5.3, 5.4, and 5.5 above at the time monitoring reports are submitted. The reports shall contain the information listed in Standard Provision – Reporting section 5.5 above. For noncompliance related to combined sewer overflows, sanitary sewer overflows, or bypass events, these reports shall contain the information described in Standard Provision – Reporting section 5.5 and the applicable required data in appendix A to 40 C.F.R. part 127. The Regional Water Board may also require the Discharger to electronically submit reports not related to combined sewer overflows, sanitary sewer overflows, or bypass events under this section. (40 C.F.R. § 122.41(l)(7).)
- 5.9. Other Information.** When the Discharger becomes aware that it failed to submit any relevant facts in a permit application, or submitted incorrect information in a permit application or in any report to the Regional Water Board, State Water Board, or U.S. EPA, the Discharger shall promptly submit such facts or information. (40 C.F.R. § 122.41(l)(8).)
- 5.10. Initial Recipient for Electronic Reporting Data.** The owner, operator, or duly authorized representative is required to electronically submit NPDES information specified in appendix A to 40 C.F.R. part 127 to the initial recipient defined in 40 C.F.R. section 127.2(b). U.S. EPA will identify and publish the list of initial recipients on its website and in the Federal Register, by state and by NPDES data group [see 40 C.F.R. section 127.2(c)]. U.S. EPA will update and maintain this list. (40 C.F.R. § 122.41(l)(9).)

## 6. STANDARD PROVISIONS – ENFORCEMENT

6.1. The Regional Water Board is authorized to enforce the terms of this permit under several provisions of the Water Code, including, but not limited to, Water Code sections 13268, 13385, 13386, and 13387.

## 7. ADDITIONAL PROVISIONS – NOTIFICATION LEVELS

7.1. **Non-Municipal Facilities.** Existing manufacturing, commercial, mining, and silvicultural Dischargers shall notify the Regional Water Board as soon as they know or have reason to believe (40 C.F.R. § 122.42(a)):

7.1.1. That any activity has occurred or will occur that would result in the discharge, on a routine or frequent basis, of any toxic pollutant that is not limited in this Order, if that discharge will exceed the highest of the following “notification levels” (40 C.F.R. § 122.42(a)(1)):

7.1.1.1. 100 micrograms per liter ( $\mu\text{g/L}$ ) (40 C.F.R. § 122.42(a)(1)(i));

7.1.1.2. 200  $\mu\text{g/L}$  for acrolein and acrylonitrile; 500  $\mu\text{g/L}$  for 2,4 dinitrophenol and 2-methyl 4,6 dinitrophenol; and 1 milligram per liter ( $\text{mg/L}$ ) for antimony (40 C.F.R. § 122.42(a)(1)(ii));

7.1.1.3. Five (5) times the maximum concentration reported for that pollutant in the Report of Waste Discharge (40 C.F.R. § 122.42(a)(1)(iii)); or

7.1.1.4. The level established by the Regional Water Board in accordance with 40 C.F.R. section 122.44(f). (40 C.F.R. § 122.42(a)(1)(iv).)

7.1.2. That any activity has occurred or will occur that would result in the discharge, on a non-routine or infrequent basis, of any toxic pollutant that is not limited in this Order, if that discharge will exceed the highest of the following “notification levels” (40 C.F.R. § 122.42(a)(2)):

7.1.2.1. 500 micrograms per liter ( $\mu\text{g/L}$ ) (40 C.F.R. § 122.42(a)(2)(i));

7.1.2.2. 1 milligram per liter ( $\text{mg/L}$ ) for antimony (40 C.F.R. § 122.42(a)(2)(ii));

7.1.2.3. Ten (10) times the maximum concentration reported for that pollutant in the Report of Waste Discharge (40 C.F.R. § 122.42(a)(2)(iii)); or

7.1.2.4. The level established by the Regional Water Board in accordance with 40 C.F.R. section 122.44(f). (40 C.F.R. § 122.42(a)(2)(iv).)

## 7.2 Publicly Owned Treatment Works (POTWs)

7.2.1. All POTWs shall provide adequate notice to the Regional Water Board of any new introduction of pollutants into the POTW from an indirect discharger that

would be subject to CWA sections 301 or 306 if it were directly discharging those pollutants (40 C.F.R. § 122.42(b)(1)).

- 7.2.2. All POTWs shall provide adequate notice to the Regional Water Board of any substantial change in the volume or character of pollutants being introduced into that POTW by a source introducing pollutants into the POTW at the time of adoption of this Order. (40 C.F.R. § 122.42(b)(2).)
- 7.2.3. Adequate notice shall include information on the quality and quantity of effluent introduced into the POTW as well as any anticipated impact of the change on the quantity or quality of effluent to be discharged from the POTW. (40 C.F.R. § 122.42(b)(3).)

## ATTACHMENT E – MONITORING AND REPORTING PROGRAM

### CONTENTS

1. GENERAL MONITORING PROVISIONS.....	E-2
2. MONITORING LOCATIONS .....	E-3
3. EFFLUENT MONITORING .....	E-3
4. TOXICITY MONITORING.....	E-4
5. RECEIVING WATER MONITORING.....	E-4
6. REPORTING REQUIREMENTS .....	E-5

### TABLES

TABLE E-1. MONITORING LOCATIONS.....	E-3
TABLE E-2. EFFLUENT MONITORING .....	E-3
TABLE E-3. RECEIVING WATER MONITORING.....	E-5
TABLE E-4. CIWQS REPORTING .....	E-5
TABLE E-5. MONITORING PERIODS.....	E-6

## ATTACHMENT E – MONITORING AND REPORTING PROGRAM

Clean Water Act (CWA) section 308 and 40 C.F.R. sections 122.41(h), (j)-(l), 122.44(i), and 122.48 require that all NPDES permits specify monitoring and reporting requirements. Water Code section 13383 also authorizes the Regional Water Board to establish monitoring, inspection, entry, reporting, and recordkeeping requirements. This MRP establishes monitoring, reporting, and recordkeeping requirements that implement the federal and State laws and regulations.

### 1. GENERAL MONITORING PROVISIONS

- 1.1. The Discharger shall comply with this MRP. The Executive Officer may amend this MRP pursuant to 40 C.F.R. section 122.63. If any discrepancies exist between this MRP and the “Regional Standard Provisions, and Monitoring and Reporting Requirements (Supplement to Attachment D) for NPDES Wastewater Discharge Permits” (Attachment G), this MRP shall prevail.
- 1.2. The Discharger shall conduct all monitoring in accordance with Attachment D section 3, as supplemented by Attachment G. Equivalent test methods must be more sensitive than those specified in 40 C.F.R. section 136 and must be specified in this permit.
- 1.3. For the analysis of monitoring samples, the Discharger shall use laboratories certified by the State Water Resources Control Board (State Water Board) in accordance with Water Code section 13176 and shall obtain quality assurance/quality control data with laboratory reports. For any onsite field tests (e.g., turbidity, pH, temperature, dissolved oxygen, conductivity, disinfectant residual) analyzed by a noncertified laboratory, the Discharger shall implement a Quality Assurance-Quality Control Program. The Discharger shall keep a manual onsite containing the steps followed in this program and shall demonstrate sufficient capability to adequately perform these field tests (e.g., qualified and trained employees, properly calibrated and maintained field instruments). The program shall conform to U.S. EPA guidelines or other approved procedures.
- 1.4. The Discharger shall ensure that the results of the Discharge Monitoring Report-Quality Assurance (DMR-QA) Study or most recent Water Pollution Performance Evaluation Study are submitted annually to the State Water Board at the following address:

State Water Resources Control Board;  
Quality Assurance Program Officer;  
Office of Information Management and Analysis;  
1001 I Street  
Sacramento, CA 95814



## 2. MONITORING LOCATIONS

The Discharger shall establish the following monitoring locations to demonstrate compliance with the effluent limitations, discharge specifications, and other requirements of this Order:

**Table E-1. Monitoring Locations**

Monitoring Location Type	Monitoring Location	Monitoring Location Description
Effluent	EFF-003	A point following all treatment that represents all flow tributary to Discharge Point 003.
Receiving Water	RSW-003U	A point in the receiving water located upstream of Discharge Point 003 where impacts of the discharge would not be expected.

## 3. EFFLUENT MONITORING

3.1. When discharging at Discharge Point 003, the Discharger shall monitor discharges at Monitoring Location EFF-003 as follows:

**Table E-2. Effluent Monitoring**

Parameter	Unit	Sample Type	Minimum Sampling Frequency
Flow rate and volume <sup>[1]</sup>	MGD/MG	Continuous	Continuous/D
Total Suspended Solids (TSS)	mg/L	Grab	1/Month
Total Settleable Matter	mg/L	Grab	1/Month
Chlorine, Total Residual <sup>[2]</sup>	mg/L	Continuous or Grab	1/Hour
pH	standard units	Grab	2/Week
Acute Toxicity <sup>[3]</sup>	% survival	Grab	1/Quarter
Dichlorobromomethane	µg/L	Grab	1/Month
Priority Pollutants <sup>[4]</sup>	µg/L	Grab	Once

Footnotes:

<sup>[1]</sup> Flow shall be monitored by flow meter or, if no flow meter is in place, estimated. The Executive Officer may require the Discharger to install a flow meter. The following shall be reported in self-monitoring reports:

- Daily average flow rate (MGD)
- Total monthly flow volume (MG)

<sup>[2]</sup> Effluent residual chlorine concentrations shall be monitored continuously or, at a minimum, every hour. The Discharger shall describe all excursions of the chlorine limit in the transmittal letter of self-monitoring reports as required by Attachment G section 5.3.1.1. If monitoring continuously, the Discharger shall report through data upload to CIWQS, from discrete readings of the continuous monitoring every hour on the hour, the maximum for each day and any other discrete hourly reading that exceed the effluent limit, and, for the purpose of mandatory minimum penalties required by Water Code section 13385(i), compliance shall be based only on these discrete readings. The Discharger shall retain continuous monitoring readings for at least three years. The Regional Water Board reserves the right to use all continuous monitoring data for discretionary enforcement.

The Discharger may elect to use a continuous on-line monitoring system for measuring or determining that residual dechlorinating agent is present. This monitoring system may be used to prove that anomalous residual chlorine exceedances measured by on-line chlorine analyzers are false positives and are not valid total residual chlorine detections because it is chemically improbable to have chlorine present in the presence of sodium bisulfite. If Regional Water Board staff finds convincing evidence that chlorine residual exceedances are false positives, the exceedances are not violations of this Order's total residual chlorine limit.

<sup>[3]</sup> Acute toxicity tests shall be performed in accordance with MRP section 4

<sup>[4]</sup> The Discharger shall monitor for the pollutants listed in Attachment G, Table B.

#### 4. TOXICITY MONITORING

- 4.1. Compliance with the acute toxicity effluent limitations shall be evaluated at Monitoring Location EFF-003 by measuring survival of test organisms exposed to 96-hour static renewal bioassays. Samples shall be collected on days coincident with effluent sampling.
- 4.2. Test organisms shall be rainbow trout (*Oncorhynchus mykiss*). Alternatively, the Executive Officer may specify a more sensitive organism or, if testing a particular organism proves unworkable, the most sensitive organism available.
- 4.3. All bioassays shall be performed according to the most up-to-date protocols in 40 C.F.R. part 136, currently *Methods for Measuring the Acute Toxicity of Effluents and Receiving Water to Freshwater and Marine Organisms*, 5th Edition (EPA-821-R-02-012). If these protocols prove unworkable, the Executive Officer and the Environmental Laboratory Accreditation Program may grant exceptions in writing upon the Discharger's request with justification.
- 4.4. If the Discharger demonstrates that specific identifiable substances in the discharge are rapidly rendered harmless upon discharge to the receiving water, compliance with the acute toxicity limit may be determined after test samples are adjusted to remove the influence of those substances. Written acknowledgement that the Executive Officer concurs with the Discharger's demonstration and that the adjustment will not remove the influence of other substances must be obtained prior to any such adjustment. The Discharger may manually adjust the pH of whole effluent acute toxicity samples prior to performing bioassays. Effluent shall be dechlorinated prior to testing if it contains chlorine.
- 4.5. Bioassay water monitoring shall include pH, dissolved oxygen, and temperature on a daily basis; and hardness and alkalinity on the first day. These results shall be reported.
- 4.6. If final or intermediate results of an acute bioassay test indicate a violation or threatened violation (e.g., the percentage of surviving test organisms is less than 70 percent), the Discharger shall initiate a new test as soon as practical. The Discharger shall repeat the test until a test fish survival rate of 90 percent or greater is observed.
- 4.7. The Discharger shall investigate the cause of any mortalities and report its findings in the next self-monitoring report.

#### 5. RECEIVING WATER MONITORING

The Discharger shall monitor receiving waters at Monitoring Location RSW-003U as follows:

**Table E-3. Receiving Water Monitoring**

Parameter	Unit	Sample Type <sup>[1]</sup>	Minimum Sampling Frequency
Dichlorobromomethane	µg/L	Grab	2/Year
Priority Pollutants <sup>[2]</sup>	µg/L	Grab	Once

**Footnotes:**

<sup>[1]</sup> Samples shall be collected approximately one foot below the surface of the receiving water body. The Discharger shall note in the annual report if it was unable to collect samples and explain why samples could not be collected (e.g., the receiving water was dry).

<sup>[2]</sup> The Discharger shall monitor for the pollutants listed in Attachment G, Table B.

**6. REPORTING REQUIREMENTS**

**6.1. General Monitoring and Reporting Requirements.** The Discharger shall comply with all Standard Provisions (Attachments D and G) related to monitoring, reporting, and recordkeeping.

**6.2. Self-Monitoring Reports (SMRs)**

6.2.1. **SMR Format.** The Discharger shall electronically submit SMRs using the State Water Board’s [California Integrated Water Quality System \(CIWQS\) Program website](http://waterboards.ca.gov/water_issues/programs/ciwqs) (waterboards.ca.gov/water\_issues/programs/ciwqs). The CIWQS website will provide additional information for SMR submittal in the event of a planned service interruption for electronic submittal.

6.2.2. **SMR Due Dates and Contents.** The Discharger shall submit annual SMRs by February 1 each year, covering the previous calendar year. The annual SMR shall contain the applicable items described in Provision 6.3.2 (Best Management Practices Plan) of the Order and Attachment G section 5.3.1.6.

6.2.3. **Specifications for Submitting SMRs to CIWQS.** The Discharger shall submit analytical results and other information using one of the following methods:

**Table E-4. CIWQS Reporting**

Parameter	Method of Reporting: EDF/CDF data upload	Parameter
All parameters identified in influent, effluent, and receiving water monitoring tables (except Dissolved Oxygen and Temperature)	Required for all results	-
Dissolved Oxygen, Temperature	Required for monthly maximum and minimum results only <sup>[1]</sup>	Discharger may use this method for all results or keep records
Antimony, Arsenic, Beryllium, Cadmium, Chromium, Copper, Cyanide, Lead, Mercury, Nickel, Selenium, Silver, Thallium, Zinc, Dioxins & Furans (by U.S. EPA Method 1613), Other Pollutants (by U.S. EPA Methods 601, 602, 608, 610, 614, 624, and 625)	Required for all results <sup>[2]</sup>	-

Parameter	Method of Reporting: EDF/CDF data upload	Parameter
Volume and Duration of Blended Discharge <sup>[3]</sup>	Required for all blended effluent discharges	-
Analytical Method	Not required (Discharger may select "data unavailable") <sup>[1]</sup>	-
Collection Time, Analysis Time	Not required	-

**Footnotes:**

- <sup>[1]</sup> The Discharger shall continue to monitor at the minimum frequency specified in this MRP, keep records of the measurements, and make the records available upon request.
- <sup>[2]</sup> These parameters require EDF/CDF data upload or manual entry regardless of whether monitoring is required by this MRP or other provisions of this Order (except for biosolids, sludge, or ash provisions).
- <sup>[3]</sup> The requirement for volume and duration of blended discharge applies only if this Order authorizes the Discharger to discharge blended effluent.

The Discharger shall arrange all reported data in a tabular format and summarize data to clearly illustrate whether the Facility is operating in compliance with effluent limitations. The Discharger is not required to duplicate the submittal of data entered in a tabular format within CIWQS. When electronic submittal of data is required and CIWQS does not provide for entry into a tabular format, the Discharger shall electronically submit the data in a tabular format as an attachment.

**6.2.4. Monitoring Periods.** Monitoring periods for all required monitoring shall be as set forth below unless otherwise specified:

**Table E-5. Monitoring Periods**

Sampling Frequency	Monitoring Period Begins On...	Monitoring Period
Continuous/D	Order effective date	All times
1/Hour	Order effective date	Every hour on the hour
1/Day	Order effective date	Any 24-hour period that reasonably represents a calendar day for sampling purposes (e.g., beginning at midnight and continuing through 11:59 p.m.)
1/Week 2/Week 3/Week 4/Week 5/Week	First Sunday following or on Order effective date	Sunday through Saturday
1/Month	First day of calendar month following or on Order effective date	First day of calendar month through last day of calendar month
1/Quarter	Closest January 1, April 1, July 1, or October 1 before or after Order effective date <sup>[1]</sup>	January 1 through March 31 July 1 through September 30 April 1 through June 30 October 1 through December 31
1/Year	Closest January 1 before or after Order effective date <sup>[1]</sup>	January 1 through December 31
2/Year	Closest November 1 or February 1 before or after Order effective date <sup>[1]</sup>	Once after the first storm of the season during the interval from November 1 through January 31, and

Sampling Frequency	Monitoring Period Begins On...	Monitoring Period
		once during the interval from February 1 through May 31
Once	Order effective date	Once during the term of the Order within 12 months prior to applying for permit reissuance

Footnote:

<sup>(1)</sup> Monitoring performed during the previous order term may be used to satisfy monitoring required by this Order.

6.2.5. **RL and MDL Reporting.** The Discharger shall report with each sample result the Reporting Level (RL) and Method Detection Limit (MDL) as determined by the procedure in 40 C.F.R. part 136. The Discharger shall report the results of analytical determinations for the presence of chemical constituents in a sample using the following reporting protocols:

6.2.5.1. Sample results greater than or equal to the RL shall be reported as measured by the laboratory (i.e., the measured chemical concentration in the sample).

6.2.5.2. Sample results less than the RL, but greater than or equal to the laboratory's MDL, shall be reported as "Detected, but Not Quantified," or DNQ. The estimated chemical concentration of the sample shall also be reported.

For purposes of data collection, the Discharger shall require the laboratory to write the estimated chemical concentration next to DNQ. The laboratory may, if such information is available, include numerical estimates of the data quality for the reported result. Numerical estimates of data quality may be percent accuracy ( $\pm$  a percentage of the reported value), numerical ranges (low to high), or any other means the laboratory considers appropriate.

6.2.5.3. Sample results less than the laboratory's MDL shall be reported as "Not Detected", or ND.

6.2.5.4. The Discharger shall instruct laboratories to establish calibration standards so that the minimum level (ML) value (or its equivalent if there is differential treatment of samples relative to calibration standards) is the lowest calibration standard. At no time is the Discharger to use analytical data derived from extrapolation beyond the lowest point of the calibration curve.

6.2.6. **Compliance Determination.** Compliance with effluent limitations shall be determined using sample reporting protocols defined above, in the Fact Sheet, and in Attachments A, D, and G. For purposes of reporting and administrative enforcement by the Regional Water Board and State Water Board, the Discharger shall be deemed out of compliance with effluent limitations if the concentration of the pollutant in the monitoring sample is greater than the effluent limitation and, if applicable, greater than or equal to the RL.

**6.3. Discharge Monitoring Reports (DMRs).** DMRs are U.S. EPA reporting requirements. The Discharger shall electronically certify and submit DMRs together with SMRs using Electronic Self-Monitoring Reports module eSMR 2.5 or the latest upgraded version. Electronic DMR submittal shall be in addition to electronic SMR submittal. Information about electronic DMR submittal is available at the [DMR website](https://waterboards.ca.gov/water_issues/programs/discharge_monitoring) (waterboards.ca.gov/water\_issues/programs/discharge\_monitoring).

## ATTACHMENT F – FACT SHEET

### CONTENTS

<b>1. PERMIT INFORMATION</b> .....	<b>F-3</b>
<b>2. FACILITY DESCRIPTION</b> .....	<b>F-4</b>
<b>3. APPLICABLE PLANS, POLICIES, AND REGULATIONS</b> .....	<b>F-7</b>
<b>4. RATIONALE FOR EFFLUENT LIMITATIONS AND DISCHARGE SPECIFICATIONS</b> .....	<b>F-10</b>
4.1. DISCHARGE PROHIBITIONS .....	F-10
4.2. TECHNOLOGY-BASED EFFLUENT LIMITATIONS.....	F-12
4.2.1. <i>Scope and Authority</i> .....	F-12
4.2.2. <i>Effluent Limitations</i> .....	F-13
4.3. WATER QUALITY-BASED EFFLUENT LIMITATIONS .....	F-13
4.3.1. <i>Scope and Authority</i> .....	F-13
4.3.2. <i>Beneficial Uses and Water Quality Criteria and Objectives</i> .....	F-14
4.3.3. <i>Reasonable Potential Analysis</i> .....	F-15
4.3.4. <i>Water Quality-Based Effluent Limitations</i> .....	F-20
4.4. DISCHARGE REQUIREMENT CONSIDERATIONS.....	F-26
<b>5. RATIONALE FOR RECEIVING WATER LIMITATIONS</b> .....	<b>F-27</b>
<b>6. RATIONALE FOR PROVISIONS</b> .....	<b>F-28</b>
6.1. STANDARD PROVISIONS.....	F-28
6.2. MONITORING AND REPORTING PROVISIONS.....	F-28
6.3. SPECIAL PROVISIONS.....	F-28
6.3.1. <i>Reopener Provisions</i> .....	F-28
6.3.2. <i>Best Management Practices (BMPs) Plan</i> .....	F-28
<b>7. RATIONALE FOR MONITORING AND REPORTING REQUIREMENTS</b> .....	<b>F-29</b>
<b>8. PUBLIC PARTICIPATION</b> .....	<b>F-29</b>

## TABLES

TABLE F-1. FACILITY INFORMATION .....	F-3
TABLE F-2. PREVIOUS EFFLUENT LIMITATIONS AND MONITORING DATA .....	F-6
TABLE F-3. PREVIOUS EFFLUENT LIMITATIONS AND MONITORING DATA .....	F-6
TABLE F-4. BENEFICIAL USES.....	F-8
TABLE F-5. REASONABLE POTENTIAL ANALYSIS FOR PRIORITY POLLUTANTS.....	F-16
TABLE F-6. WQBEL CALCULATIONS.....	F-25



## ATTACHMENT F – FACT SHEET

This Fact Sheet includes the legal requirements and technical rationale that serve as the basis for the requirements of this Order. As described in section 2.2 of the Order, the Regional Water Board incorporates this Fact Sheet as findings supporting the issuance of the Order.

### 1. PERMIT INFORMATION

The following table summarizes administrative information related to the Facility.

**Table F-1. Facility Information**

WDID	2 071113001
CIWQS Place ID	246192
Discharger	East Bay Municipal Utility District
Facility Name	Orinda Water Treatment Plant
Facility Address	190 Camino Pablo Orinda, CA 94563 Contra Costa County
Facility Contact, Title, and Phone	Chris Burquez, Supervisor, (510) 287-1963
Authorized Person to Sign and Submit Reports	Chris Burquez
Mailing Address	375 Eleventh Street (MS #704), Oakland, CA 94607
Billing Address	Same as Mailing Address
Facility Type	Water Treatment Plant
Major or Minor Facility	Minor
Water Quality Threat	3
Complexity	C
Pretreatment Program	No
Recycling Requirements	None
Facility Permitted Flow	30 MGD (maximum), 2.3 MGD (average)
Watershed	San Pablo Creek
Receiving Water	San Pablo Creek
Receiving Water Type	Freshwater

**1.1.** The East Bay Municipal Utility District (Discharger) owns and operates the Orinda Water Treatment Plant (Facility), a potable water treatment plant in Orinda. The Facility discharges wastewater to San Pablo Creek, a water of the United States.

For the purposes of this Order, references to the “discharger” or “permittee” in applicable federal and State laws, regulations, plans, and policies are held to be equivalent to references to the Discharger herein.

**1.2.** The Discharger is regulated pursuant to National Pollutant Discharge Elimination System (NPDES) Permit CA0038342. The Discharger was previously subject to

Order R2-2015-0041 (previous order), which became effective on January 1, 2016, and was administratively extended by operation of law past its stated expiration date (December 31, 2020). The Discharger filed a Report of Waste Discharge and submitted an application for reissuance of its Waste Discharge Requirements (WDRs) and NPDES permit on April 1, 2020.

- 1.3. The Discharger is authorized to discharge subject to the WDRs in this Order at the discharge location described in Table 1 of this Order. Regulations in 40 C.F.R. section 122.46 limit the duration of NPDES permits to a fixed term not to exceed five years. Accordingly, this Order limits the effective period for the discharge authorization. Pursuant to 40 C.F.R. section 122.6(d) and California Code of Regulations, title 23, section 2235.4, the terms and conditions of an expired permit are automatically continued pending reissuance of the permit if the Discharger complies with all requirements for continuation of expired permits.

## 2. FACILITY DESCRIPTION

### 2.1. Operations and Wastewater Controls

- 2.1.1. **Location and Service Area.** The Facility is one of six potable water treatment facilities the Discharger operates in the East Bay to treat water prior to distribution to 1.34 million customers in Alameda and Contra Costa counties. The Facility has the largest output of the six facilities, with a maximum design capacity of 200 million gallons per day (MGD). The Facility provides potable water to all or parts of Alameda, Albany, Berkeley, El Cerrito, Emeryville, Moraga, Oakland, Orinda, Piedmont, Richmond, and San Leandro. The other treatment facilities (Upper San Leandro in Oakland, San Pablo in Kensington, Sobrante in El Sobrante, Lafayette, and Walnut Creek) supply water in varying amounts to the balance of the Discharger's service area.
- 2.1.2. **Influent Water.** The Facility receives water from the Pardee Reservoir, located in the foothills of the Sierra Nevada. The water flows by gravity from the Pardee Reservoir to the East Bay via three 90-mile-long Mokelumne Aqueducts. As the water enters the Mokelumne Aqueducts at Pardee, it is treated with liquid lime for corrosion protection and sodium hypochlorite for disinfection. Additional sodium hypochlorite is added to the Mokelumne Aqueducts at the Walnut Creek water treatment plant, as needed. The Discharger does not use copper sulfate to treat water in the Mokelumne Aqueducts. Depending on seasonal and other influences, however, water from the Pardee Reservoir may contain detectable levels of naturally occurring copper.

In Walnut Creek, Mokelumne Aqueducts No. 1 and No. 2 combine to become Lafayette Aqueduct No. 1, and Mokelumne Aqueduct No. 3 becomes Lafayette Aqueduct No. 2. The aqueducts are typically operated so that no chlorine residual remains in the water reaching the Facility through Lafayette Aqueduct No. 1. To comply with drinking water requirements, a chlorine residual between approximately 0.09 and 0.15 mg/L is maintained in the water reaching the

Facility through Lafayette Aqueduct No. 2. The water is dechlorinated with sodium bisulfite as it approaches the Facility.

The Facility also receives water as needed from the Briones Reservoir, located approximately one mile northeast of the Facility, via Lafayette Aqueduct No. 2.

- 2.1.3 **Water Treatment.** At the Facility, water passes through dual media filters to remove soil and other small particles, and polyaluminum chloride and a polymer are added to facilitate solids removal. Every 8 to 96 hours, each filter is backwashed to remove accumulated solids. The backwashing frequency depends on influent water quality, which varies seasonally. The volume of backwash water generated during each cycle varies between 100,000 and 300,000 gallons.

Backwash water is pumped to one of two adjacent 0.75-acre, 1.5-million-gallon, concrete-lined settling basins to remove suspended solids prior to discharge. The filters collect water leakage, which is also piped to the settling basins. The maximum pumping capacity to the settling basins is 30 MGD.

The two settling basins alternate between active and passive modes. The active basin receives backwash water from the filters, and solids settle as water flows through the active basin. Clarified filter backwash water from the active basin is dechlorinated before discharge to San Pablo Creek. The settling basins are designed to store the settled solids generated in approximately one month. Depending on seasonal demands, a basin may be active or passive for four to six weeks.

When the active basin is taken out of service, washwater flows are diverted to the other basin, and the active basin becomes the passive basin. The remaining water from the now passive basin is decanted to the inlet sump and pumped to the now active basin at a slow rate (i.e., over a few days to a week). Accumulated solids from the bottom of the passive basin have an estimated solids content of 0.5 to 3 percent and are pumped from the basin to a tank truck loading station for offsite disposal. Any spillage that may occur at the truck loading station is piped to the active basin.

- 2.1.4. **Planned Changes.** The Discharger plans no changes to its operations.

- 2.2. **Discharge Points and Receiving Waters.** Clarified filter backwash water decanted from the active settling basin is dechlorinated and discharged to San Pablo Creek at Discharge Point 003. Water is discharged daily, however, the volume varies based on the frequency of filter backwashing. The average flow at Discharge Point 003 is 2.3 MGD.

- 2.3. **Previous Requirements and Monitoring Data.** The table below presents the previous order's effluent limitations and representative monitoring data from the previous order term (January 2016 – December 2020) and January 2021 dichlorobromomethane monitoring data:

**Table F-2. Previous Effluent Limitations and Monitoring Data**

Parameter	Units	Average Monthly Limit	Average Weekly Limit	Maximum Daily Limit	Other Limit	Long-Term Average	Highest Daily Value
pH	s.u.	-	-	-	6.5 – 8.5 <sup>[1]</sup>	-	6.5 – 8.2 <sup>[2]</sup>
Total Suspended Solids (TSS)	mg/L	30	45	-	-	3.2	13
Settleable Matter	mL/L-hr	0.1		0.2		0.1	0.1
Chlorine, Total Residual	mg/L	-	-	-	0.0 <sup>[3]</sup>	-	0.22
Dichlorobromo methane	µg/L	3.2	-	4.4	-	1.5	3.4 <sup>[4]</sup>
Acute Toxicity	% survival	-	-	-	Not less than 70% (Single-Sample Maximum), Not less than 90% (Three-Sample Median)	95	15 <sup>[5]</sup>

Footnotes:

- <sup>[1]</sup> Instantaneous minimum and instantaneous maximum.
- <sup>[2]</sup> Range of lowest and highest pH values.
- <sup>[3]</sup> Instantaneous maximum.
- <sup>[4]</sup> Detected on January 25, 2021.
- <sup>[5]</sup> Lowest percent survival.

**2.4. Compliance Summary**

2.4.1. **Treatment Plant.** The Discharger violated its numeric effluent limitations three times during the previous order term.

**Table F-3. Previous Effluent Limitations and Monitoring Data**

Date of Violation	Parameter	Units	Effluent Limitation	Reported Value
8/8/2016	Acute Toxicity (single sample)	% survival	70	15
9/5/2017	Chlorine, Total Residual (instantaneous maximum)	mg/L	0.0	0.22
1/25/2021	Dichlorobromomethane (average monthly)	µg/L	3.2	3.4

On August 8, 2016, the Discharger violated the acute toxicity effluent limits. The Discharger conducted accelerated monitoring; however, subsequent bioassay tests resulted in 100% survival. The Discharger was unable to determine the source of the toxicity.

On September 5, 2017, the Discharger discharged approximately 230,000 gallons of effluent that exceeded the effluent limit for total chlorine residual to San Pablo Creek. The Discharger attributed the exceedance to a chlorine

dosage increase when returning Lafayette Aqueduct No. 1 to service and high backwash wastewater flows delivered to the settling ponds. The Discharger corrected the exceedance by increasing the dosage of sodium bisulfite to dechlorinate the backwash water. Upon further investigation, the Discharger found that it did not have appropriate equipment and had not established appropriate protocols to monitor total chlorine residual as required by the previous order. On May 24, 2019, the Regional Water Board issued Administrative Civil Liability Order R2-2019-1015 that included a \$120,100 penalty for the total chlorine residual effluent limit violation and total chlorine residual monitoring deficiencies that occurred from January 2016 through December 2017.

On January 25, 2021, the Discharger exceeded the dichlorobromomethane effluent limit. The Discharger attributed the exceedance to a temporary shift of water supply from Pardee Reservoir (the primary source) to Briones Reservoir while the Discharger performed capital improvements. The Briones Reservoir has higher concentrations of naturally-occurring bromide, which can form dichlorobromomethane when the water is chlorinated. The Discharger collected three samples in February 2021 that confirmed compliance with effluent limits.

- 2.5. Sea Level Rise.** Sea level rise does not threaten the Facility, which is located approximately 10 miles upstream of San Pablo Bay and discharges to San Pablo Creek.

### **3. APPLICABLE PLANS, POLICIES, AND REGULATIONS**

The requirements contained in this Order are based on the requirements and authorities described in this section.

- 3.1. Legal Authorities.** This Order serves as WDRs pursuant to California Water Code article 4, chapter 4, division 7 (commencing with § 13260). This Order is also issued pursuant to federal Clean Water Act (CWA) section 402 and implementing regulations adopted by the U.S. EPA, and Water Code chapter 5.5, division 7 (commencing with § 13370). It serves as an NPDES permit authorizing the Discharger to discharge into waters of the United States at the discharge location described in Table 1 subject to the WDRs in this Order.

- 3.2. California Environmental Quality Act (CEQA).** Under Water Code section 13389, this action to adopt an NPDES permit is exempt from the provisions of the California Environmental Quality Act (CEQA), Public Resources Code division 13, chapter 3 (commencing with § 21100).

### **3.3. State and Federal Laws, Regulations, Policies, and Plans**

- 3.3.1. Water Quality Control Plan.** The Regional Water Board adopted the *Water Quality Control Plan for the San Francisco Bay Basin* (Basin Plan), which designates beneficial uses, establishes water quality objectives, and contains implementation programs and policies to achieve those objectives for all waters

addressed through the plan. Requirements in this Order implement the Basin Plan. In addition, this Order implements State Water Board Resolution 88-63, which established State policy that all waters, with certain exceptions, should be considered suitable or potentially suitable for municipal or domestic supply. Beneficial uses applicable to San Pablo Creek are as follows:

**Table F-4. Beneficial Uses**

Discharge Points	Receiving Water	Beneficial Uses
003	San Pablo Creek	Municipal and Domestic Supply (MUN) Freshwater Replenishment (FRESH) Cold Freshwater Habitat (COLD) Fish Migration (MIGR) Preservation of Rare and Endangered Species (RARE) Fish Spawning (SPWN) Warm Freshwater Habitat (WARM) Wildlife Habitat (WILD) Water Contact Recreation (REC1) Non-Contact Water Recreation (REC2)

- 3.3.2. **National Toxics Rule (NTR) and California Toxics Rule (CTR).** The NTR and CTR contain federal water quality criteria for priority pollutants. U.S. EPA adopted the NTR on December 22, 1992, and amended it on May 4, 1995, and November 9, 1999. About 40 NTR criteria apply in California. U.S. EPA adopted the CTR on May 18, 2000. The CTR promulgated new toxics criteria for California and incorporated the NTR criteria that applied in the State. U.S. EPA amended the CTR on February 13, 2001.
- 3.3.3. **State Implementation Policy.** On March 2, 2000, the State Water Board adopted the *Policy for Implementation of Toxics Standards for Inland Surface Waters, Enclosed Bays, and Estuaries of California* (State Implementation Policy or SIP). The SIP establishes implementation provisions for priority pollutant criteria and objectives, and provisions for chronic toxicity control. The SIP became effective on April 28, 2000, with respect to the priority pollutant criteria U.S. EPA promulgated for California through the NTR and the priority pollutant objectives the Regional Water Board established through the Basin Plan. The SIP became effective on May 18, 2000, with respect to the priority pollutant criteria U.S. EPA promulgated through the CTR. The State Water Board adopted amendments to the SIP on February 24, 2005, that became effective on July 13, 2005. Requirements of this Order implement the SIP.
- 3.3.4. **Mercury Provisions.** On May 2, 2017, the State Water Board adopted Resolution 2017-0027, which approved *Final Part 2 of the Water Quality Control Plan for Inland Surface Waters, Enclosed Bays, and Estuaries of California – Tribal and Subsistence Fishing Beneficial Uses and Mercury Provisions* (Mercury Provisions), thereby establishing water quality objectives for mercury in most State waters. The Mercury Provisions establish mercury fish tissue water quality objectives based on beneficial uses and translate those objectives

into mercury water column criteria. The water quality objectives supersede the four-day average freshwater mercury objective in Basin Plan Table 3-4. Requirements of this Order implement the Mercury Provisions.

- 3.3.5. **Domestic Water Quality.** In accordance with Water Code section 106.3, it is the policy of the State of California that every human being has the right to safe, clean, affordable, and accessible water adequate for human consumption, cooking, and sanitary purposes. This Order advances that policy by requiring discharges to meet maximum contaminant levels (MCLs) designed to protect human health and ensure that water is safe for domestic use.
- 3.3.6. **Antidegradation Policy.** Federal regulations at 40 C.F.R. section 131.12 require that state water quality standards include an antidegradation policy consistent with the federal policy. The State Water Board established California's antidegradation policy through State Water Board Resolution 68-16, *Statement of Policy with Respect to Maintaining High Quality of Waters in California*, which incorporates the federal antidegradation policy where the federal policy applies under federal law. Resolution No. 68-16 requires that existing water quality be maintained unless degradation is justified based on specific findings. The Basin Plan implements, and incorporates by reference, both the State and federal antidegradation policies. Permitted discharges must be consistent with the antidegradation provisions of 40 C.F.R. section 131.12 and State Water Board Resolution 68-16.
- 3.3.7. **Anti-Backsliding Requirements.** CWA sections 402(o) and 303(d)(4) and 40 C.F.R. section 122.44(l) restrict backsliding in NPDES permits. These anti-backsliding provisions require that effluent limitations in a reissued permit be as stringent as those in the previous permit, with some exceptions in which limitations may be relaxed.
- 3.3.8. **Endangered Species Act Requirements.** This Order does not authorize any act that results in the taking of a threatened or endangered species or any act that is now prohibited, or becomes prohibited in the future, under either the California Endangered Species Act (Fish and Game Code §§ 2050 to 2097) or Federal Endangered Species Act (16 U.S.C.A. §§ 1531 to 1544). This Order requires compliance with effluent limits, receiving water limits, and other requirements to protect the beneficial uses of waters of the State, including protecting rare, threatened, or endangered species. The Discharger is responsible for meeting all applicable Endangered Species Act requirements.
- 3.4. **Impaired Water Bodies on CWA section 303(d) List.** On April 6, 2018, U.S. EPA approved a revised list of impaired waters pursuant to CWA section 303(d), which requires identification of specific water bodies where it is expected that water quality standards will not be met after implementation of technology-based effluent limitations on point sources. Where it has not done so already, the Regional Water Board plans to adopt total maximum daily loads (TMDLs) for pollutants on the 303(d) list. TMDLs establish wasteload allocations for point

sources and load allocations for nonpoint sources and are established to achieve water quality standards.

San Pablo Creek is listed as impaired by diazinon, a pesticide. Basin Plan section 7.1.1 contains a diazinon and pesticide-related toxicity TMDL for San Pablo Creek. The Facility is not a source of pesticide-related toxicity; therefore, the TMDL does not contain a specific wasteload allocation or other implementation requirements for the Facility.

San Pablo Reservoir, downstream of San Pablo Creek, is listed as impaired by chlordane, dieldrin, heptachlor epoxide, mercury, PCBs, and toxaphene. As discussed in Fact sheet section 4.3.3, the discharge is not a source of chlordane, dieldrin, heptachlor epoxide, PCBs, or toxaphene because concentrations of these pollutants have not been detected in Facility discharges. The Facility is an insignificant source of mercury because background and discharge concentrations are consistently at least one order magnitude below water quality objectives. TMDL wasteload allocations have not been established for San Pablo Reservoir.

#### **4. RATIONALE FOR EFFLUENT LIMITATIONS AND DISCHARGE SPECIFICATIONS**

The CWA requires point source dischargers to control the amount of conventional, non-conventional, and toxic pollutants discharged into waters of the United States. The control of pollutants discharged is established through effluent limitations and other requirements in NPDES permits. There are two principal bases for effluent limitations: 40 C.F.R. section 122.44(a) requires that permits include applicable technology-based limitations and standards, and 40 C.F.R. section 122.44(d) requires that permits include water quality-based effluent limitations to attain and maintain applicable numeric and narrative water quality criteria to protect the beneficial uses of receiving waters.

##### **4.1. Discharge Prohibitions**

###### **4.1.1. Prohibitions in this Order**

- 4.1.1.1. **Discharge Prohibition 3.1 (No discharge other than as described):** This prohibition is based on 40 C.F.R. section 122.21(a) and Water Code section 13260, which require filing an application and Report of Waste Discharge before a discharge can occur. Discharges not described in the application and Report of Waste Discharge, and subsequently in this Order, are prohibited. (Some Facility discharges may be covered under the statewide NPDES Permit for Drinking Water System Discharges to Waters of the United States, State Water Board Order No. WQ-2014-0194-DWQ.)
- 4.1.1.2. **Discharge Prohibition 3.2 (No bypass to waters of the United States):** This prohibition is based on 40 C.F.R. section 122.41(m) (see Attachment D section 1.7).



4.1.2. **Basin Plan Discharge Prohibition 1.** Basin Plan Table 4-1, Discharge Prohibition 1, prohibits discharges to any non-tidal water. Discharge Point 003 discharges to San Pablo Creek, a non-tidal water. In accordance with Basin Plan section 4.2, which provides for exceptions to Basin Plan Discharge Prohibition 1, this Order grants an exception when not discharging is infeasible. The circumstances under which Basin Plan section 4.2 allows for exceptions are as follows:

- An inordinate burden would be placed on the Discharger relative to the beneficial uses protected, and an equivalent level of environmental protection can be achieved by alternate means;
- A discharge is approved as part of a reclamation project;
- Net environmental benefits will be derived as a result of the discharge; or
- A discharge is approved as part of a groundwater cleanup project.

The Basin Plan further states:

In reviewing requests for exceptions, the Water Board will consider the reliability of the discharger's system in preventing inadequately treated wastewater from being discharged to the receiving water and the environmental consequences of such discharges.

This Order grants an exception to Basin Plan Discharge Prohibition 1 for the following reasons:

- An inordinate burden would be placed on the Discharger relative to the beneficial uses protected if this Order were to require discharge to non-tidal waters (i.e., San Pablo Bay or San Francisco Bay) due to the necessary construction and operation of a discharge pipe many miles long. Moreover, the discharge to San Pablo Creek is a necessary part of EBMUD's drinking water system that provides safe potable water to all or parts of Alameda, Albany, Berkeley, El Cerrito, Emeryville, Moraga, Oakland, Orinda, Piedmont, Richmond, and San Leandro. Discharge to tidal waters would waste this important resource.
- An equivalent level of environmental protection is provided because Provision 6.3.2 of this Order requires the Discharger to maintain and implement a Best Management Practices (BMPs) Plan that describes measures and safeguards that minimize the discharge of pollutants. This is adequate for this Facility in consideration of the high quality of the Discharger's influent water source.

## 4.2. Technology-Based Effluent Limitations

### 4.2.1. Scope and Authority

CWA section 301(b) and 40 C.F.R. section 122.44 require that permits include conditions meeting technology-based requirements, at a minimum, and any more stringent effluent limitations necessary to meet water quality standards. The CWA requires that technology-based effluent limitations be established based on several levels of control:

- **Best practicable treatment control technology (BPT).** BPT represents the average of the best existing performance by well-operated plants within an industrial category or subcategory. BPT standards apply to toxic, conventional, and non-conventional pollutants.
- **Best available technology economically achievable (BAT).** BAT represents the best existing performance of treatment technologies that are economically achievable within an industrial point source category. BAT standards apply to toxic and non-conventional pollutants.
- **Best conventional pollutant control technology (BCT).** BCT represents the control from existing industrial point sources of conventional pollutants including biochemical oxygen demand (BOD), TSS, fecal coliform, pH, and oil and grease. BCT standards are established after considering a two-part reasonableness test. The first test compares the relationship between the cost of attaining a reduction in effluent discharge and the resulting benefits. The second test examines the cost and level of reduction of pollutants from the discharge from publicly owned treatment works to the cost and level of reduction of such pollutants from a class or category of industrial sources. Effluent limitations must be reasonable under both tests.
- **New source performance standards (NSPS).** NSPS represent the best available demonstrated control technology standards. The intent of NSPS guidelines is to set limitations that represent state-of-the-art treatment technology for new sources.

The CWA requires U.S. EPA to develop effluent limitations, guidelines, and standards representing these levels of control, and CWA section 402(a)(1) and 40 C.F.R. section 125.3 authorize the use of best professional judgment when U.S. EPA has not done so. U.S. EPA has not developed effluent limitations, guidelines, and standards for the type of industry represented by the Facility. However, effluent limitations based on best professional judgment are unnecessary because Basin Plan Table 4-2 specifies sufficient technology-based controls.

#### 4.2.2. Effluent Limitations

- 4.2.2.1. **Total Suspended Solids (TSS).** The TSS effluent limitations are based on Basin Plan Table 4-2. While these limitations were developed primarily for wastewater treatment plants, they also apply for other discharges. They are necessary to ensure the Facility adequately removes suspended solids before discharge.
- 4.2.2.2. **Settleable Matter.** The settleable matter effluent limitations are based on Basin Plan Table 4-2. They are necessary to ensure that the Facility adequately removes settleable matter before discharge.
- 4.2.2.3. **pH.** The pH effluent limitations are based on Basin Plan Table 4-2. These technology-based controls also implement the pH water quality objective in Basin Plan section 3.3.9.
- 4.2.2.4. **Total Residual Chlorine.** The total residual chlorine effluent limitation is based on Basin Plan Table 4-2. The Monitoring and Reporting Program (MRP, Attachment E) provides an allowance for determining false positives when using continuous devices based on the fact that continuous instruments occasionally have anomalous spikes, and it is chemically improbable to have free chlorine in the presence of sodium bisulfite. The allowance for using only on-the-hour measurements for mandatory minimum penalty assessment purposes under Water Code section 13385.1 is based on a 2004 strategy developed between the Regional Water Board and the Bay Area Clean Water Agencies.

#### 4.3. Water Quality-Based Effluent Limitations

##### 4.3.1. Scope and Authority

CWA section 301(b) and 40 C.F.R. section 122.44(d) require permits to include limitations more stringent than federal technology-based requirements where necessary to achieve water quality standards. According to 40 C.F.R. section 122.44(d)(1)(i), permits must include effluent limitations for all pollutants that are or may be discharged at levels that have a reasonable potential to cause or contribute to an exceedance of a water quality standard, including numeric and narrative objectives within a standard. Where reasonable potential has been established for a pollutant, but there is no numeric criterion or objective, WQBELs must be established using (1) U.S. EPA criteria guidance under CWA section 304(a), supplemented where necessary by other relevant information; (2) an indicator parameter for the pollutant of concern; or (3) a calculated numeric water quality criterion, such as a proposed state criterion or policy interpreting a narrative criterion, supplemented with relevant information. The process for determining reasonable potential and calculating WQBELs when necessary is intended to achieve applicable water quality objectives and criteria, and thereby protect designated beneficial uses of receiving waters.

#### 4.3.2. Beneficial Uses and Water Quality Criteria and Objectives

Discharge Point 003 discharges to San Pablo Creek. Fact Sheet section 3.3.1 identifies the beneficial uses of San Pablo Creek. Water quality criteria and objectives to protect these beneficial uses are described below.

- 4.3.2.1. **Basin Plan Objectives.** The Basin Plan specifies numeric water quality objectives for many pollutants, including pollutants to protect aquatic life and municipal drinking water supplies (see Basin Plan sections 3.3.21 and 3.3.22). The Basin Plan also specifies narrative water quality objectives. The toxicity objective in Basin Plan section 3.3.18 states, “All waters shall be maintained free of toxic substances in concentrations that are lethal to or that produce other detrimental responses in aquatic organisms.”
- 4.3.2.2. **CTR Criteria.** The CTR specifies numeric aquatic life and human health criteria for numerous priority pollutants. These criteria apply to inland surface waters and enclosed bays and estuaries. Some human health criteria are for consumption of “water and organisms” and others are for consumption of “organisms only.” The criteria applicable to “water and organisms” apply to San Pablo Creek because municipal and domestic supply (MUN) is designated as a beneficial use.
- 4.3.2.3. **NTR Criteria.** The NTR establishes numeric aquatic life and human health criteria for a number of toxic pollutants for San Francisco Bay waters upstream to and including Suisun Bay and the Sacramento-San Joaquin Delta. The NTR criteria apply to San Pablo Creek.
- 4.3.2.4. **Mercury Objectives.** The Mercury Provisions specify mercury fish tissue water quality objectives based on beneficial uses, and the implementing provisions translate those objectives into mercury water column criteria depending on water body type and beneficial uses. The Mercury Provisions specify water column criteria for mercury depending on water body type and beneficial uses. San Pablo Creek is a flowing water body that supports cold freshwater habitat; warm freshwater habitat, fish migration; preservation of rare, threatened, or endangered species; fish spawning, and wildlife habitat beneficial uses. Therefore, pursuant to Table 1 of the Mercury Provisions, the applicable water column mercury criterion is 12 ng/l.
- 4.3.2.5. **Receiving Water Salinity.** Basin Plan section 4.6.2 (like the CTR and NTR) states that the salinity characteristics (i.e., freshwater vs. saltwater) of the receiving water are to be considered in determining the applicable water quality objectives. Freshwater criteria apply to discharges to waters with salinities equal to or less than one part per thousand (ppt) at least 95 percent of the time. Saltwater criteria apply to discharges to waters with salinities equal to or greater than 10 ppt at least 95 percent of the time in a normal water year. For discharges to water with salinities in between these two categories, or tidally-influenced freshwaters that support estuarine beneficial

uses, the water quality objectives are the lower of the salt or freshwater criteria (the latter calculated based on ambient hardness) for each substance.

San Pablo Creek is a freshwater creek based on salinity data generated through the Surface Water Ambient Monitoring Program (SWAMP). Salinity data were collected at the Orinda Village (206SPA220) and Lauterwasser Creek (206SPA200) sampling locations on September 19, 2001. Because the salinity was equal to or less than 1 ppt in 100 percent of the samples, San Pablo Creek is classified as freshwater, and the reasonable potential analysis and WQBELs are based on freshwater water quality criteria and objectives.

4.3.2.6. **Receiving Water Hardness.** An ambient hardness of 290 mg/L as CaCO<sub>3</sub> was used to calculate freshwater quality objectives that are hardness-dependent based on two samples collected in San Pablo Creek upstream of Discharge Point 003 on January 26, 2012, that were reported in the 2012 Annual Self-Monitoring Report.

4.3.2.7. **Metals Translators.** Regulations at 40 C.F.R. section 122.45(c), require effluent limitations for metals to be expressed as total recoverable metal. Since the water quality objectives for metals are typically expressed as dissolved metal, translators must be used to convert metals concentrations from dissolved to total recoverable and vice versa. The CTR contains default translators; however, site-specific conditions, such as water temperature, pH, total suspended solids, and organic carbon may affect the form of metal (dissolved, non-filterable, or otherwise) present and therefore available to cause toxicity. In general, dissolved metals are more available and more toxic to aquatic life than other forms. Site-specific translators can account for site-specific conditions, thereby preventing overly stringent or under-protective water quality objectives.

CTR default translators were used for all metals in this Order's reasonable potential analysis.

#### 4.3.3. Reasonable Potential Analysis

4.3.3.1. **Available Information.** The reasonable potential analysis for this Order is based on effluent monitoring data and ambient background data the Discharger collected from December 2009 through December 2014, and more recent dichlorobromomethane effluent and ambient background data collected from January 2016 through January 2021.

In some cases, reasonable potential cannot be determined because effluent data are limited, or ambient background concentrations are unavailable. The MRP requires the Discharger to monitor for these constituents in its effluent using analytical methods that provide the best feasible detection limits as

needed to inform future permit development. When additional data become available, further analysis will be conducted to determine whether numeric effluent limitations are necessary.

This Order does not contain WQBELs for constituents that do not demonstrate reasonable potential.

4.3.3.2. **Priority Pollutants.** SIP section 1.3 sets forth the methodology used to assess whether priority pollutants have reasonable potential to exceed CTR and NTR water quality objectives. Here, SIP section 1.3 is also used as guidance to assess whether priority pollutants have reasonable potential to exceed water quality objectives designed to protect municipal supply (i.e., maximum contaminant levels).

The analysis begins with identifying the maximum effluent concentration (MEC) observed for each pollutant based on available effluent concentration data and the ambient background concentration (B). SIP section 1.4.3 states that ambient background concentrations are either the maximum ambient concentration observed or, for water quality objectives intended to protect human health, the arithmetic mean of observed concentrations. There are three triggers in determining reasonable potential:

- **Trigger 1** is activated if the maximum effluent concentration is greater than or equal to the lowest applicable water quality objective ( $MEC \geq$  water quality objective).
- **Trigger 2** is activated if the ambient background concentration observed in the receiving water is greater than the lowest applicable water quality objective ( $B >$  water quality objective) and the pollutant is detected in any effluent sample.
- **Trigger 3** is activated if a review of other information indicates that a WQBEL is needed to protect beneficial uses.

The maximum effluent concentrations, most stringent applicable water quality criteria and objectives, and ambient background concentrations used in the analysis are presented in the following table, along with the reasonable potential analysis results (yes, no, or unknown) for each priority pollutant. Based on this analysis, the only priority pollutant that demonstrates reasonable potential is dichlorobromomethane.

**Table F-5. Reasonable Potential Analysis for Priority Pollutants**

CTR No.	Pollutant	C or Governing Criterion or Objective (µg/L)	MEC or Minimum DL (µg/L) <sup>[1][2]</sup>	B or Minimum DL (µg/L) <sup>[1][2]</sup>	RPA Result <sup>[3]</sup>
1	Antimony	6.0	< 0.30	0.30	No

CTR No.	Pollutant	C or Governing Criterion or Objective (µg/L)	MEC or Minimum DL (µg/L) <sup>[1][2]</sup>	B or Minimum DL (µg/L) <sup>[1][2]</sup>	RPA Result <sup>[3]</sup>
2	Arsenic	10	0.44	3.1	No
3	Beryllium	4.0	< 0.041	< 0.030	No
4	Cadmium	2.6	< 0.051	< 0.020	No
5a	Chromium (III)	50	< 0.20 <sup>[4]</sup>	< 0.40 <sup>[4]</sup>	No
5b	Chromium (VI)	11	< 0.20 <sup>[4]</sup>	< 0.40 <sup>[4]</sup>	No
6	Copper	23	1.6	2.0	No
7	Lead	12	< 0.3	< 0.051	No
8	Mercury	0.012	0.0024	0.0017	No
9	Nickel	100	0.49	3.3	No
10	Selenium	5.0	< 0.030	< 0.040	No
11	Silver	25	< 0.081	< 0.071	No
12	Thallium	1.7	< 0.61	< 0.20	No
13	Zinc	300	< 1.0	1.4	No
14	Cyanide	5.2	< 0.0030	< 0.0030	No
15	Asbestos (fibers/L)	7,000,000	< 200,000	< 200,000	No
16	2,3,7,8-TCDD	1.3 x 10 <sup>-8</sup>	<sup>[5]</sup>	<sup>[5]</sup>	No
17	Acrolein	320	< 2.1	< 2.9	No
18	Acrylonitrile	0.059	Unavailable	< 0.42	U
19	Benzene	1.0	< 0.10	< 0.10	No
20	Bromoform	4.3	< 0.18	< 0.18	No
21	Carbon Tetrachloride	0.25	< 0.14	< 0.14	No
22	Chlorobenzene	70	< 0.12	< 0.13	No
23	Chlorodibromomethane	0.40	0.14	< 0.13	No
24	Chloroethane	No Criterion	< 0.18	< 0.18	U
25	2-Chloroethylvinyl ether	No Criterion	< 0.25	< 0.25	U
26	Chloroform	No Criterion	24	< 0.27	U
<b>27</b>	<b>Dichlorobromomethane</b>	<b>0.56</b>	<b>3.4</b>	<b>0.39</b>	<b>Yes</b>
28	1,1-Dichloroethane	5	< 0.13	< 0.13	No
29	1,2-Dichloroethane	0.38	< 0.14	< 0.14	No
30	1,1-Dichloroethylene	0.057	< 0.19	< 0.19	No
31	1,2-Dichloropropane	0.52	< 0.13	< 0.13	No
32	1,3-Dichloropropylene	0.50	< 0.13	< 0.13	No
33	Ethylbenzene	300	< 0.13	< 0.13	No
34	Methyl Bromide	48	< 0.23	< 0.23	No
35	Methyl Chloride	No Criterion	< 0.32	< 0.32	U
36	Methylene Chloride	4.7	0.24	< 0.24	No
37	1,1,2,2-Tetrachloroethane	0.17	< 0.12	< 0.12	No
38	Tetrachloroethylene	0.8	< 0.18	< 0.18	No
39	Toluene	150	0.11	< 0.11	No
40	1,2-Trans-Dichloroethylene	10	< 0.19	< 0.19	No
41	1,1,1-Trichloroethane	200	< 0.16	< 0.16	No

CTR No.	Pollutant	C or Governing Criterion or Objective (µg/L)	MEC or Minimum DL (µg/L) <sup>[1][2]</sup>	B or Minimum DL (µg/L) <sup>[1][2]</sup>	RPA Result <sup>[3]</sup>
42	1,1,2-Trichloroethane	0.60	< 0.20	< 0.20	No
43	Trichloroethylene	2.7	< 0.4	< 0.2	No
44	Vinyl Chloride	0.5	< 0.090	< 0.090	No
45	2-Chlorophenol	120	< 0.55	< 0.56	No
46	2,4-Dichlorophenol	93	< 0.60	< 0.61	No
47	2,4-Dimethylphenol	540	< 0.36	< 0.36	No
48	2-Methyl- 4,6-Dinitrophenol	13	< 0.97	< 0.98	No
49	2,4-Dinitrophenol	70	< 0.97	< 0.98	No
50	2-Nitrophenol	No Criterion	< 0.49	< 0.50	U
51	4-Nitrophenol	No Criterion	< 1.8	< 1.9	U
52	3-Methyl 4-Chlorophenol	No Criterion	< 0.55	< 0.56	U
53	Pentachlorophenol	0.28	< 1.7	< 1.8	No
54	Phenol	21,000	< 0.94	< 0.95	No
55	2,4,6-Trichlorophenol	2.1	< 0.58	< 0.59	No
56	Acenaphthene	1,200	< 0.45	< 0.039	No
57	Acenaphthylene	No Criterion	< 0.43	< 0.43	U
58	Anthracene	9,600	< 0.34	< 0.064	No
59	Benzidine	0.00012	< 4.8	< 4.9	No
60	Benzo(a)Anthracene	0.0044	< 0.51	< 0.020	No
61	Benzo(a)Pyrene	0.0044	< 0.46	< 0.044	No
62	Benzo(b)Fluoranthene	0.0044	< 0.48	< 0.031	No
63	Benzo(ghi)Perylene	No Criterion	< 0.71	< 0.023	U
64	Benzo(k)Fluoranthene	0.0044	< 0.29	< 0.015	No
65	Bis(2-Chloroethoxy)Methane	No Criterion	< 0.54	< 0.55	U
66	Bis(2-Chloroethyl)Ether	0.031	< 0.71	< 0.73	No
67	Bis(2-Chloroisopropyl)Ether	1,400	< 0.53	< 0.54	No
68	Bis(2-Ethylhexyl)Phthalate	1.8	< 1.2	< 1.3	No
69	4-Bromophenyl Phenyl Ether	No Criterion	< 0.61	< 0.62	U
70	Butylbenzyl Phthalate	3,000	< 0.64	< 0.65	No
71	2-Chloronaphthalene	1,700	< 0.47	< 0.48	No
72	4-Chlorophenyl Phenyl Ether	No Criterion	< 0.58	< 0.59	U
73	Chrysene	0.0044	< 0.48	< 0.017	No
74	Dibenzo(a,h)Anthracene	0.0044	< 0.53	< 0.016	No
75	1,2-Dichlorobenzene	600	< 0.13	< 0.13	No
76	1,3-Dichlorobenzene	400	< 0.17	< 0.17	No
77	1,4-Dichlorobenzene	5.0	< 0.15	< 0.15	No
78	3,3 Dichlorobenzidine	0.040	< 0.57	< 0.58	No
79	Diethyl Phthalate	23,000	0.40	< 0.40	No
80	Dimethyl Phthalate	310,000	< 0.18	< 0.19	No
81	Di-n-Butyl Phthalate	2,700	3.6	< 0.86	No
82	2,4-Dinitrotoluene	0.11	< 0.46	< 0.50	No



CTR No.	Pollutant	C or Governing Criterion or Objective (µg/L)	MEC or Minimum DL (µg/L) <sup>[1][2]</sup>	B or Minimum DL (µg/L) <sup>[1][2]</sup>	RPA Result <sup>[3]</sup>
83	2,6-Dinitrotoluene	No Criterion	< 0.46	< 0.47	U
84	Di-n-Octyl Phthalate	No Criterion	< 0.97	< 0.98	U
85	1,2-Diphenylhydrazine	0.040	< 0.48	Unavailable	No
86	Fluoranthene	300	< 0.53	< 0.027	No
87	Fluorene	1,300	< 0.44	< 0.049	No
88	Hexachlorobenzene	0.00075	< 0.49	< 0.50	No
89	Hexachlorobutadiene	0.44	< 0.55	< 0.56	No
90	Hexachlorocyclopentadiene	50	< 3.1	< 3.1	No
91	Hexachloroethane	1.9	< 0.50	< 0.49	No
92	Indeno(1,2,3-cd)Pyrene	0.0044	< 0.50	< 0.016	No
93	Isophorone	8.4	< 0.56	< 0.57	No
94	Naphthalene	No Criterion	< 0.53	< 0.071	U
95	Nitrobenzene	17	< 0.69	< 0.70	No
96	N-Nitrosodimethylamine	0.00069	< 0.72	< 0.74	No
97	N-Nitrosodi-n-Propylamine	0.0050	< 0.8	< 0.81	No
98	N-Nitrosodiphenylamine	5.0	< 0.58	Unavailable	No
99	Phenanthrene	No Criterion	< 0.43	< 0.042	U
100	Pyrene	960	< 0.018	< 0.029	No
101	1,2,4-Trichlorobenzene	5.0	< 0.49	< 0.51	No
102	Aldrin	0.00013	< 0.0017	< 0.0029	No
103	Alpha-BHC	0.0039	< 0.0030	< 0.0029	No
104	Beta-BHC	0.014	< 0.0045	< 0.0029	No
105	Gamma-BHC	0.019	< 0.0028	< 0.0020	No
106	Delta-BHC	No Criterion	< 0.0029	< 0.0029	U
107	Chlordane	0.00057	< 0.013	< 0.014	No
108	4,4'-DDT	0.00059	< 0.0036	< 0.0039	No
109	4,4'-DDE	0.00059	< 0.0024	< 0.0029	No
110	4,4'-DDD	0.00083	< 0.0021	< 0.0020	No
111	Dieldrin	0.00014	< 0.0021	< 0.0039	No
112	Alpha-Endosulfan	0.056	< 0.0023	< 0.0039	No
113	beta-Endosulfan	0.056	< 0.0026	< 0.0039	No
114	Endosulfan Sulfate	110	< 0.0033	< 0.0020	No
115	Endrin	0.036	< 0.0021	< 0.0029	No
116	Endrin Aldehyde	0.76	< 0.0037	< 0.0039	No
117	Heptachlor	0.00021	< 0.0029	< 0.0029	No
118	Heptachlor Epoxide	0.00010	< 0.0021	< 0.0029	No
119-125	PCBs sum	0.00017	< 0.55 <sup>[6]</sup>	< 0.50 <sup>[6]</sup>	No
126	Toxaphene	0.00020	< 0.068	< 0.071	No

Footnotes:

<sup>[1]</sup> The MEC and ambient background concentration are the actual detected concentrations unless preceded by a "<" sign, in which case the value shown is the minimum detection level (MDL).

- <sup>[2]</sup> The MEC or ambient background concentration is “Unavailable” when there are no monitoring data for the constituent.
- <sup>[3]</sup> RPA Results = Yes, if MEC  $\geq$  WQC, B > WQC and MEC is detected, or Trigger 3  
= No, if MEC and B are < WQC or all effluent data are undetected  
= Unknown (U) if no criteria have been promulgated or data are insufficient.
- <sup>[4]</sup> Chromium (III) and chromium (VI) data are unavailable. The result shown is for total recoverable chromium.
- <sup>[5]</sup> All dioxin and furan congener concentrations were below the detection limit.
- <sup>[7]</sup> Each PCB congener concentration was below the detection limit.

4.3.3.3. **Other Pollutants.** Basin Plan section 3.3.22 specifies that the maximum contaminant levels for drinking water are water quality objectives for waters with the MUN beneficial use. Priority pollutants with maximum contaminant levels are discussed in Fact Sheet section 4.3.3.2, above. Non-priority pollutants with maximum contaminant levels have no reasonable potential because the Discharger manages the Facility, San Pablo Reservoir, nearby portions of San Pablo Creek, and other water treatment facilities to comply with maximum contaminant levels per State regulations and State Water Board Division of Drinking Water permits (*East Bay Municipal Utility District 2019 Annual Water Quality Report*).

4.3.3.4. **Acute Toxicity.** Basin Plan section 4.5.5.3.1 requires acute toxicity monitoring and limitations, implying there is reasonable potential for the discharge to cause or contribute to exceedances of the acute toxicity water quality objective.

#### 4.3.4. **Water Quality-Based Effluent Limitations**

WQBELs were developed for the pollutants determined to have reasonable potential to cause or contribute to exceedances of water quality objectives.

4.3.4.1. **Dichlorobromomethane.** The source of dichlorobromomethane in the Facility’s effluent is the water it receives from the Mokelumne Aqueduct, which is chlorinated upstream of the Facility to control bacteria and algae growth. Trihalomethanes, including dichlorobromomethane, are formed when chlorine reacts with organic matter in water. The formation of trihalomethanes depends on a number of variables, such as temperature, organic substrate availability, and chlorine contact time.

Dichlorobromomethane is a contaminant commonly present in potable water supplies, and the levels in the discharge generally meet standards for drinking water (total trihalomethanes of 80  $\mu\text{g/L}$ ). However, to protect human health from potential exposure to dichlorobromomethane in San Pablo Creek and San Pablo Reservoir, the CTR contains a more stringent water quality criterion of 0.56  $\mu\text{g/L}$  for waters where both water and organisms are consumed.

4.3.4.1.1. **Mixing Zone and Dilution Credit.** The Basin Plan and SIP section 1.4.2 allow mixing zones and dilution credits for completely-mixed discharges and, under certain circumstances, incompletely-mixed discharges. This

Order authorizes a mixing zone and dilution credit for dichlorobromomethane based on SIP procedures for incompletely-mixed discharges, as discussed below. The SIP allows mixing zones and dilution credits to be based on the procedures for incompletely-mixed discharges if the procedures for completely-mixed discharges are inappropriate due to site-specific issues. Here, the site-specific issues are as follows:

- The allowance of a mixing zone is appropriate because the water quality objective at issue relates to the protection of water to support municipal supply, but the pollutant itself is the direct result of operations required and necessary to meet the public demand for potable water.
- Using the SIP procedures for completely-mixed discharges would result in an overly conservative dilution credit due to the high variability in San Pablo Creek flows, which are usually less than discharge flows. Meaningful dilution does not occur until the combined flow of the discharge and creek reaches San Pablo Reservoir.
- The total trihalomethanes drinking water standard (80 µg/L) will be maintained throughout the entirety of any dichlorobromomethane mixing zone. Dichlorobromomethane is one of four pollutants that make up the total trihalomethanes drinking water standard. The other three trihalomethanes are chloroform, bromoform, and chlorodibromomethane. The maximum effluent concentration of dichlorobromomethane observed is 3.4 µg/L. The maximum concentration of chloroform observed is 24 µg/L. Bromoform and chlorodibromomethane have not been detected in the effluent. Under a worst-case scenario (i.e., when the maximum effluent concentrations of all four trihalomethanes occur at the same time), the total trihalomethanes concentration would still be below 80 µg/L.

The Discharger completed a mixing zone study, *Effluent Mixing Zone / Dilution Credits Study* (October 12, 2012), to justify a dichlorobromomethane mixing zone. The study used effluent and receiving water monitoring data to characterize the extent of dilution within San Pablo Creek and San Pablo Reservoir. The analysis demonstrated that a hypothetical dichlorobromomethane mixing zone extending from Discharge Point 003 to a point 2.4 miles downstream in San Pablo Reservoir (see Attachment B) corresponds to a dilution ratio of 23:1.

The hypothetical dichlorobromomethane mixing zone is assessed below and shown to meet all the requirements of SIP section 1.4.2.2.A. SIP section 1.4.2.2 requires mixing zones to be as small as practicable. If the Discharger can comply with a mixing zone smaller than the hypothetical mixing zone, then the smaller mixing zone is practicable. Moreover, if the hypothetical mixing zone meets all the requirements of SIP section 1.4.2.2.A, a smaller mixing zone must as well. This Order authorizes a

smaller mixing zone corresponding to a dilution ratio of 16.5:1 (D=15.5) because the Discharger can comply with WQBELs based on this smaller mixing zone. The hypothetical mixing zone would meet the requirements of SIP section 1.4.2.2.A because it would not do any of the following:

- 4.3.4.1.1.1. **Compromise the integrity of the water body.** At 18.7 miles long, San Pablo Creek drains a watershed area of 41 square miles above San Pablo Reservoir. The mixing zone encompasses 1.0 mile of the creek, or about five percent of the creek above the reservoir. San Pablo Reservoir is 4.2 miles long and has an average surface area of 720 acres and average volume of 12.5 billion gallons of water. The mixing zone comprises a maximum of seven percent of the reservoir volume. Because the mixing zone would occupy relatively small areas and volumes of San Pablo Creek and San Pablo Reservoir, it would not compromise the integrity of these waters.
- 4.3.4.1.1.2. **Cause acutely toxic conditions to aquatic life passing through the mixing zone.** The mixing zone would not cause acutely toxic conditions to aquatic life because dichlorobromomethane poses little threat to aquatic organisms at the concentrations discharged. Neither the CTR nor the Basin Plan has a water quality objective to protect aquatic life from dichlorobromomethane. Moreover, U.S. EPA has not recommended a water quality criterion for dichlorobromomethane to protect aquatic life. The State Water Board's Compilation of Water Quality Goals refers to 11,000 µg/L total trihalomethanes as the lowest observable effects level for freshwater aquatic life, which is far above the effluent concentrations observed. Therefore, no acutely toxic effects would be expected from dichlorobromomethane within the mixing zone.  
  
Moreover, this Order requires acute toxicity testing to demonstrate compliance with acute toxicity effluent limitations. These limitations do not account for dilution; therefore, compliance with these limits ensures that acutely toxic conditions will not exist inside the mixing zone.
- 4.3.4.1.1.3. **Restrict the passage of aquatic life.** As described above, the discharge will not cause acutely toxic conditions to aquatic life, so it would not threaten aquatic life passing through the mixing zone. Moreover, dichlorobromomethane is not viscous and does not affect water clarity, so it cannot create a physical or visual barrier that could restrict the passage of aquatic life.
- 4.3.4.1.1.4. **Adversely impact biologically sensitive or critical habitats, including, but not limited to, habitats of species under federal or State endangered species laws.** The mixing zone would not harm biologically sensitive or critical habitats because discharges from the Facility have been occurring for many years without any adverse impacts to biologically sensitive or critical habitats. Surveys conducted

on the eastern side of San Pablo Reservoir and within San Pablo Creek have not identified the presence of red-legged frogs (the only potential species of concern in the area of the discharge). The closest red-legged frog sightings have been in the education pond at Wagner Ranch School, downstream of the Facility. Red-legged frogs may use San Pablo Creek for brief periods, as they move between pond and creek habitats in the area; however, they do not tend to stay in San Pablo Creek due to the presence of largemouth bass, bullfrogs, and other predators. Dichlorobromomethane is not known to harm frogs or any other aquatic life at the concentrations discharged.

- 4.3.4.1.1.5. **Produce undesirable or nuisance aquatic life.** Dichlorobromomethane is not a biostimulant or plant nutrient so it does not cause growth of aquatic nuisance species. The Facility's discharges have occurred for many years without producing undesirable or nuisance aquatic life. Moreover, this Order contains receiving water limitations that prohibit bottom deposits and aquatic growths to the extent that such deposits or growth cause nuisance or adversely affect beneficial uses.
- 4.3.4.1.1.6. **Result in floating debris, oil, or scum.** The mixing zone would not result in floating debris, oil, or scum because dichlorobromomethane is not an oil, does not float, and does not cause scum. The low dichlorobromomethane concentrations in the discharge are completely dispersed within the discharge. Moreover, this Order contains receiving water limitations that prohibit floating debris, oil, or scum at any place and at any time.
- 4.3.4.1.1.7. **Produce objectionable color, odor, taste, or turbidity.** Dichlorobromomethane at discharge concentrations cannot significantly affect color, odor, taste, or turbidity. Dichlorobromomethane is a colorless, clear liquid so it would not produce objectionable color or turbidity in the mixing zone. A study of rats fed varying dichlorobromomethane concentrations found a taste-aversion threshold of 700 parts per million (ppm). For humans, the odor threshold is 1,680 milligrams per cubic meter. Dichlorobromomethane discharge concentrations are several orders of magnitude below the taste and odor thresholds.
- 4.3.4.1.1.8. **Cause objectionable bottom deposits.** The mixing zone would not cause objectionable bottom deposits because dichlorobromomethane does not readily bind to sediment or persist in the environment. The SIP defines objectionable bottom deposits as an accumulation of materials or substances on or near the bottom of a water body that creates conditions adversely affecting aquatic life, human health, beneficial uses, or aesthetics. These conditions include, but are not limited to, the accumulation of pollutants in sediment and other conditions that result

in harm to benthic organisms, production of food chain organisms, or fish egg development. This Order contains receiving water limitations that prohibit bottom deposits or aquatic growths to the extent that such deposits or growths cause nuisance or adversely affect beneficial uses. Discharges of settled filter backwash water have occurred for many years without causing objectionable bottom deposits.

4.3.4.1.1.9. **Cause nuisance.** The mixing zone would not cause a nuisance because dichlorobromomethane is colorless and odorless at discharge concentrations. Water Code section 13050(m) defines “nuisance” to mean anything that meets all three of the following criteria:

- Is injurious to health, or is indecent or offensive to the senses, or an obstruction to the free use of property, so as to interfere with the comfortable enjoyment of life or property;
- Affects at the same time an entire community or neighborhood, or any considerable number of persons, although the extent of the annoyance or damage inflicted upon individuals may be unequal; and
- Occurs during, or as a result of, the treatment or disposal of wastes.

The mixing zone would not be injurious to health because drinking water standards would continue to be maintained within it. Likewise, the water quality objective that protects human health from fish consumption (46 µg/L) would also be maintained within the mixing zone. The mixing zone would not result in dichlorobromomethane concentrations that are indecent or offensive to the senses and would not interfere with the comfortable enjoyment of life or property because the dichlorobromomethane in the discharges is imperceptible and not harmful to aquatic life or human health. Furthermore, Attachment G section I.I.1 specifically prohibits discharges from causing a nuisance as defined in Water Code section 13050.

4.3.4.1.1.10. **Dominate the receiving water body or overlap a mixing zone from a different outfall.** The dichlorobromomethane mixing zone would not dominate the receiving waters or overlap any other established mixing zones (the Regional Water Board has not established any other mixing zones in these receiving waters). As discussed above, the mixing zone would encompass approximately five percent of the total creek length and a maximum of seven percent of the reservoir volume. Because the mixing zone would occupy relatively small areas and volumes of the receiving waters, it would not dominate them.

4.3.4.1.1.11. **Be located at or near any drinking water intake.** The mixing zone would not be at or near a drinking water intake. The Sobrante Water

Treatment Plant intake is located at the far side of San Pablo Reservoir, opposite the Facility, approximately three miles from the mixing zone boundary. The water quality in this area meets the CTR water quality criterion for dichlorobromomethane of 0.56 µg/L. Therefore, the mixing zone would not affect the use of San Pablo Creek and San Pablo Reservoir as a source of drinking water.

- 4.3.4.1.2. **WQBEL Calculations.** For dichlorobromomethane, the WQBEL calculations are based on the procedures in SIP section 1.4. An average monthly effluent limitation (AMEL) and maximum daily effluent limitation (MDEL) were calculated as shown below:

**Table F-6. WQBEL Calculations**

Pollutant	Dichlorobromomethane
Units	µg/L
Basis and Criteria type	CTR Human Health
CTR Aquatic Life Criteria - Acute	-
CTR Aquatic Life Criteria - Chronic	-
CTR Human Health Criteria - Organisms Only	46
CTR Human Health Criteria - Water & Organisms	0.56
Title 22 Municipal Supply - Primary MCL	-
Title 22 Municipal Supply - Secondary MCL	-
Basin Plan Agricultural Supply	-
Water Effects Ratio (WER)	1
Lowest WQO	0.56
Site Specific Translator - MDEL	-
Site Specific Translator - AMEL	-
Dilution Factor (D)	15.5
No. of samples per month	4
Aquatic life criteria analysis required? (Y/N)	N
HH criteria analysis required? (Y/N)	Y
Applicable Acute WQO	-
Applicable Chronic WQO	-
HH Criteria	0.56
Background (Maximum Conc. for Aquatic Life Calc.)	-
Background (Average Conc. for Human Health Calc.)	0.39
Is the pollutant on the 303d list and/or bioaccumulative (Y/N)?	N
ECA Acute	-
ECA Chronic	-
ECA HH	3.2

Pollutant	Dichlorobromomethane
No. of data points <10 or at least 80% of data reported non-detect? (Y/N)	N
Avg of effluent data points	1.46
Std Dev of effluent data points	0.47
CV Calculated	0.32
CV (Selected) - Final	0.32
ECA Acute Mult99	-
ECA Chronic Mult99	-
LTA Acute	-
LTA Chronic	-
Minimum of LTAs	-
AMEL Mult95	1.28
MDEL Mult99	1.98
AMEL (Aquatic Life)	-
MDEL (Aquatic Life)	-
MDEL/AMEL Multiplier	1.54
AMEL (Human Health)	3.2
MDEL (Human Health)	4.92
Minimum of AMEL for Aq. Life vs HH	3.2
Minimum of MDEL for Aq. Life vs HH	4.9
Previous Order Limit - AMEL	3.2
Previous Order Limit - MDEL	4.4
Final Limit - AMEL	3.2
Final Limit - MDEL	4.4

4.3.4.2 **Acute Toxicity.** This Order includes acute toxicity effluent limitations based on Basin Plan Table 4-3.

#### 4.4. Discharge Requirement Considerations

4.4.1. **Anti-Backsliding.** This Order complies with the anti-backsliding provisions of CWA sections 402(o) and 303(d)(4), and 40 C.F.R. section 122.44(l), which generally require effluent limitations in a reissued permit to be as stringent as those in the previous order. The requirements of this Order are at least as stringent as those in the previous order.

4.4.2. **Antidegradation.** This Order complies with the antidegradation provisions of 40 C.F.R. section 131.12 and State Water Board Resolution 68-16. It does not authorize lowering water quality as compared to the level of discharge



authorized in the previous order, which is the baseline by which to measure whether degradation will occur. This Order does not allow for an increased discharge flow rate or a reduced level of treatment relative to the previous order. This Order establishes effluent limitations for dichlorobromomethane as stringent as those in the previous order. The dichlorobromomethane mixing zone is somewhat larger than the one the previous order granted, but it is as small as practicable and remains smaller than the hypothetical dichlorobromomethane mixing zone assessed in Fact Sheet section 4.3.4.2. The Regional Water Board has no evidence to suggest that the existing water quality will be reduced. Therefore, no further antidegradation analysis required.

- 4.4.3. **Stringency of Requirements for Individual Pollutants.** This Order contains both technology-based and water quality-based effluent limitations for individual pollutants. The technology-based requirements implement minimum, applicable federal technology-based requirements. In addition, this Order contains more stringent effluent limitations as necessary to meet water quality standards. Collectively, this Order's restrictions on individual pollutants are no more stringent than required to implement CWA requirements.

This Order's WQBELs have been derived to implement water quality objectives that protect beneficial uses. The beneficial uses and water quality objectives have been approved pursuant to federal law and are the applicable federal water quality standards. To the extent that WQBELs were derived from the CTR, the CTR is the applicable standard pursuant to 40 C.F.R. section 131.38. The procedures for calculating these WQBELs are based on the CTR, as implemented in accordance with the SIP, which U.S. EPA approved on May 18, 2000. U.S. EPA approved most Basin Plan beneficial uses and water quality objectives prior to May 30, 2000. Beneficial uses and water quality objectives submitted to U.S. EPA prior to May 30, 2000, but not approved by U.S. EPA before that date, are nonetheless "applicable water quality standards for purposes of the CWA" pursuant to 40 C.F.R. section 131.21(c)(1). U.S. EPA approved the remaining beneficial uses and water quality objectives, so they are also applicable water quality standards pursuant to 40 C.F.R. section 131.21(c)(2).

## 5. RATIONALE FOR RECEIVING WATER LIMITATIONS

The receiving water limitations in sections 5.1 and 5.2 of the Order are based on Basin Plan narrative and numeric water quality objectives. The receiving water limitation in section 5.3 of the Order requires compliance with federal and State water quality standards in accordance with the CWA and regulations adopted thereunder.

## 6. RATIONALE FOR PROVISIONS

### 6.1. Standard Provisions

Attachment D contains standard provisions that apply to all NPDES permits in accordance with 40 C.F.R. section 122.41 and additional conditions applicable to specific categories of permits in accordance with 40 C.F.R. section 122.42. The Discharger must comply with these provisions. The conditions set forth in 40 C.F.R. sections 122.41(a)(1) and (b) through (n) apply to all state-issued NPDES permits and must be incorporated into permits either expressly or by reference.

In accordance with 40 C.F.R. section 123.25(a)(12), states may omit or modify conditions to impose more stringent requirements. Attachment G contains standard provisions that supplement the provisions in Attachment D. This Order omits the federal conditions that address enforcement authority specified in 40 C.F.R. sections 122.41(j)(5) and (k)(2) because the State's enforcement authority under the Water Code is more stringent. In lieu of these conditions, this Order incorporates Water Code section 13387(e) by reference.

### 6.2. Monitoring and Reporting Provisions

CWA section 308 and 40 C.F.R. sections 122.41(h), 122.41(j)-(l), 122.44(i), and 122.48 require that NPDES permits specify monitoring and reporting requirements. Water Code section 13383 also authorizes the Regional Water Board to establish monitoring, inspection, entry, reporting, and recordkeeping requirements. The MRP establishes monitoring, reporting, and recordkeeping requirements that implement federal and State requirements. For more information, see Fact Sheet section 7.

### 6.3. Special Provisions

#### 6.3.1. Reopener Provisions

These provisions are based on 40 C.F.R. sections 122.62 and 122.63 and allow modification of this Order and its effluent limitations as necessary in response to updated water quality objectives, regulations, or other new and relevant information that may become available in the future, and other circumstances as allowed by law.

#### 6.3.2. Best Management Practices (BMPs) Plan

Provision 6.3.2 is required to justify an exception to Basin Plan Discharge Prohibition 1 (see Fact Sheet section 4.1.2). Basin Plan Discharge Prohibition 1 is intended to protect shallow waters from the effects of abnormal discharges caused by temporary upsets and malfunctions. The Discharger submitted its BMPs Plan, *NPDES Best Management Practices Plan for EBMUD Lafayette, Orinda, and Walnut Creek Treatment Plants* (December 2020), with its

application for permit reissuance. This BMPs Plan will prevent any abnormal discharges caused by temporary upsets or malfunctions.

## 7. RATIONALE FOR MONITORING AND REPORTING REQUIREMENTS

The following provides the rationale for the monitoring and reporting requirements in the MRP.

### 7.1. Monitoring Requirements Rationale

- 7.1.1. **Effluent Monitoring.** Effluent flow monitoring is necessary to understand Facility operations. Monitoring for other parameters is necessary to evaluate compliance with this Order's effluent limitations and to conduct future reasonable potential analyses.
- 7.1.3. **Toxicity Monitoring.** Acute toxicity testing is necessary to evaluate compliance with the acute toxicity effluent limitations.
- 7.1.4. **Receiving Water Monitoring.** Receiving water monitoring is necessary to characterize the receiving water and to evaluate reasonable potential for the next permit reissuance.

## 8. PUBLIC PARTICIPATION

The Regional Water Board considered the issuance of WDRs that will serve as an NPDES permit for the Facility. As a step in the WDR adoption process, Regional Water Board staff developed tentative WDRs and encouraged public participation in the WDR adoption process.

- 8.1. **Notification of Interested Parties.** The Regional Water Board notified the Discharger and interested agencies and persons of its intent to prescribe WDRs for the discharge, and provided an opportunity to submit written comments and recommendations. The public had access to the agenda and any changes in dates and locations through the [Regional Water Board's website](https://waterboards.ca.gov/sanfranciscobay) (waterboards.ca.gov/sanfranciscobay).
- 8.2. **Written Comments.** Interested persons were invited to submit written comments concerning the tentative WDRs as explained through the notification process. Comments were to be submitted either in person or by mail to the Executive Office at the Regional Water Board at 1515 Clay Street, Suite 1400, Oakland, California 94612, to the attention of Marcos De la Cruz.

Written comments were due at the Regional Water Board office by 5:00 p.m. on **June 7, 2021.**

- 8.3. **Public Hearing.** The Regional Water Board held a public hearing on the tentative Order during its meeting at the following date and time:

Date: July 14, 2021  
Time: 9:00 a.m.

Contact: Marcos De la Cruz, (510) 622-2365,  
[marcos.delacruz@waterboards.ca.gov](mailto:marcos.delacruz@waterboards.ca.gov).

Interested persons were invited to attend. At the public hearing, the Regional Water Board heard testimony pertinent to the discharge and Order.

Dates and venue can change. The [Regional Water Board's website](http://waterboards.ca.gov/sanfranciscobay) ([waterboards.ca.gov/sanfranciscobay](http://waterboards.ca.gov/sanfranciscobay)) is where one can access the current agenda for changes.

- 8.4. Reconsideration of Waste Discharge Requirements.** Any person aggrieved by this Regional Water Board action may petition the State Water Board to review the action in accordance with Water Code section 13320 and California Code of Regulations, title 23, sections 2050. The State Water Board must receive the petition at the following address within 30 calendar days of the date of Regional Water Board action:

State Water Resources Control Board  
Office of Chief Counsel  
P.O. Box 100, 1001 I Street  
Sacramento, CA 95812-0100

A petition may also be filed by email at [waterqualitypetitions@waterboards.ca.gov](mailto:waterqualitypetitions@waterboards.ca.gov).

For instructions on how to file a water quality petition for review, see the [Water Board's petition instructions](http://waterboards.ca.gov/public_notices/petitions/water_quality/wqpetition_instr.shtml) ([waterboards.ca.gov/public\\_notices/petitions/water\\_quality/wqpetition\\_instr.shtml](http://waterboards.ca.gov/public_notices/petitions/water_quality/wqpetition_instr.shtml)).

- 8.5. Information and Copying.** The Report of Waste Discharge, related supporting documents, and comments received are on file and may be inspected at the Regional Water Board address above at any time online or by contacting the Regional Water Board's custodian of records. Document copying may be arranged by calling (510) 622-2300.
- 8.6. Register of Interested Persons.** Any person interested in being placed on the mailing list for information regarding the WDRs and NPDES permit should contact the Regional Water Board, reference the Facility, and provide a name, address, and phone number.
- 8.7. Additional Information.** Requests for additional information or questions regarding this Order should be directed to Marcos De la Cruz, (510) 622-2365, [marcos.delacruz@waterboards.ca.gov](mailto:marcos.delacruz@waterboards.ca.gov).

**ATTACHMENT G – REGIONAL STANDARD PROVISIONS,  
AND MONITORING AND REPORTING REQUIREMENTS  
(SUPPLEMENT TO ATTACHMENT D)**

**Contents**

<b>1. STANDARD PROVISIONS – PERMIT COMPLIANCE .....</b>	<b>G-2</b>
1.1. DUTY TO COMPLY – NOT SUPPLEMENTED .....	G-2
1.2. NEED TO HALT OR REDUCE ACTIVITY NOT A DEFENSE – NOT SUPPLEMENTED .....	G-2
1.3. DUTY TO MITIGATE – SUPPLEMENT TO ATTACHMENT D, PROVISION 1.3. ....	G-2
1.4. PROPER OPERATION AND MAINTENANCE – SUPPLEMENT TO ATTACHMENT D, PROVISION 1.4.....	G-3
1.5. PROPERTY RIGHTS – NOT SUPPLEMENTED .....	G-4
1.6. INSPECTION AND ENTRY – NOT SUPPLEMENTED .....	G-4
1.7. BYPASS – NOT SUPPLEMENTED .....	G-4
1.8. UPSET – NOT SUPPLEMENTED .....	G-4
1.9. OTHER – ADDITION TO ATTACHMENT D .....	G-4
<b>2. STANDARD PROVISIONS – PERMIT ACTION – NOT SUPPLEMENTED .....</b>	<b>G-4</b>
<b>3. STANDARD PROVISIONS – MONITORING .....</b>	<b>G-4</b>
3.1. SAMPLING AND ANALYSES – SUPPLEMENT TO ATTACHMENT D, PROVISIONS 3.1 AND 3.2 .....	G-4
3.2. STANDARD OBSERVATIONS – ADDITION TO ATTACHMENT D.....	G-7
<b>4. STANDARD PROVISIONS – RECORDS .....</b>	<b>G-8</b>
4.1. RECORDS TO BE MAINTAINED – SUPPLEMENT TO ATTACHMENT D, PROVISION 4.1 .....	G-8
4.2. RECORDS OF MONITORING – SUPPLEMENT TO ATTACHMENT D, PROVISION 4.2 .....	G-8
4.3. CLAIMS OF CONFIDENTIALITY – NOT SUPPLEMENTED .....	G-10
<b>5. STANDARD PROVISIONS – REPORTING .....</b>	<b>G-10</b>
5.1. DUTY TO PROVIDE INFORMATION – NOT SUPPLEMENTED.....	G-10
5.2. SIGNATORY AND CERTIFICATION REQUIREMENTS – NOT SUPPLEMENTED.....	G-10
5.3. MONITORING REPORTS – SUPPLEMENT TO ATTACHMENT D, PROVISION 5.3 .....	G-10
5.4. COMPLIANCE SCHEDULES – NOT SUPPLEMENTED .....	G-13
5.5. TWENTY-FOUR HOUR REPORTING – SUPPLEMENT TO ATTACHMENT D, PROVISION 5.5 .....	G-14
5.6. PLANNED CHANGES – NOT SUPPLEMENTED .....	G-16
5.7. ANTICIPATED NONCOMPLIANCE – NOT SUPPLEMENTED.....	G-16
5.8. OTHER NONCOMPLIANCE – NOT SUPPLEMENTED.....	G-16
5.9. OTHER INFORMATION – NOT SUPPLEMENTED.....	G-16
<b>6. STANDARD PROVISIONS – ENFORCEMENT – NOT SUPPLEMENTED .....</b>	<b>G-16</b>
<b>7. ADDITIONAL PROVISIONS – NOTIFICATION LEVELS – NOT SUPPLEMENTED.....</b>	<b>G-16</b>
<b>8. DEFINITIONS – ADDITION TO ATTACHMENT D.....</b>	<b>G-16</b>

**ATTACHMENT G – REGIONAL STANDARD PROVISIONS,  
AND MONITORING AND REPORTING REQUIREMENTS  
(SUPPLEMENT TO ATTACHMENT D)**

**APPLICABILITY**

This document supplements the requirements of Federal Standard Provisions (Attachment D). For clarity, these provisions are arranged using to the same headings as those used in Attachment D.

**1. STANDARD PROVISIONS – PERMIT COMPLIANCE**

**1.1. Duty to Comply** – Not Supplemented

**1.2. Need to Halt or Reduce Activity Not a Defense** – Not Supplemented

**1.3. Duty to Mitigate** – Supplement to Attachment D, Provision 1.3.

**1.3.1. Contingency Plan.** The Discharger shall maintain a Contingency Plan as prudent in accordance with current facility emergency planning. The Contingency Plan shall describe procedures to ensure that existing facilities remain in, or are rapidly returned to, operation in the event of a process failure or emergency incident, such as employee strike, strike by suppliers of chemicals or maintenance services, power outage, vandalism, earthquake, or fire. The Discharger may combine the Contingency Plan and Spill Prevention Plan (see Provision 1.3.2, below) into one document. In accordance with Regional Water Board Resolution No. 74-10, discharge in violation of the permit where the Discharger has failed to develop and implement a Contingency Plan as described below may be the basis for considering the discharge a willful and negligent violation of the permit pursuant to California Water Code section 13387. The Contingency Plan shall, at a minimum, provide for the following:

- 1.3.1.1. Sufficient personnel for continued facility operation and maintenance during employee strikes or strikes against contractors providing services;
- 1.3.1.2. Maintenance of adequate chemicals or other supplies, and spare parts necessary for continued facility operations;
- 1.3.1.3. Emergency standby power;
- 1.3.1.4. Protection against vandalism;
- 1.3.1.5. Expeditious action to repair failures of, or damage to, equipment, including any sewer lines;

- 1.3.1.6. Reporting of spills and discharges of untreated or inadequately treated wastes, including measures taken to clean up the effects of such discharges; and
- 1.3.1.7. Maintenance, replacement, and surveillance of physical condition of equipment and facilities, including any sewer lines.
- 1.3.2. **Spill Prevention Plan.** The Discharger shall maintain a Spill Prevention Plan to prevent accidental discharges and to minimize the effects of any such discharges. The Spill Prevention Plan shall do the following:
  - 1.3.2.1. Identify the possible sources of accidental discharge, untreated or partially-treated waste bypass, and polluted drainage;
  - 1.3.2.2. State when current facilities and procedures became operational and evaluate their effectiveness; and
  - 1.3.2.3. Predict the effectiveness of any proposed facilities and procedures and provide an implementation schedule with interim and final dates when the proposed facilities and procedures will be constructed, implemented, or operational.
- 1.4. **Proper Operation and Maintenance** – Supplement to Attachment D, Provision 1.4
  - 1.4.1. **Operation and Maintenance Manual.** The Discharger shall maintain an Operation and Maintenance Manual to provide the plant and regulatory personnel with a source of information describing all equipment, recommended operational strategies, process control monitoring, and maintenance activities. To remain a useful and relevant document, the Operation and Maintenance Manual shall be kept updated to reflect significant changes in treatment facility equipment and operational practices. The Operation and Maintenance Manual shall be maintained in usable condition and be available for reference and use by all relevant personnel and Regional Water Board staff.
  - 1.4.2. **Wastewater Facilities Status Report.** The Discharger shall maintain a Wastewater Facilities Status Report and regularly review, revise, or update it, as necessary. This report shall document how the Discharger operates and maintains its wastewater collection, treatment, and disposal facilities to ensure that all facilities are adequately staffed, supervised, financed, operated, maintained, repaired, and upgraded as necessary to provide adequate and reliable transport, treatment, and disposal of all wastewater from both existing and planned future wastewater sources under the Discharger's service responsibilities.
  - 1.4.3. **Proper Supervision and Operation of Publicly-Owned Treatment Works (POTWs).** POTWs shall be supervised and operated by persons possessing

certificates of appropriate grade pursuant to Title 23, section 3680, of the California Code of Regulations.

**1.5. Property Rights** – Not Supplemented

**1.6. Inspection and Entry** – Not Supplemented

**1.7. Bypass** – Not Supplemented

**1.8. Upset** – Not Supplemented

**1.9. Other** – Addition to Attachment D

1.9.1. Neither the treatment nor the discharge of pollutants shall create pollution, contamination, or nuisance as defined by California Water Code section 13050.

1.9.2. Collection, treatment, storage, and disposal systems shall be operated in a manner that precludes public contact with wastewater. If public contact with wastewater could reasonably occur on public property, warning signs shall be posted.

1.9.3. If the Discharger submits a timely and complete Report of Waste Discharge for permit reissuance, this permit shall continue in force and effect until the permit is reissued or the Regional Water Board rescinds the permit.

**2. STANDARD PROVISIONS – PERMIT ACTION – NOT SUPPLEMENTED**

**3. STANDARD PROVISIONS – MONITORING**

**3.1. Sampling and Analyses** – Supplement to Attachment D, Provisions 3.1 and 3.2

3.1.1. **Certified Laboratories.** Water and waste analyses shall be performed by a laboratory certified for these analyses in accordance with California Water Code section 13176.

3.1.2. **Minimum Levels.** For the 126 priority pollutants, the Discharger should use the analytical methods listed in Table B unless the Monitoring and Reporting Program (MRP, Attachment E) requires a particular method or minimum level (ML). All monitoring instruments and equipment shall be properly calibrated and maintained to ensure accuracy of measurements.

3.1.3. **Monitoring Frequency.** The MRP specifies the minimum sampling and analysis schedule.

**3.1.3.1. Sample Collection Timing**

3.1.3.1.1. The Discharger shall collect influent samples on varying days selected at random and shall not include any plant recirculation or other sidestream wastes, unless otherwise stipulated in the MRP. The Executive Officer



may approve an alternative influent sampling plan if it is representative of plant influent and complies with all other permit requirements.

- 3.1.3.1.2. The Discharger shall collect effluent samples on days coincident with influent sampling, unless otherwise stipulated by the MRP. If influent sampling is not required, the Discharger shall collect effluent samples on varying days selected at random, unless otherwise stipulated in the MRP. The Executive Officer may approve an alternative effluent sampling plan if it is representative of plant discharge and in compliance with all other permit requirements.
- 3.1.3.1.3. The Discharger shall collect effluent grab samples during periods of daytime maximum peak flows (or peak flows through secondary treatment units for facilities that recycle effluent).
- 3.1.3.1.4. Effluent sampling for conventional pollutants shall occur on at least one day of any multiple-day bioassay the MRP requires. During the course of the bioassay, on at least one day, the Discharger shall collect and retain samples of the discharge. In the event that a bioassay result does not comply with effluent limitations, the Discharger shall analyze the retained samples for pollutants that could be toxic to aquatic life and for which it has effluent limitations.
  - 3.1.3.1.4.1. The Discharger shall perform bioassays on final effluent samples; when chlorine is used for disinfection, bioassays shall be performed on effluent after chlorination and dechlorination; and
  - 3.1.3.1.4.2. The Discharger shall analyze for total ammonia nitrogen and calculate the amount of un-ionized ammonia whenever test results fail to meet effluent limitations.
- 3.1.3.2. **Conditions Triggering Accelerated Monitoring**
  - 3.1.3.2.1. **Average Monthly Effluent Limitation Exceedance.** If the results from two consecutive samples of a constituent monitored in a particular month exceed the average monthly effluent limitation for any parameter (or if the required sampling frequency is once per month or less and the monthly sample exceeds the average monthly effluent limitation), the Discharger shall, within 24 hours after the results are received, increase its sampling frequency to daily until the results from the additional sampling show that the parameter complies with the average monthly effluent limitation.
  - 3.1.3.2.2. **Maximum Daily Effluent Limitation Exceedance.** If a sample result exceeds a maximum daily effluent limitation, the Discharger shall, within 24 hours after the result is received, increase its sampling frequency to daily until the results from two samples collected on consecutive days show compliance with the maximum daily effluent limitation.

- 3.1.3.2.3. **Acute Toxicity.** If final or intermediate results of an acute bioassay indicate a violation or threatened violation (e.g., the percentage of surviving test organisms of any single acute bioassay is less than 70 percent), the Discharger shall initiate a new test as soon as practical or as described in applicable State Water Board plan provisions that become effective after adoption of these Regional Standard Provisions. The Discharger shall investigate the cause of the mortalities and report its findings in the next self-monitoring report.
- 3.1.3.2.4. **Chlorine.** The Discharger shall calibrate chlorine residual analyzers against grab samples as frequently as necessary to maintain accurate control and reliable operation. If an effluent violation is detected, the Discharger shall collect grab samples at least every 30 minutes until compliance with the limitation is achieved, unless the Discharger monitors chlorine residual continuously. In such cases, the Discharger shall continue to conduct continuous monitoring.
- 3.1.3.2.5. **Bypass.** Except as indicated below, if a Discharger bypasses any portion of its treatment facility, it shall monitor flows and collect samples at affected discharge points and analyze samples for all constituents with effluent limitations on a daily basis for the duration of the bypass. The Discharger need not accelerate chronic toxicity monitoring. The Discharger also need not collect and analyze samples for mercury, dioxin-TEQ, and PCBs after the first day of the bypass. The Discharger may satisfy the accelerated acute toxicity monitoring requirement by conducting a flow-through test or static renewal test that captures the duration of the bypass (regardless of the method specified in the MRP). If bypassing disinfection units only, the Discharger shall only monitor bacteria indicators daily.
- 3.1.3.2.5.1. **Bypass for Essential Maintenance.** If a Discharger bypasses a treatment unit for essential maintenance pursuant to Attachment D section 1.7.2, the Executive Officer may reduce the accelerated monitoring requirements above if the Discharger (i) monitors effluent at affected discharge points on the first day of the bypass for all constituents with effluent limitations, except chronic toxicity; and (ii) identifies and implements measures to ensure that the bypass will continue to comply with effluent limitations.
- 3.1.3.2.5.2. **Approved Wet Weather Bypasses.** If a Discharger bypasses a treatment unit or permitted outfall during wet weather with Executive Officer approval pursuant to Attachment D section 1.7.4, the Discharger shall monitor flows and collect and retain samples for affected discharge points on a daily basis for the duration of the bypass. The Discharger shall analyze daily for TSS using 24-hour composites (or more frequent increments) and for bacteria indicators with effluent limitations using grab samples. If TSS exceeds 45 mg/L in any

composite sample, the Discharger shall also analyze daily the retained samples for all other constituents with effluent limitations, except oil and grease, mercury, PCBs, dioxin-TEQ, and acute and chronic toxicity. Additionally, at least once each year, the Discharger shall analyze the retained samples for one approved bypass for all other constituents with effluent limitations, except oil and grease, mercury, PCBs, dioxin-TEQ, and acute and chronic toxicity. This monitoring shall be in addition to the minimum monitoring specified in the MRP.

### 3.2. Standard Observations – Addition to Attachment D

- 3.2.1. **Receiving Water Observations.** The following requirements only apply when the MRP requires standard observations of receiving waters. Standard observations shall include the following:
- 3.2.1.1. **Floating and Suspended Materials (e.g., oil, grease, algae, and other macroscopic particulate matter)** — presence or absence, source, and size of affected area.
  - 3.2.1.2. **Discoloration and Turbidity** — color, source, and size of affected area.
  - 3.2.1.3. **Odor** — presence or absence, characterization, source, and distance of travel.
  - 3.2.1.4. **Beneficial Water Use** — estimated number of water-associated waterfowl or wildlife, fisherpeople, and other recreational activities.
  - 3.2.1.5. **Hydrographic Condition** — time and height of high and low tides (corrected to nearest National Oceanic and Atmospheric Administration location for the sampling date and time).
  - 3.2.1.6. **Weather Conditions** — wind direction, air temperature, and total precipitation during five days prior to observation.
- 3.2.2. **Wastewater Effluent Observations.** The following requirements only apply when the MRP requires standard observations of wastewater effluent. Standard observations shall include the following:
- 3.2.2.1. **Floating and Suspended Material of Wastewater Origin** (e.g., oil, grease, algae, and other macroscopic particulate matter) — presence or absence.
  - 3.2.2.2. **Odor** — presence or absence, characterization, source, distance of travel, and wind direction.
- 3.2.3. **Beach and Shoreline Observations.** The following requirements only apply when the MRP requires standard observations of beaches or shorelines. Standard observations shall include the following:

- 3.2.3.1. **Material of Wastewater Origin** — presence or absence, description of material, estimated size of affected area, and source.
- 3.2.3.2. **Beneficial Use** — estimate of number of people participating in recreational water contact, non-water contact, and fishing activities.
- 3.2.4. **Waste Treatment and/or Disposal Facility Periphery Observations.**  
The following requirements only apply when the MRP requires standard observations of the periphery of waste treatment or disposal facilities. Standard observations shall include the following:
  - 3.2.4.1. **Odor** — presence or absence, characterization, source, and distance of travel.
  - 3.2.4.2. **Weather Conditions** — wind direction and estimated velocity.

#### 4. STANDARD PROVISIONS – RECORDS

##### 4.1. Records to be Maintained – Supplement to Attachment D, Provision 4.1

The Discharger shall maintain records in a manner and at a location (e.g., the wastewater treatment plant or the Discharger's offices) such that the records are accessible to Regional Water Board staff. The minimum retention period specified in Attachment D, Provision IV, shall be extended during the course of any unresolved litigation regarding permit-related discharges, or when requested by Regional Water Board or U.S. EPA, Region IX, staff.

A copy of the permit shall be maintained at the discharge facility and be available at all times to operating personnel.

##### 4.2. Records of Monitoring – Supplement to Attachment D, Provision 4.2

Monitoring records shall include the following:

- 4.2.1. **Analytical Information.** Records shall include analytical method detection limits, minimum levels, reporting levels, and related quantification parameters.
- 4.2.2. **Disinfection Process.** For the disinfection process, records shall include the following:
  - 4.2.2.1. For bacteriological analyses:
    - 4.2.2.1.1. Wastewater flow rate at the time of sample collection; and
    - 4.2.2.1.2. Required statistical parameters for cumulative bacterial values (e.g., moving median or geometric mean for the number of samples or sampling period identified in the MRP).

4.2.2.2. For the chlorination process (when chlorine is used for disinfection), at least daily average values for the following:

4.2.2.2.1. Chlorine residual of treated wastewater as it enters the chlorine contact basin (mg/L);

4.2.2.2.2. Chlorine dosage (kg/day); and

4.2.2.2.3. Dechlorination chemical dosage (kg/day).

4.2.3. **Wastewater Treatment Process Solids.** For each treatment unit process that involves solids removal from the wastewater stream, records shall include the following:

4.2.3.1. Total volume or mass of solids removed from each collection unit (e.g., grit, skimmings, undigested biosolids, or combination) for each calendar month or other time period as appropriate, but not to exceed annually; and

4.2.3.2. Final disposition of such solids (e.g., landfill, other subsequent treatment unit).

4.2.4. **Treatment Process Bypasses.** For all treatment process bypasses, including wet weather blending, records shall include the following:

4.2.4.1. Chronological log of treatment process bypasses;

4.2.4.2. Identification of treatment processes bypassed;

4.2.4.3. Beginning and ending dates and times of bypasses;

4.2.4.4. Bypass durations;

4.2.4.5. Estimated bypass volumes; and

4.2.4.6. Description of, or reference to other reports describing, the bypasses, their cause, the corrective actions taken (except for wet weather blending explicitly approved within the permit and in compliance with any related permit conditions), and any additional monitoring conducted.

4.2.5. **Treatment Plant Overflows.** The Discharger shall retain a chronological log of overflows at the treatment plant, including the headworks and all units and appurtenances downstream, and records supporting the information provided in accordance with Provision 5.5.2, below.

#### 4.3. Claims of Confidentiality – Not Supplemented

### 5. STANDARD PROVISIONS – REPORTING

#### 5.1. Duty to Provide Information – Not Supplemented

#### 5.2. Signatory and Certification Requirements – Not Supplemented

#### 5.3. Monitoring Reports – Supplement to Attachment D, Provision 5.3

5.3.1. **Self-Monitoring Reports.** For each reporting period established in the MRP, the Discharger shall submit a self-monitoring report to the Regional Water Board in accordance with the requirements listed in the MRP and below:

5.3.1.1. **Transmittal Letter.** Each self-monitoring report shall be submitted with a transmittal letter that includes the following:

- 5.3.1.1.1. Identification of all violations of effluent limitations or other waste discharge requirements found during the reporting period;
- 5.3.1.1.2. Details regarding the violations, such as parameters, magnitude, test results, frequency, and dates;
- 5.3.1.1.3. Causes of the violations;
- 5.3.1.1.4. Corrective actions taken or planned to resolve violations and prevent recurrences, and dates or time schedules for implementation (the Discharger may refer to previously submitted reports that address the corrective actions);
- 5.3.1.1.5. Explanation for any data invalidation. Data should not be submitted in a self-monitoring report if it does not meet quality assurance/quality control standards. However, if the Discharger wishes to invalidate a measurement after submitting it in a self-monitoring report, the Discharger shall identify the measurement suspected to be invalid and state the Discharger's intent to submit, within 60 days, a formal request to invalidate the measurement. The formal request shall include the original measurement in question, the reason for invalidating the measurement, all relevant documentation that supports invalidation (e.g., laboratory sheet, log entry, test results), and a discussion of the corrective actions taken or planned (with a time schedule for completion) to prevent recurrence of the sampling or measurement problem;
- 5.3.1.1.6. Description of blending, if any. If the Discharger blends, it shall describe the duration of blending events and certify whether the blending complied with all conditions for blending;

- 5.3.1.1.7. Description of other bypasses, if any. If the Discharger bypasses any treatment units (other than blending), it shall describe the duration of the bypasses and effluent quality during those times; and
- 5.3.1.1.8. Signature. The transmittal letter shall be signed in accordance with Attachment D, Provision 5.2.
- 5.3.1.2. **Compliance Evaluation Summary.** Each self-monitoring report shall include a compliance evaluation summary that addresses each parameter for which the permit specifies effluent limitations, the number of samples taken during the monitoring period, and the number of samples that exceed the effluent limitations.
- 5.3.1.3. **More Frequent Monitoring.** If the Discharger monitors any pollutant more frequently than required by the MRP, the Discharger shall include the results of such monitoring in the calculation and reporting of the data submitted in the self-monitoring report.
- 5.3.1.4. **Analysis Results**
- 5.3.1.4.1. **Tabulation.** Each self-monitoring report shall include tabulations of all required analyses and observations, including parameters, dates, times, sample stations, types of samples, test results, method detection limits, method minimum levels, and method reporting levels (if applicable), signed by the laboratory director or other responsible official.
- 5.3.1.4.2. **Multiple Samples.** Unless the MRP specifies otherwise, when determining compliance with effluent limitations (other than instantaneous effluent limitations) and more than one sample result is available, the Discharger shall compute the arithmetic mean. If the data set contains one or more results that are “Detected, but Not Quantified (DNQ) or “Not Detected” (ND), the Discharger shall instead compute the median in accordance with the following procedure:
- 5.3.1.4.2.1. The data set shall be ranked from low to high, reported ND determinations lowest, DNQ determinations next, followed by quantified values (if any). The order of the individual ND or DNQ determinations is unimportant.
- 5.3.1.4.2.2. The median of the data set shall be determined. If the data set has an odd number of data points, the median is the middle value. If the data set has an even number of data points, the median is the average of the two values around the middle, unless one or both of these values is ND or DNQ, in which case the median shall be the lower of the two results (where DNQ is lower than a quantified value and ND is lower than DNQ).

5.3.1.4.3. **Duplicate Samples.** The Discharger shall report the average of duplicate sample analyses when reporting for a single sample result (or the median if one or more of the duplicates is DNQ or ND [see Provision 5.3.1.4.2, above]). For bacteria indicators, the Discharger shall report the geometric mean of the duplicate analyses.

5.3.1.4.4. **Dioxin-TEQ.** The Discharger shall report for each dioxin and furan congener the analytical results of effluent monitoring, including the reporting level, the method detection limit, and the measured concentration. The Discharger shall report all measured values of individual congeners, including data qualifiers. When calculating dioxin-TEQ, the Discharger shall set congener concentrations below the minimum levels (MLs) to zero. The Discharger shall calculate and report dioxin-TEQ using the following formula, where the MLs, toxicity equivalency factors (TEFs), and bioaccumulation equivalency factors (BEFs) are as provided in Table A:

$$\text{Dioxin-TEQ} = \sum (C_x \times \text{TEF}_x \times \text{BEF}_x)$$

where:  $C_x$  = measured or estimated concentration of congener  $x$   
 $\text{TEF}_x$  = toxicity equivalency factor for congener  $x$   
 $\text{BEF}_x$  = bioaccumulation equivalency factor for congener  $x$

**Table A**  
**Minimum Levels, Toxicity Equivalency Factors,**  
**and Bioaccumulation Equivalency Factors**

Dioxin or Furan Congener	Minimum Level (pg/L)	2005 Toxicity Equivalency Factor (TEF)	Bioaccumulation Equivalency Factor (BEF)
2,3,7,8-TCDD	10	1.0	1.0
1,2,3,7,8-PeCDD	50	1.0	0.9
1,2,3,4,7,8-HxCDD	50	0.1	0.3
1,2,3,6,7,8-HxCDD	50	0.1	0.1
1,2,3,7,8,9-HxCDD	50	0.1	0.1
1,2,3,4,6,7,8-HpCDD	50	0.01	0.05
OCDD	100	0.0003	0.01
2,3,7,8-TCDF	10	0.1	0.8
1,2,3,7,8-PeCDF	50	0.03	0.2
2,3,4,7,8-PeCDF	50	0.3	1.6
1,2,3,4,7,8-HxCDF	50	0.1	0.08
1,2,3,6,7,8-HxCDF	50	0.1	0.2
1,2,3,7,8,9-HxCDF	50	0.1	0.6
2,3,4,6,7,8-HxCDF	50	0.1	0.7
1,2,3,4,6,7,8-HpCDF	50	0.01	0.01
1,2,3,4,7,8,9-HpCDF	50	0.01	0.4
OCDF	100	0.0003	0.02



- 5.3.1.5. **Results Not Yet Available.** The Discharger shall make all reasonable efforts to obtain analytical data for required parameter sampling in a timely manner. Certain analyses may require additional time to complete analytical processes and report results. In these cases, the Discharger shall describe the circumstances in the self-monitoring report and include the data for these parameters and relevant discussions of any violations in the next self-monitoring report due after the results are available.
- 5.3.1.6. **Annual Self-Monitoring Reports.** By the date specified in the MRP, the Discharger shall submit an annual self-monitoring report covering the previous calendar year. The report shall contain the following:
- 5.3.1.6.1. Comprehensive discussion of treatment plant performance, including documentation of any blending or other bypass events, and compliance with the permit. This discussion shall include any corrective actions taken or planned, such as changes to facility equipment or operation practices that may be needed to achieve compliance, and any other actions taken or planned that are intended to improve the performance and reliability of wastewater collection, treatment, or disposal practices;
  - 5.3.1.6.2. List of approved analyses, including the following:
    - 5.3.1.6.2.1. List of analyses for which the Discharger is certified;
    - 5.3.1.6.2.2. List of analyses performed for the Discharger by a separate certified laboratory (copies of reports signed by the laboratory director of that laboratory need not be submitted but shall be retained onsite); and
    - 5.3.1.6.2.3. List of “waived” analyses, as approved;
  - 5.3.1.6.3. Plan view drawing or map showing the Discharger’s facility, flow routing, and sampling and observation station locations; and
  - 5.3.1.6.4. Results of facility report reviews. The Discharger shall regularly review, revise, and update, as necessary, the Operation and Maintenance Manual, Contingency Plan, Spill Prevention Plan, and Wastewater Facilities Status Report so these documents remain useful and relevant to current practices. At a minimum, reviews shall be conducted annually. The Discharger shall describe or summarize its review and evaluation procedures, recommended or planned actions, and estimated time schedule for implementing these actions. The Discharger shall complete changes to these documents to ensure that they remain up-to-date.

**5.4. Compliance Schedules – Not supplemented**

## **5.5. Twenty-Four Hour Reporting** – Supplement to Attachment D, Provision 5.5

### **5.5.1. Oil or Other Hazardous Material Spills**

5.5.1.1. Within 24 hours of becoming aware of a spill of oil or other hazardous material not contained onsite and completely cleaned up, the Discharger shall report as follows:

5.5.1.1.1. If the spill exceeds reportable quantities for hazardous materials listed in 40 C.F.R. part 302. The Discharger shall call the California Office of Emergency Services (800 852-7550).

5.5.1.1.2. If the spill does not exceed reportable quantities for hazardous materials listed in 40 C.F.R., part 302, the Discharger shall call the Regional Water Board (510-622-2369).

5.5.1.2. The Discharger shall submit a written report to the Regional Water Board within five working days following either of the above telephone notifications unless directed otherwise by Regional Water Board staff. A report submitted electronically is acceptable. The written report shall include the following:

5.5.1.2.1. Date and time of spill, and duration if known;

5.5.1.2.2. Location of spill (street address or description of location);

5.5.1.2.3. Nature of material spilled;

5.5.1.2.4. Quantity of material spilled;

5.5.1.2.5. Receiving water body affected, if any;

5.5.1.2.6. Cause of spill;

5.5.1.2.7. Estimated size of affected area;

5.5.1.2.8. Observed impacts to receiving waters (e.g., oil sheen, fish kill, water discoloration);

5.5.1.2.9. Corrective actions taken to contain, minimize, or clean up the spill;

5.5.1.2.10. Future corrective actions planned to prevent recurrence, and implementation schedule; and

5.5.1.2.11. Persons or agencies notified.

## 5.5.2. **Unauthorized Municipal Wastewater Treatment Plant Discharges**<sup>1</sup>

5.5.2.1. **Two-Hour Notification.** For any unauthorized discharge that enters a drainage channel or surface water, the Discharger shall, as soon as possible, but not later than two hours after becoming aware of the discharge, notify the California Office of Emergency Services (800-852-7550) and the local health officer or director of environmental health with jurisdiction over the affected water body. Notification shall include the following:

- 5.5.2.1.1. Incident description and cause;
- 5.5.2.1.2. Location of threatened or involved waterways or storm drains;
- 5.5.2.1.3. Date and time that the unauthorized discharge started;
- 5.5.2.1.4. Estimated quantity and duration of the unauthorized discharge (to the extent known), and estimated amount recovered;
- 5.5.2.1.5. Level of treatment prior to discharge (e.g., raw wastewater, primary-treated wastewater, or undisinfected secondary-treated wastewater); and
- 5.5.2.1.6. Identity of person reporting the unauthorized discharge.

5.5.2.2. **Five-Day Written Report.** Within five business days following the two-hour notification, the Discharger shall submit a written report that includes, in addition to the information listed in Provision 5.5.2.1, above, the following:

- 5.5.2.2.1. Methods used to delineate the geographical extent of the unauthorized discharge within receiving waters;
- 5.5.2.2.2. Efforts implemented to minimize public exposure to the unauthorized discharge;
- 5.5.2.2.3. Visual observations of the impacts (if any) noted in the receiving waters (e.g., fish kill, discoloration of receiving water) and extent of sampling if conducted;
- 5.5.2.2.4. Corrective measures taken to minimize the impact of the unauthorized discharge;

---

<sup>1</sup> California Code of Regulations, Title 23, section 2250(b), defines an unauthorized discharge to be a discharge, not regulated by waste discharge requirements, of treated, partially-treated, or untreated wastewater resulting from the intentional or unintentional diversion of wastewater from a collection, treatment, or disposal system.

- 5.5.2.2.5. Measures to be taken to minimize the potential for a similar unauthorized discharge in the future;
- 5.5.2.2.6. Summary of Spill Prevention Plan or Operation and Maintenance Manual modifications to be made, if necessary, to minimize the potential for future unauthorized discharges; and
- 5.5.2.2.7. Quantity and duration of the unauthorized discharge, and the amount recovered.

**5.6. Planned Changes** – Not supplemented

**5.7. Anticipated Noncompliance** – Not supplemented

**5.8. Other Noncompliance** – Not supplemented

**5.9. Other Information** – Not supplemented

**6. STANDARD PROVISIONS – ENFORCEMENT – NOT SUPPLEMENTED**

**7. ADDITIONAL PROVISIONS – NOTIFICATION LEVELS – NOT SUPPLEMENTED**

**8. DEFINITIONS – ADDITION TO ATTACHMENT D**

More definitions can be found in Attachment A of this NPDES Permit.

**8.1. Arithmetic Calculations**

- 8.1.1. **Geometric Mean.** The antilog of the log mean or the back-transformed mean of the logarithmically transformed variables, which is equivalent to the multiplication of the antilogarithms. The geometric mean can be calculated with either of the following equations:

$$\text{Geometric Mean} = \text{Anti log} (1/N \sum \text{Log } C_i)$$

or

$$\text{Geometric Mean} = (C_1 \times C_2 \times \dots \times C_N)^{1/N}$$

Where “N” is the number of data points for the period analyzed and “C” is the concentration for each of the “N” data points.

- 8.1.2. **Mass Emission Rate.** The rate of discharge expressed in mass. The mass emission rate is obtained from the following calculation for any calendar day:

$$\text{Mass emission rate (lb/day)} = \frac{8.345}{N} \sum_{i=1}^N Q_i C_i$$

$$\text{Mass emission rate (kg/day)} = \frac{3.785}{N} \sum_{i=1}^N Q_i C_i$$

In which “N” is the number of samples analyzed in any calendar day and “Q<sub>i</sub>” and “C<sub>i</sub>” are the flow rate (MGD) and the constituent concentration (mg/L) associated with each of the “N” grab samples that may be taken in any calendar day. If a composite sample is taken, “C<sub>i</sub>” is the concentration measured in the composite sample and “Q<sub>i</sub>” is the average flow rate occurring during the period over which the samples are composited. The daily concentration of a constituent measured over any calendar day shall be determined from the flow weighted average of the same constituent in the combined waste streams as follows:

$$C_d = \text{Average daily concentration} = \frac{1}{Q_t} \sum_{i=1}^N Q_i C_i$$

In which “N” is the number of component waste streams and “Q” and “C” are the flow rate (MGD) and the constituent concentration (mg/L) associated with each of the “N” waste streams. “Q<sub>t</sub>” is the total flow rate of the combined waste streams.

- 8.1.3. **Removal Efficiency.** The ratio of pollutants removed by the treatment facilities to pollutants entering the treatment facilities (expressed as a percentage). The Discharger shall determine removal efficiencies using monthly averages (by calendar month unless otherwise specified) of pollutant concentration of influent and effluent samples collected at about the same time and using the following equation (or its equivalent):

$$\text{Removal Efficiency (\%)} = 100 \times [1 - (\text{Effluent Concentration} / \text{Influent Concentration})]$$

- 8.2. **Blending** – the practice of bypassing biological treatment units and recombining the bypass wastewater with biologically-treated wastewater.
- 8.3. **Composite Sample** – a sample composed of individual grab samples collected manually or by an automatic sampling device on the basis of time or flow as specified in the MRP. For flow-based composites, the proportion of each grab sample included in the composite sample shall be within plus or minus five percent (+/-5%) of the representative flow of the waste stream being measured at the time of grab sample collection. Alternatively, equal volume grab samples may be individually analyzed with the flow-weighted average calculated by averaging flow-weighted ratios of each grab sample analytical result. Grab samples comprising time-based composite samples shall be collected at intervals not greater than those specified in the MRP. The quantity of each grab sample comprising a time-based composite sample shall be a set of flow proportional volumes as specified in

the MRP. If a particular time-based or flow-based composite sampling protocol is not specified in the MRP, the Discharger shall determine and implement the most representative protocol.

- 8.4. Duplicate Sample** – a second sample taken from the same source and at the same time as an initial sample (such samples are typically analyzed identically to measure analytical variability).
- 8.5. Grab Sample** – an individual sample collected during a short period not exceeding 15 minutes. Grab samples represent only the condition that exists at the time the sample is collected.
- 8.6. Overflow** – the intentional or unintentional spilling or forcing out of untreated or partially-treated waste from a transport system (e.g., through manholes, at pump stations, or at collection points) upstream of the treatment plant headworks or from any part of a treatment plant.
- 8.7. Priority Pollutants** – those constituents referred to in 40 C.F.R. part 122 as promulgated in the Federal Register, Vol. 65, No. 97, Thursday, May 18, 2000, also known as the California Toxics Rule.
- 8.8. Untreated waste** – raw wastewater.

**Table B**  
**List of Monitoring Parameters, Analytical Methods, and Minimum Levels (µg/L)<sup>[1]</sup>**

CTR No.	Pollutant / Parameter	Analytical Method <sup>[2]</sup>	GC	GC MS	LC	Color	FAA	GFAA	ICP	ICP MS	SPGF AA	HYD RIDE	CVAA	DCP
1	Antimony	204.2	-	-	-	-	10	5	50	0.5	5	0.5	-	1000
2	Arsenic	206.3	-	-	-	20	-	2	10	2	2	1	-	1000
3	Beryllium	-	-	-	-	-	20	0.5	2	0.5	1	-	-	1000
4	Cadmium	200 or 213	-	-	-	-	10	0.5	10	0.25	0.5	-	-	1000
5a	Chromium (III)	SM 3500	-	-	-	-	-	-	-	-	-	-	-	-
5b	Chromium (VI)	SM 3500	-	-	-	10	5	-	-	-	-	-	-	1000
	Chromium (total) <sup>[3]</sup>	SM 3500	-	-	-	-	50	2	10	0.5	1	-	-	1000
6	Copper	200.9	-	-	-	-	25	5	10	0.5	2	-	-	1000
7	Lead	200.9	-	-	-	-	20	5	5	0.5	2	-	-	10,000
8	Mercury	1631 <sup>[4]</sup>	-	-	-	-	-	-	-	-	-	-	-	-
9	Nickel	249.2	-	-	-	-	50	5	20	1	5	-	-	1000
10	Selenium	200.8 or SM 3114B or C	-	-	-	-	-	5	10	2	5	1	-	1000
11	Silver	272.2	-	-	-	-	10	1	10	0.25	2	-	-	1000
12	Thallium	279.2	-	-	-	-	10	2	10	1	5	-	-	1000
13	Zinc	200 or 289	-	-	-	-	20	-	20	1	10	-	-	-
14	Cyanide	SM 4500 CN- C or I	-	-	-	5	-	-	-	-	-	-	-	-
15	Asbestos (only required for dischargers to MUN waters) <sup>[5]</sup>	0100.2 <sup>[6]</sup>	-	-	-	-	-	-	-	-	-	-	-	-
16	2,3,7,8-TCDD and 17 congeners (Dioxin)	1613	-	-	-	-	-	-	-	-	-	-	-	-
17	Acrolein	603	2.0	5	-	-	-	-	-	-	-	-	-	-
18	Acrylonitrile	603	2.0	2	-	-	-	-	-	-	-	-	-	-
19	Benzene	602	0.5	2	-	-	-	-	-	-	-	-	-	-
33	Ethylbenzene	602	0.5	2	-	-	-	-	-	-	-	-	-	-
39	Toluene	602	0.5	2	-	-	-	-	-	-	-	-	-	-
20	Bromoform	601	0.5	2	-	-	-	-	-	-	-	-	-	-
21	Carbon Tetrachloride	601	0.5	2	-	-	-	-	-	-	-	-	-	-

CTR No.	Pollutant / Parameter	Analytical Method <sup>[2]</sup>	GC	GC MS	LC	Color	FAA	GFAA	ICP	ICP MS	SPGF AA	HYD RIDE	CVAA	DCP
22	Chlorobenzene	601	0.5	2	-	-	-	-	-	-	-	-	-	-
23	Chlorodibromomethane	601	0.5	2	-	-	-	-	-	-	-	-	-	-
24	Chloroethane	601	0.5	2	-	-	-	-	-	-	-	-	-	-
25	2-Chloroethylvinyl Ether	601	1	1	-	-	-	-	-	-	-	-	-	-
26	Chloroform	601	0.5	2	-	-	-	-	-	-	-	-	-	-
75	1,2-Dichlorobenzene	601	0.5	2	-	-	-	-	-	-	-	-	-	-
76	1,3-Dichlorobenzene	601	0.5	2	-	-	-	-	-	-	-	-	-	-
77	1,4-Dichlorobenzene	601	0.5	2	-	-	-	-	-	-	-	-	-	-
27	Dichlorobromomethane	601	0.5	2	-	-	-	-	-	-	-	-	-	-
28	1,1-Dichloroethane	601	0.5	1	-	-	-	-	-	-	-	-	-	-
29	1,2-Dichloroethane	601	0.5	2	-	-	-	-	-	-	-	-	-	-
30	1,1-Dichloroethylene or 1,1-Dichloroethene	601	0.5	2	-	-	-	-	-	-	-	-	-	-
31	1,2-Dichloropropane	601	0.5	1	-	-	-	-	-	-	-	-	-	-
32	1,3-Dichloropropylene or 1,3-Dichloropropene	601	0.5	2	-	-	-	-	-	-	-	-	-	-
34	Methyl Bromide or Bromomethane	601	1.0	2	-	-	-	-	-	-	-	-	-	-
35	Methyl Chloride or Chloromethane	601	0.5	2	-	-	-	-	-	-	-	-	-	-
36	Methylene Chloride or Dichloromethane	601	0.5	2	-	-	-	-	-	-	-	-	-	-
37	1,1,2,2-Tetrachloroethane	601	0.5	1	-	-	-	-	-	-	-	-	-	-
38	Tetrachloroethylene	601	0.5	2	-	-	-	-	-	-	-	-	-	-
40	1,2-Trans-Dichloroethylene	601	0.5	1	-	-	-	-	-	-	-	-	-	-
41	1,1,1-Trichloroethane	601	0.5	2	-	-	-	-	-	-	-	-	-	-
42	1,1,2-Trichloroethane	601	0.5	2	-	-	-	-	-	-	-	-	-	-
43	Trichloroethene	601	0.5	2	-	-	-	-	-	-	-	-	-	-
44	Vinyl Chloride	601	0.5	2	-	-	-	-	-	-	-	-	-	-
45	2-Chlorophenol	604	2	5	-	-	-	-	-	-	-	-	-	-
46	2,4-Dichlorophenol	604	1	5	-	-	-	-	-	-	-	-	-	-
47	2,4-Dimethylphenol	604	1	2	-	-	-	-	-	-	-	-	-	-



CTR No.	Pollutant / Parameter	Analytical Method <sup>[2]</sup>	GC	GC MS	LC	Color	FAA	GFAA	ICP	ICP MS	SPGF AA	HYD RIDE	CVAA	DCP
48	2-Methyl-4,6-Dinitrophenol or Dinitro-2-methylphenol	604	10	5	-	-	-	-	-	-	-	-	-	-
49	2,4-Dinitrophenol	604	5	5	-	-	-	-	-	-	-	-	-	-
50	2-Nitrophenol	604	-	10	-	-	-	-	-	-	-	-	-	-
51	4-Nitrophenol	604	5	10	-	-	-	-	-	-	-	-	-	-
52	3-Methyl-4-Chlorophenol	604	5	1	-	-	-	-	-	-	-	-	-	-
53	Pentachlorophenol	604	1	5	-	-	-	-	-	-	-	-	-	-
54	Phenol	604	1	1	-	50	-	-	-	-	-	-	-	-
55	2,4,6-Trichlorophenol	604	10	10	-	-	-	-	-	-	-	-	-	-
56	Acenaphthene	610 HPLC	1	1	0.5	-	-	-	-	-	-	-	-	-
57	Acenaphthylene	610 HPLC	-	10	0.2	-	-	-	-	-	-	-	-	-
58	Anthracene	610 HPLC	-	10	2	-	-	-	-	-	-	-	-	-
60	Benzo(a)Anthracene or 1,2 Benzanthracene	610 HPLC	10	5	-	-	-	-	-	-	-	-	-	-
61	Benzo(a)Pyrene	610 HPLC	-	10	2	-	-	-	-	-	-	-	-	-
62	Benzo(b) Fluoranthene or 3,4 Benzofluoranthene	610 HPLC	-	10	10	-	-	-	-	-	-	-	-	-
63	Benzo(ghi)Perylene	610 HPLC	-	5	0.1	-	-	-	-	-	-	-	-	-
64	Benzo(k)Fluoranthene	610 HPLC	-	10	2	-	-	-	-	-	-	-	-	-
74	Dibenzo(a,h)Anthracene	610 HPLC	-	10	0.1	-	-	-	-	-	-	-	-	-
86	Fluoranthene	610 HPLC	10	1	0.05	-	-	-	-	-	-	-	-	-
87	Fluorene	610 HPLC	-	10	0.1	-	-	-	-	-	-	-	-	-
92	Indeno(1,2,3-cd)Pyrene	610 HPLC	-	10	0.05	-	-	-	-	-	-	-	-	-
100	Pyrene	610 HPLC	-	10	0.05	-	-	-	-	-	-	-	-	-
68	Bis(2-Ethylhexyl)Phthalate	606 or 625	10	5	-	-	-	-	-	-	-	-	-	-
70	Butylbenzyl Phthalate	606 or 625	10	10	-	-	-	-	-	-	-	-	-	-
79	Diethyl Phthalate	606 or 625	10	2	-	-	-	-	-	-	-	-	-	-
80	Dimethyl Phthalate	606 or 625	10	2	-	-	-	-	-	-	-	-	-	-
81	Di-n-Butyl Phthalate	606 or 625	-	10	-	-	-	-	-	-	-	-	-	-
84	Di-n-Octyl Phthalate	606 or 625	-	10	-	-	-	-	-	-	-	-	-	-
59	Benzidine	625	-	5	-	-	-	-	-	-	-	-	-	-
65	Bis(2-Chloroethoxy)Methane	625	-	5	-	-	-	-	-	-	-	-	-	-

CTR No.	Pollutant / Parameter	Analytical Method <sup>[2]</sup>	GC	GC MS	LC	Color	FAA	GFAA	ICP	ICP MS	SPGF AA	HYD RIDE	CVAA	DCP
66	Bis(2-Chloroethyl)Ether	625	10	1	-	-	-	-	-	-	-	-	-	-
67	Bis(2-Chloroisopropyl) Ether	625	10	2	-	-	-	-	-	-	-	-	-	-
69	4-Bromophenyl Phenyl Ether	625	10	5	-	-	-	-	-	-	-	-	-	-
71	2-Chloronaphthalene	625	-	10	-	-	-	-	-	-	-	-	-	-
72	4-Chlorophenyl Phenyl Ether	625	-	5	-	-	-	-	-	-	-	-	-	-
73	Chrysene	625	-	10	5	-	-	-	-	-	-	-	-	-
78	3,3'-Dichlorobenzidine	625	-	5	-	-	-	-	-	-	-	-	-	-
82	2,4-Dinitrotoluene	625	10	5	-	-	-	-	-	-	-	-	-	-
83	2,6-Dinitrotoluene	625	-	5	-	-	-	-	-	-	-	-	-	-
85	1,2-Diphenylhydrazine <sup>[7]</sup>	625	-	1	-	-	-	-	-	-	-	-	-	-
88	Hexachlorobenzene	625	5	1	-	-	-	-	-	-	-	-	-	-
89	Hexachlorobutadiene	625	5	1	-	-	-	-	-	-	-	-	-	-
90	Hexachlorocyclopentadiene	625	5	5	-	-	-	-	-	-	-	-	-	-
91	Hexachloroethane	625	5	1	-	-	-	-	-	-	-	-	-	-
93	Isophorone	625	10	1	-	-	-	-	-	-	-	-	-	-
94	Naphthalene	625	10	1	0.2	-	-	-	-	-	-	-	-	-
95	Nitrobenzene	625	10	1	-	-	-	-	-	-	-	-	-	-
96	N-Nitrosodimethylamine	625	10	5	-	-	-	-	-	-	-	-	-	-
97	N-Nitrosodi-n-Propylamine	625	10	5	-	-	-	-	-	-	-	-	-	-
98	N-Nitrosodiphenylamine	625	10	1	-	-	-	-	-	-	-	-	-	-
99	Phenanthrene	625	-	5	0.05	-	-	-	-	-	-	-	-	-
101	1,2,4-Trichlorobenzene	625	1	5	-	-	-	-	-	-	-	-	-	-
102	Aldrin	608	0.005	-	-	-	-	-	-	-	-	-	-	-
103	α-BHC	608	0.01	-	-	-	-	-	-	-	-	-	-	-
104	β-BHC	608	0.005	-	-	-	-	-	-	-	-	-	-	-
105	γ-BHC (Lindane)	608	0.02	-	-	-	-	-	-	-	-	-	-	-
106	δ-BHC	608	0.005	-	-	-	-	-	-	-	-	-	-	-
107	Chlordane	608	0.1	-	-	-	-	-	-	-	-	-	-	-
108	4,4'-DDT	608	0.01	-	-	-	-	-	-	-	-	-	-	-
109	4,4'-DDE	608	0.05	-	-	-	-	-	-	-	-	-	-	-
110	4,4'-DDD	608	0.05	-	-	-	-	-	-	-	-	-	-	-

CTR No.	Pollutant / Parameter	Analytical Method <sup>[2]</sup>	GC	GC MS	LC	Color	FAA	GFAA	ICP	ICP MS	SPGF AA	HYD RIDE	CVAA	DCP
111	Dieldrin	608	0.01	-	-	-	-	-	-	-	-	-	-	-
112	Endosulfan (alpha)	608	0.02	-	-	-	-	-	-	-	-	-	-	-
113	Endosulfan (beta)	608	0.01	-	-	-	-	-	-	-	-	-	-	-
114	Endosulfan Sulfate	608	0.05	-	-	-	-	-	-	-	-	-	-	-
115	Endrin	608	0.01	-	-	-	-	-	-	-	-	-	-	-
116	Endrin Aldehyde	608	0.01	-	-	-	-	-	-	-	-	-	-	-
117	Heptachlor	608	0.01	-	-	-	-	-	-	-	-	-	-	-
118	Heptachlor Epoxide	608	0.01	-	-	-	-	-	-	-	-	-	-	-
119-125	PCBs: Aroclors 1016, 1221, 1232, 1242, 1248, 1254, 1260	608	0.5	-	-	-	-	-	-	-	-	-	-	-
126	Toxaphene	608	0.5	-	-	-	-	-	-	-	-	-	-	-

Footnotes:

- <sup>[1]</sup> Minimum levels are from the *State Implementation Policy*. They are the concentration of the lowest calibration standard for that technique based on a survey of contract laboratories. Laboratory techniques are defined as follows: GC = Gas Chromatography; GCMS = Gas Chromatography/Mass Spectrometry; LC = High Pressure Liquid Chromatography; Color = Colorimetric; FAA = Flame Atomic Absorption; GFAA = Graphite Furnace Atomic Absorption; ICP = Inductively Coupled Plasma; ICPMS = Inductively Coupled Plasma/Mass Spectrometry; SPGFAA = Stabilized Platform Graphite Furnace Atomic Absorption (i.e., U.S. EPA 200.9); Hydride = Gaseous Hydride Atomic Absorption; CVAA = Cold Vapor Atomic Absorption; DCP = Direct Current Plasma.
- <sup>[2]</sup> The suggested method is the U.S. EPA Method unless otherwise specified (SM = Standard Methods). The Discharger may use another U.S. EPA-approved or recognized method if that method has a level of quantification below the applicable water quality objective. Where no method is suggested, the Discharger has the discretion to use any standard method.
- <sup>[3]</sup> Analysis for total chromium may be substituted for analysis of chromium (III) and chromium (VI) if the concentration measured is below the lowest hexavalent chromium criterion (11 ug/l).
- <sup>[4]</sup> The Discharger shall use ultra-clean sampling (U.S. EPA Method 1669) and ultra-clean analytical methods (U.S. EPA Method 1631) for mercury monitoring. The minimum level for mercury is 2 ng/l (or 0.002 ug/l).
- <sup>[5]</sup> MUN = Municipal and Domestic Supply. This designation, if applicable, is in the Findings of the permit.
- <sup>[6]</sup> Determination of Asbestos Structures over 10 [micrometers] in Length in Drinking Water Using MCE Filters, U.S. EPA 600/R-94-134, June 1994.
- <sup>[7]</sup> Detected as azobenzene.